

BRENES RESIDENCE



CODE INFORMATION:

ENERGY CODE: 2015 WSEC (Ch. 51-11 WAC)

Areas of remodel to comply with requirements for additions, alterations, renovations, or repairs as outlined in WSEC Sec. R101.4.3. Per Tabele R406.2 1.5 credits required: 1.0 Credits **3d** (High Efficiency HVAC equipment-Heat pump heating) and .5 Credits **5a** (Efficient Water Heating-Low Flow fixtures)

2015 Washington State Energy Code Table R402.1.1 Prescriptive Requirements Group R Occupancy, All Climate Zones									
U- Factors				R-Values					
Glazing	Door	Clg.	Vaulted Clg.	Walls		Floor		S.O.G.	
Vert	O.H.			Abv. Grd.	Blw. Grd.				
0.30	0.50	0.20	R-49	R-38	R-10/15/21	R-21 int.	R-10/15/21	R-30	R-10
						+ TB*			2'

*R-10 cont. on ext. of wall, R-15 cont. on int. of wall, or R-21 cavity insulation + thermal break at slab. **NOTE:** Prescriptive compliance is based on the above table and any Options selected based on additional credits required for project (list Options selected for specific project)

VENTILATION & INDOOR AIR QUALITY: 2015 IMC, 2015 WSEC (Ch. 51-11 WAC)

Any new ventilation equipment to comply with WSEC Sec. R403.

-Lumos, or sim. Heat recovery ventilation per M1507.3.7, 45 CFM.

PLUMBING, MECHANICAL, & ELECTRICAL DESIGN: WAC chapter 51-56, 2015 IFC, MICC 17.13.020, Washington Cities Electrical Code

Any new heating system components to comply with WSEC Sec. 403 – Building Mechanical Systems.

Primary Heating: Gas (Existing) + Electric Heatpump Minisplit for addition

Prescriptive Heating System Sizing:

Any new heating system components shall be sized per WSEC Sec. R403.6

Fire sprinklers system shall be provided: **NFPA 13D**. Supply from SE 27th Household Fire Alarm per MFPA 72 is **required**.

SEE C.A.D. REVIEW CAO19-010 FOR CRITICAL AREA, STEEP SLOPE, REVIEW

A.D.U. (709 SF) ADDED IN LOWER FLOOR. 1 BDRM, LIVING, KITCHEN, AND BATHROOM.

SYMBOLS:

LEGEND:

EXHAUST FAN	ROOF SLOPE (RISE, RUN)
DOOR TAG	ELEVATION TAG
DOOR NUMBER (REFER TO SCHEDULE)	SLIDING DOOR/ WINDOW
WINDOW TAG	SLOPE DOWNHILL RISE:RUN
WINDOW LETTER (REFER TO SCHEDULE)	SMOKE DETECTOR/ALARM
S.D.	CARBON MONOXIDE DETECTOR/ALARM

ZONING CODE: MICC- Unified Land Development Code Title 19

Zone	R-9.6
Number of Dwellings	1 single-family
Critical Areas	Steep Slope Hazard
Site Area	9,449 sf
Max. Lot Coverage	30% (lot slope 36.3%)
Max. Bldg. Ht. Allowed	30 ft (25'-4" Proposed)
Min. Bldg. Setbacks	20 ft (front), 16ft (side), 25 ft (rear)

BUILDING CODE: 2015 International Residential Code (IRC) With Statewide and City Amendments Title 17

Standard Design Criteria per IRC Sec. R301 & Table R303.2(1)

Building Area Summary – Living (House)	
Existing	2742 sf
Removed	662 sf
Proposed	1247 sf
Total Living (3779 SF Allowed)	3327 sf

Lot Coverage Summary (see A0.01 for detail)	
Existing Lot Coverage	2876 sf
Proposed Lot Coverage	2834 sf (Complies)
Allowed Lot Coverage (30%)	2834.7 sf

Hardscape Summary (see A0.01 for detail)	
Existing Hardscape	2356 sf
Proposed Hardscape	849 sf (Complies)
Allowed Hardscape (9%)	850 sf

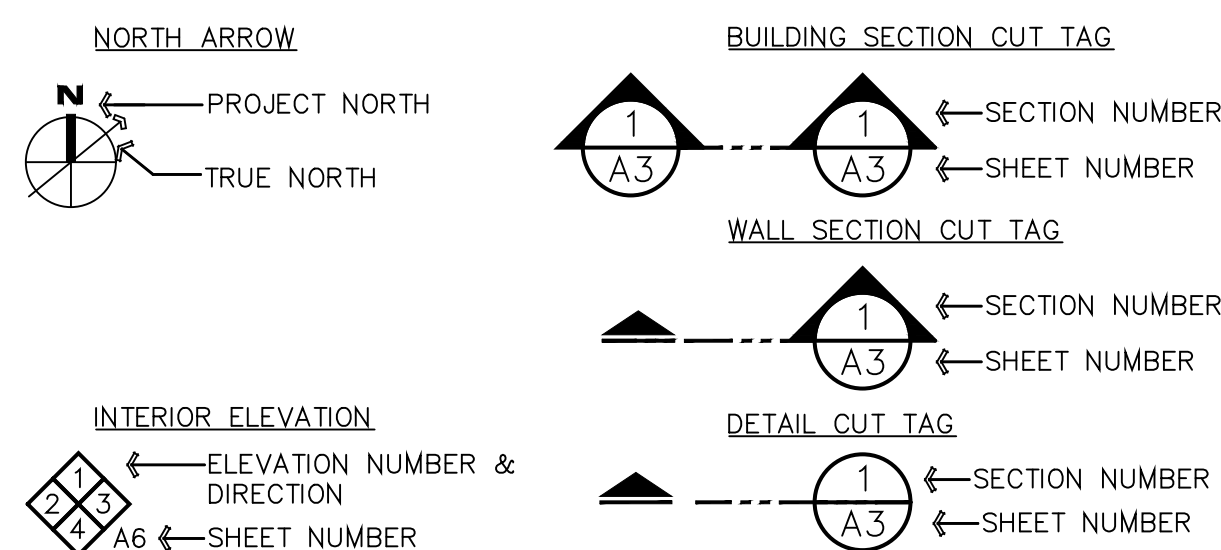

GENERAL CONDITIONS:

- These drawings are the exclusive property of the architect and may only be reproduced with the written permission of the architect.
- The contractor shall be responsible for providing all work and materials in accordance with the International Residential Code (IRC) as well as all applicable national, state, county and city codes (building, fire, health, energy, ventilation, plumbing, mechanical, electrical, etc.)
- The contractor shall be governed by all conditions as indicated in the construction documents and specifications.
- If the contractor is aware of any discrepancy between the work as shown and requirements of codes and governing agencies, they shall notify the architect and await further instruction.
- The contractor shall verify all dimensions, datums, levels, and the site conditions prior to commencing the work. The contractor shall report any discrepancies and/or omissions to the architect prior to commencing the work.
- All work shall be accomplished by qualified trade people in the specific field with required certification where applicable.
- All work shall be performed to the established trade standards using the most suitable construction methods in such trade. Aforementioned construction to include the use of applicable standard components, connectors, supports, trim, backing, blocking and/or other appurtenances.
- Set work to required levels and lines, with members plumb, true to line, cut, and fitted. Fit work to other construction; scribe and cope as needed for accurate fit. Locate furring, nailers, blocking, grounds, and similar supports to comply with requirements for attaching other construction.
- These drawings indicate general and typical details of construction. Where conditions are not specifically indicated but are of a similar character to the details shown, similar details of construction shall be used. Repetitive features not noted on the drawings shall be completely provided as if drawn in full.
- Do not scale drawings. All dimensions are from face of rough framing or face of concrete unless noted otherwise. Check details for location of items not dimensioned on the plans.
- All rough opening measurements shall be verified by the contractor.
- The contractor shall coordinate the securing of required permits and approvals with the owner.
- The contractor shall schedule on-site inspections per the building official.
- Electrical, plumbing and mechanical systems are to be bidder designed. The contractor will be responsible to produce drawings for the architect and owner to review and approve, prior to the start of installation, and to obtain all necessary permits in connection with the work.
- No deviations from or changes to the structural system shall be made without approval from the architect and engineer.
- All changes in plans and field modifications shall be approved by the building official.
- Shop drawings are required for, but not limited to, trusses, structural steel connections and fabrications. The contractor shall prepare and submit shop drawings to the architect for review and approval, and then submit to the building official. All shop drawing dimensions shall be checked and verified in the field by the contractor.
- It shall be the responsibility of the contractor to locate all existing utilities whether shown herein or not and to protect them from damage. The contractor shall bear all expense of repairs or replacement of utilities or other property damaged by operations in conjunction with the execution of the work.
- The contractor shall provide temporary facilities as required by code.
- The contractor shall provide all shoring, barricading and bracing necessary to ensure the structural stability of the project, and the health and safety of the public and all who enter the property during construction.
- The contractor shall keep areas under construction secure and clear of dirt and debris.
- The contractor shall schedule work, as much as possible, to avoid inconveniences of existing neighborhood property owners.
- The contractor shall provide all accessories required for a completely watertight installation including but not necessarily limited to: flashing, counterflashing, sealant, and caulking at all roof and floor penetrations, interlocking weather stripping at all doors and windows, water stops and other concrete inserts at below grade cold joints.
- See structural notes & details for additional concrete, steel, & rough carpentry requirements.

ABBREVIATIONS:

A.B.	Anchor bolt	JST	Joist
A.F.F.	Above finish floor	K.D.	Kiln dried
ABV	Above	L	Length
ADD	Addition	L.F.	Linear feet
ALT	Alternating	LAV	Lavatory
AWN	Awning	LOC	Location
B.F.	Bi-fold	M.O.	Masonry opening
B.P.	Bi-pass	MATL	Material
B/I	Built-in	MAX	Maximum
B/U	Built-up	MECH	Mechanical
BLDG	Building	MFR	Manufacturer
BLKG	Blocking	MIN	Minimum
BLW	Below	MTL	Metal
BM	Beam	(N)	New
BRD	Board	N.A.	Not applicable
BRG	Bearing	N.I.C.	Not in contract
BSBL	Building Setback Line	N.T.S.	Not to scale
C.F.	Cubic feet	O/	Over
C.J.	Control Joint	O.C.	On center
C.L.	Center line	O.D.	Outside diameter
CALC	Calculation	O.H.	Overhang
CANT	Cantilever	O.H.D.	Overhead door
CAS	Casement	ODWH	On-demand water heater
CLG	Ceiling	OPP	Opposite
CLR	Clear	OPTL	Optional
COL	Column	PLAM	Parallam
CONC	Concrete	P.T.	Pressure treated
CONST	Construction	PD	Plumbing drop
CONT	Continuous	PERP	Perpendicular
COORD	Coordinate	PKT	Pocket
CSMT	Casement	PL	Plate
D	Depth	PLMG	Plumbing
D.H.	Double hung	PLYWD	Plywood
DBL	Double	PSF	Per square foot
DEMO	Demolish	R	Riser
DIA	Diameter	R.O.	Rough opening
DIM	Dimension	R.S.	Rough sawn
DN	Down	R-VALUE	Thermal resistance
DR	Door	REF	Refrigerator
DS	Down spout	REQD	Required
DTL	Detail	REV	Revision
DWG	Drawing	RFRTR	Rafter
E.J.	Expansion joint	S	Sink
E.W.	Each way	S&P	Shelf and pole
EA	Each	S.C.	Solid core wood
EL	Elevation	S.D.	Smoke detector
E.P.D.M.	Ethylene Propylene Diene Monomer	S.F.	Square feet
EQ	Equal	S.G.	Safety glass
EQUIP	Equipment	S.H.	Single hung
ESMT	Easement	S.O.G.	Slab on grade
EXG	Existing	S.W.	Shear wall
EXP	Exposure	SHT	Sheet
EXT	Exterior	SHTG	Sheeting
F	Fixed	SIM	Similar
F.D.	Floor Drain	SLDR	Slider
F.F.	Finish Floor	SPEC	Specification
F.P.	Fireplace	STD	Standard
F.V.	Field verify	STL	Steel
FDN	Foundation	STRUCT	Structural
FIN	Finish	T	Tread
FL	Flush	T&G	Tongue and groove
FLR	Floor	T.O.B.	Top of beam
FRDR	French door	T.O.S.	Top of slab
FTG	Footing	T.O.W.	Top of wall
F.S.C.	Forest Stewardship Council	TEMP	Temporary
G.F.I.	Ground fault interrupt	THK	Thick
G.W.B.	Gypsum wall board	TYP	Typical
GA	Gauge	U.N.O.	Unless noted otherwise
GALV	Galvanized	UNHTD	Unheated
GL	Glass, glazing	V.B.	Vapor barrier
GLB	Glulam beam	V.T.O.	Vent to outside
H, HT	Height	V.I.F.	Verify in field
H.B.	Hose bibb	VERT	Vertical
H.C.	Hollow core wood	W	Width
HDR	Header	W/	With
HDWD	Hardwood	W/D	Washer/Dryer
HORZ	Horizontal	W/O	Without
HWT	Hot water tank	W.C.	Water closet
I.D.	Inside diameter	WD	Wood
INSUL	Insulation	W.I.C.	Walk in closet
INT	Interior	WIN	Window
ICF	Insulated concrete form	WP	Waterproof
		X	by

OWNER:
CHRIS AND JEN BRENES
2675 74TH AVE SE
MERCER ISLAND, WA 98040
PH: 619.957.5849

PROJECT TEAM:

Architect:
 Living Shelter Architects
 PO Box 1477
 Issaquah, WA 98027
 Principal: Terry Phelan
 Contact: Roy McGarran
 P: 425-427-8643
 E: roy@livingshelter.com

Structural Engineer:
 Swenson Say Faget
 2124 Third Ave, Suite 100
 Seattle, WA 98121
 Contact: Karl Rosman
 P: (206) 443-6212
 E: info@ssfengineers.com

PROJECT SUMMARY:

-Addition/Renovation to a single-family home. Replace carport with garage and rooms above, replace decks, remove north rocky.
 -Primary Heat Source: Gas + Electric Heatpump
 -Lower level converted to ADU
 -Work will be completed under a general construction contract.

DRAWING INDEX:

G0.00	Cover Sheet & Project Information
G0.01	General Notes
G0.02	Schedules
G0.03	Lot Coverage
A0.00	Site Plan
A0.01	Lot Coverage/ Hardscape
A0.02	Survey 1
A0.03	Survey 2
A0.06	Concept Grading Plan
A1.01	Lower Floor Deconstruction Plan
A1.02	Upper Floor Deconstruction Plan
A1.03	Roof Deconstruction Plan
A1.11	Proposed Lower Floor Plan
A1.12	Proposed Upper Floor Plan
A1.13	Proposed Roof Plan
A2.01	Existing Exterior Elevations
A2.01	Existing Exterior Elevations
A2.11	Proposed Exterior Elevations
A2.12	Proposed Exterior Elevations
A3.01	Building Sections
A3.02	Building Sections
A3.03	Wall Section
A5.01	Details
A5.02	Details
A5.03	Water Proofing Details
A8.1	Interior Elevations
L0.01	Landscape Plan

Structural

S1.1	General Structural Notes
S1.2	General Structural Notes
S2.1	Main Floor Framing/Foundation Plan
S2.2	Upper Floor Framing Plan
S2.3	Roof Framing Plan
S3.1	Foundation Details
S3.2	Foundation Details
S4.1	Typical Wood Framing Details
S4.2	Wood Framing Details

VICINITY MAP & PROJECT ADDRESS:

2675 74th Ave SE
 Mercer Island, WA, 98040

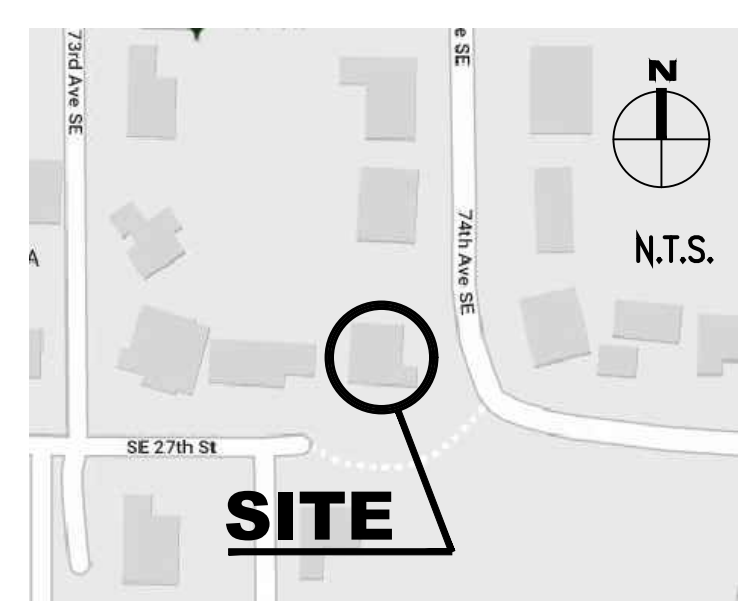

LSA

LIVING SHELTER ARCHITECTS PLLC

472-A FRONT ST. N
 ISSAQUAH, WA 98027
 (425) 427-8643

© 2018 LSA. All rights reserved.

file **1644**

project name

BRENES REMODEL

project address
 2675 74th Ave SE
 Mercer Island, WA 98040

owner
CHRIS & JEN BRENES
 619.957.5849
 jenniferbrenes@comcast.net

project manager
ROY MCGARRAH
 living shelter architects
 425.427.8643
 roy@livingshelter.com

survey
C & C SURVEYING, LLC
 425.673.7502
 ccsurveyllc@gmail.com

structural engineer
SWENSON SAY FAGET
 206.443.6212
 info@ssfengineers.com

geotechnical engineer
EARTH SOLUTIONS NW
 425.284.3300
 kevenh@esnw.com

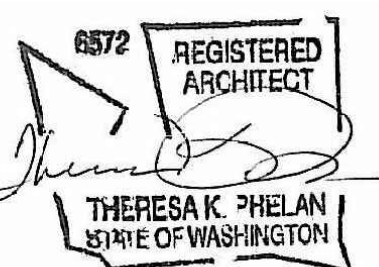

revisions

REV: 2/13/20

date **16 JAN 2020**

sheet title

COVER

sheet number

G0.00

II. CONSTRUCTION REQUIREMENTS

Coordinate with Structural Specifications sheet S1.1.

3100 CAST-IN-PLACE CONCRETE

1.1 GENERAL

A. SUMMARY

1. Comply with "Part II, Sustainable Materials and Methods".

B. QUALITY ASSURANCE

1. Comply with ACI 301, "Specification for Structural Concrete."

2.1 MATERIALS

- A. Formwork: Furnish formwork and form accessories according to ACI 301.
B. Steel Reinforcing Bars: ASTM A, Grade 40, deformed.
C. Concrete Materials:
1. Portland Cement: ASTM C 150, Type I or II.
 2. Normal-Weight Aggregate: ASTM C 33, uniformly graded.
 3. Water: Complying with ASTM C 94.
 4. Fly Ash: AASHTO M-295, Class C or F.

2.2 CONCRETE MIXES

- A. Comply with ACI 301 requirements for normal-weight concrete as follows:
1. Compressive Strength 28 Days (56 day preferred): 3000 psi.
 2. Slump: 5 inches or less.
 3. Limit percentage, by weight, of cementitious materials other than Portland cement in concrete as follows:
Footings: 25% +/- 5%
All others: 18% +/- 2%

3.1 CONCRETE PLACEMENT

- A. Comply with recommendations in ACI 304R for measuring, mixing, transporting, and placing concrete.
B. Foundation walls shall be constructed per the provisions of Sec. R404.1.
C. The floor diaphragm shall be completed before backfilling, or the foundation wall sufficiently braced to prevent damage. The maximum unbalanced backfill height shall be 30", unless otherwise designed and approved.
D. Vertical steel shall be placed within the inside half of the wall and not closer than 3/4" clear from the inside face of the wall.
E. There shall be a minimum of (2) anchor bolts per foundation sill plate with one bolt located within 12" of each end of each foundation sill plate.
F. Fasteners in contact with pressure treated lumber shall be of either stainless steel or steel with hot dipped galvanized steel coating of G90 or greater.

5100 STRUCTURAL & MISC. STEEL

1.1 GENERAL

A. SUMMARY

1. Comply with "Part II, Sustainable Materials and Methods".

B. QUALITY ASSURANCE

1. Comply with applicable provisions in AISC's "Specification for Structural Steel Buildings--Allowable Stress Design and Plastic Design."
2. Welding: Qualify procedures & personnel according to AWS D1.1, "Structural Welding Code"

2.1 MATERIALS

- A. Structural-Steel Shapes, Plates, and Bars: ASTM A 36, carbon steel.
B. Cold-Formed Structural-Steel Tubing: ASTM A 500, Grade B.

2.2 FABRICATION

- A. Fabricate and assemble structural steel in shop to greatest extent possible.
B. Fabricate structural steel according to AISC specifications referenced in this Section and in the Shop Drawings.

6100 ROUGH CARPENTRY

1.1 GENERAL

A. SUMMARY

1. See "Part II, Sustainable Materials and Methods", for lumber certification, low V.O.C. requirements.

2.1 DIMENSION LUMBER

- A. General: Of grades indicated according to the American Lumber Standards Committee National Grading Rule provisions of the grading agency indicated.
B. Non-Load-Bearing Interior Partitions: Construction, Stud, or No. 2 grade, WCLB.
C. Framing Other Than Non-Load-Bearing Partitions: K.D. No. 2 grade Hem-fir; WCLB.
D. Exposed Framing: Hand select material for uniformity of appearance and freedom from characteristics that would impair finish appearance.
1. Species and Grade: As indicated above for load-bearing construction of same type.

2.2 TIMBER AND MISCELLANEOUS LUMBER

- A. For timbers of 5-inch nominal size and thicker, provide material complying with the following:
1. Species and Grade: Douglas fir, No. 1 grade; WCLB.
- B. Provide miscellaneous lumber for support or attachment of other construction.

2.3 ENGINEERED WOOD PRODUCTS

- A. Laminated-Veneer Lumber: Composite of wood veneers with grain primarily parallel to member lengths, manufactured with exterior-type adhesive complying with ASTM D 2559. Allowable design values determined according to ASTM D 5456. Exposed members shall be Architectural grade.
B. Wood I-Joists: Prefabricated units complying with APA PRI-400; depths and performance ratings not less than those indicated in the plans.
C. Rim Boards: Performance-rated product complying with APA PRR-401.

2.4 SHEATHING

- A. Plywood Wall & Roof Sheathing: APA Rated Exposure 1, or Exterior sheathing, nailed.

2.5 SUBFLOOR

- A. Plywood Subflooring: APA Rated Exposure 1, or Exterior tongue & groove sheathing, glued and nailed.

2.6 WOOD-PRESERVATIVE-TREATED MATERIALS

- A. Preservative Treatment by Pressure Process: AWPA C2 (lumber) & AWPA (plywood).

2.7 MISCELLANEOUS MATERIAL

A. Fasteners:

1. Where rough carpentry is exposed to weather, in ground contact, or in area of high relative humidity, provide fasteners w/ hot-dip zinc coating complying w/ ASTM A 153/A.
2. Power-Driven Fasteners: CABO NER-272.
3. Bolts: Steel bolts complying with ASTM A 307, Grade A; with ASTM A 563 hex nuts and, where indicated, flat washers.

- B. Metal Framing Anchors: Made from hot-dip, zinc-coated steel sheet complying with ASTM A 653/A, G90 coating designation.

- C. Building Paper: Asphalt-saturated organic felt complying with ASTM D 226, Type I (No. 15 asphalt felt), unperforated.

1. All wood exposed to plaster to be covered with building paper.

3.1 INSTALLATION

- A. Securely attach rough carpentry work to substrate by anchoring and fastening as indicated, complying with the IRC Sec. R602, & Table R602.3(1)
B. Framing Standard: Comply with AFPA's "Manual for Wood Frame Construction," u.n.o.
C. Framing with Engineered Wood Products: Install engineered wood products to comply with manufacturer's written instructions.

8100 SUSTAINABLE MATERIALS AND METHODS

1.1 MATERIALS

- A. Use low toxic/low volatile organic compound (VOC) materials where possible throughout project, especially on interior surfaces.
1. Examples include paints & finishes, water-based products, solvent-free sealers, grouts, mortars, caulks, and adhesives.
- B. Limit pressure treated (P.T.) components: no wood treated with chromated copper arsenate (CCA) or ammoniacal copper arsenate (ACA) may be used on this job. Wood treated with alkaline/copper/quatarnary (ACQ) is acceptable.
C. Provide F.S.C. (Forest Stewardship Council) certified lumber to greatest extent possible.
D. Steel shall be certified min. 80% recycled-content.
E. Provide fly ash in concrete mix.
F. Avoid PVC throughout project to the greatest extent possible.
G. Use 75% minimum Energy Star light fixtures.

2.1 METHODS

- A. Submit jobsite recycling plan prior to start of construction.

1. Achieve a minimum recycling rate of 70% of waste by weight.
2. Follow recycling plan once posted on jobsite.
3. All sub/contractors to comply with recycling plan & waste reduction efforts.

Example of materials to recycle: cardboard, metal scrap, wood scrap, broken pallets, packaging, concrete rubble, rock, brick, land clearing/yard waste, soil, other construction materials and surplus as appropriate.

- B. Allow proper ventilation and curing time for strong construction.
C. Sub/contractor to notify owner prior to use of compounds/materials with strong odors.
D. Seal at doors, windows, plumbing & electrical penetrations against moisture and air leaks.



LSA

LIVING SHELTER ARCHITECTS PLLC

472-A FRONT ST. N
ISSAQUAH, WA 98027
(425) 427-8643

© 2018 LSA. All rights reserved.

file

1644

project name

BRENES REMODEL

project address
2675 74th Ave SE
Mercer Island, WA 98040

owner
CHRIS & JEN BRENES
619.957.5849
jenniferbrenes@comcast.net

project manager
ROY MCGARRAH
living shelter architects
425.427.8643
roy@livingshelter.com

survey
C & C SURVEYING, LLC
425.673.7502
ccsurveyllc@gmail.com

structural engineer
SWENSON SAY FAGET
206.443.6212
info@ssfengineers.com

geotechnical engineer
EARTH SOLUTIONS NW
425.284.3300
kevenh@esnw.com

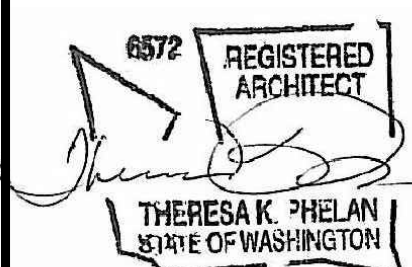

revisions

1 REV: 2/13/20

date
16 JAN 2020

sheet title

GENERAL NOTES

sheet number

G0.01



LSA

LIVING SHELTER ARCHITECTS PLLC

472-A FRONT ST. N
ISSAQUAH, WA 98027
(425) 427-8643

© 2018 LSA. All rights reserved.

file
1644
project name

BRENES REMODEL

project address
2675 74th Ave SE
Mercer Island, WA 98040

owner
CHRIS & JEN BRENES
619.957.5849
jenniferbrenes@comcast.net

project manager
ROY MCGARRAH
living shelter architects
425.427.8643
roy@livingshelter.com

survey
C & C SURVEYING, LLC
425.673.7502
ccsurveyllc@gmail.com

structural engineer
SWENSON SAY FAGET
206.443.6212
info@ssfengineers.com

geotechnical engineer
EARTH SOLUTIONS NW
425.284.3300
kevenh@esnw.com

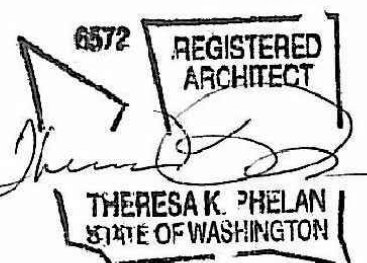

revisions
1 REV: 2/13/20

date
16 JAN 2020

sheet title

SCHEDULES

sheet number

GO.02

DOOR SCHEDULE								
	MARK	QTY	WIDTH	HEIGHT	MFR	TYPE	HARDWARE	NOTES
EXT.	1	1	3'-0"	7'-0"	TBD	SWING	TBD	SAFETY GLASS
	2	2	3'-0"	6'-8"	TBD	SWING	TBD	SAFETY GLASS
	3	1	16'-0"	7'-0"	TBD	GARAGE	TBD	
	4	1	9'-0"	6'-8"	TBD	XOX SWING	TBD	SAFETY GLASS
	12	1	9'-0"	6'-8"	TBD	XOX SLIDE	TBD	SAFETY GLASS
	13	1	4'-8"	7'-0"	TBD	FRENCH	TBD	SAFETY GLASS
INT.	5	1	2'-8"	6'-8"	TBD	SWING	TBD	
	6	1	3'-0"	6'-8"	TBD	SWING	TBD	
	7	1	3'-6"	6'-8"	TBD	BI-FOLD	TBD	
	8	5	2'-6"	6'-8"	TBD	SWING	TBD	
	9	1	5'-0"	6'-8"	TBD	BI-FOLD	TBD	
	10	1	2'-6"	6'-8"	TBD	POCKET	TBD	
	11	1	2'-4"	6'-8"	TBD	POCKET	TBD	
14	2	2'-6"	6'-8"	TBD	SWING	TBD		

NOTES:

- Contractor to verify hardware
- Contractor to verify rough opening per mfr.
- Contractor to verify owner preference for (1) door or (2).

1

WINDOW SCHEDULE												
MARK	QTY	WIDTH	HEIGHT	MFR	SERIES	TYPE	ORIENT	U-VALUE	SHGC	VT	HARDWARE	REMARKS
A	4	2'-8"	2'-8"	TBD	TBD	CASEMENT		0.3	TBD	TBD	PER MFR.	
B	1	2'-0"	7'-0"	TBD	TBD	FIXED		0.3	TBD	TBD	PER MFR.	SAFETY GLASS
C	3	2'-4"	3'-6"	TBD	TBD	CASEMENT		0.3	TBD	TBD	PER MFR.	SAFETY GLASS
D	1	2'-4"	2'-0"	TBD	TBD	FIXED		0.3	TBD	TBD	PER MFR.	
E	1	2'-4"	5'-0"	TBD	TBD	CASEMENT		0.3	TBD	TBD	PER MFR.	
F	1	4'-0"	2'-0"	TBD	TBD	FIXED		0.3	TBD	TBD	PER MFR.	
G	1	4'-0"	5'-0"	TBD	TBD	FIXED		0.3	TBD	TBD	PER MFR.	
H	2	4'-0"	3'-6"	TBD	TBD	FIXED		0.3	TBD	TBD	PER MFR.	SAFETY GLASS, ON/OFF ELECT.
I	1	4'-0"	4'-6"	TBD	TBD	FIXED		0.3	TBD	TBD	PER MFR.	
J	1	2'-8"	4'-6"	TBD	TBD	CASEMENT		0.3	TBD	TBD	PER MFR.	
K	1	4'-6"	3'-6"	TBD	TBD	SLIDER		0.4	TBD	TBD	PER MFR.	
L	1	2'-8"	5'-0"	TBD	TBD	CASEMENT		0.5	TBD	TBD	PER MFR.	
M	1	3'-4"	5'-0"	TBD	TBD	CASEMENT		0.3	TBD	TBD	PER MFR.	SAFETY GLASS
N	1	3'-4"	1'-0"	TBD	TBD	FIXED		0.3	TBD	TBD	PER MFR.	
O	1	4'-8"	1'-0"	TBD	TBD	FIXED		0.3	TBD	TBD	PER MFR.	
P	2	2'-4"	3'-2"	TBD	TBD	CASEMENT		0.3	TBD	TBD	PER MFR.	
Q	1	2'-4"	5'-10"	TBD	TBD	CASEMENT		0.3	TBD	TBD	PER MFR.	REPLACE EXIST. WITH CASEMENT. SAFETY GLASS, EGRESS
R	1	2'-0"	8'-10"	TBD	TBD	FIXED		0.3	TBD	TBD	PER MFR.	REPLACE EXIST. W/ 2'-0" HEIGHT. GANGED, HOLD TO E. HEAD

NOTES:

- See elevations/plans for operation and grids, and location of egress and safety glass.
- See plan notes and main floor plan for head heights.
- Wall thicknesses vary, F.V. prior to ordering.
- Low-e coating
- Locate windows between countertop/backsplash and upper cabinets. Coordinate w/ millwork and owner.
- Thermostat-controlled, automatic venting skylight

VENTILATION SCHEDULE	
See 2015 WSEC - Table 406.2, Option x Req's	
SYMBOL	MIN. REQUIRED CFM
	See IRC Table 1507.3.3(1)
	100
	50

NOTES:

- 1= Whole house fan. Integrate w/ forced air system and provide auto-timer w/ manual override.
- Use 100 CFM (min.) fan @ kitchen(s)
- Use 50 CFM (min.) fan @ all other locations
- All fans vent to outside
- All other WSEC req's must be met

ROOFS ARE NON-VENTED

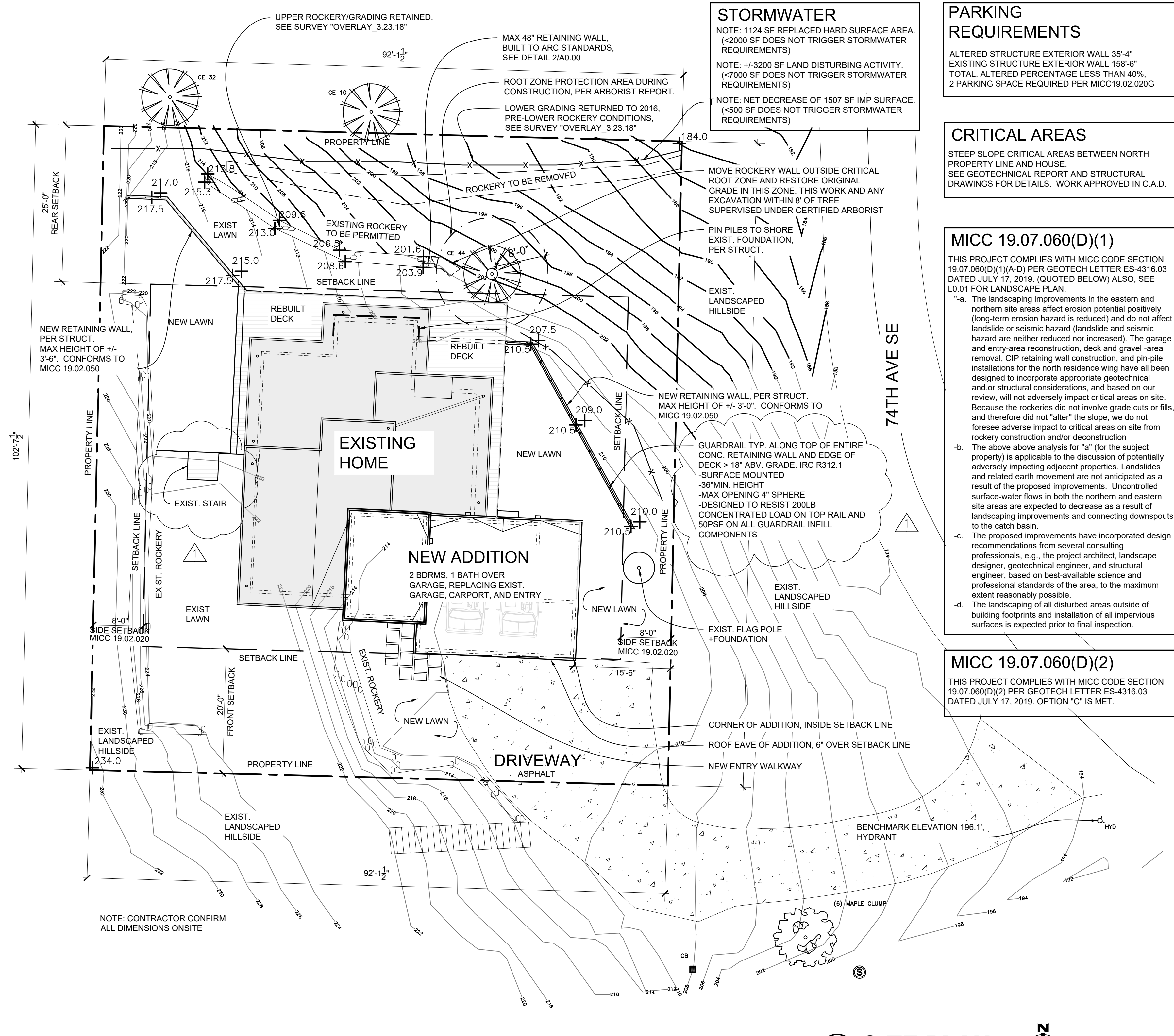

THIS SITE DRAWING SHOWS CONTOURS ADJUSTED FOR THE REMOVAL OF THE LOWER ROCKERY ON THE NORTH SLOPE OF THE PROPERTY, PER 1/A0.03, WHILE RETAINING THE UPPER ROCKERY. IT ALSO SHOWS THE REDUCED SCOPE RE-BUILD OF THE DECKS AROUND THE W, N, AND E OF THE HOUSE, INCLUDING TWO NEW RETAINING WALLS TO CREATE UPPER AND LOWER LAWNS. FINALLY, IT SHOWS THE ADDITION TO THE SE OF THE HOUSE REPLACING THE EXISTING CARPORT/GARAGE/ENTRY WITH A NEW ENTRY/2 CAR GARAGE/ WITH 2 BEDROOMS 1 BATH ABOVE.

1 SITE PLAN
 1"=10'-0"

SITE PLAN NOTES

- Submit jobsite recycling plan prior to start of construction.
 - Achieve a minimum recycling rate of 70% of waste by weight.
 - Follow recycling plan once posted on jobsite.
- All sub/contractors to comply with recycling plan & waste reduction efforts.

Example of materials to recycle: cardboard, metal scrap, wood scrap, broken pallets, packaging, concrete rubble, rock, brick, land clearing/ yard waste, soil, other construction materials and surplus as appropriate.
- Use pervious materials for minimum 33% total area for drives, walks, & patios.
- Grade to drain away from buildings, typical.
- Amend disturbed soil to a depth of 8-10 inches to restore soil environmental functions.
- Perimeter drainage to be installed as follows:
 - Perf. Pipe surrounded and set in a min. 2" depth bed w/ a min. 3/4" crushed stone free of smaller particles (to prevent clogging).
 - Perf. Pipe & crushed stone shall be surrounded by a filter membrane to prevent adjacent soil from washing into & clogging the drain system.
 - Minimum 1/4" per foot slope and connected to daylight.
- Roof and footing drains are to be connected separately to the storm drain system unless otherwise allowed.

LOT DESCRIPTION

Site Address	2675 74 TH AVE SE Mercer Island, WA 98040
Parcel #	5315100392
Legal Description	MC GILVRAS ISLAND ADD E 92.15 FT OG S 102.65 FT
Zoning	R-9.6

LOT COVERAGE

Lot Size = 9449 sf	1474 sf
Existing Roof	662 sf
Existing Garage + Carport	740 sf
Existing Driveway	-662 sf
Demo Existing Garage + Carport	-52 sf
Demo section of exist. Driveway	672 sf
New Roof	2834 sf
Total	30.0 %
Lot Coverage	30.0 %
Max. Allowed	30.0 %

HARDSCAPE

Lot Size = 9449 sf	2356 sf
Existing	-1941 sf
Demo Existing Decks + Rockery	434 sf
New Reduced Deck + Site walls	849 sf
Total Proposed	850 sf
Max. Allowed	850 sf

SURVEY PREPARED BY
 C & C Surveying LLC
 4509 243RD PL AW
 Mountlake Terrace, WA 98043
 425.673.7502
 ccsurveyllc@gmail.com

SEE C.A.D. REVIEW CAO19-010 FOR CRITICAL AREA, STEEP SLOPE, REVIEW

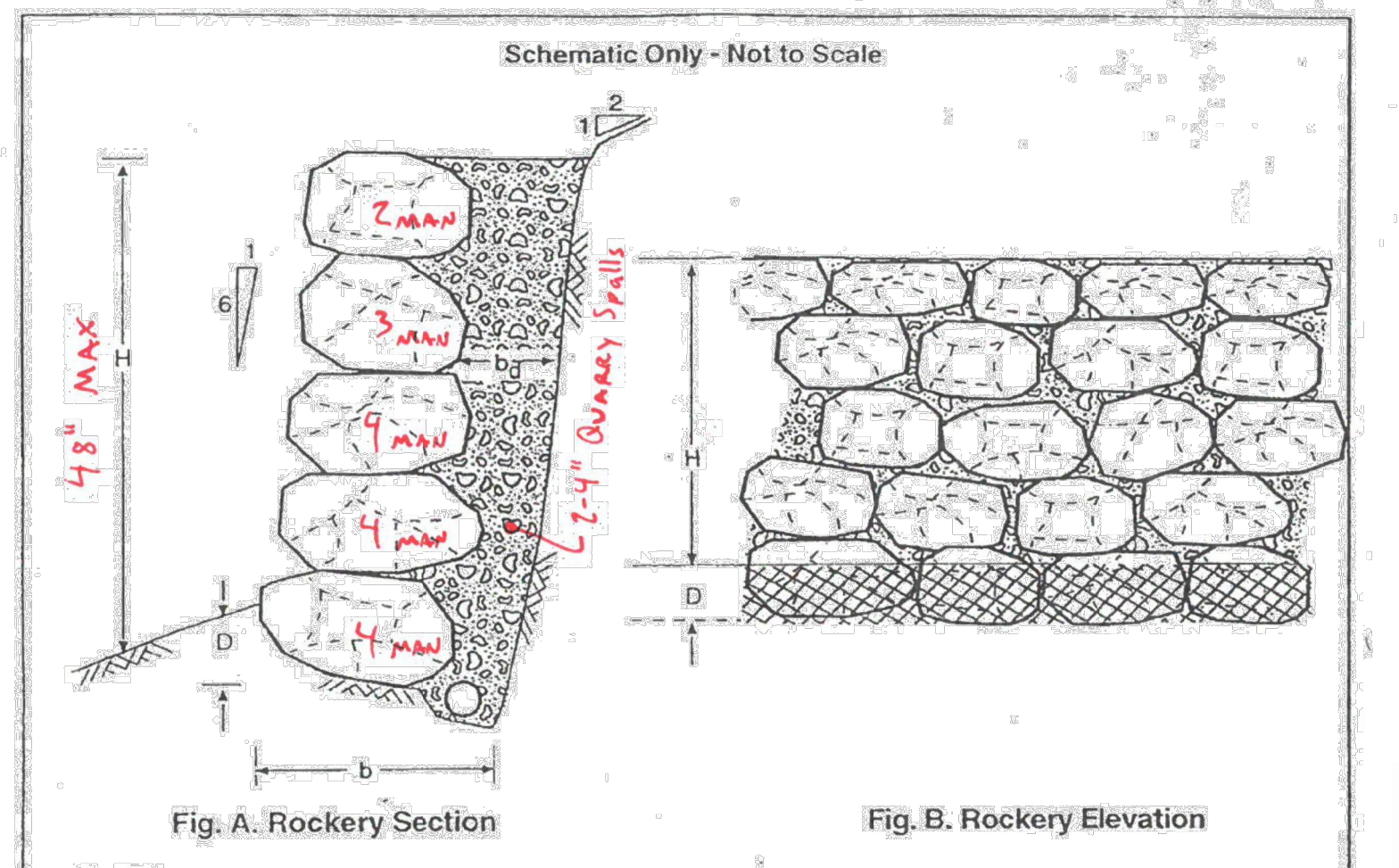

NOTES

- Rockery construction is a craft and depends largely on the skill and experience of the builder.
- A rockery is a protective system which helps retard the weathering and erosion process on an exposed soil face.
- While by its nature (mass, size and shape of the rocks) it will provide some degree of retention, it is not a designed or engineered system in the sense a reinforced concrete retaining wall would be considered designed or engineered.
- The degree of retention achieved is dependent on the size of the rock used; that is, the mass or weight, and the height of the wall being constructed. The larger the rock, the more competent the rockery should be.
- Rockeries should be considered maintenance items that will require inspection and repair. They should be located so that they can be reached by a contractor if repairs become necessary.
- Maximum inclination of the slopes above and behind rockeries should be 2:1 (Horizontal/Vertical).
- Minimum thickness of rock filter layer b = 12 inches.
- Minimum embedment D = 12 inches undisturbed native soil or compacted fill placed in accordance with report recommendations.
- Maximum rockery height H = 6 feet.
- Rockeries greater than 8 feet in height to be installed under periodic or full time observation of the geotechnical engineer.
- Rocks should be placed to gradually decrease in size with increasing wall height in accordance with geotechnical engineers recommendations.
- Minimum width of keyway excavation, b, should be equal to the thickness of the basal rock (as determined by the geotechnical engineer) plus b₁.

The long dimension of the rocks should extend back towards the cut or fill face to provide maximum stability. Rocks should not be stacked like shoe boxes. They should be placed to avoid continuous joint planes in vertical or lateral directions whenever possible. Whenever possible each rock should bear on two or more rocks below it, with good flat-to-flat contact.

All rockeries over 4 feet in height should be constructed on basis of wall mass, not square footage of face, and should be subject to engineering "design" by geotechnical engineer.

Size	Approximate Weight - lbs.	Approximate Diameter
1 Man	50 - 200	12 - 18"
2 Man	200 - 700	18 - 28"
3 Man	700 - 2000	28 - 36"
4 Man	2000 - 4000	36 - 48"
5 Man	4000 - 8000	48 - 54"
6 Man	8000 - 8000	54 - 60"

Reference: Local quarry weight study using average weights of no less than six rocks of each man size conducted in January, 1988.

LEGEND

- Drainage materials to consist of clean angular 4 to 2 inch spalls, or other material approved by the geotechnical engineer.
- Surface soil; may consist of impervious soil or a fine free-draining granular material.
- Undisturbed firm Native soil.
- Drain pipe: 4-inch minimum diameter, perforated or slotted, rigid, smooth-walled, plastic ADS pipe laid with a positive gradient to discharge under control well away from the wall.

TYPICAL ROCKERY DETAIL
 NATIVE CUT, ANY HEIGHT OVER 4 FEET

ARC
 REGISTERED ARCHITECT
 THERESA K. PHELAN
 STATE OF WASHINGTON

2 AS-BUILT ROCKERY DETAIL
 NTS

"UPPER AND LOWER ROCKERIES" ON NORTH SLOPE OF PROPERTY BUILT BY B&R ENTERPRISES LLC (FORMERLY "BY DESIGN ROCKERIES") IN 2017



LIVING SHELTER ARCHITECTS PLLC

472-A FRONT ST. N
 ISSAQUAH, WA 98027
 (425) 427-8643

file 1644

project name
BRENES REMODEL

project address
 2675 74th Ave SE
 Mercer Island, WA 98040

owner
 CHRIS & JEN BRENES
 619.957.5849
 jenniferbrenes@comcast.net

project manager
 ROY MCGARRAH
 living shelter architects
 425.427.8643
 roy@livingshelter.com

survey
 C & C SURVEYING, LLC
 425.673.7502
 ccsurveyllc@gmail.com

structural engineer
 SWENSON SAY FAGET
 206.443.6212
 info@ssfengineers.com

geotechnical engineer
 EARTH SOLUTIONS NW
 425.284.3300
 kevenh@esnw.com

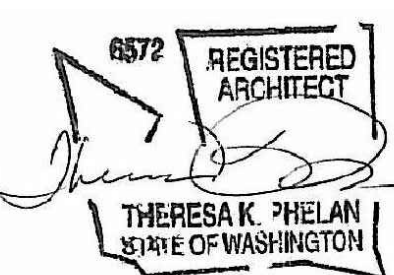

revisions
 1 REV: 2/13/20

date
 16 JAN 2020

sheet title
SITE PLAN

sheet number

A0.00

HARDSCAPE-EXISTING	
TYPE	QTY (SF)
DECKS	1304
ROCKERIES 1	208
2	36
3	100
GRAVEL AREA 1	269
2	175
STEEP SLOPE ROCKERIES 1	193
2	71
TOTAL	2356

LOT COVERAGE-EXISTING	
TYPE	QTY (SF)
HOUSE	1474
GARAGE/CARPORT	662
DRIVEWAY	740
TOTAL	2876

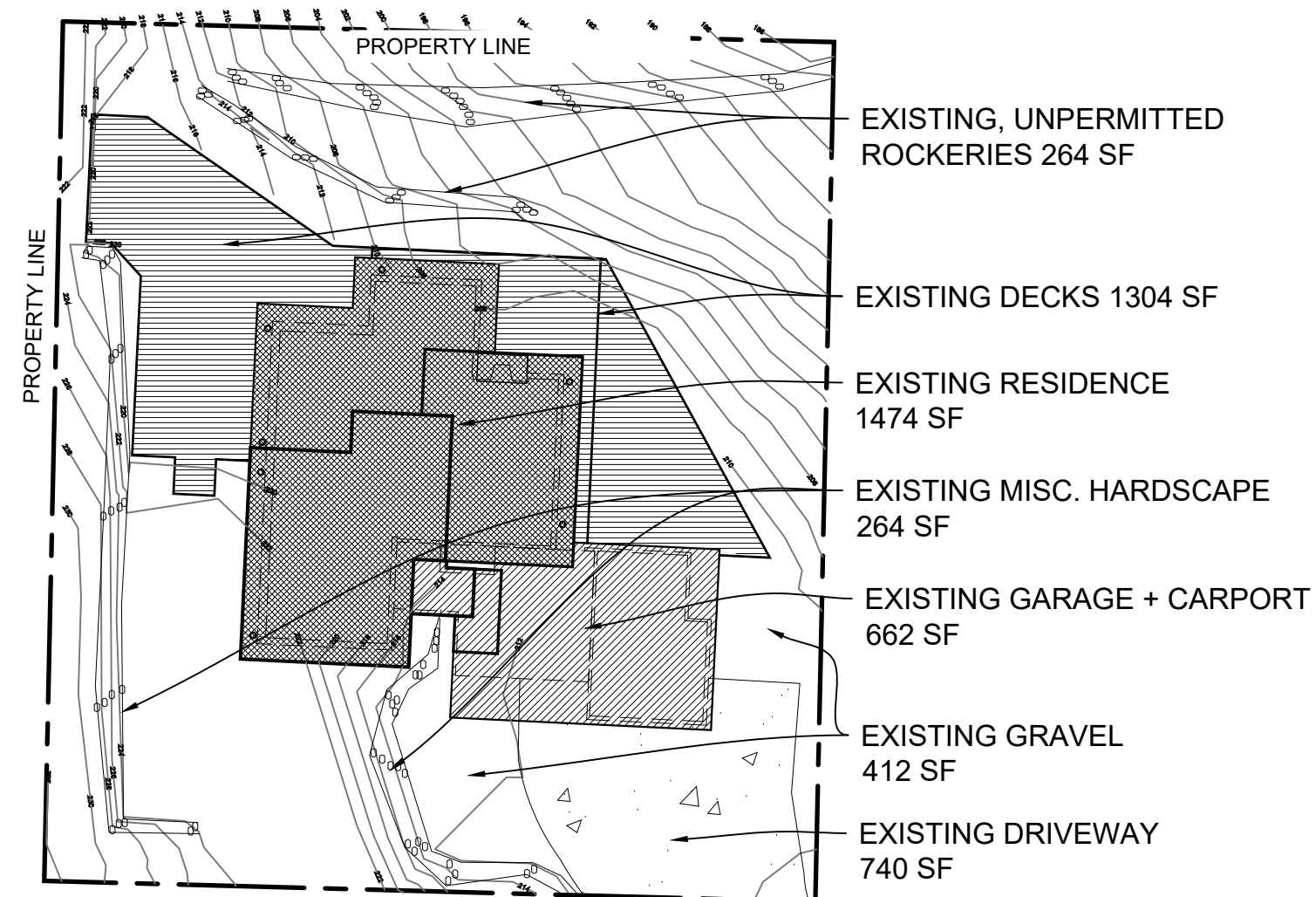

EXISTING-LOT COVERAGE 2876 SF
 ALLOWED-LOT COVERAGE 2834.7 SF
 EXISTING-HARDSCAPE 2356 SF
 ALLOWED-HARDSCAPE 850 SF

1 EXISTING LOT CONDITIONS
 1"=20'

HARDSCAPE-DEMO	
TYPE	QTY (SF)
DECKS	1304
GRAVEL	269
STEEP SLOPE ROCKERIES	193
TOTAL	1941

LOT COVERAGE-DEMO	
TYPE	QTY (SF)
DRIVEWAY	52
GARAGE/CARPORT	662
TOTAL	714

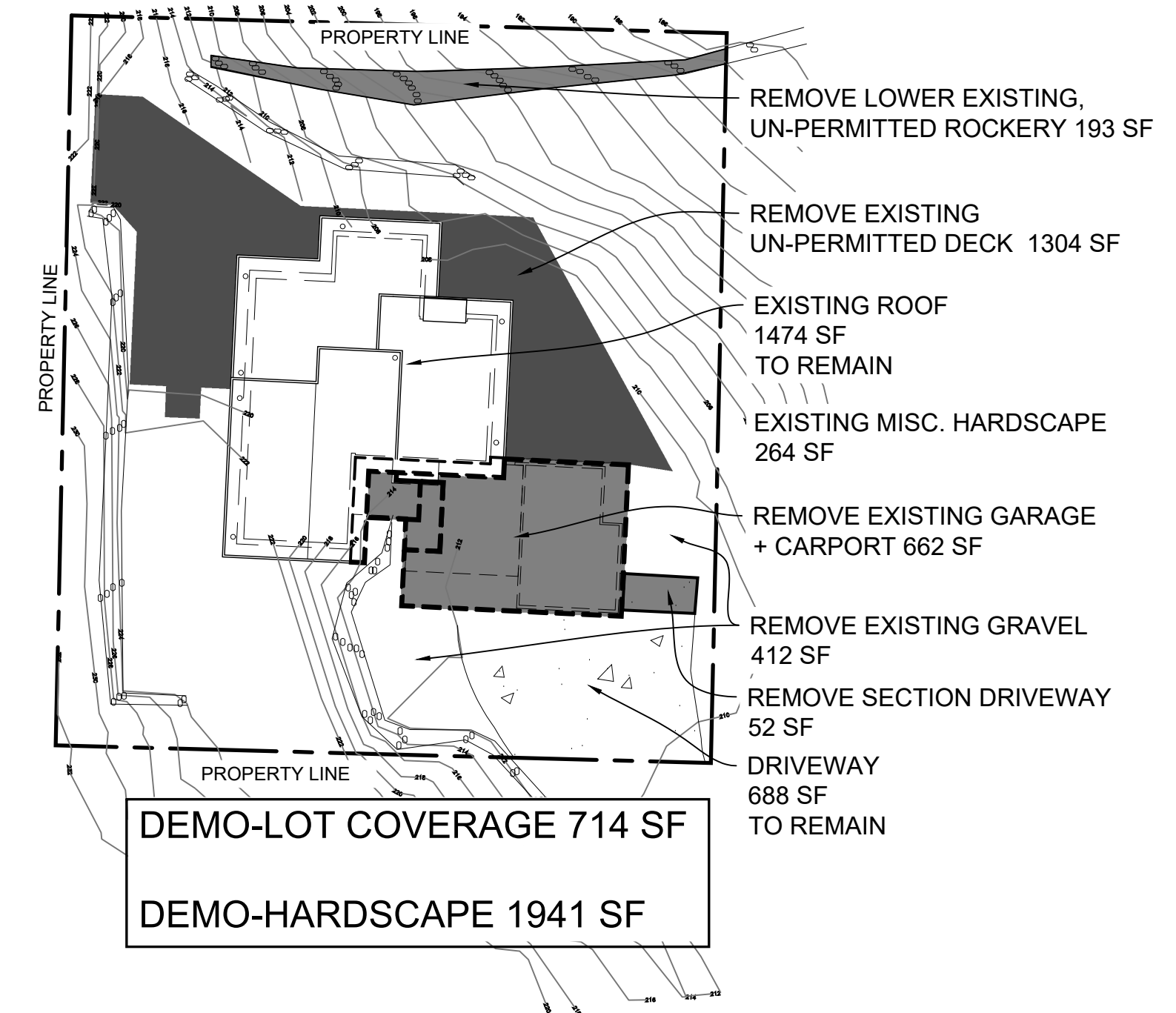

DEMO-LOT COVERAGE 714 SF
 DEMO-HARDSCAPE 1941 SF

2 DEMO. LOT CONDITIONS
 1"=20'

NOTE: CONCEPT GRADING PLAN ADDED AS SHEET A0.06

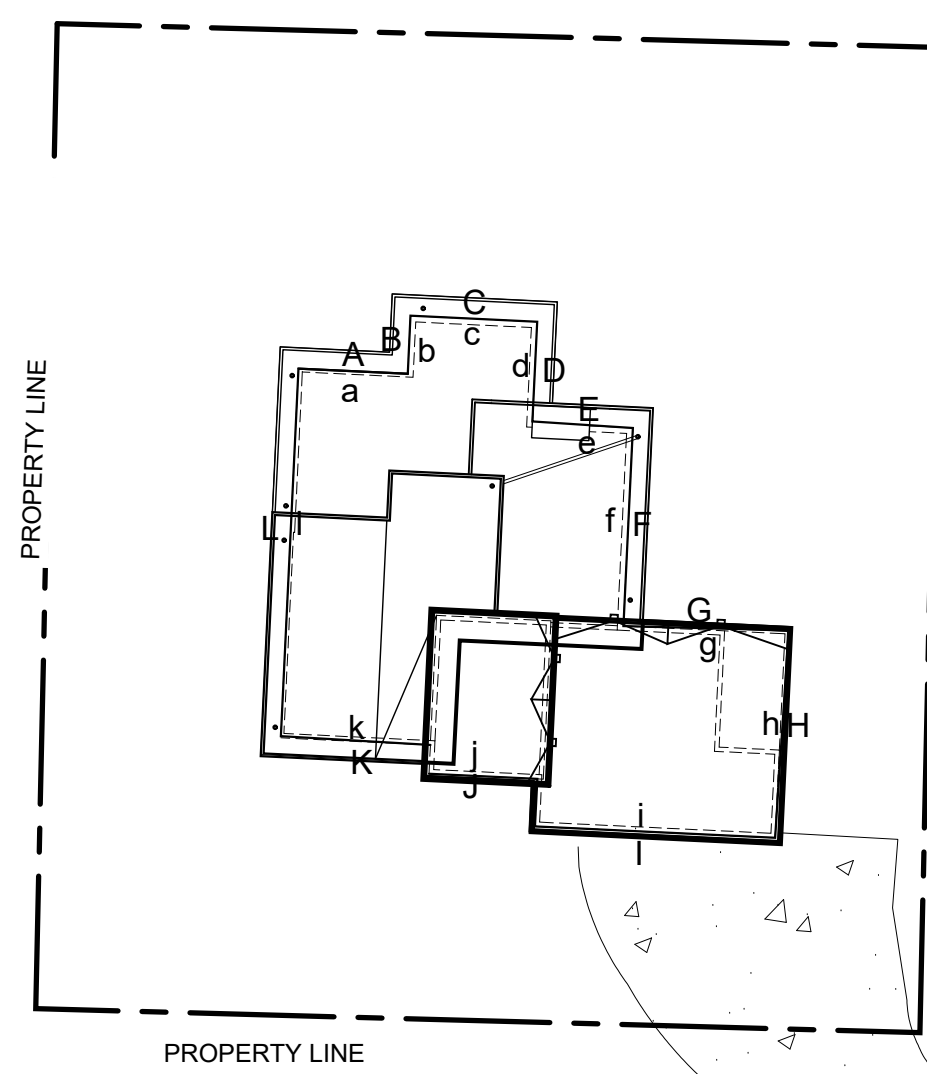

MIDPOINT ELEV	WALL SEG LENGTH
A 214.2 FT	a 11 FT
B 212 FT	b 6 FT
C 207.3 FT	c 13 FT
D 208 FT	d 10 FT
E 209 FT	e 10 FT
F 210.5 FT	f 21 FT
G 212.1 FT	g 17 FT
H 211.7 FT	h 21 FT
I 212 FT	i 25 FT
J 214.9 FT	j 11 FT
K 220 FT	k 15 FT
L 219.7 FT	l 38 FT

ABE CALCULATION
 $(214.2)(11)+(212)(6)+(207.3)(13)+(208)(10)+(209)(10)+(210.5)(21)+(212.1)(17)+(211.7)(21)+(212)(25)+(214.9)(11) + (220)(15)+(219.7)(38) / 11+6+13+10+10+21+17+21+25+11+15+38$

42277.5 / 198 = 213.5 FT ABE



STEEP SLOPE AREA

SEE GEOTECHNICAL REPORT + LETTER
 DETAILING PERMITTED CONSTRUCTION IN
 STEEP SLOPE CRITICAL AREA

4 STEEP SLOPE AREA
 1"=20'

HARDSCAPE-NEW	
TYPE	QTY (SF)
DECKS	343
SITE WALLS	31
WALKWAY	60
TOTAL	434
EXISTING - DEMO + NEW = PROPOSED	
2356	- 1941
434	= 849

LOT COVERAGE-NEW	
TYPE	QTY (SF)
GARAGE/BDRMS	672
TOTAL	672
EXISTING - DEMO + NEW = PROPOSED	
2876	- 714
672	= 2834

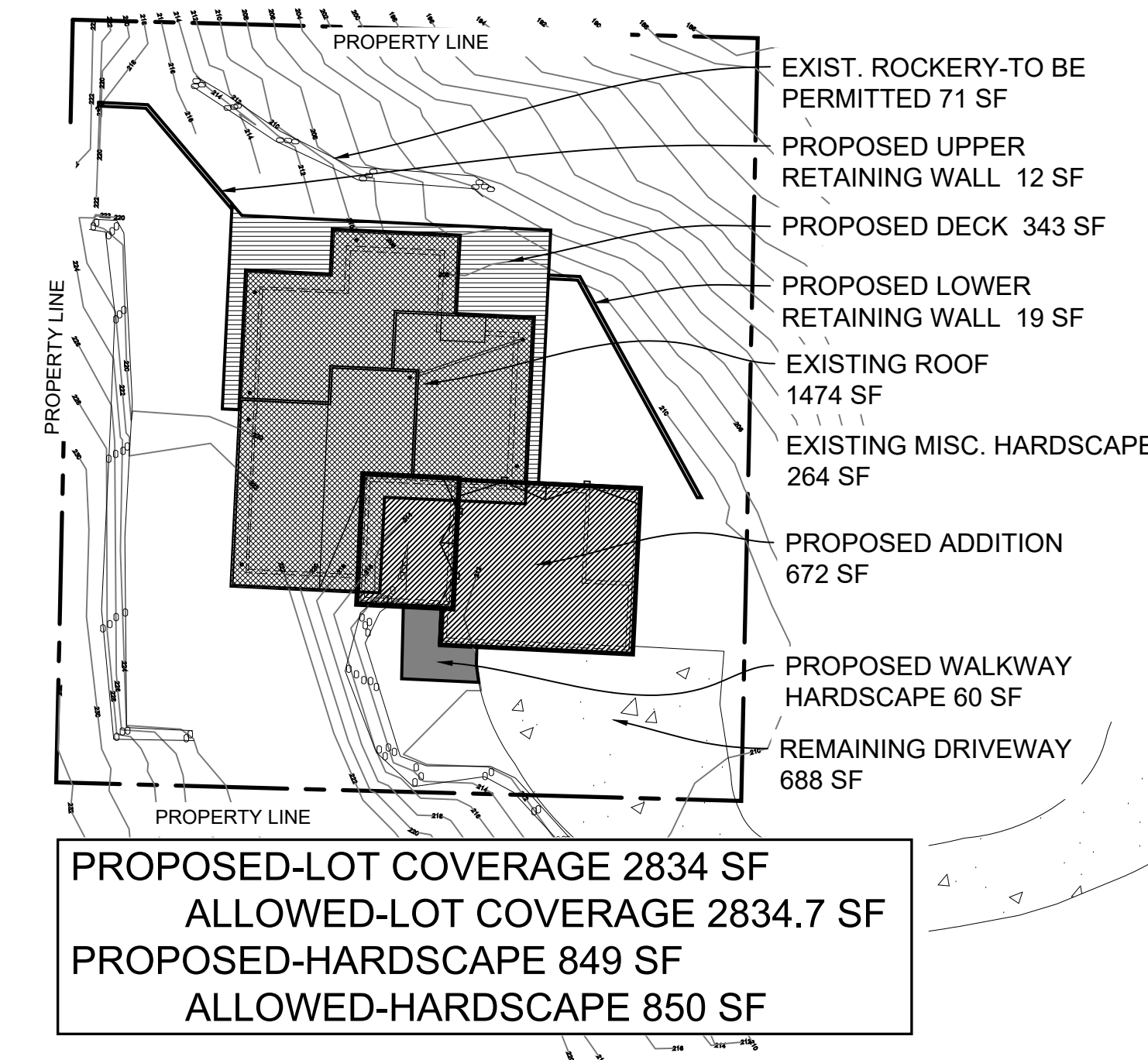

PROPOSED-LOT COVERAGE 2834 SF
 ALLOWED-LOT COVERAGE 2834.7 SF
 PROPOSED-HARDSCAPE 849 SF
 ALLOWED-HARDSCAPE 850 SF

3 PROPOSED LOT CONDITIONS
 1"=20'

5 AVERAGE BUILDING ELEV. CALC
 1"=20'



LSA

LIVING SHELTER ARCHITECTS PLLC

472-A FRONT ST. N
 ISSAQUAH, WA 98027
 (425) 427-8643

© 2018 LSA. All rights reserved.

file 1644

project name

BRENES REMODEL

project address
 2675 74th Ave SE
 Mercer Island, WA 98040

owner
 CHRIS & JEN BRENES
 619.957.5849
 jenniferbrenes@comcast.net

project manager
 ROY MCGARRAH
 living shelter architects
 425.427.8643
 roy@livingshelter.com

survey
 C & C SURVEYING, LLC
 425.673.7502
 ccsurveyllc@gmail.com

structural engineer
 SWENSON SAY FAGET
 206.443.6212
 info@ssfengineers.com

geotechnical engineer
 EARTH SOLUTIONS NW
 425.284.3300
 kevenh@esnw.com



revisions
 1 REV: 2/13/20

date
 16 JAN 2020

sheet title

LOT COVERAGE/HARDSCAPE

sheet number

A0.01



LSA

LIVING SHELTER ARCHITECTS PLLC

472-A FRONT ST. N
ISSAQUAH, WA 98027
(425) 427-8643

© 2018 LSA. All rights reserved.

file 1644

project name

BRENES REMODEL

project address
2675 74th Ave SE
Mercer Island, WA 98040

owner
CHRIS & JEN BRENES
619.957.5849
jenniferbrenes@comcast.net

project manager
ROY MCGARRAH
living shelter architects
425.427.8643
roy@livingshelter.com

survey
C & C SURVEYING, LLC
425.673.7502
ccsurveyllc@gmail.com

structural engineer
SWENSON SAY FAGET
206.443.6212
info@ssfengineers.com

geotechnical engineer
EARTH SOLUTIONS NW
425.284.3300
kevenh@esnw.com

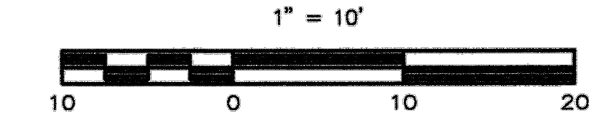
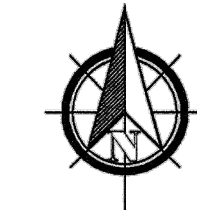

FOR COMPLETE HORIZONTAL CONTROL, REFERENCE RECORD OF SURVEY BY THIS FIRM DATED 10-2-2013, MAP FILE 3013RGS

LEGAL DESCRIPTION

THAT PORTION OF LOT 7, BLOCK 5, MCGILVRA'S ISLAND ADDITION, AS PER PLAT RECORDED IN VOLUME 16 OF PLATS, ON PAGE 58, RECORDS OF KING COUNTY, WASHINGTON, DESCRIBED AS FOLLOWS:
BEGINNING AT THE SOUTHEAST CORNER OF SAID LOT 7; AND RUNNING THENCE WEST, ALONG THE SOUTH LINE THEREOF, 92.15 FEET; THENCE NORTH, PARALLEL WITH THE EAST LINE OF SAID LOT 7, A DISTANCE OF 102.65 FEET; THENCE EAST TO THE EAST LINE OF SAID LOT 7, A DISTANCE OF 92.15 FEET; THENCE SOUTH, ALONG THE EAST LINE OF SAID LOT 7, A DISTANCE OF 102.65 FEET TO THE POINT OF BEGINNING.
(FROM TRUSTEE'S STATUTORY WARRANTY DEED, REC. NO. 20071002000874, RECORDS OF KING COUNTY, WASHINGTON)
CONTAINS 9,454.2 SQ FT (0.22 AC.)

VERTICAL DATUM

VERTICAL DATUM - NAVD 88. POINT NAME 8240 (CITY OF MERCER ISLAND). 2" BRASS CAP WITH "X" IN CONCRETE IN STEEL CASE AT INT. SE 27TH ST & 72ND AVE SE. ELEV = 259.04
SITE BENCHMARK - MOST WESTERLY BONNET BOLT ON FIRE HYDRANT AT SOUTHEASTERLY END OF SITE DRIVE, BOLT NORTH OF "M" IN "MULLER". ELEV = 196.11

TREE DESIGNATIONS:
(NUMBERS INDICATE DIAMETER -
I.E. CE 10" CEDAR TREE)
CE = CEDAR

SURVEYOR'S NOTES

- 1.) THE CONTROLS SHOWN REPRESENT A COMPILATION OF MEASUREMENTS MADE DURING THIS SURVEY, PREVIOUS SURVEYS PERFORMED BY THIS FIRM, PUBLIC RECORDED SURVEYS AND MUNICIPAL RECORDS.
- 2.) THE CONTROLLING MONUMENTATION WAS FOUND IN JULY, 2010. CONDITIONS NOTED ARE AS OF SEPTEMBER 20, 2013.
- 3.) FIELD INSTRUMENTATION WAS A LEICA TCPR 1203 TOTAL STATION LAST CALIBRATED WITHIN THE YEAR BY A FACTORY AUTHORIZED TECHNICIAN.
- 4.) THIS SURVEY MEETS OR EXCEEDS FIELD TRAVERSE STANDARDS PER WAC 332-130.
- 5.) ANY ENCROACHMENTS SHOWN HEREON MAY OR MAY NOT INDICATE UNWRITTEN PROPERTY RIGHTS.
- 6.) THE BOUNDARY MARKERS AND LINES DEPICTED ON THIS MAP ARE PER RECORD TITLE INFORMATION AND REPRESENT DEED LINES ONLY. THEY DO NOT PURPORT TO SHOW OWNERSHIP LINES THAT MAY OTHERWISE BE DETERMINED BY A COURT OF LAW, WHERE DISCREPANCIES EXIST THE SURVEYOR RECOMMENDS THAT THE OWNER OR POTENTIAL PURCHASER CONSULT WITH LEGAL COUNSEL TO DETERMINE HOW BEST TO INTERPRET THEIR PROPERTY RIGHTS AND ADDRESS ANY POTENTIAL BOUNDARY DISPUTES.
- 7.) FENCE LINES ARE SHOWN AS MEASURED TO THE CENTERLINE OF THE FENCE POSTS.
- 8.) TREES ARE MEASURED TO CENTERLINES OF TRUNKS.
- 9.) ALL DIMENSIONS NOTED ARE SHOWN IN U.S. FEET.
- 10.) OFFSETS AND SETBACKS ARE SHOWN PERPENDICULAR TO SIDE LINES.
- 11.) THE DRAWING SHOWN HEREON DOES NOT NECESSARILY CONTAIN ALL OF THE INFORMATION OBTAINED OR DEVELOPED BY THE SURVEYOR IN HIS FIELD WORK, OFFICE WORK, OR RESEARCH.
- 12.) THIS SURVEY WAS PERFORMED WITHOUT THE BENEFIT OF A TITLE REPORT AND DOES NOT PURPORT TO SHOW ANY OR ALL EASEMENTS OF RECORD.

1 SITE SURVEY - CURRENT CONDITIONS
NTS

THIS SITE SURVEY SHOWS EXISTING CONDITIONS SINCE 2017, INCLUDING NON-PERMITTED ROCKERIES ON THE NORTH SLOPE AND DECKS WRAPPING AROUND THE HOUSE FROM WEST, TO NORTH, TO EAST.

COPYRIGHT 2019 C&C SURVEYING LLC, ITS SUCCESSORS AND/OR ASSIGNS. ALL RIGHTS RESERVED. NO PART OF THIS DRAWING MAY BE REPRODUCED BY PHOTOCOPYING, RECORDING OR BY ANY OTHER MEANS, OR STORED, PROCESSED OR TRANSMITTED BY ANY COMPUTER OR OTHER SYSTEMS WITHOUT THE PRIOR WRITTEN PERMISSION OF THE SURVEYOR. COPIES OF THIS PLAN WITHOUT AN ORIGINAL SIGNATURE AND SURVEYOR'S SEAL ARE NOT VALID. THIS DRAWING IS THE PROPERTY OF C&C SURVEYING LLC, ITS SUCCESSORS AND/OR ASSIGNS. ANY UNAUTHORIZED USE OR REPRODUCTION OF THIS DRAWING WILL BE SUBJECT TO CIVIL PENALTIES.

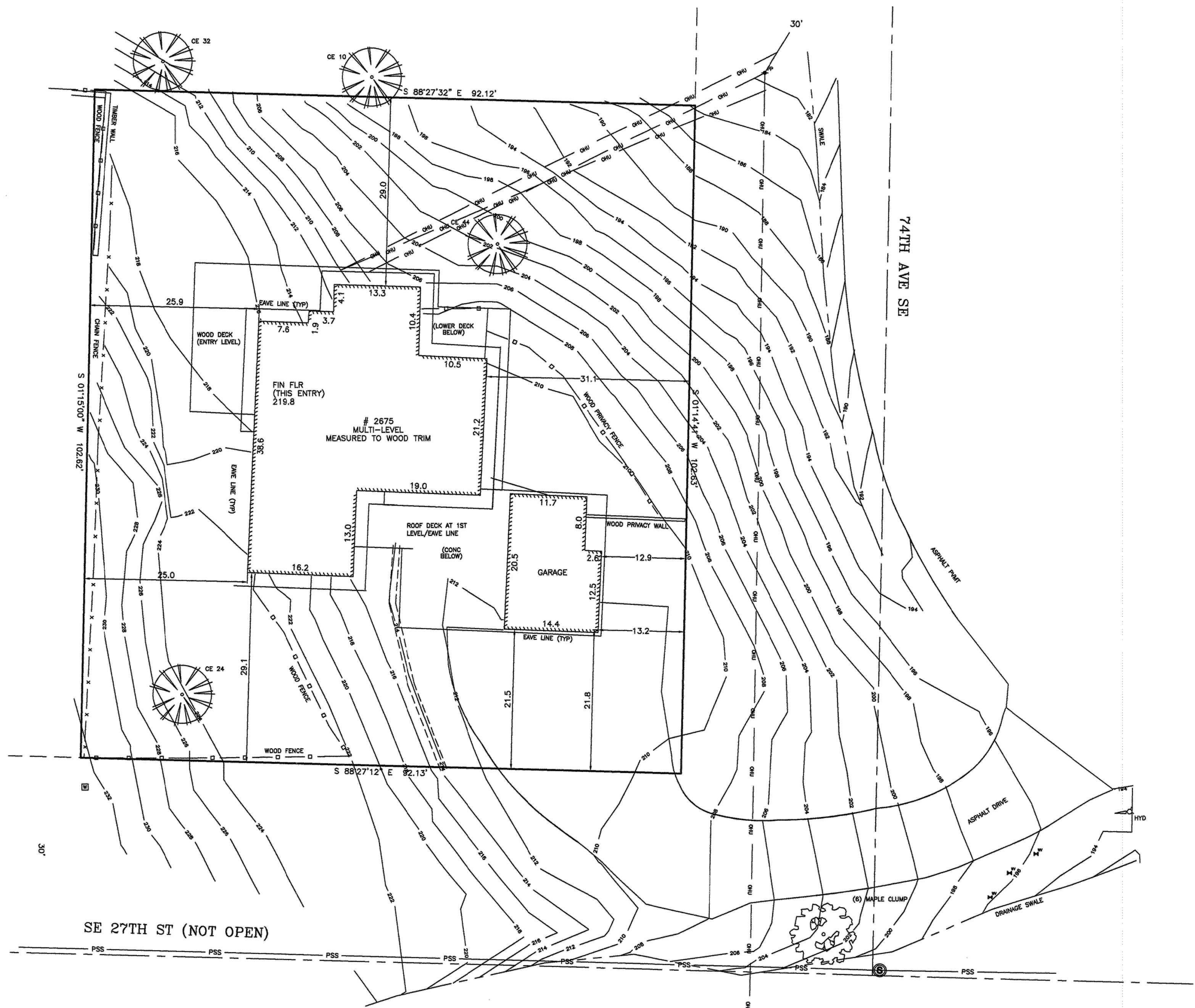

F:\MasterData\2013\3013 Brenes Drawings\3013TOPO_7-22-19.dwg, C&C Surveying LLC, Copyright: 2019

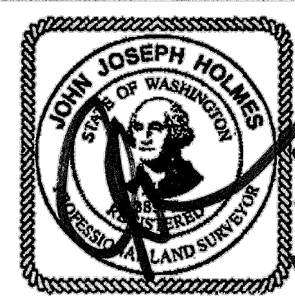

C & C Surveying LLC
4509 243rd PL SW
Mountlake Terrace, WA 98043
(425)673-7502 ccsurveyllc@gmail.com

TOPOGRAPHY SURVEY FOR
JENNIFER BRENES
2675 - 74TH AVENUE SOUTHEAST PROJECT

No.	Date	By	Revision	PROJ. NO. 3013
1	7.22.19	JJH	LOGO AND COPYRIGHT UPDATE	

revisions
1 REV: 2/13/20

date
16 JAN 2020

sheet title

SITE SURVEY

sheet number

A0.02

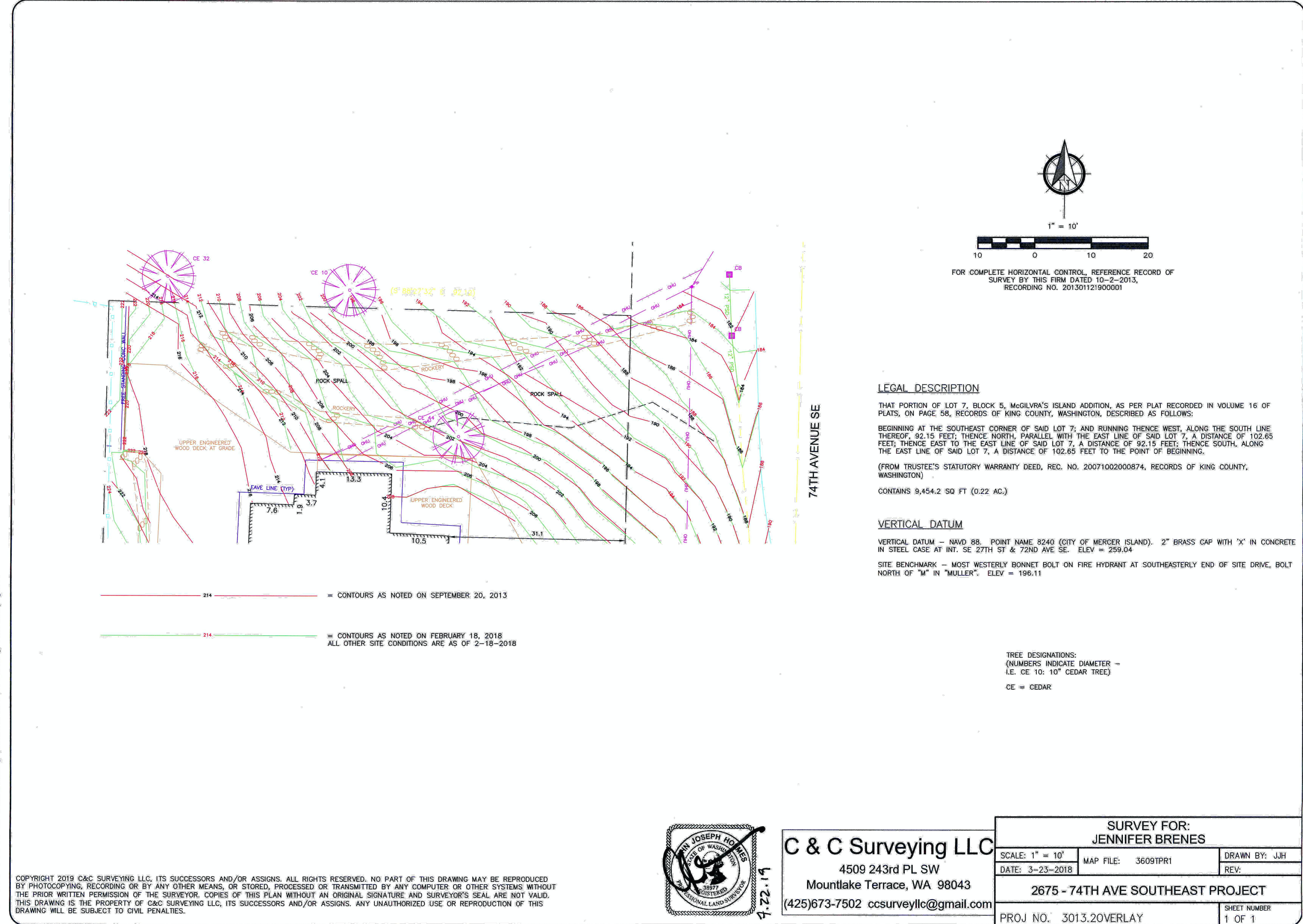

F:\Chester\Data\2013\3013 Brenes_Drawings\3013.20OVERLAY_7.22.19.dwg, C&C Surveying, LLC

COPYRIGHT 2019 C&C SURVEYING, LLC, ITS SUCCESSORS AND/OR ASSIGNS. ALL RIGHTS RESERVED. NO PART OF THIS DRAWING MAY BE REPRODUCED BY PHOTOCOPYING, RECORDING OR BY ANY OTHER MEANS, OR STORED, PROCESSED OR TRANSMITTED BY ANY COMPUTER OR OTHER SYSTEMS WITHOUT THE PRIOR WRITTEN PERMISSION OF THE SURVEYOR. COPIES OF THIS PLAN WITHOUT AN ORIGINAL SIGNATURE AND SURVEYOR'S SEAL ARE NOT VALID. THIS DRAWING IS THE PROPERTY OF C&C SURVEYING, LLC, ITS SUCCESSORS AND/OR ASSIGNS. ANY UNAUTHORIZED USE OR REPRODUCTION OF THIS DRAWING WILL BE SUBJECT TO CIVIL PENALTIES.



C & C Surveying LLC
 4509 243rd PL SW
 Mountlake Terrace, WA 98043
 (425)673-7502 ccsurveyllc@gmail.com

SURVEY FOR: JENNIFER BRENES		
SCALE: 1" = 10'	MAP FILE: 3609TPR1	DRAWN BY: JJH
DATE: 3-23-2018		REV:
2675 - 74TH AVE SOUTHEAST PROJECT		
PROJ. NO. 3013.20OVERLAY	SHEET NUMBER 1 OF 1	

1 SITE SURVEY - COMPARATIVE TOPO PRE/POST ROCKERIES
 NTS

THIS SITE DRAWING SHOWS CONTOURS SURVEYED IN 2013, BEFORE ROCKERIES WERE INSTALLED ON THE NORTH SLOPE OF THE BRENES' PROPERTY AND A COMPARATIVE SET OF CONTOURS SURVEYED AFTER THEIR CONSTRUCTION IN 2018.

THE LOWER ROCKERY WILL BE REMOVED, PER SITE PLAN, AND CONTOURS RETURNED TO PREVIOUS STATE SHOWN HERE FROM 2013.

revisions

1 REV: 2/13/20

date
 16 JAN 2020

sheet title

COMPARATIVE SITE SURVEY

sheet number

A0.03

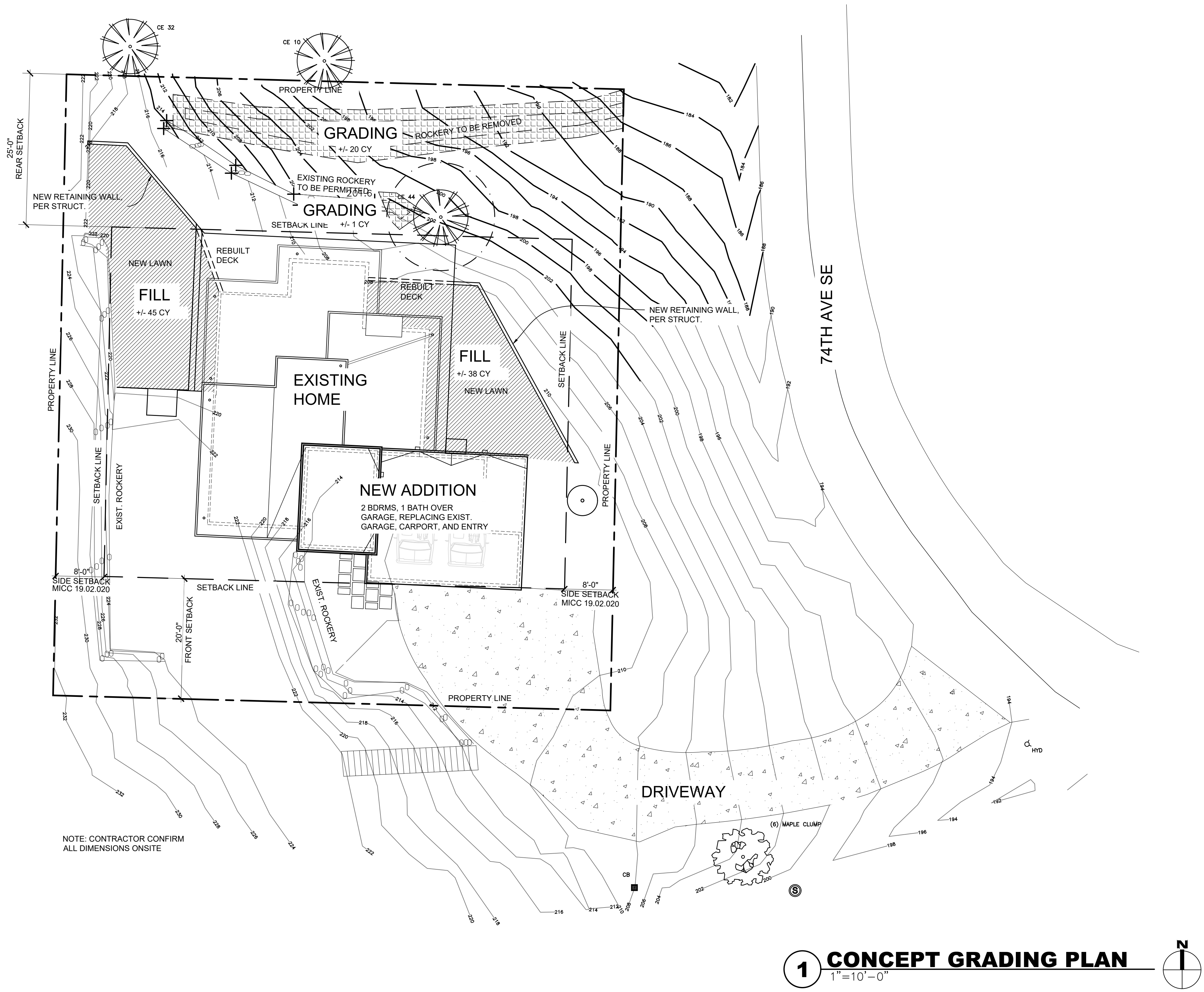

NOTE: CONTRACTOR CONFIRM ALL DIMENSIONS ONSITE

1 CONCEPT GRADING PLAN
1"=10'-0"

GRADING WILL OCCUR ON NORTH SLOPE OF PROPERTY WHERE LOWER ROCKERY AND A SMALL SECTION OF THE UPPER ROCKERY WILL BE REMOVED. GRADE WILL BE CONTOURED BACK TO ITS ORIGINAL SLOPE, PRE-ROCKERY. ROUGHLY 21 CUBIC YARDS OF SOIL WILL BE MOVED IN THE PROCESS.

ABOVE THE TWO NEW SITE RETAINING WALLS ROUGHLY 83 CUBIC YARDS OF FILL WILL BE ADDED TO CREATE LEVEL LAWNS WHERE DECKS ONCE STOOD.

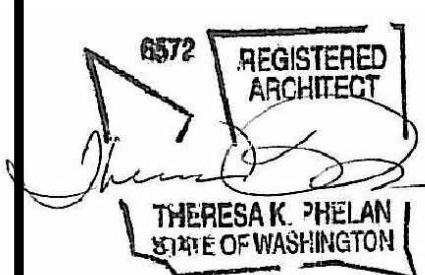

revisions
1 REV: 2/13/20

date
16 JAN 2020

sheet title
CONCEPTUAL GRADING PLAN

sheet number

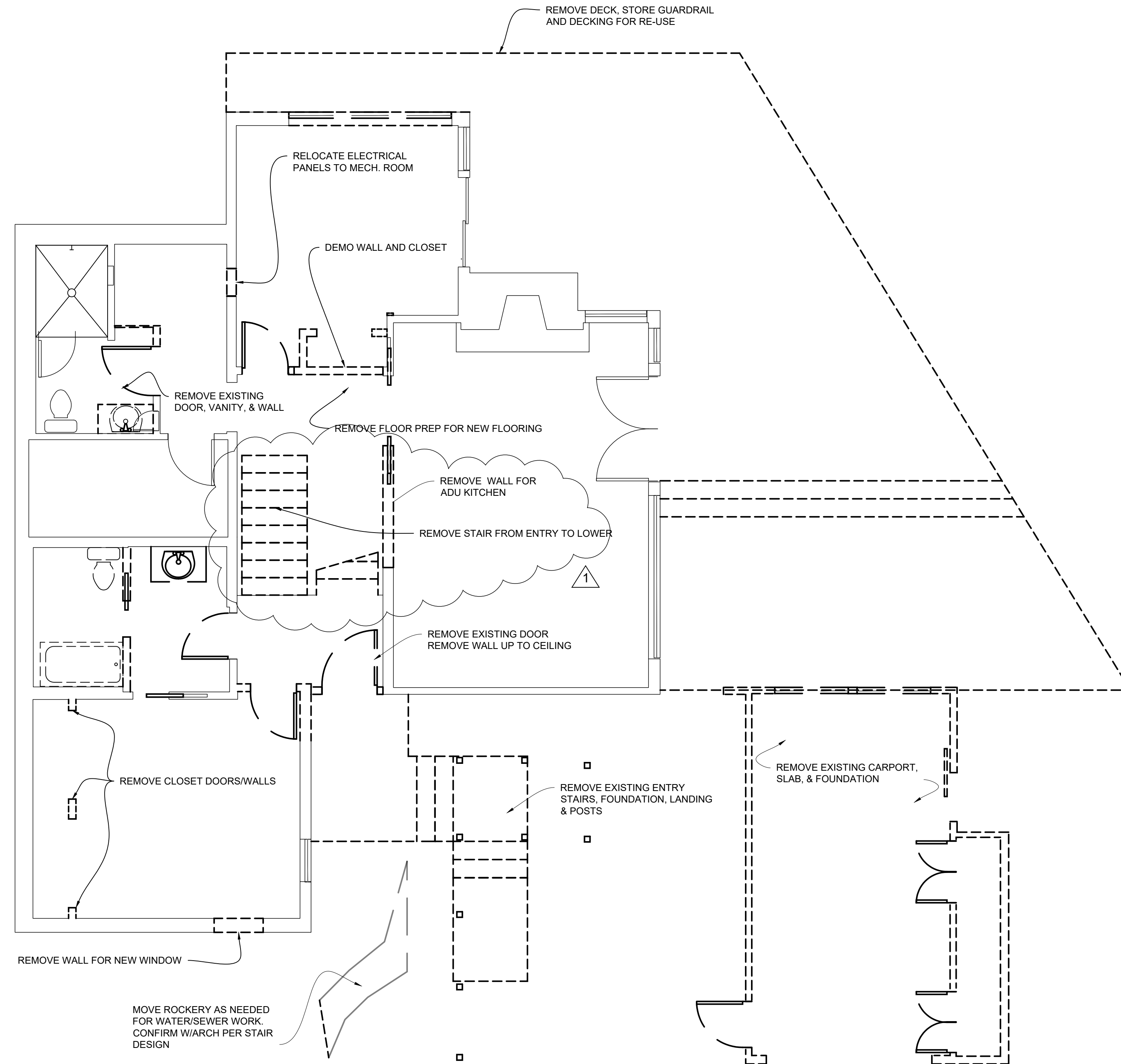

1 LOWER FLOOR DECONSTRUCTION PLAN
1/4"=1'-0"



WALL SYMBOL LEGEND:

- DEMO WALL
- EXISTING WALL

DECONSTRUCTION NOTES:
(see sheet G0.01 for additional notes)

1. Submit jobsite recycling plan prior to start of construction.
 - A. Achieve a minimum recycling rate of 70% of waste by weight.
 - B. Follow recycling plan once posted on jobsite.
2. All sub/contractors to comply with recycling plan & waste reduction efforts. Example of materials to recycle: cardboard, metal scrap, wood scrap, broken pallets, packaging, concrete rubble, rock, brick, land clearing/ yard waste, soil, other construction materials and surplus as appropriate.
3. Salvage existing window, door, cabinetry, and materials to preserve their integrity in order to be reused, donated, or recycled. Coordinate w/owner.
4. Demolish and remove existing partitions and walls as shown. This work also includes removing and properly abandoning existing electrical wiring in deconstruction areas.
5. During the deconstruction and construction processes, the contractor shall provide all bracing and temporary support as required to maintain building integrity. The contractor shall consult with the architect regarding any questionable situations, prior to proceeding with the work.
6. Remove existing finishes on ceiling and walls as required to allow installation of new framing, plumbing, and electrical wiring.
7. All existing framing cavities which are exposed during construction shall be filled to the full depth with batt insulation or insulation having an equivalent nominal R-value while, for roof/ceiling, maintaining the required space for ventilation per WSEC requirements.
8. All new work and materials, whether patching at remodeled areas, or new finish on existing construction, shall be executed in a manner which matches existing adjacent finishes and which conceals all interfaces between old and new work. Patching must be executed in a manner which is acceptable to the owner.
9. The contractor is to provide and install plastic sheeting to thoroughly seal off areas of remodeling from areas which are to remain intact. Sheeting to remain in place during entire deconstruction and construction processes, except as required to gain access and egress from construction area.
10. The contractor is to provide and install temporary weather protection during deconstruction/construction to thoroughly seal off areas which are to remain intact, protecting them from the weather.



LSA
LIVING SHELTER ARCHITECTS PLLC

472-A FRONT ST. N
ISSAQUAH, WA 98027
(425) 427-8643

© 2018 LSA. All rights reserved.

file
1644

project name
BRENES REMODEL

project address
2675 74th Ave SE
Mercer Island, WA 98040

owner
CHRIS & JEN BRENES
619.957.5849
jenniferbrenes@comcast.net

project manager
ROY MCGARRAH
living shelter architects
425.427.8643
roy@livingshelter.com

survey
C & C SURVEYING, LLC
425.673.7502
ccsurveyllc@gmail.com

structural engineer
SWENSON SAY FAGET
206.443.6212
info@sfsengineers.com

geotechnical engineer
EARTH SOLUTIONS NW
425.284.3300
kevenh@esnw.com

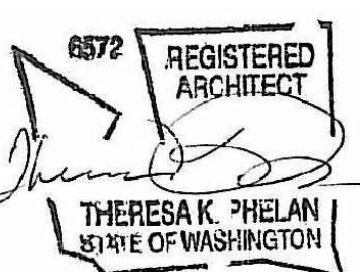

revisions
1 REV: 2/13/20

date
16 JAN 2020

sheet title

DECONSTRUCTION PLAN

sheet number

A1.01

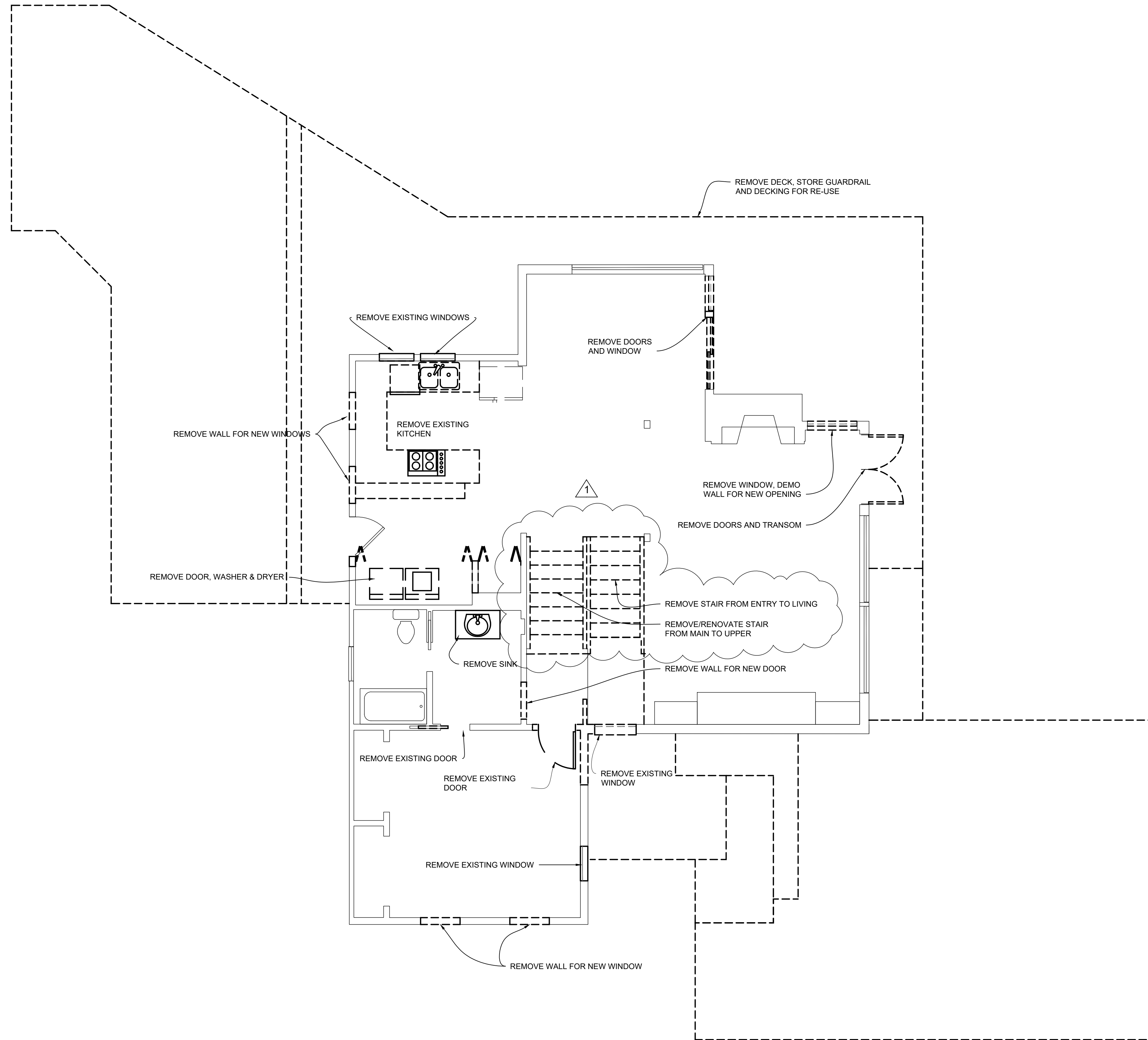

1 UPPER FLOOR DECONSTRUCTION PLAN
1/4"=1'-0"

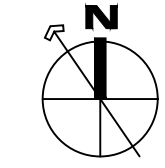

WALL SYMBOL LEGEND:
 - - - - - DEMO WALL
 _____ EXISTING WALL

DECONSTRUCTION NOTES:
(see sheet G0.01 for additional notes)

1. Submit jobsite recycling plan prior to start of construction.
 - A. Achieve a minimum recycling rate of 70% of waste by weight.
 - B. Follow recycling plan once posted on jobsite.
2. All sub/contractors to comply with recycling plan & waste reduction efforts.
 Example of materials to recycle: cardboard, metal scrap, wood scrap, broken pallets, packaging, concrete rubble, rock, brick, land clearing/ yard waste, soil, other construction materials and surplus as appropriate.
3. Salvage existing window, door, cabinetry, and materials to preserve their integrity in order to be reused, donated, or recycled. Coordinate w/owner.
4. Demolish and remove existing partitions and walls as shown. This work also includes removing and properly abandoning existing electrical wiring in deconstruction areas.
5. During the deconstruction and construction processes, the contractor shall provide all bracing and temporary support as required to maintain building integrity. The contractor shall consult with the architect regarding any questionable situations, prior to proceeding with the work.
6. Remove existing finishes on ceiling and walls as required to allow installation of new framing, plumbing, and electrical wiring.
7. All existing framing cavities which are exposed during construction shall be filled to the full depth with batt insulation or insulation having an equivalent nominal R-value while, for roof/ceiling, maintaining the required space for ventilation per WSEC requirements.
8. All new work and materials, whether patching at remodeled areas, or new finish on existing construction, shall be executed in a manner which matches existing adjacent finishes and which conceals all interfaces between old and new work. Patching must be executed in a manner which is acceptable to the owner.
9. The contractor is to provide and install plastic sheeting to thoroughly seal off areas of remodeling from areas which are to remain intact. Sheeting to remain in place during entire deconstruction and construction processes, except as required to gain access and egress from construction area.
10. The contractor is to provide and install temporary weather protection during deconstruction/construction to thoroughly seal off areas which are to remain intact, protecting them from the weather.



LSA
LIVING SHELTER ARCHITECTS PLLC

472-A FRONT ST. N
 ISSAQUAH, WA 98027
 (425) 427-8643

© 2018 LSA. All rights reserved.

file
 1644
 project name

BRENES REMODEL

project address
 2675 74th Ave SE
 Mercer Island, WA 98040

owner
 CHRIS & JEN BRENES
 619.957.5849
 jenniferbrenes@comcast.net

project manager
 ROY MCGARRAH
 living shelter architects
 425.427.8643
 roy@livingshelter.com

survey
 C & C SURVEYING, LLC
 425.673.7502
 ccsurveyllc@gmail.com

structural engineer
 SWENSON SAY FAGET
 206.443.6212
 info@sfsengineers.com

geotechnical engineer
 EARTH SOLUTIONS NW
 425.284.3300
 kevenh@esnw.com

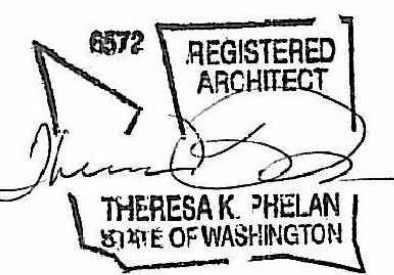

revisions
 1 REV: 2/13/20

date
 16 JAN 2020

sheet title

DECONSTRUCTION PLAN

sheet number

A1.02

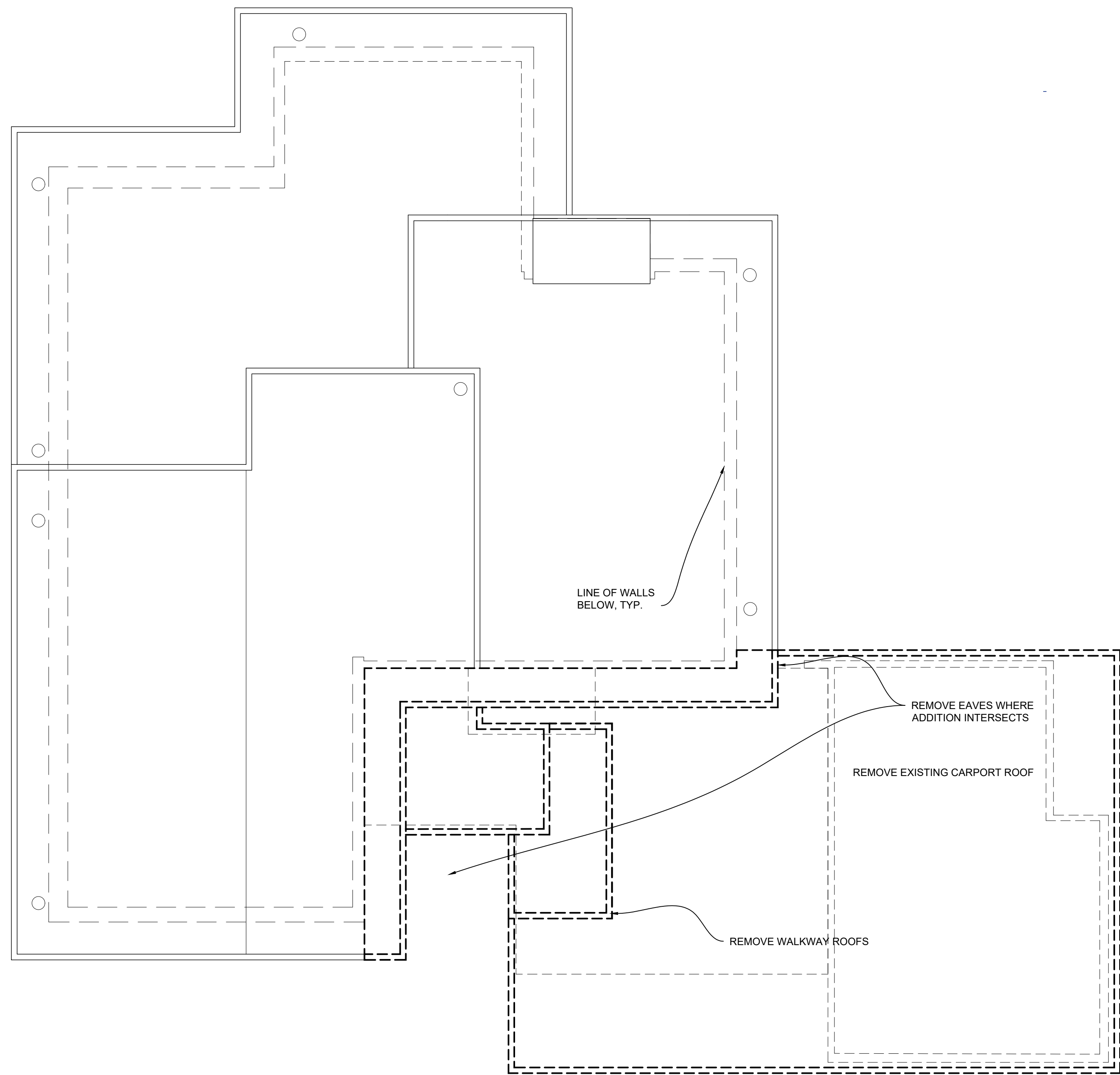

1 ROOF DECONSTRUCTION PLAN
1/4"=1'-0"



ROOF SYMBOL LEGEND:
 - - - - DEMO ROOF
 _____ EXISTING ROOF

DECONSTRUCTION NOTES:
(see sheet G0.01 for additional notes)

1. Submit jobsite recycling plan prior to start of construction.
 - A. Achieve a minimum recycling rate of 70% of waste by weight.
 - B. Follow recycling plan once posted on jobsite.
2. All sub/contractors to comply with recycling plan & waste reduction efforts.
Example of materials to recycle: cardboard, metal scrap, wood scrap, broken pallets, packaging, concrete rubble, rock, brick, land clearing/ yard waste, soil, other construction materials and surplus as appropriate.
3. Salvage existing window, door, cabinetry, and materials to preserve their integrity in order to be reused, donated, or recycled. Coordinate w/owner.
4. Demolish and remove existing partitions and walls as shown. This work also includes removing and properly abandoning existing electrical wiring in deconstruction areas.
5. During the deconstruction and construction processes, the contractor shall provide all bracing and temporary support as required to maintain building integrity. The contractor shall consult with the architect regarding any questionable situations, prior to proceeding with the work.
6. Remove existing finishes on ceiling and walls as required to allow installation of new framing, plumbing, and electrical wiring.
7. All existing framing cavities which are exposed during construction shall be filled to the full depth with batt insulation or insulation having an equivalent nominal R-value while, for roof/ceiling, maintaining the required space for ventilation per WSEC requirements.
8. All new work and materials, whether patching at remodeled areas, or new finish on existing construction, shall be executed in a manner which matches existing adjacent finishes and which conceals all interfaces between old and new work. Patching must be executed in a manner which is acceptable to the owner.
9. The contractor is to provide and install plastic sheeting to thoroughly seal off areas of remodeling from areas which are to remain intact. Sheeting to remain in place during entire deconstruction and construction processes, except as required to gain access and egress from construction area.
10. The contractor is to provide and install temporary weather protection during deconstruction/construction to thoroughly seal off areas which are to remain intact, protecting them from the weather.



LSA

LIVING SHELTER ARCHITECTS PLLC

472-A FRONT ST. N
ISSAQUAH, WA 98027
(425) 427-8643

© 2018 LSA. All rights reserved.

file
1644

project name
BRENES REMODEL

project address
2675 74th Ave SE
Mercer Island, WA 98040

owner
CHRIS & JEN BRENES
619.957.5849
jenniferbrenes@comcast.net

project manager
ROY MCGARRAH
living shelter architects
425.427.8643
roy@livingshelter.com

survey
C & C SURVEYING, LLC
425.673.7502
ccsurveyllc@gmail.com

structural engineer
SWENSON SAY FAGET
206.443.6212
info@ssfengineers.com

geotechnical engineer
EARTH SOLUTIONS NW
425.284.3300
kevenh@esnw.com

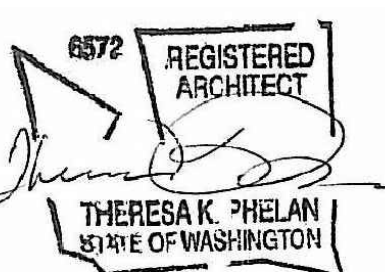

revisions
1 REV: 2/13/20

date
16 JAN 2020

sheet title

DECONSTRUCTION PLAN

sheet number

A1.03



LSA

LIVING SHELTER ARCHITECTS PLLC

472-A FRONT ST. N
ISSAQUAH, WA 98027
(425) 427-8643

© 2018 LSA. All rights reserved.

file

1644
project name

BRENES REMODEL

project address
2675 74th Ave SE
Mercer Island, WA 98040

owner
CHRIS & JEN BRENES
619.957.5849
jenniferbrenes@comcast.net

project manager
ROY MCGARRAH
living shelter architects
425.427.8643
roy@livingshelter.com

survey
C & C SURVEYING, LLC
425.673.7502
ccsurveyllc@gmail.com

structural engineer
SWENSON SAY FAGET
206.443.6212
info@ssfengineers.com

geotechnical engineer
EARTH SOLUTIONS NW
425.284.3300
kevenh@esnw.com

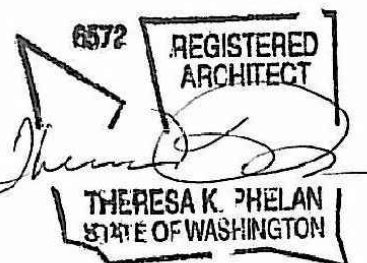

revisions
1 REV: 2/13/20

date
16 JAN 2020

sheet title

LOWER FLOOR PLAN

sheet number

A1.11

DRAWING NOTES

- Contractor shall verify all notes, dimensions & conditions prior to construction.
- Exterior walls to be 2x6 studs, per struct. - Interior walls to be 2x4 studs, per struct. -align w/ studs/rafters above and/or below where applicable.
- Plate heights to be aligned with existing. (U.N.O.).
- Insulate all headers. HDR= (2) 2x header @ 6'-8" above subflr. (U.N.O.).
- Indicates (2) 2x stud post in wall. Provide the following, U.N.O.:
 - at beam/header, provide (1) king stud.
 - at span of 3'-0" or less provide (1) trimmer stud.
 - at spans of more than 3'-0" provide (2) trimmer studs.
 - at intermediate supports of multiple spans use (2) 2x members.
- All framing hardware to be by "Simpson" (or equal), install per mfr's specs.
- Provide fire blocking @ all plumbing & stair penetrations, and other locations per IRC Sec. R602.8 and R302.11.
- Safety glaze hazardous locations per IRC Sec R308.4.3. Provide emergency escape per IRC Sec. R310.1.
- Max. riser height shall be 7-3/4". Min. tread depth shall be 10" per IRC Sec R311.7.5.
- Top of handrail shall be not less than 34" or more than 38" above the tread nosings. Handrails shall be continuous the full length of the flight. The hand grip portion shall not be less than 1-1/4" or more than 2" in cross-sectional dimension. Handrails adjacent to walls shall have min. 1-1/2" space between the wall & handrail.
- Provide guards and guardrails per IRC Sec. R312.1.2.
- Install smoke alarms in locations per IRC Sec. R314. Smoke detectors to be 110v, permanently wired w/o disconnect switch, interconnected, w/battery backup.
- Provide garage/dwelling unit separation per IRC Sec. R302.6
- Provide 2 layers of 30# felt in place of P.T. lumber in locations per IRC Sec. R317.1.
- See sheet G0.02 for window and door schedules.
- See sheet S4.1 for shear wall schedule.

PLAN NOTES:

(see sheet G0.00 and G0.01 for additional notes)

MATERIALS

- Use low toxic/low volatile organic compound (VOC) materials where possible throughout project, especially on interior surfaces.
 - A. Examples include: paints & finishes, water based products, solvent-free sealers, grouts, mortars, calks, and adhesives.
- Limit pressure treated (P.T.) components: no wood treated with chromated copper arsenate (CCA) or ammoniacal copper arsenate (ACA) may be used on this job. Wood treated with alkaline/copper/quaternary (ACQ) is acceptable.
- Provide F.S.C. (Forest Stewardship Council) Certified lumber to greatest extent possible. (Available at Ecohaus and Dunn Lumber in Seattle.)
- Steel shall be certified min. 80% recycled content.
- Provide fly ash in concrete mix.
- Use plywood and composites of exterior grade or formaldehyde-free (for interior use).
- Use polyethylene piping for plumbing (i.e. PEX)
- Avoid PVC throughout project to the greatest extent possible.
- Use 75% minimum Energy Star light fixtures.

METHODS

- Submit jobsite recycling plan prior to start of construction.
 - A. Achieve a minimum recycling rate of 70% of waste by weight.
 - B. Follow recycling plan once posted on jobsite.
- All sub/contractors to comply with recycling plan & waste reduction efforts. Example of materials to recycle: cardboard, metal scrap, wood scrap, broken pallets, packaging, concrete rubble, rock, brick, land clearing/ yard waste, soil, other construction materials and surplus as appropriate.
- Allow proper ventilation and curing time for strong construction compounds.
- Sub/contractor to notify owner prior to use of compounds/materials with strong odors.
- Seal at doors, windows, plumbing & electrical penetrations against moisture and air leaks, refer to flashing details.

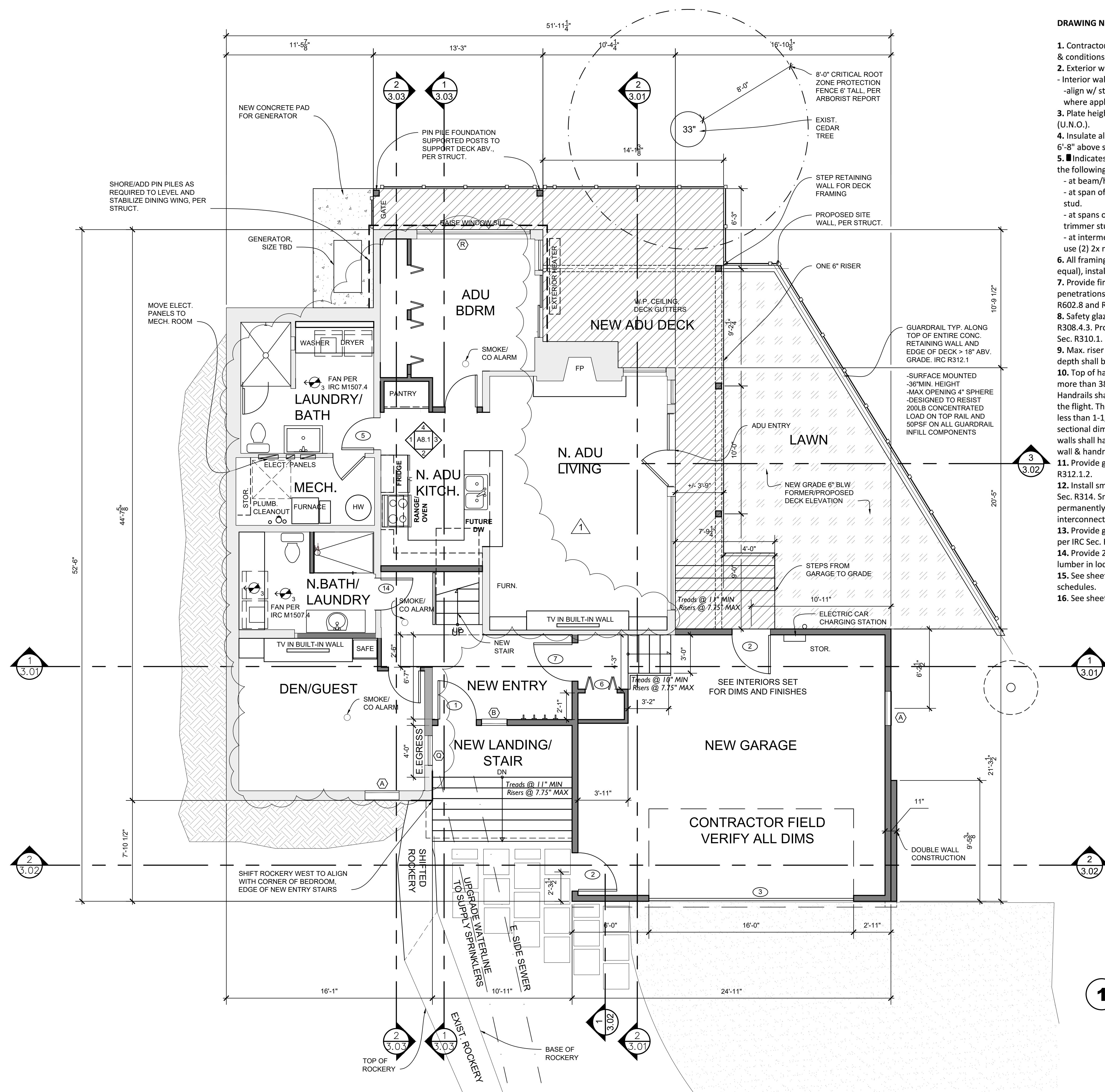

1 LOWER FLOOR PLAN
1/4"=1'-0"

WALL SYMBOL LEGEND:

	NEW 2X WALL
	NEW 2X HALF WALL
	EXISTING WALL

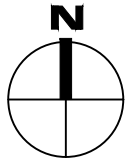

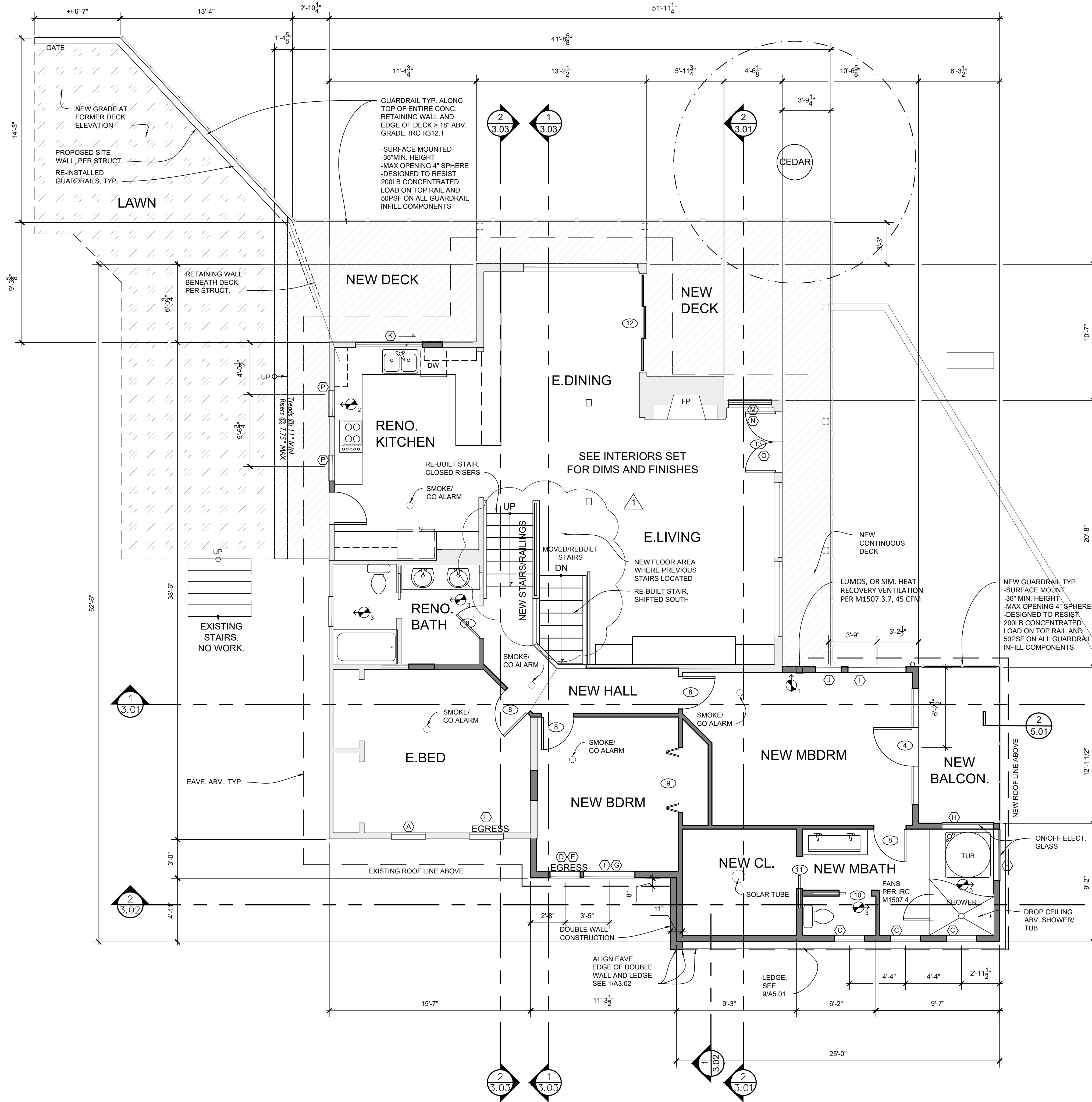

DRAWING NOTES

- Contractor shall verify all notes, dimensions & conditions prior to construction.
- Exterior walls to be 2x6 studs, per struct. - Interior walls to be 2x4 studs, per struct. -align w/ studs/rafters above and/or below where applicable.
- Plate heights to be aligned with existing. (U.N.O.).
- Insulate all headers. HDR= (2) 2x header @ 6'-8" above subfr. (U.N.O.).
- Indicates (2) 2x stud post in wall. Provide the following, U.N.O.:
 - at beam/header, provide (1) king stud.
 - at span of 3'-0" or less provide (1) trimmer stud.
 - at spans of more than 3'-0" provide (2) trimmer studs.
 - at intermediate supports of multiple spans use (2) 2x members.
- All framing hardware to be by "Simpson" (or equal), install per mfr's specs.
- Provide fire blocking @ all plumbing & stair penetrations, and other locations per IRC Sec. R602.8 and R302.11.
- Safety glaze hazardous locations per IRC Sec R308.4.3. Provide emergency escape per IRC Sec. R310.1.
- Max. riser height shall be 7-3/4". Min. tread depth shall be 10" per IRC Sec R311.7.5.
- Top of handrail shall be not less than 34" or more than 38" above the tread nosings. Handrails shall be continuous the full length of the flight. The hand grip portion shall not be less than 1-1/4" or more than 2" in cross-sectional dimension. Handrails adjacent to walls shall have min. 1-1/2" space between the wall & handrail.
- Provide guards and guardrails per IRC Sec. R312.1.2.
- Install smoke alarms in locations per IRC Sec. R314. Smoke detectors to be 110v, permanently wired w/o disconnect switch, interconnected, w/battery backup.
- Provide garage/dwelling unit separation per IRC Sec. R302.6
- Provide 2 layers of 30# felt in place of P.T. lumber in locations per IRC Sec. R317.1.
- See sheet G0.02 for window and door schedules.
- See sheet S4.1 for shear wall schedule.

PLAN NOTES:

(see sheet G0.00 and G0.01 for additional notes)

MATERIALS

- Use low toxic/low volatile organic compound (VOC) materials where possible throughout project, especially on interior surfaces.
 - A. Examples include: paints & finishes, water based products, solvent-free sealers, grouts, mortars, calks, and adhesives.
- Limit pressure treated (P.T.) components: no wood treated with chromated copper arsenate (CCA) or ammoniacal copper arsenate (ACA) may be used on this job. Wood treated with alkaline/copper/quaternary (ACQ) is acceptable.
- Provide F.S.C. (Forest Stewardship Council) Certified lumber to greatest extent possible. (Available at Ecohaus and Dunn Lumber in Seattle.)
- Steel shall be certified min. 80% recycled content.
- Provide fly ash in concrete mix.
- Use plywood and composites of exterior grade or formaldehyde-free (for interior use).
- Use polyethylene piping for plumbing (i.e. PEX)
- Avoid PVC throughout project to the greatest extent possible.
- Use 75% minimum Energy Star light fixtures.

METHODS

- Submit jobsite recycling plan prior to start of construction.
 - A. Achieve a minimum recycling rate of 70% of waste by weight.
 - B. Follow recycling plan once posted on jobsite.
- All sub/contractors to comply with recycling plan & waste reduction efforts. Example of materials to recycle: cardboard, metal scrap, wood scrap, broken pallets, packaging, concrete rubble, rock, brick, land clearing/ yard waste, soil, other construction materials and surplus as appropriate.
- Allow proper ventilation and curing time for strong construction compounds.
- Sub/contractor to notify owner prior to use of compounds/materials with strong odors.
- Seal at doors, windows, plumbing & electrical penetrations against moisture and air leaks, refer to flashing details.

1 UPPER FLOOR PLAN
1/4"=1'-0"

WALL SYMBOL LEGEND:

	NEW 2X WALL
	NEW 2X HALF WALL
	EXISTING WALL

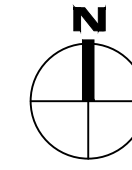

LSA
LIVING SHELTER ARCHITECTS PLLC

472-A FRONT ST. N
ISSAQUAH, WA 98027
(425) 427-8643

© 2018 LSA. All rights reserved.

file
1644
project name

BRENES REMODEL

project address
2675 74th Ave SE
Mercer Island, WA 98040

owner
CHRIS & JEN BRENES
619.957.5849
jenniferbrenes@comcast.net

project manager
ROY MCGARRAH
living shelter architects
425.427.8643
roy@livingshelter.com

survey
C & C SURVEYING, LLC
425.673.7502
ccsurveyllc@gmail.com

structural engineer
SWENSON SAY FAGET
206.443.6212
info@ssfengineers.com

geotechnical engineer
EARTH SOLUTIONS NW
425.284.3300
kevenh@esnw.com



revisions
1 REV: 2/13/20

date
16 JAN 2020

sheet title

UPPER FLOOR PLAN

sheet number

A1.12

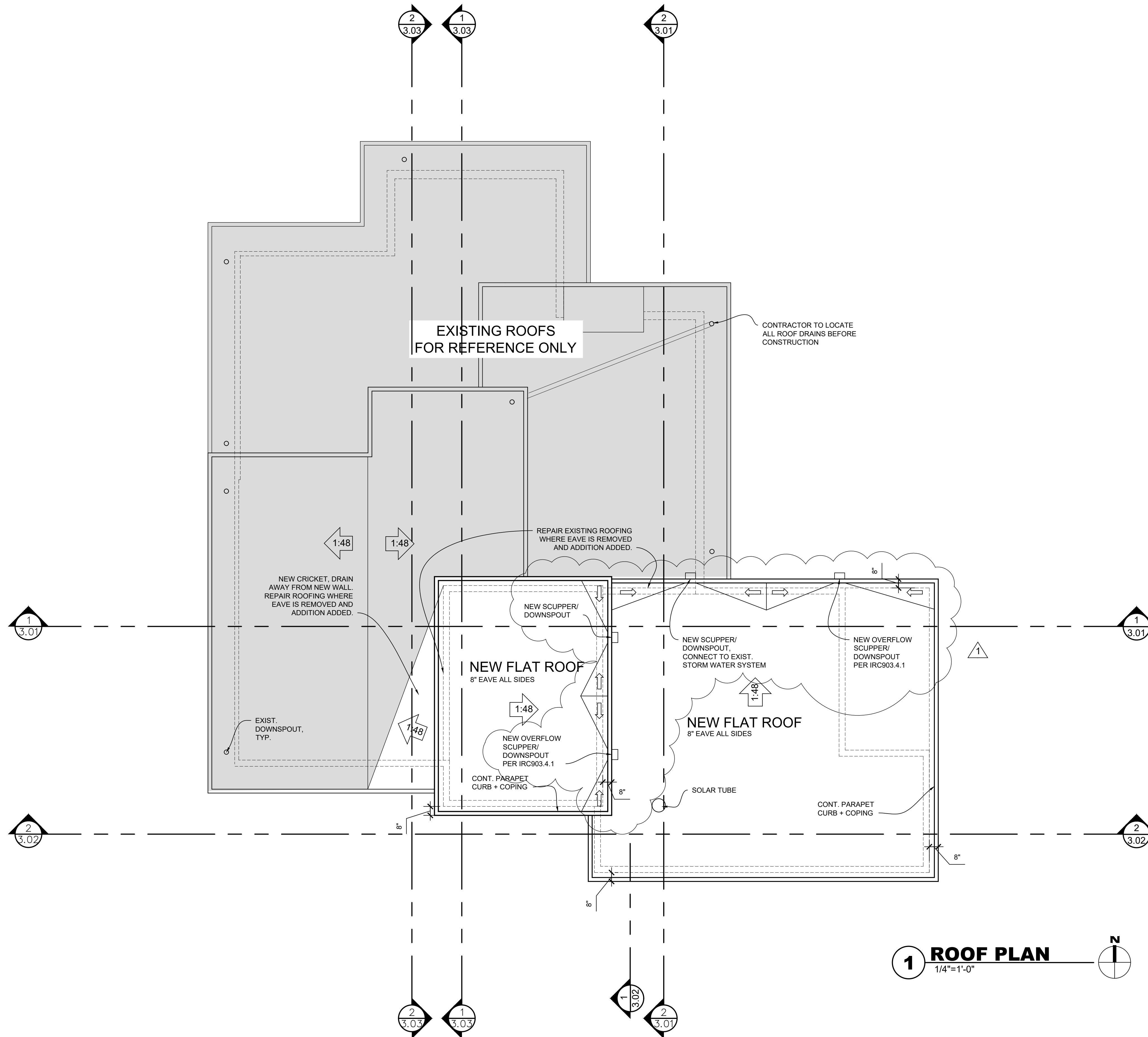

1 ROOF PLAN
1/4"=1'-0"

ROOF FRAMING NOTES:
(see sheet G0.01 for additional notes)

1. Contractor shall verify all notes, dimensions & conditions prior to construction.
2. All roof pitches and O.H. per plan.
3. Roof sheathing: 1/2" APA rated 40/20 sht'g, nail w/ 8d @ 4" O.C. edges, 12" O.C. field, typ. at roof. Install PSCL ply-clip at unsupported edge of roof sht'g. (U.N.O.).
4. Bearing walls are shaded.
5. Provide solid blk'g over supports- vented @ exterior walls.
6. All framing hardware to be by "Simpson Strong-Tie" (or equal), install per mfr's specs. Provide the following, U.N.O.:
 -at beam-to-beam connector, use wp series hanger(s) (slope and skew hanger(s) as appropriate).
 -at 2x rafter-to-beam connector, use lb series hanger(s).
 -at sloped or skewed 2x rafters, use ISSU210 hanger.
7. All trusses, if any:
 - shall carry mfr's stamp.
 - shall be installed & braced to mfr's specs.
 - shall have design details & shop drawings on site for inspection.
 - shall not be field altered without prior bldg dept. approval of engr. calcs.
 - shall include truss framing hardware & blocking (provided by truss mfr.)
8. Provide cross ventilation per IRC Sec. R806.1, if applicable.
9. Provide attic access per IRC Sec. R807.1 (22" x 30" min.) if applicable.
10. DS=downspout. Tightline to 4" solid pipe independent of ftg. drain & discharge to approved connection or outlet.



LSA
LIVING SHELTER ARCHITECTS PLLC

472-A FRONT ST. N
ISSAQUAH, WA 98027
(425) 427-8643

© 2018 LSA. All rights reserved.

file
1644
project name

BRENES REMODEL

project address
2675 74th Ave SE
Mercer Island, WA 98040

owner
CHRIS & JEN BRENES
619.957.5849
jenniferbrenes@comcast.net

project manager
ROY MCGARRAH
living shelter architects
425.427.8643
roy@livingshelter.com

survey
C & C SURVEYING, LLC
425.673.7502
ccsurveyllc@gmail.com

structural engineer
SWENSON SAY FAGET
206.443.6212
info@ssfengineers.com

geotechnical engineer
EARTH SOLUTIONS NW
425.284.3300
kevenh@esnw.com

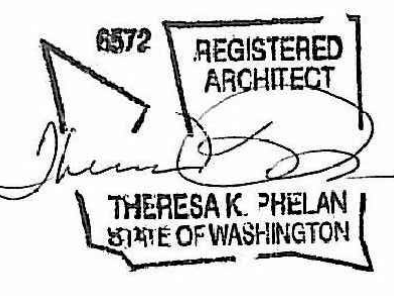

revisions
1 REV: 2/13/20

date
16 JAN 2020

sheet title

ROOF PLAN

sheet number

A1.13



LSA

LIVING SHELTER ARCHITECTS PLLC

472-A FRONT ST. N
ISSAQUAH, WA 98027
(425) 427-8643

© 2018 LSA. All rights reserved.

file
1644

project name
BRENES REMODEL

project address
2675 74th Ave SE
Mercer Island, WA 98040

owner
CHRIS & JEN BRENES
619.957.5849
jenniferbrenes@comcast.net

project manager
ROY MCGARRAH
living shelter architects
425.427.8643
roy@livingshelter.com

survey
C & C SURVEYING, LLC
425.673.7502
ccsurveyllc@gmail.com

structural engineer
SWENSON SAY FAGET
206.443.6212
info@ssfengineers.com

geotechnical engineer
EARTH SOLUTIONS NW
425.284.3300
kevenh@esnw.com

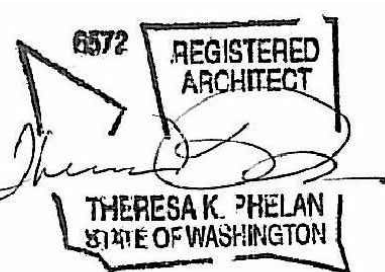

revisions
1 REV: 2/13/20

date
16 JAN 2020

sheet title

EXISTING ELEVATION

sheet number

A2.01

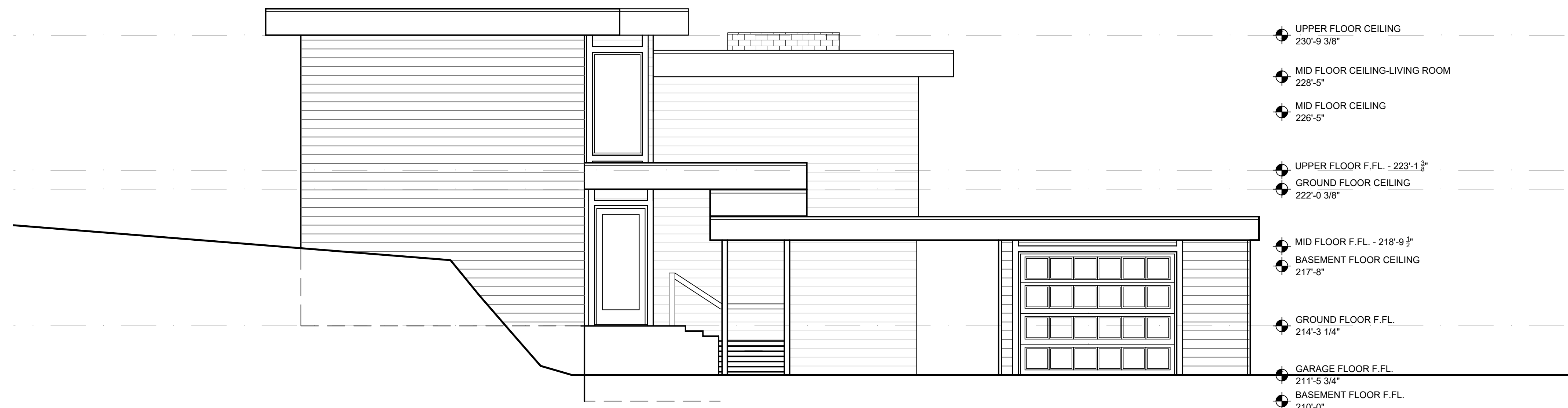

- UPPER FLOOR CEILING
230'-9 3/8"
- MID FLOOR CEILING-LIVING ROOM
228'-5"
- MID FLOOR CEILING
226'-5"
- UPPER FLOOR F.F.L. - 223'-1 3/8"
- GROUND FLOOR CEILING
222'-0 3/8"
- MID FLOOR F.F.L. - 218'-9 1/2"
- BASEMENT FLOOR CEILING
217'-8"
- GROUND FLOOR F.F.L.
214'-3 1/4"
- GARAGE FLOOR F.F.L.
211'-5 3/4"
- BASEMENT FLOOR F.F.L.
210'-0"

1 EXISTING SOUTH ELEVATION
1/4"=1'-0"



- UPPER FLOOR CEILING
230'-9 3/8"
- MID FLOOR CEILING-LIVING ROOM
228'-5"
- MID FLOOR CEILING
226'-5"
- UPPER FLOOR F.F.L. - 223'-1 3/8"
- GROUND FLOOR CEILING
222'-0 3/8"
- MID FLOOR F.F.L. - 218'-9 1/2"
- BASEMENT FLOOR CEILING
217'-8"
- GROUND FLOOR F.F.L.
214'-3 1/4"
- BASEMENT FLOOR F.F.L.
210'-0"

2 EXISTING EAST ELEVATION
1/4"=1'-0"



LSA

LIVING SHELTER ARCHITECTS PLLC

472-A FRONT ST. N
ISSAQUAH, WA 98027
(425) 427-8643

© 2018 LSA. All rights reserved.

file
1644
project name

BRENES REMODEL

project address
2675 74th Ave SE
Mercer Island, WA 98040

owner
CHRIS & JEN BRENES
619.957.5849
jenniferbrenes@comcast.net

project manager
ROY MCGARRAH
living shelter architects
425.427.8643
roy@livingshelter.com

survey
C & C SURVEYING, LLC
425.673.7502
ccsurveyllc@gmail.com

structural engineer
SWENSON SAY FAGET
206.443.6212
info@ssfengineers.com

geotechnical engineer
EARTH SOLUTIONS NW
425.284.3300
kevenh@esnw.com

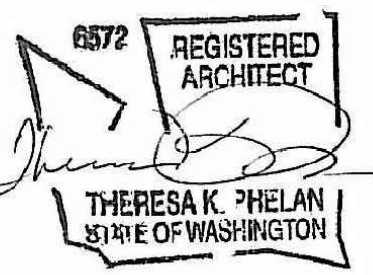

revisions
1 REV: 2/13/20

date
16 JAN 2020

sheet title

EXISTING ELEVATION

sheet number

A2.02



1 EXISTING NORTH ELEVATION
1/4"=1'-0"

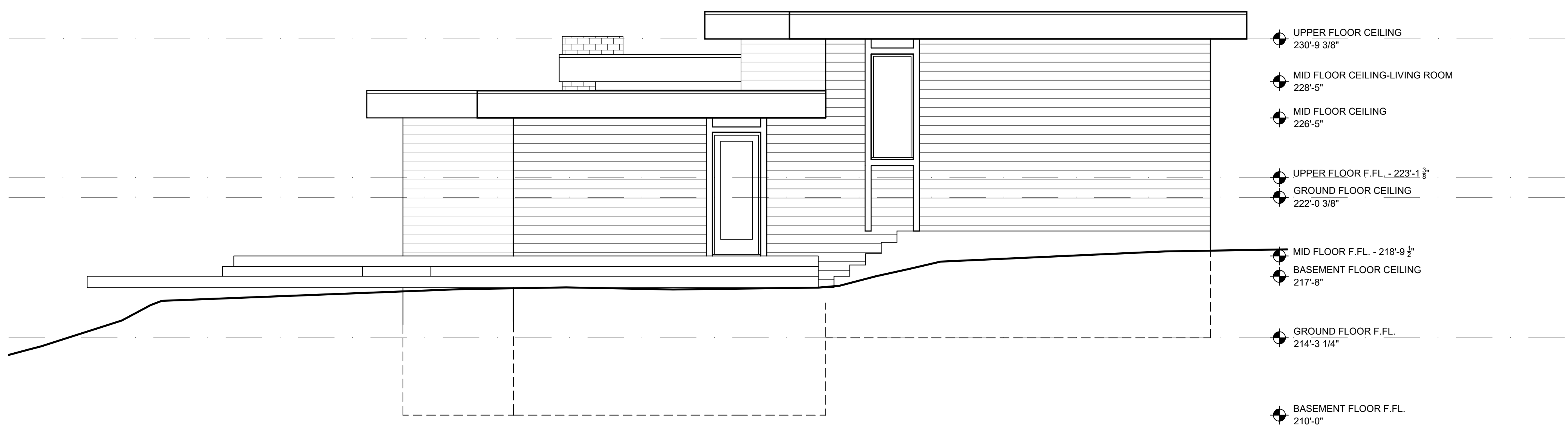

2 EXISTING WEST ELEVATION
1/4"=1'-0"

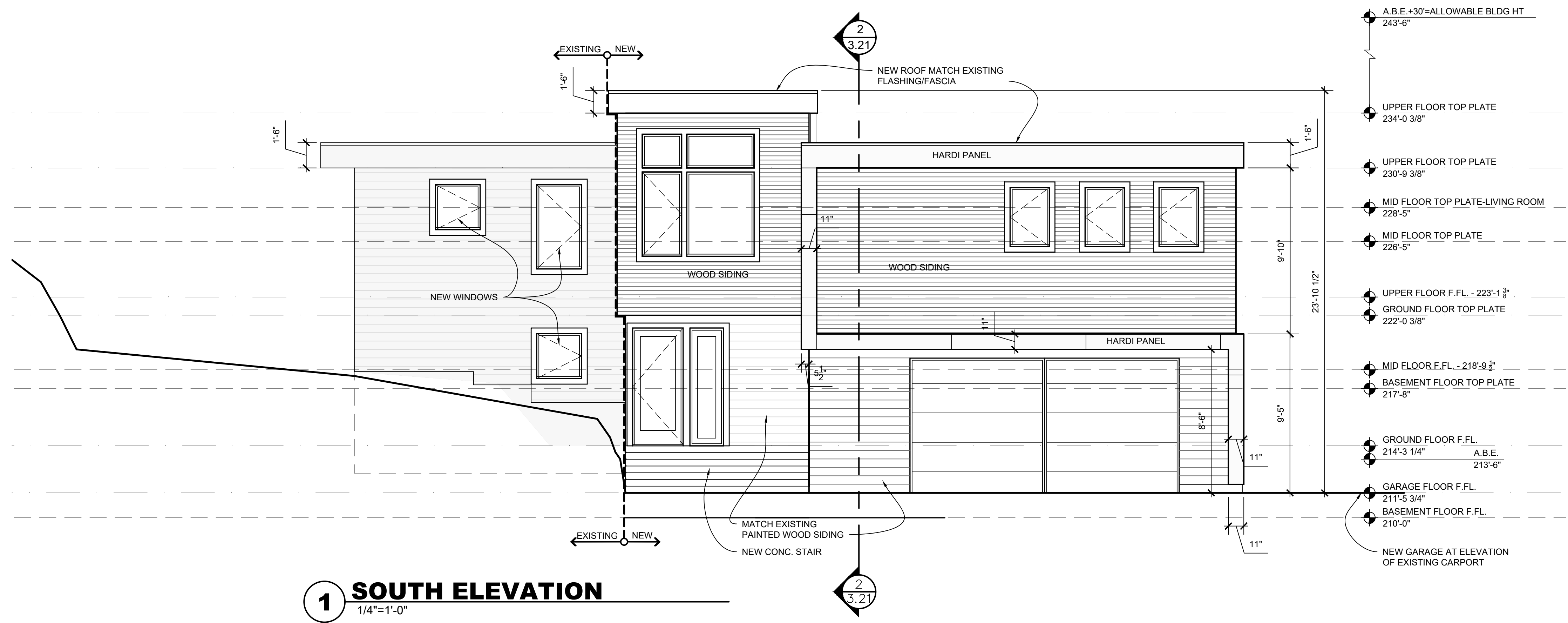

1 SOUTH ELEVATION
1/4"=1'-0"

- A.B.E. +30'=ALLOWABLE BLDG HT
243'-6"
- UPPER FLOOR TOP PLATE
234'-0 3/8"
- UPPER FLOOR TOP PLATE
230'-9 3/8"
- MID FLOOR TOP PLATE-LIVING ROOM
228'-5"
- MID FLOOR TOP PLATE
226'-5"
- UPPER FLOOR F.F.L. - 223'-1 3/8"
- GROUND FLOOR TOP PLATE
222'-0 3/8"
- MID FLOOR F.F.L. - 218'-9 1/2"
- BASEMENT FLOOR TOP PLATE
217'-8"
- GROUND FLOOR F.F.L.
214'-3 1/4" A.B.E.
213'-6"
- GARAGE FLOOR F.F.L.
211'-5 3/4"
- BASEMENT FLOOR F.F.L.
210'-0"
- NEW GARAGE AT ELEVATION
OF EXISTING CARPORT

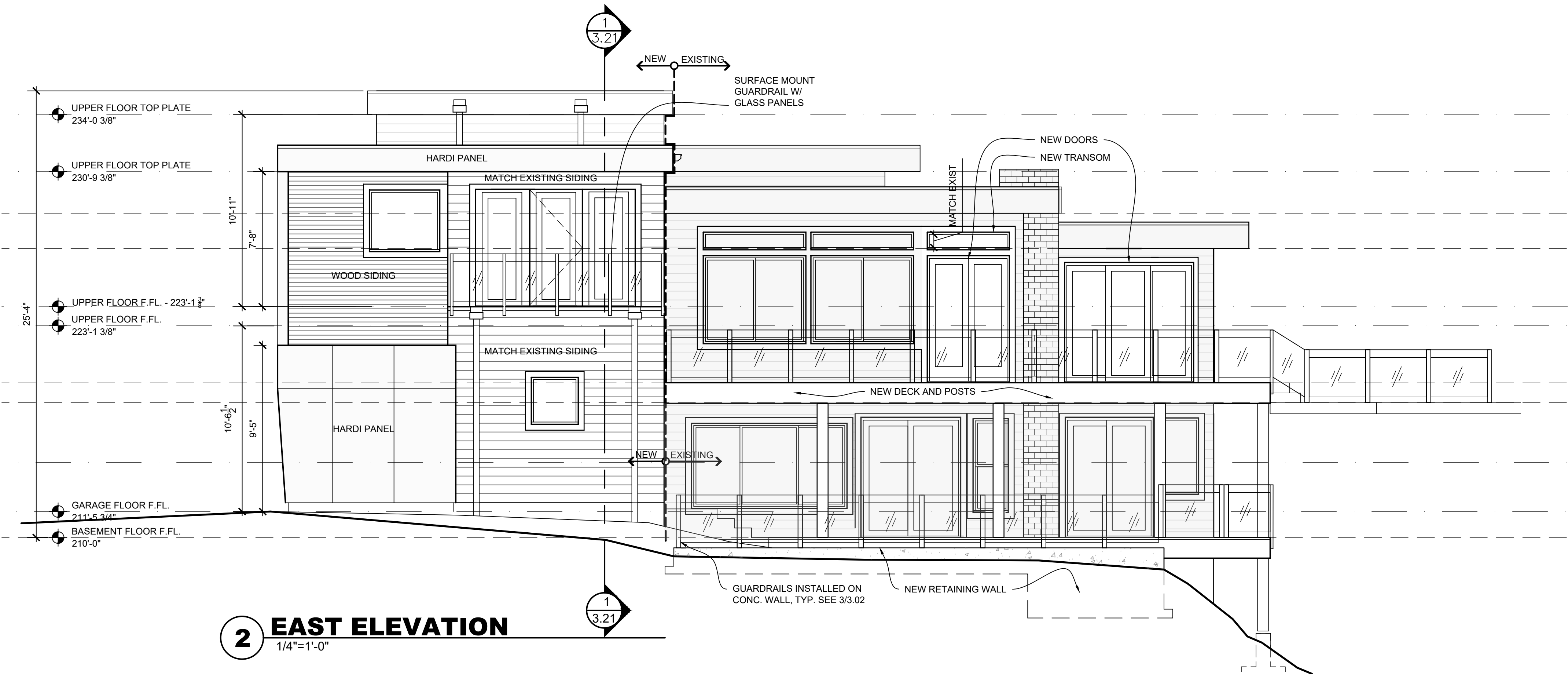

2 EAST ELEVATION
1/4"=1'-0"

- EXTERIOR ELEVATION NOTES:**
(see sheet G0.01 for additional notes)
1. Verify shear wall nailing & holdowns per struct. plan & schedule prior to installing siding.
 2. The building envelope shall be sealed, caulked, gasketed, & weather-stripped to limit air leakage. Provide infiltration control @ window & door frames, and penetrations & openings at walls, floors, and roofs.
 3. Provide galvanized or anodized sheet metal flashing & counter flashing @ all roof penetrations, chimneys, & skylights per IRC Sec. R703.8.
 4. Provide roof covering per IRC Sec. R905.
-install per mfr's. specs.
 5. Provide ext. wall covering per IRC Sec. R703.
-install per mfr's. specs.
 6. Provide continuous parapet drainage & down spouts @ all eaves, typ.
 7. Site shall be graded & hard surfaces sloped, so as to drain surface water away from building.
 8. See sheet G0.02 for window & door schedules.
 9. SG= safety glass, EG= egress



LSA
LIVING SHELTER ARCHITECTS PLLC

472-A FRONT ST. N
ISSAQUAH, WA 98027
(425) 427-8643

© 2018 LSA. All rights reserved.

file
1644
project name

BRENES REMODEL

project address
2675 74th Ave SE
Mercer Island, WA 98040

owner
CHRIS & JEN BRENES
619.957.5849
jenniferbrenes@comcast.net

project manager
ROY MCGARRAH
living shelter architects
425.427.8643
roy@livingshelter.com

survey
C & C SURVEYING, LLC
425.673.7502
ccsurveyllc@gmail.com

structural engineer
SWENSON SAY FAGET
206.443.6212
info@ssfengineers.com

geotechnical engineer
EARTH SOLUTIONS NW
425.284.3300
kevenh@esnw.com

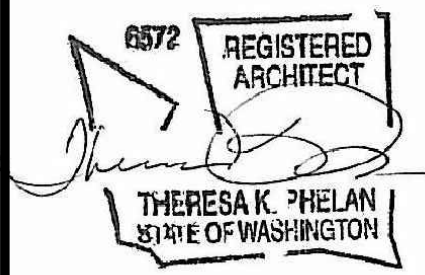

revisions
1 REV: 2/13/20

date
16 JAN 2020

sheet title

ELEVATION

sheet number

A2.11



LSA

LIVING SHELTER ARCHITECTS PLLC

472-A FRONT ST. N
ISSAQUAH, WA 98027
(425) 427-8643

© 2018 LSA. All rights reserved.

file
1644

project name

BRENES REMODEL

project address
2675 74th Ave SE
Mercer Island, WA 98040

owner
CHRIS & JEN BRENES
619.957.5849
jenniferbrenes@comcast.net

project manager
ROY MCGARRAH
living shelter architects
425.427.8643
roy@livingshelter.com

survey
C & C SURVEYING, LLC
425.673.7502
ccsurveyllc@gmail.com

structural engineer
SWENSON SAY FAGET
206.443.6212
info@ssfengineers.com

geotechnical engineer
EARTH SOLUTIONS NW
425.284.3300
kevenh@esnw.com

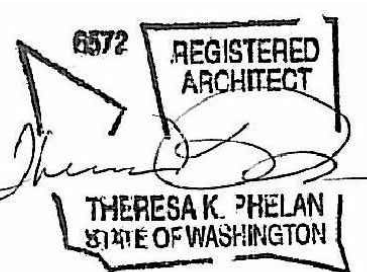

revisions
1 REV: 2/13/20

date
16 JAN 2020

sheet title
ELEVATION

sheet number
A2.12

EXTERIOR ELEVATION NOTES:
(see sheet G0.01 for additional notes)

1. Verify shear wall nailing & holdowns per struct. plan & schedule prior to installing siding.
2. The building envelope shall be sealed, caulked, gasketed, & weather-stripped to limit air leakage. Provide infiltration control @ window & door frames, and penetrations & openings at walls, floors, and roofs.
3. Provide galvanized or anodized sheet metal flashing & counter flashing @ all roof penetrations, chimneys, & skylights per IRC Sec. R703.8.
4. Provide roof covering per IRC Sec. R905.
-install per mfr's. specs.
5. Provide ext. wall covering per IRC Sec. R703.
-install per mfr's. specs.
6. Provide continuous parapet drainage & down spouts @ all eaves, typ.
7. Site shall be graded & hard surfaces sloped, so as to drain surface water away from building.
8. See sheet G0.02 for window & door schedules.
9. SG= safety glass, EG= egress

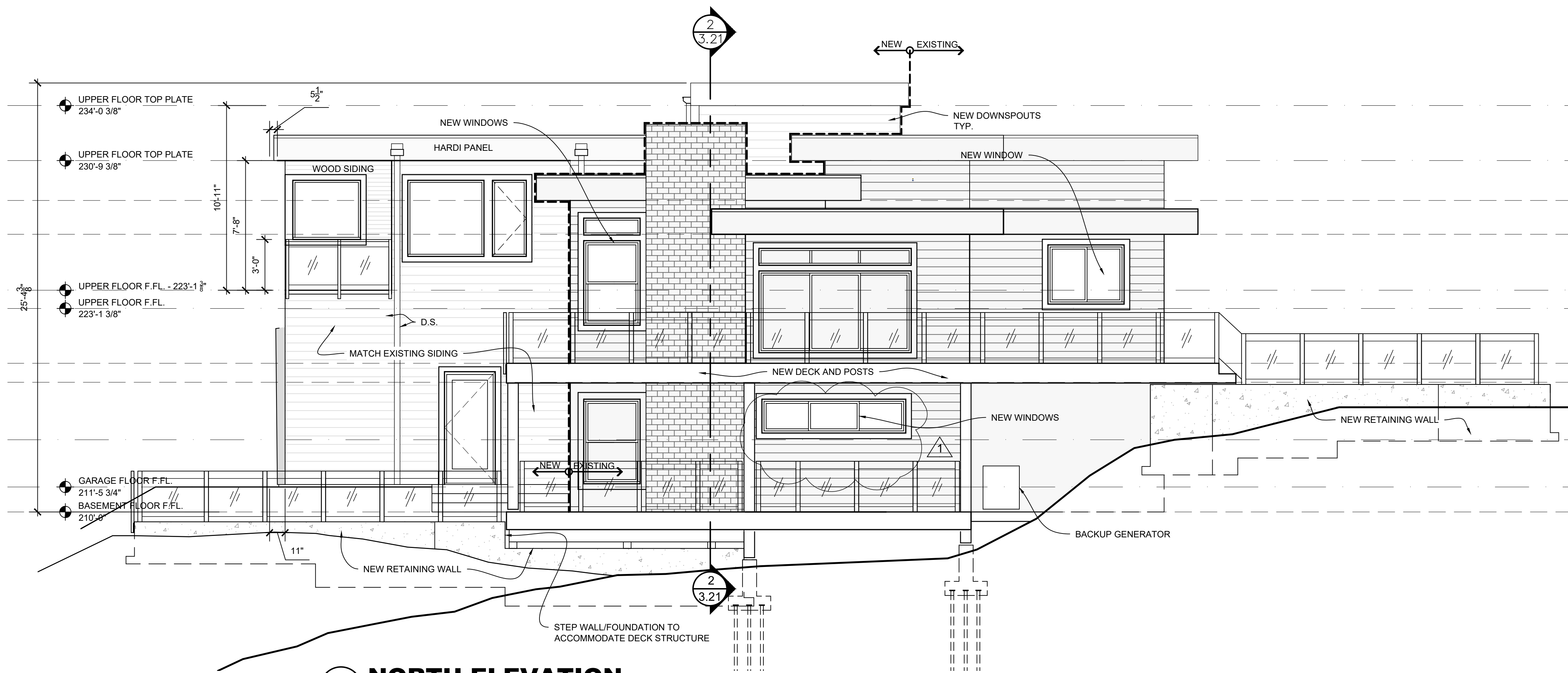

1 NORTH ELEVATION
1/4"=1'-0"

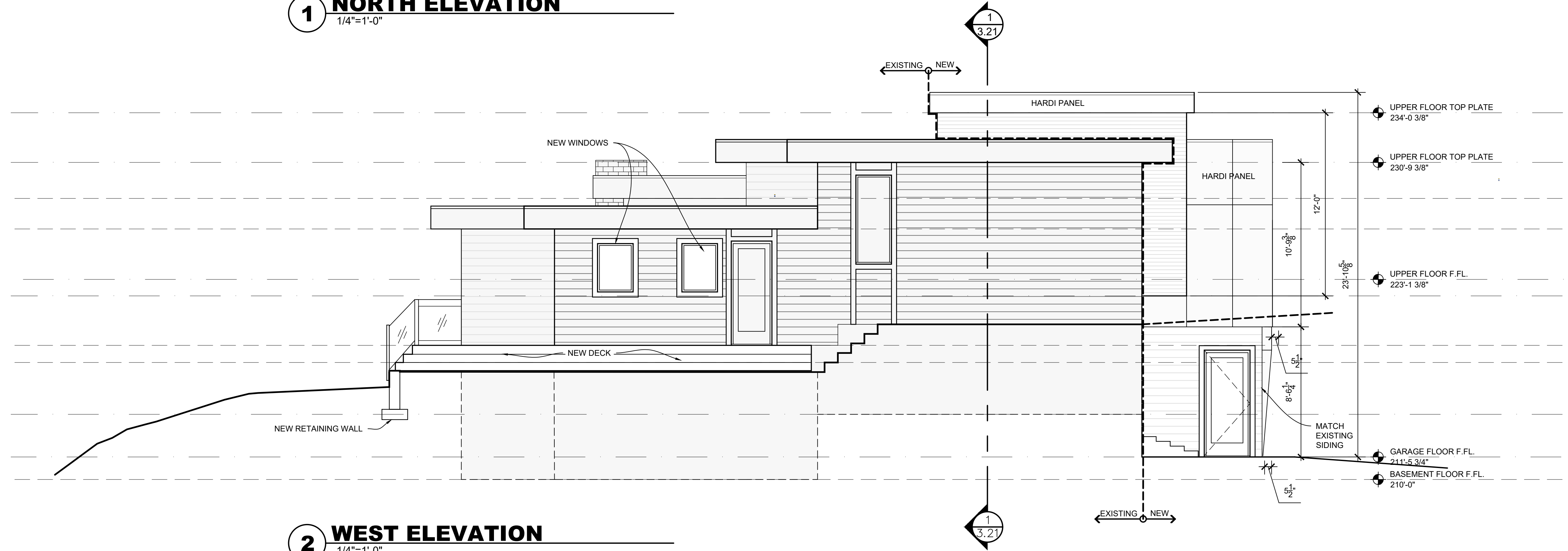

2 WEST ELEVATION
1/4"=1'-0"



LSA

LIVING SHELTER ARCHITECTS PLLC

472-A FRONT ST. N
ISSAQUAH, WA 98027
(425) 427-8643

© 2018 LSA. All rights reserved.

file
1644

project name
BRENES REMODEL

project address
2675 74th Ave SE
Mercer Island, WA 98040

owner
CHRIS & JEN BRENES
619.957.5849
jenniferbrenes@comcast.net

project manager
ROY MCGARRAH
living shelter architects
425.427.8643
roy@livingshelter.com

survey
C & C SURVEYING, LLC
425.673.7502
ccsurveyllc@gmail.com

structural engineer
SWENSON SAY FAGET
206.443.6212
info@ssfengineers.com

geotechnical engineer
EARTH SOLUTIONS NW
425.284.3300
kevenh@esnw.com

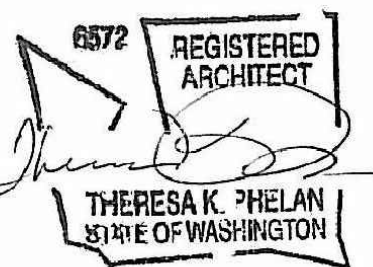

revisions
1 REV: 2/13/20

date
16 JAN 2020

sheet title
BUILDING SECTION

sheet number
A3.01

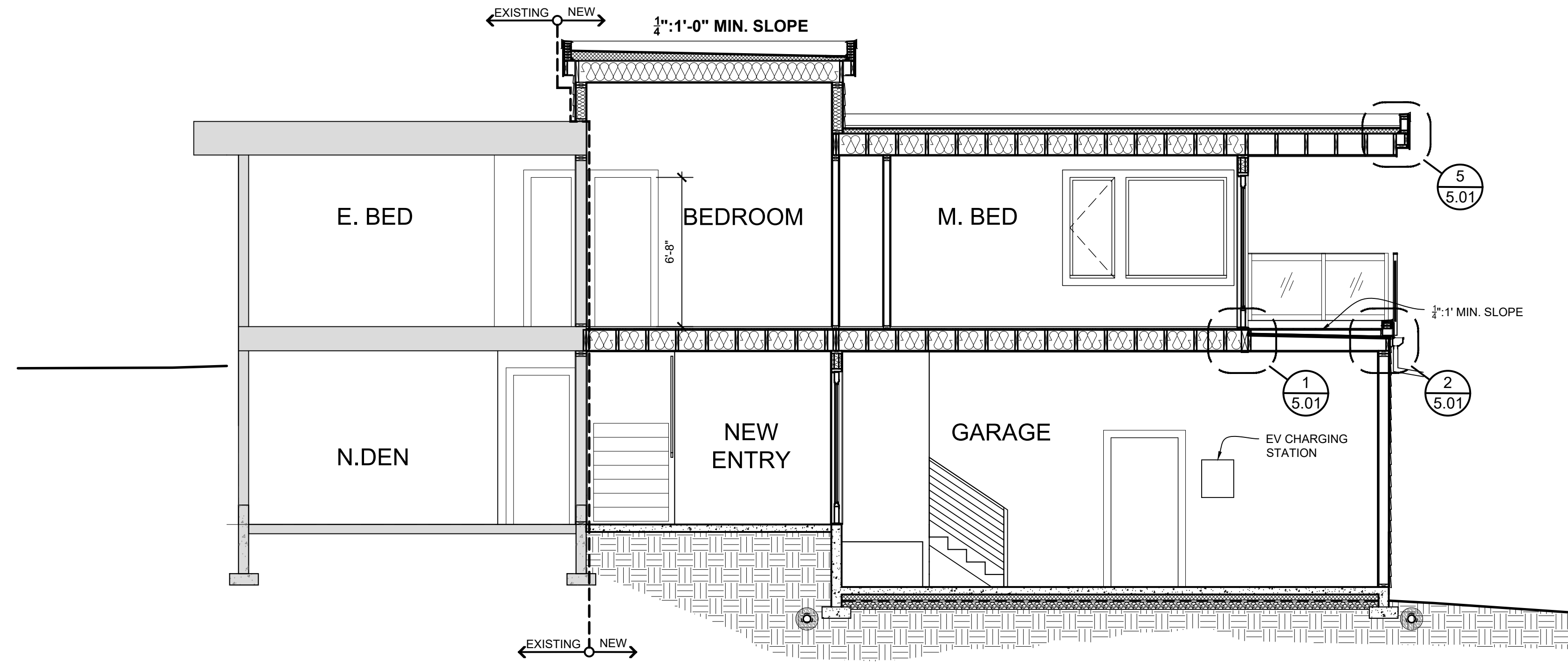

1 BUILDING SECTION
1/4"=1'-0"

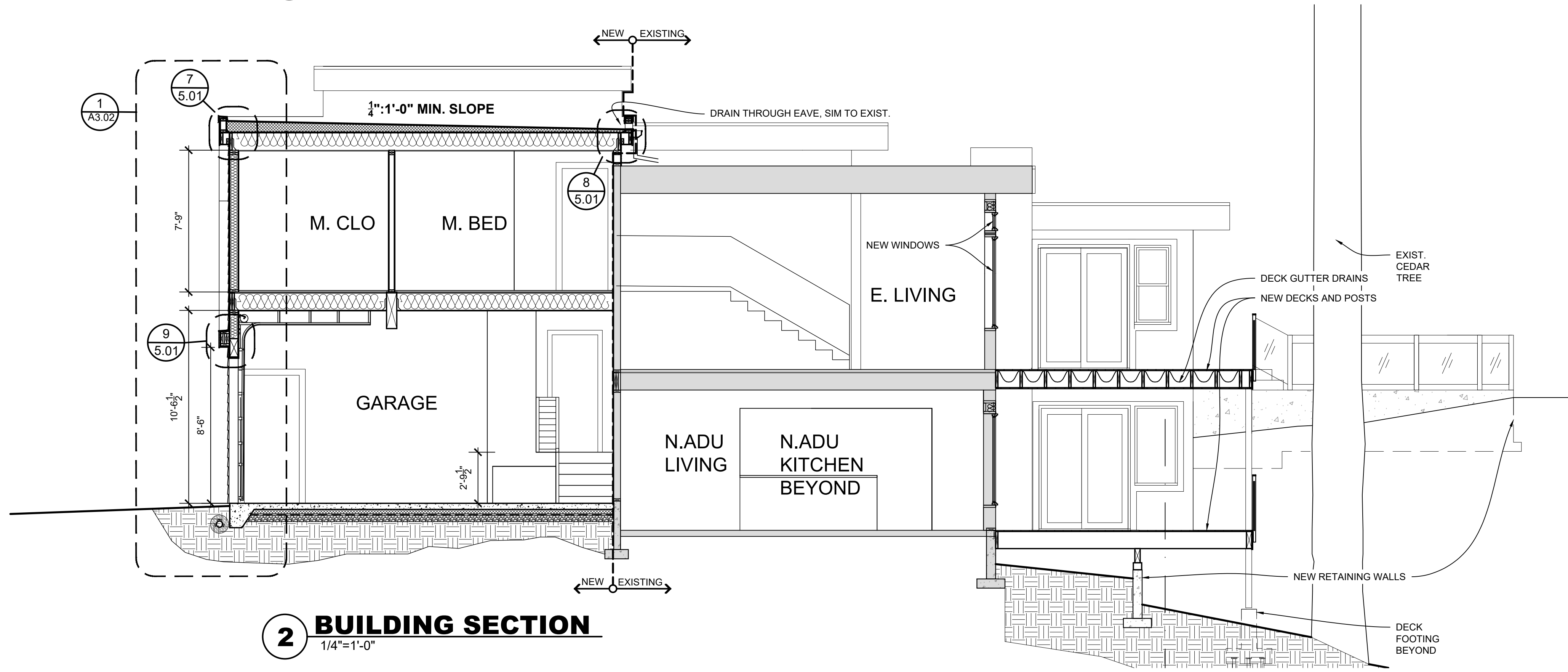

2 BUILDING SECTION
1/4"=1'-0"

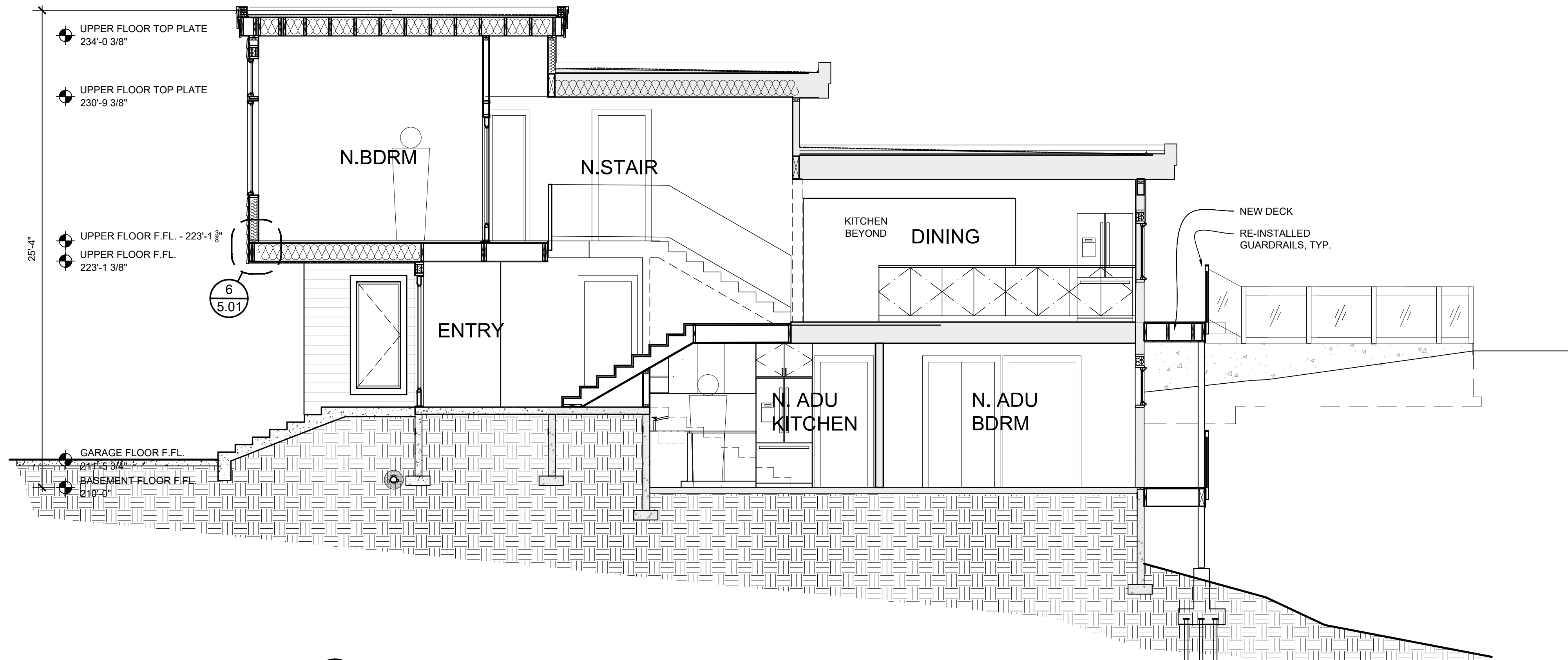

1 PROPOSED ADU STAIR SECTION
1/4"=1'-0"

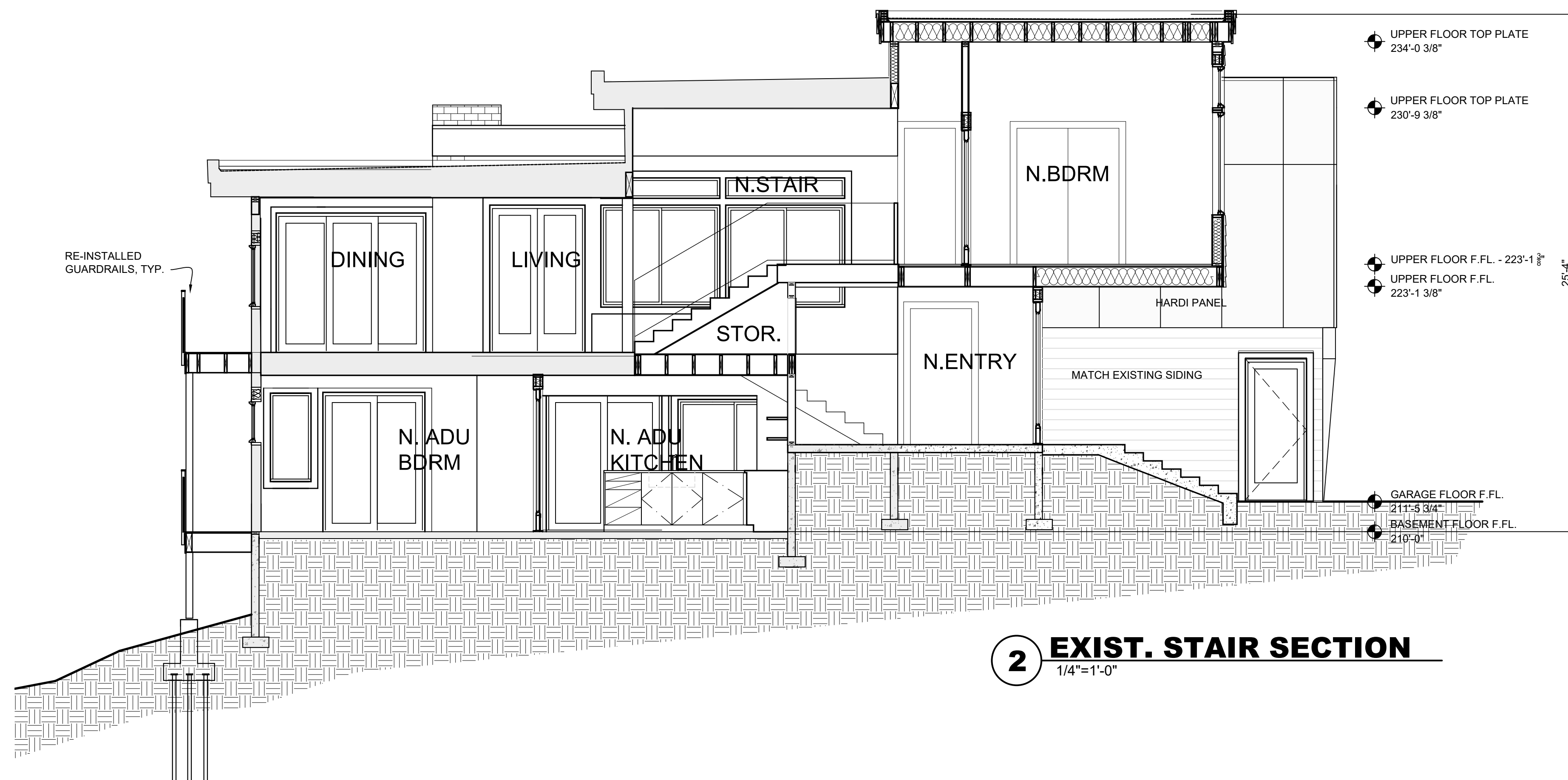

2 EXIST. STAIR SECTION
1/4"=1'-0"



LSA

LIVING SHELTER ARCHITECTS PLLC

472-A FRONT ST. N
ISSAQUAH, WA 98027
(425) 427-8643

© 2018 LSA. All rights reserved.

file **1644**
project name

BRENES REMODEL

project address
2675 74th Ave SE
Mercer Island, WA 98040

owner
CHRIS & JEN BRENES
619.957.5849
jenniferbrenes@comcast.net

project manager
ROY MCGARRAH
living shelter architects
425.427.8643
roy@livingshelter.com

survey
C & C SURVEYING, LLC
425.673.7502
ccsurveyllc@gmail.com

structural engineer
SWENSON SAY FAGET
206.443.6212
info@ssfengineers.com

geotechnical engineer
EARTH SOLUTIONS NW
425.284.3300
kevenh@esnw.com

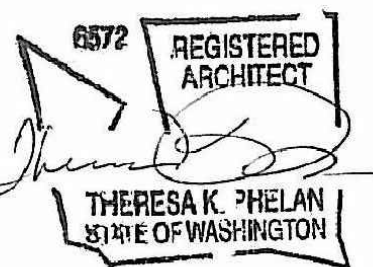

revisions
1 REV: 2/13/20

date **16 JAN 2020**

sheet title
BUILDING SECTION

sheet number
A3.02



LSA

LIVING SHELTER ARCHITECTS PLLC

472-A FRONT ST. N
ISSAQUAH, WA 98027
(425) 427-8643

© 2018 LSA. All rights reserved.

file **1644**

project name
BRENES REMODEL

project address
2675 74th Ave SE
Mercer Island, WA 98040

owner
CHRIS & JEN BRENES
619.957.5849
jenniferbrenes@comcast.net

project manager
ROY MCGARRAH
living shelter architects
425.427.8643
roy@livingshelter.com

survey
C & C SURVEYING, LLC
425.673.7502
ccsurveyllc@gmail.com

structural engineer
SWENSON SAY FAGET
206.443.6212
info@ssfengineers.com

geotechnical engineer
EARTH SOLUTIONS NW
425.284.3300
kevenh@esnw.com



revisions
1 REV: 2/13/20

date
16 JAN 2020

sheet title
WALL SECTION

sheet number
A3.03

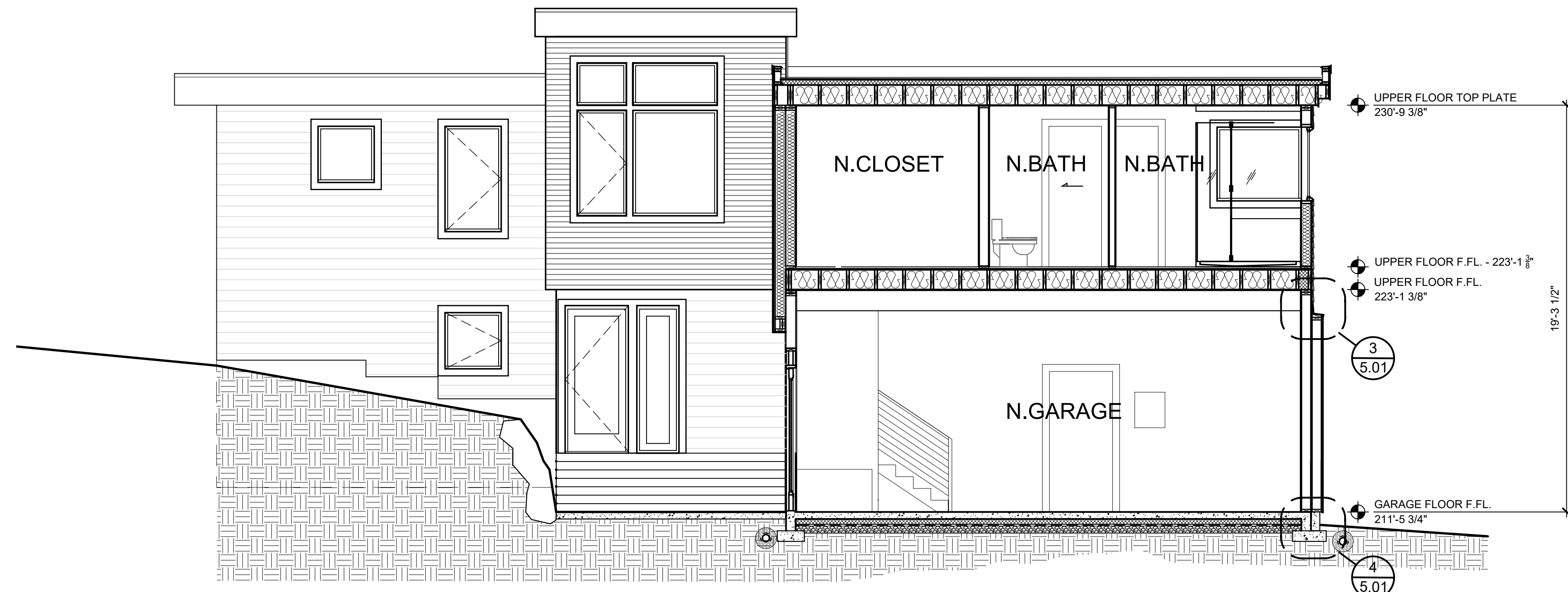

SECTION

2 BUILDING SECTION
1/4"=1'-0"

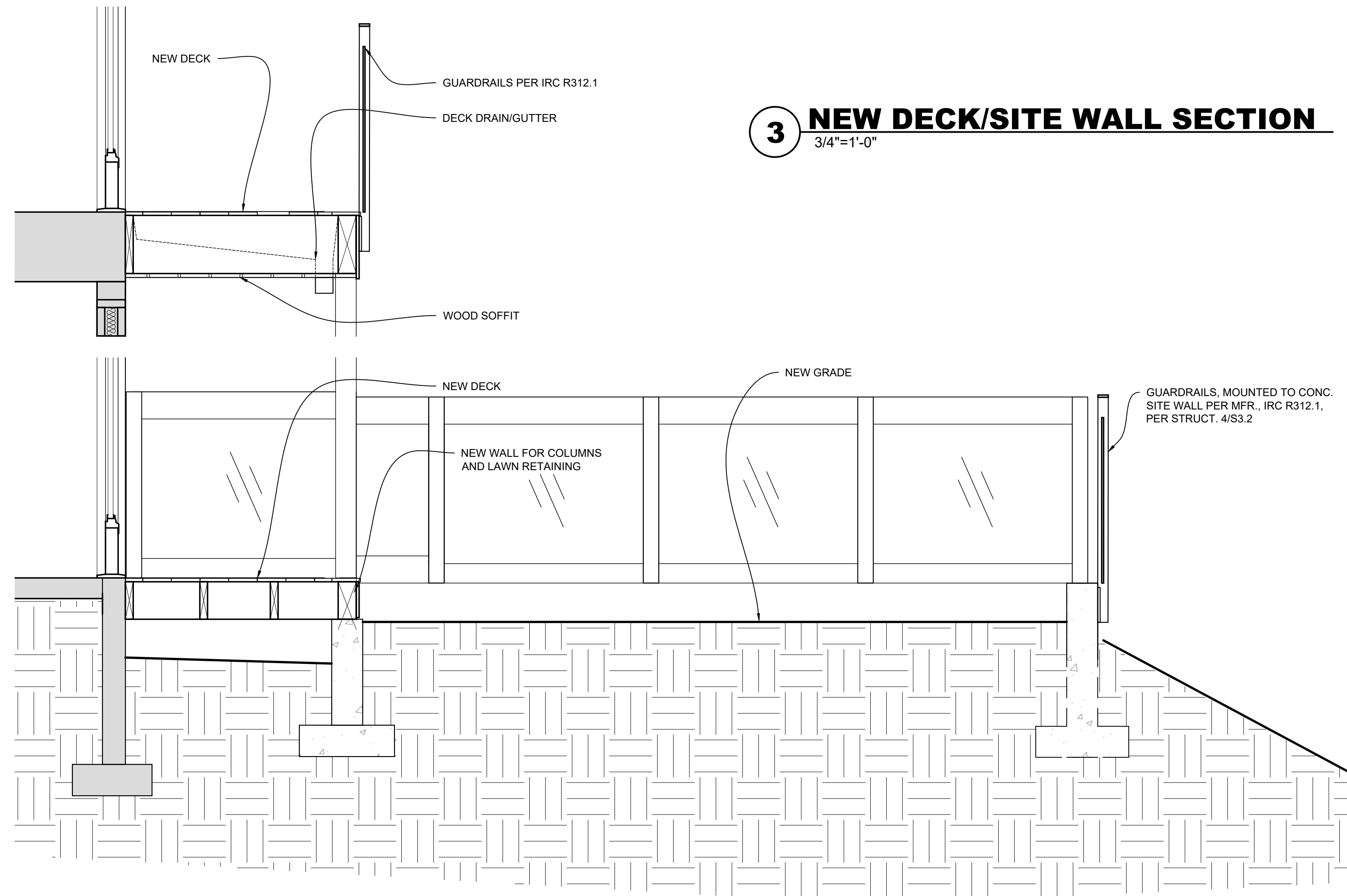

3 NEW DECK/SITE WALL SECTION
3/4"=1'-0"

***UN-VENTED ROOF ASSEMBLY PER IRC R806.5**

TYPICAL ROOF CONSTRUCTION:

- ROOF MEMBRANE TO MATCH EXIST. OR SIM.
- INSULATION PROTECTION BOARD
- PRE-MANUF. SLOPED RIGID INSUL. 1/4" : 1" MIN. R-10 MIN. PER R806.5
- CONTINUOUS AIR BARRIER
- SHTG PER STRUCT.
- RAFTERS PER STRUCT.
- R-38 MIN. BATT INSULATION, TIGHT TO SHEATHING PER R806.5.1.2
- 1/2" GWB CEILING

BUMP OUT WALL CONSTRUCTION:

- OCQUIRES AT M.C.L. W. WALL + GARAGE E. WALL
- SIDING PER ELEVATIONS
- WATER RESISTIVE MEMBRANE
- 1/2" SHTG PER STRUCTURAL
- 2X6 STUDS @ 16" O.C.
- R-21 BATT INSULATION
- PLYWOOD SHTG PER STRUCT.
- 2X6 STUDS @ 16" O.C.
- R-21 BATT INSULATION
- 3/4" GWB INTERIOR SHTG

TYPICAL FLOOR CONSTRUCTION:

- FINISH FLOOR PER FINISH SCHEDULE
- SHTG PER STRUCT.
- FRAMING PER STRUCT.
- FILL CAVITY WITH BATT INSULATION
- 5/8" GWB

TYPICAL FLOOR CONSTRUCTION - ABOVE GARAGE

- FINISH FLOOR PER FINISH SCHEDULE
- SHTG PER PLAN
- FRAMING PER PLAN
- R-30 BATT INSUL.
- 3/8" TYPE X GWB CEILING

TYPICAL WALL CONSTRUCTION:

- SIDING PER ELEVATIONS
- WATER RESISTIVE MEMBRANE
- SHTG PER STRUCT
- 2X6 STUDS @ 16" O.C.
- R-21 MIN. "ROXUL COMFORT BATT" INSULATION
- 3/4" GWB INTERIOR SHTG (TYPE X AT EXIST. WALLS)

TYPICAL FOUNDATION CONSTRUCTION:

- FINISHED FLOOR PER PLAN
- 4" CONC. SLAB PER STRUCT. (1/4":1'-0" GARAGE SLOPE)
- RIGID INSULATION R-10 MINIMUM
- 6 MIL VAPOR BARRIER
- 4" GRAVEL

- 12" MIN. OR FROST DEPTH.

- 4" PERFORATED FTG. DRAIN BED IN WASHED GRAVEL WRAP W/ FILTER FABRIC

1 WALL SECTION
1/2"=1'-0"

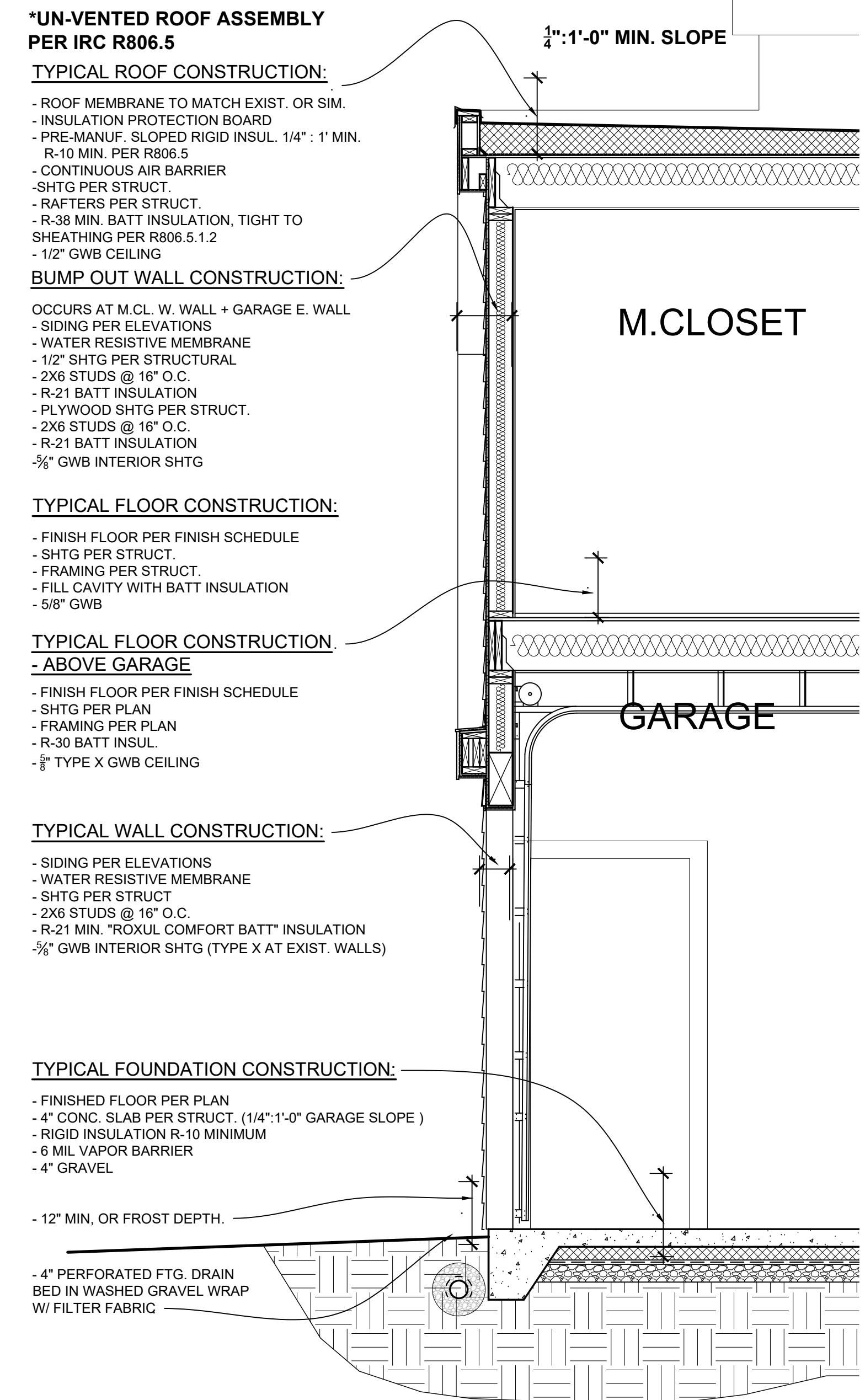



LSA

LIVING SHELTER ARCHITECTS PLLC

472-A FRONT ST. N
ISSAQUAH, WA 98027
(425) 427-8643

© 2018 LSA. All rights reserved.

file

1644

project name

BRENES REMODEL

project address
2675 74th Ave SE
Mercer Island, WA 98040

owner

CHRIS & JEN BRENES

619.957.5849

jenniferbrenes@comcast.net

project manager

ROY MCGARRAH

living shelter architects

425.427.8643

roy@livingshelter.com

survey

C & C SURVEYING, LLC

425.673.7502

ccsurveyllc@gmail.com

structural engineer

SWENSON SAY FAGET

206.443.6212

info@ssfengineers.com

geotechnical engineer

EARTH SOLUTIONS NW

425.284.3300

kevenh@esnw.com

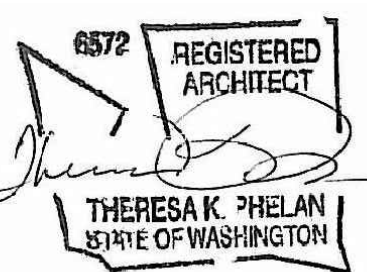

revisions

REV: 2/13/20

date

16 JAN 2020

sheet title

WATER PROOFING DETAILS

sheet number

A5.03

INSTALLATION STEPS:

- CUT AND FOLD SELF-ADHESIVE FLEXIBLE SILL FLASHING INTO FRAME OPENING; LEAVE BOTTOM EDGE OF SILL FLASHING UNATTACHED.
- CUT AND FOLD SELF-ADHESIVE FLEXIBLE CORNER FLASHING INTO BOTH BOTTOM CORNERS OF FRAME OPENING CUT AND FOLD SELF ADHESIVE FLEXIBLE FLASHING INTO JAMB
- FRAME OPENING; LEAVE BOTTOM EDGES OF JAMB FLASHING UNATTACHED CUT AND FOLD SELF ADHESIVE FLEXIBLE FLASHING INTO HEAD
- FRAME OPENING; SEAL WINDOW FRAME TO OPENING. APPLY CONT. BEAD OF
- SEALANT WITHIN 1/2" OF EDGE OF OPENING OR APPLY CONT. SEALANT ON BACKSIDE OF WINDOW FLANGES @ HEAD, JAMB & SILL; THEN INSTALL FRAME TO OPENING. **CHECK WINDOW FINIS FOR DAMAGE. REPAIR OR REPLACE DAMAGED FINIS.** **FASTENERS TO BE STAINLESS STEEL ROOFING NAILS (1 1/2") OR EQUAL. MINIMUM PENETRATION INTO FRAMING TO BE 1" ** **GALVANIZED FASTENERS ALLOWED WHEN INSTALLING VINYL WINDOWS** WHEN INSTALLING A WINDOW: NAIL BOTTOM CORNER FIRST.
- SET WINDOW STRAIGHT, PLUMB & LEVEL BEFORE SECURING. PROVIDE CONTINUOUS SUPPORT OR SHIMS UNDER FRAME OF SILL IF REQUIRED BY MFR. FASTEN THROUGH SIDES OF FRAME. DO NOT FASTEN THROUGH HEAD UNLESS PERMITTED BY WINDOW MFR.
- INSTALL BUILDING PAPER FROM THE BOTTOM TO TOP OF THE WALL SHINGLE EACH COARSE TO FACILITATE PROPER DRAINAGE.

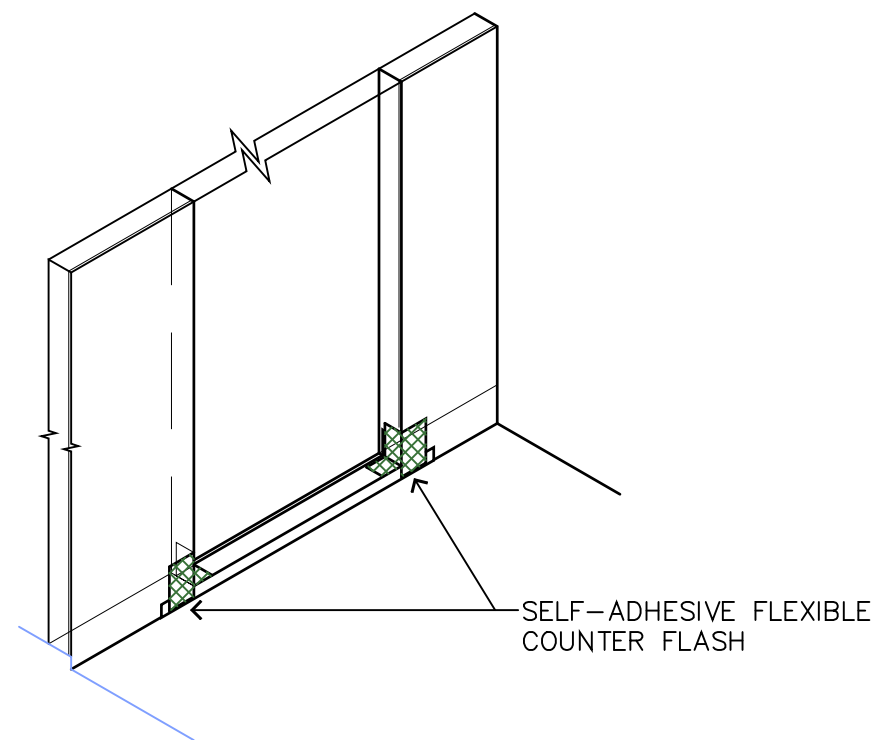
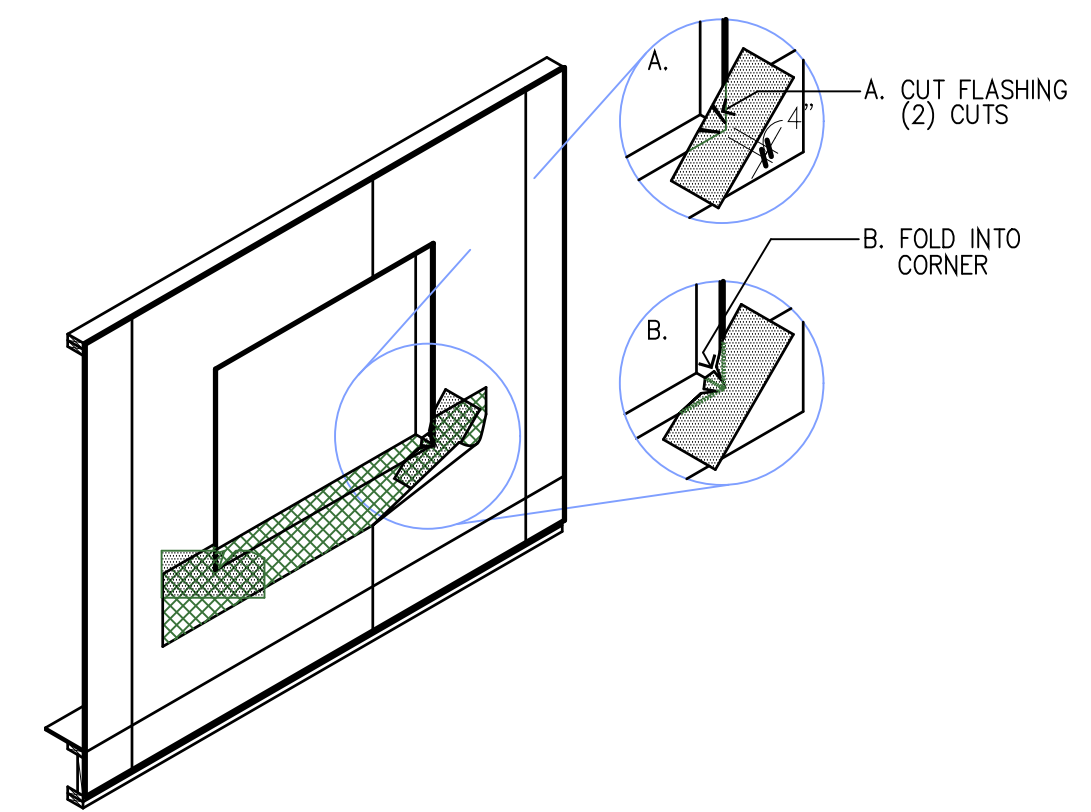
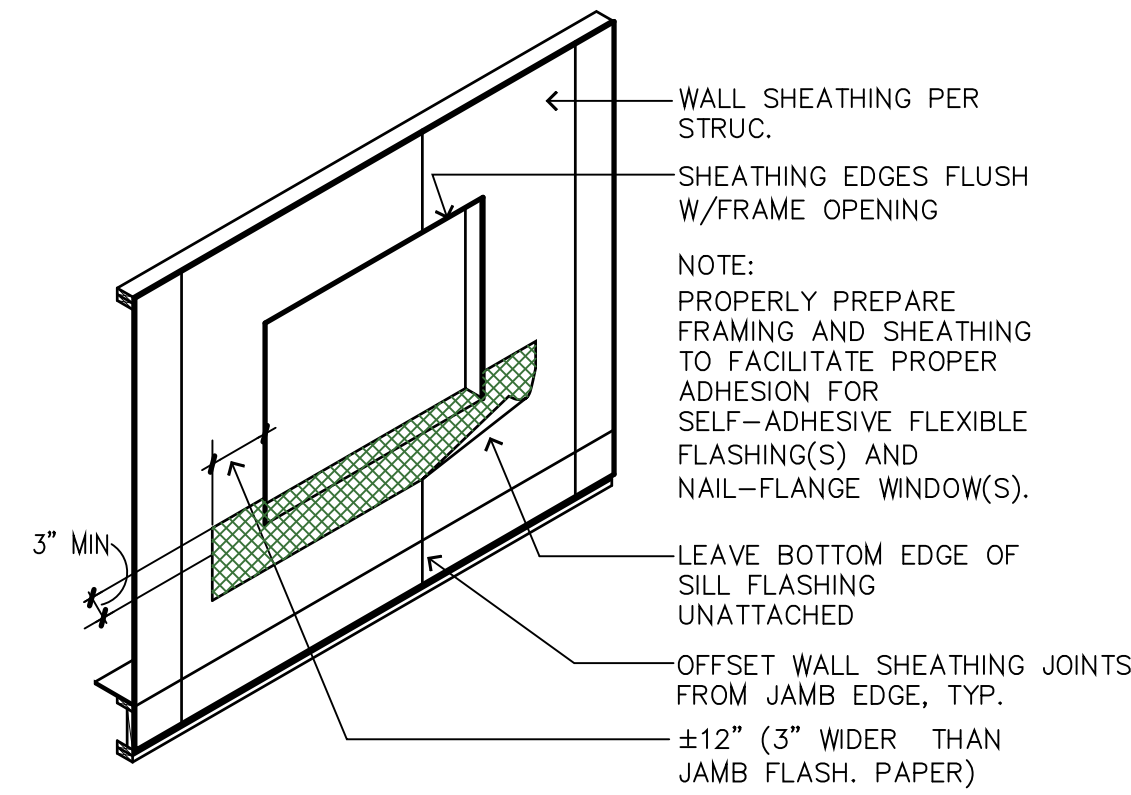
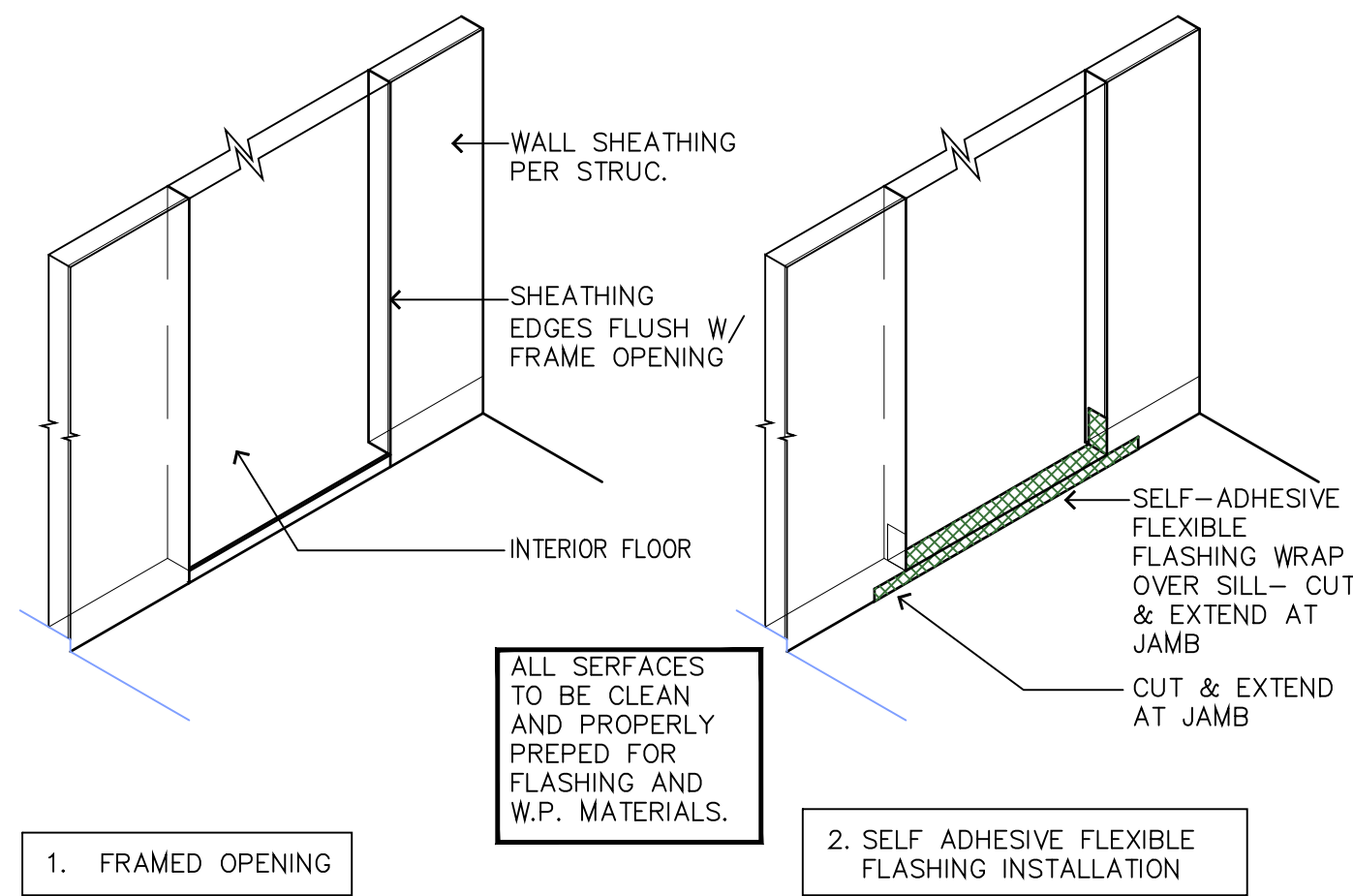

JAMB MUST ACCOMODATE THICKNESS OF ALL FLASHING MATERIAL- VERIFY W/ MANUFR.

VERIFY DOOR INSTALLATION REQUIREMENTS WITH DOOR MANUFACTURER

COORDINATE PAN FLASHING WITH EXT. W.P. MEMBRANE

NOTE: INSTALL DOOR PER TYPICAL FLASHING AND WINDOW/DOOR INSTALLATION DETAIL

3. SELF ADHESIVE FLEXIBLE COUNTER FLASHING

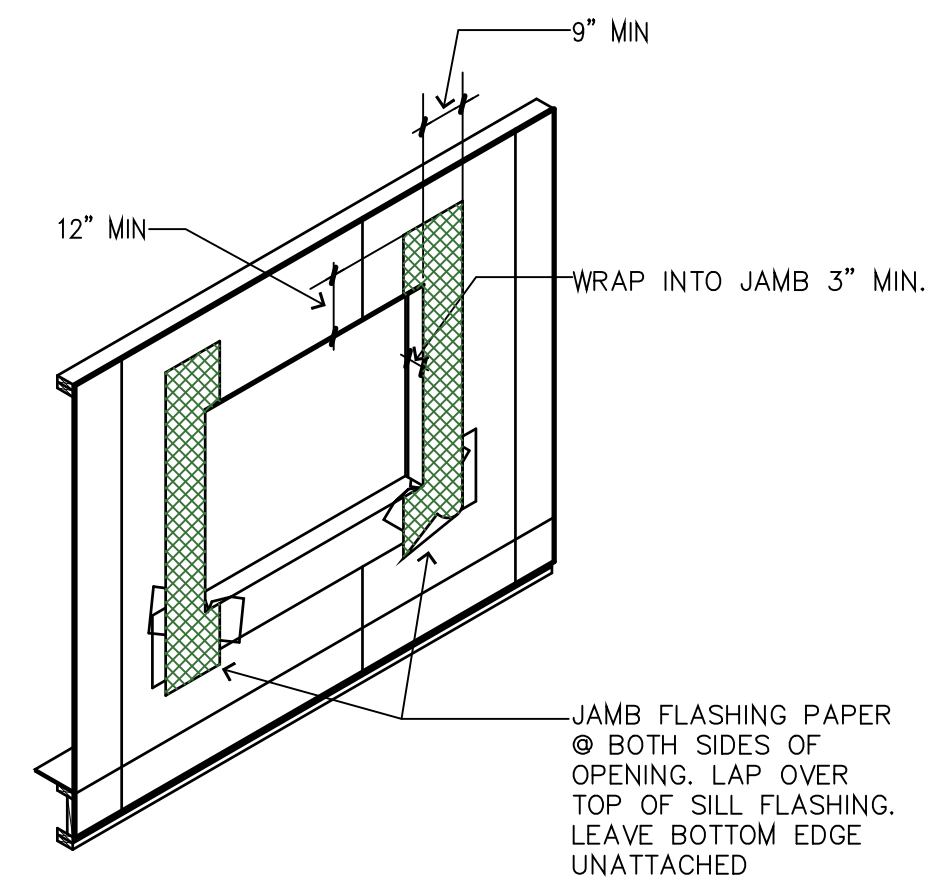

3. MEMBRANE JAMB FLASHING

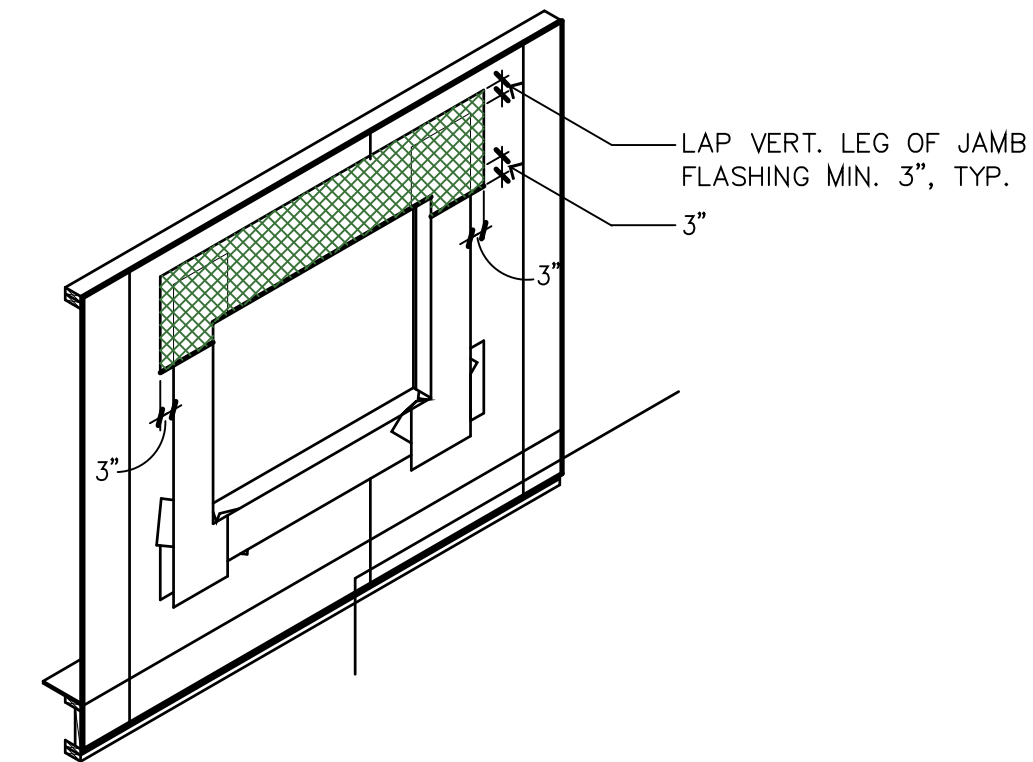

4. MEMBRANE HEAD FLASHING

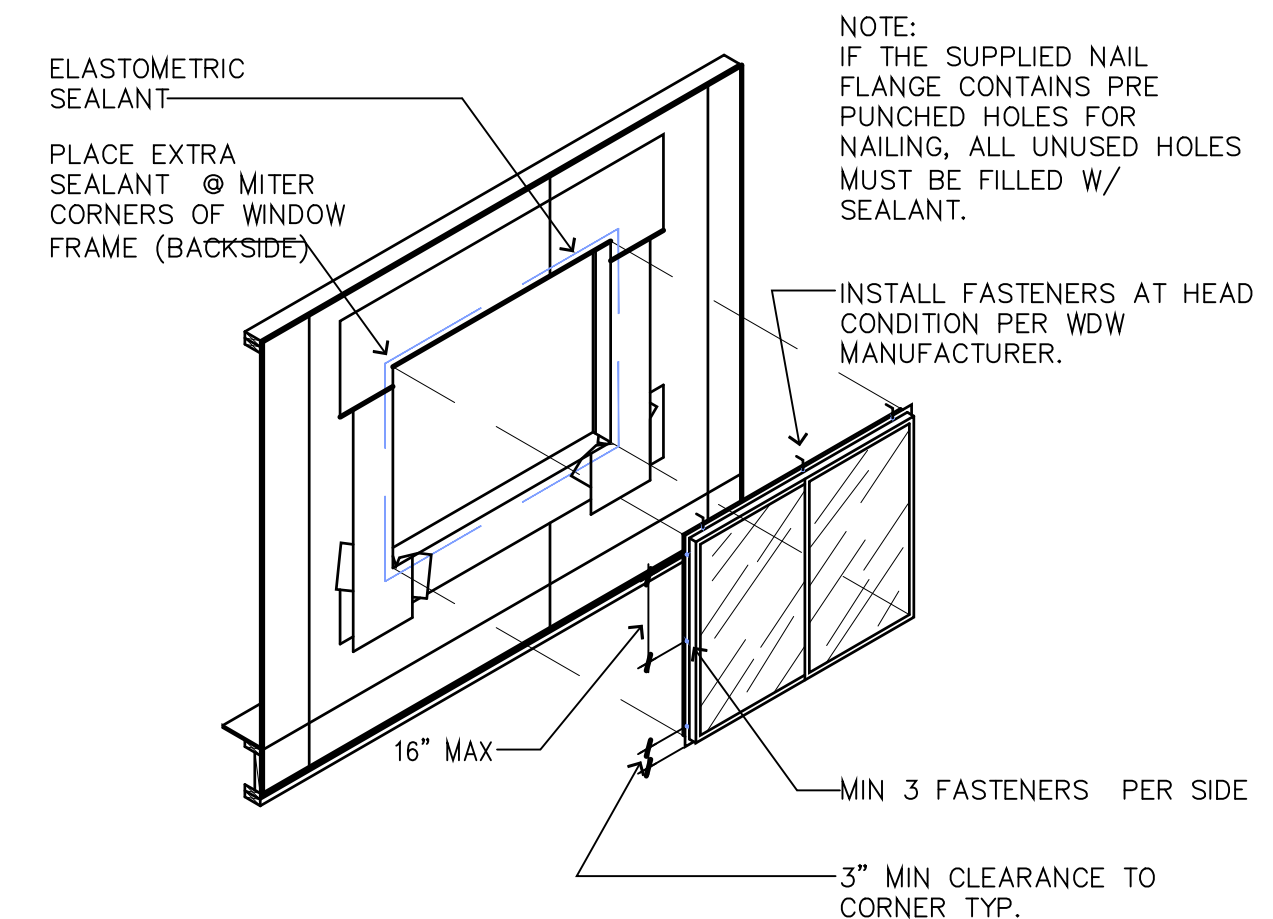

5. WINDOW INSTALATION

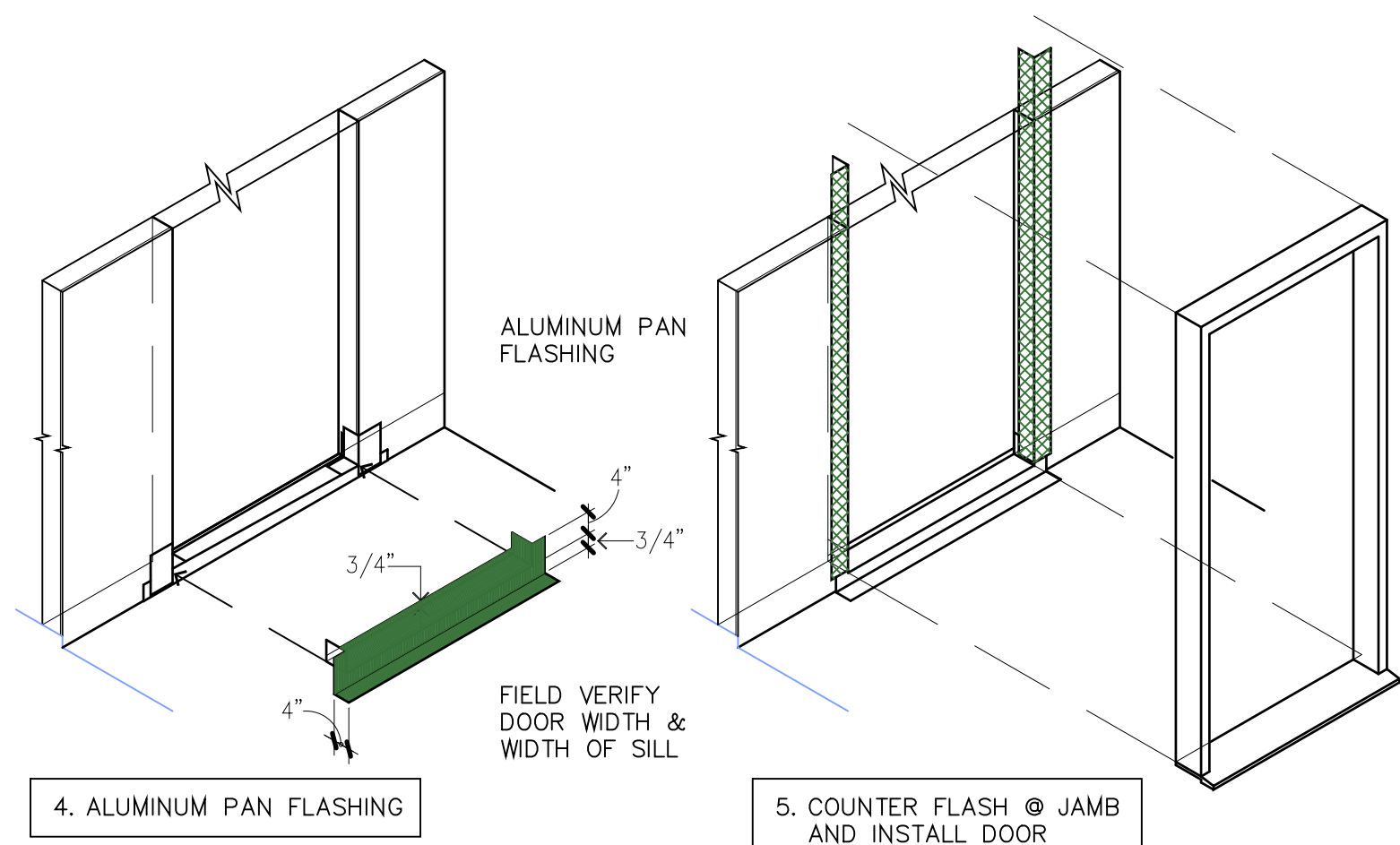

DOOR PAN
NO SCALE

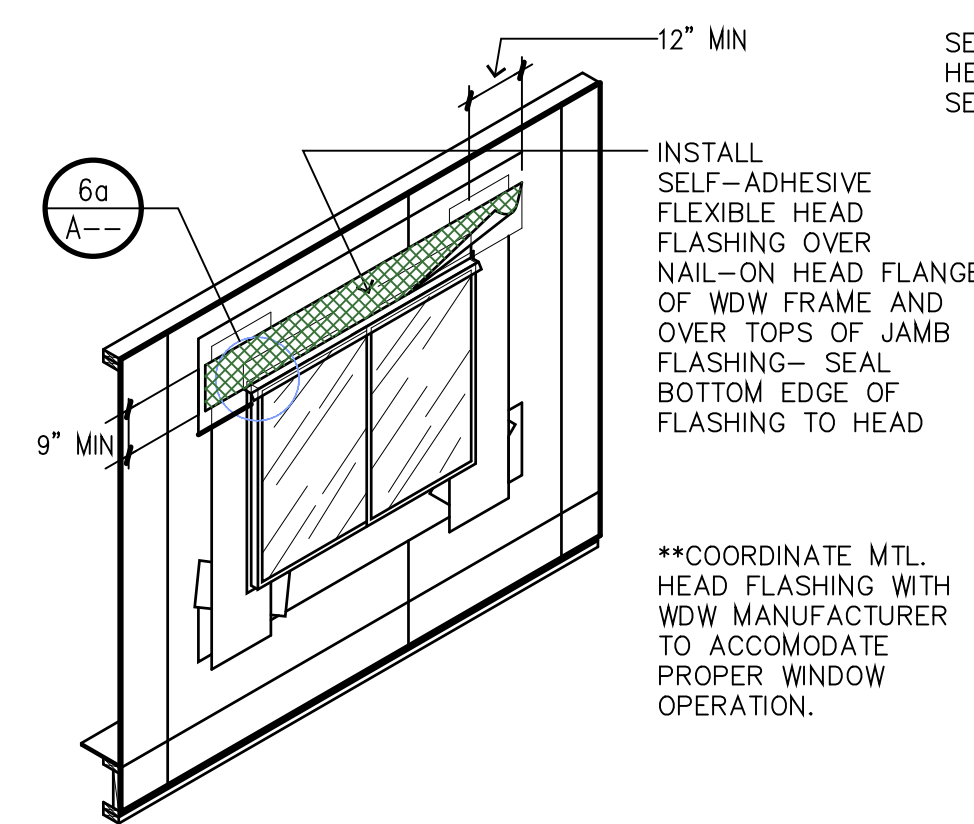

6. HEAD FLASHING SEQUENCE

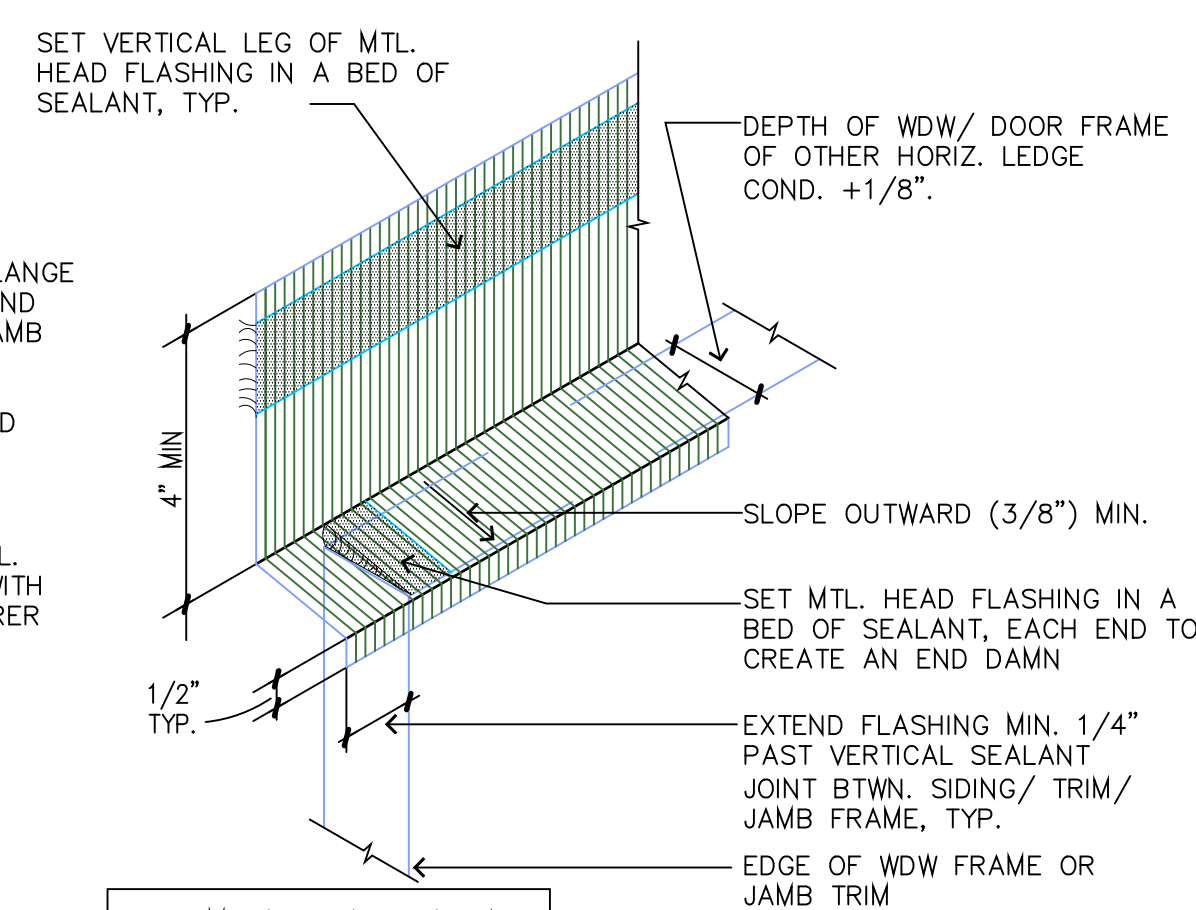

6a. METAL HEAD FLASHING

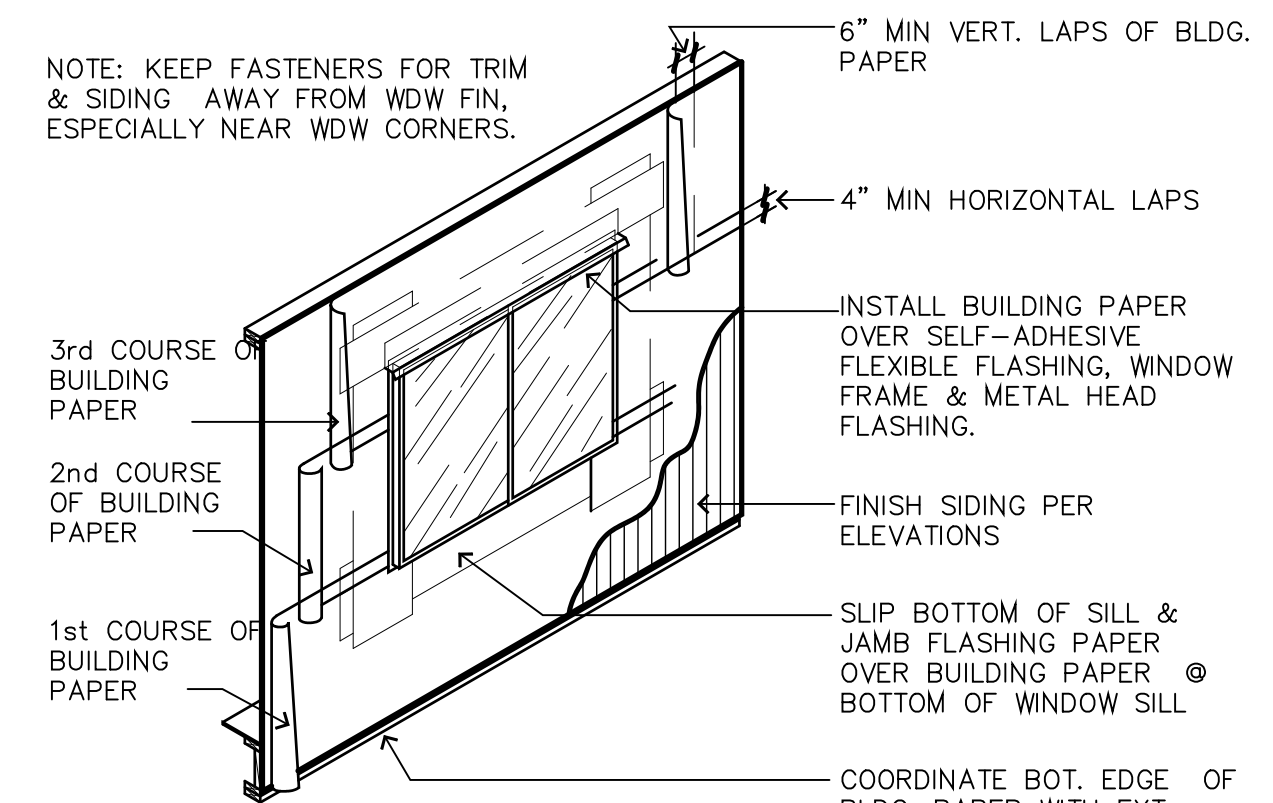

8. BUILDING PAPER APPLICATION

FLASHING AND NAIL FLANGE WINDOW INSTALLATION

NO SCALE

A5.03

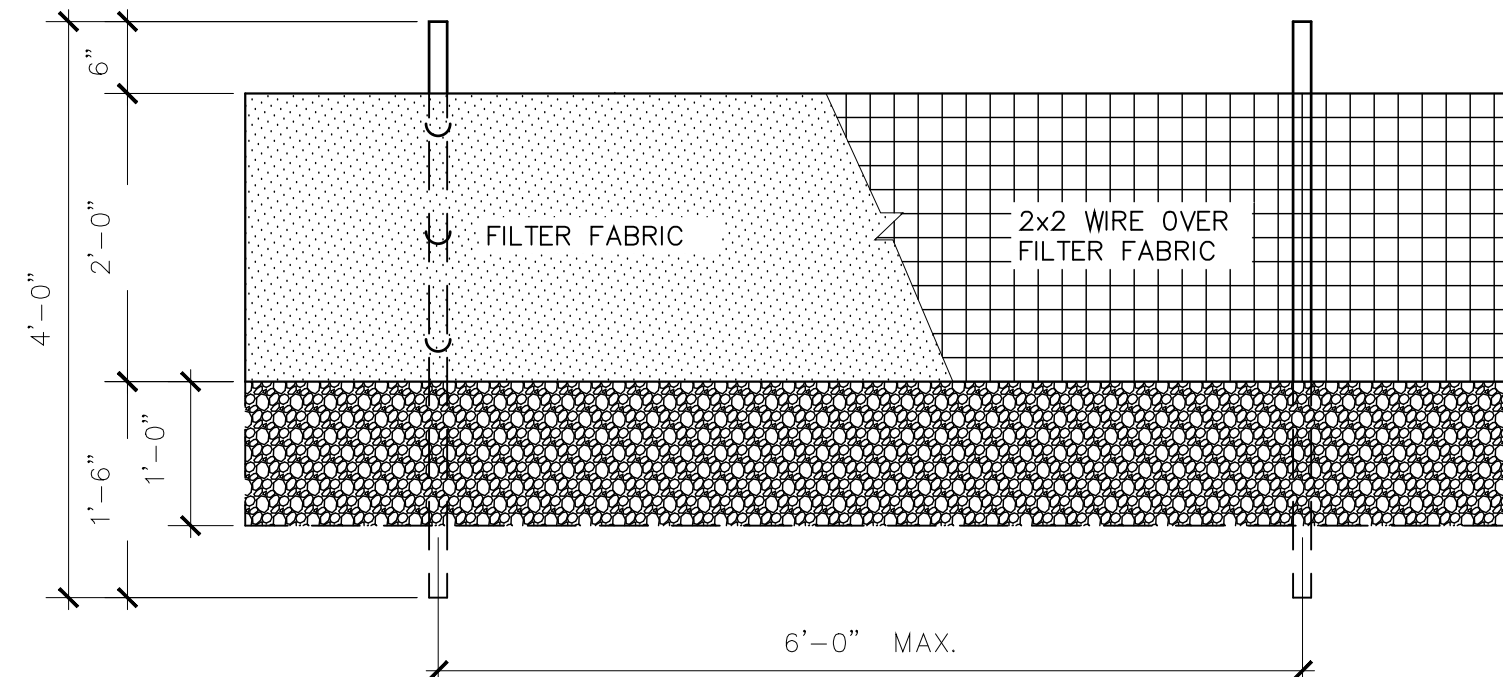

GEOTEXTILE FILTER FABRIC: BURY BOTTOM OF FILTER FABRIC @ TRENCH.

2"x2"x#14 GA. WIRE OR EQUIVALENT, IF STANDARD STRENGTH FABRIC USED. FASTEN SECURELY TO UPHILL SIDE OF POSTS.

MINIMUM 8"x12" TRENCH BACKFILL TRENCH WITH 3/4"-1 1/2" WASHED GRAVEL.

MIN. 2"x2" STD. OR BETTER WOOD POSTS, STEEL FENCE POSTS, OR EQUIVALENT. SPACE @ 6'-0" O.C. MAX.

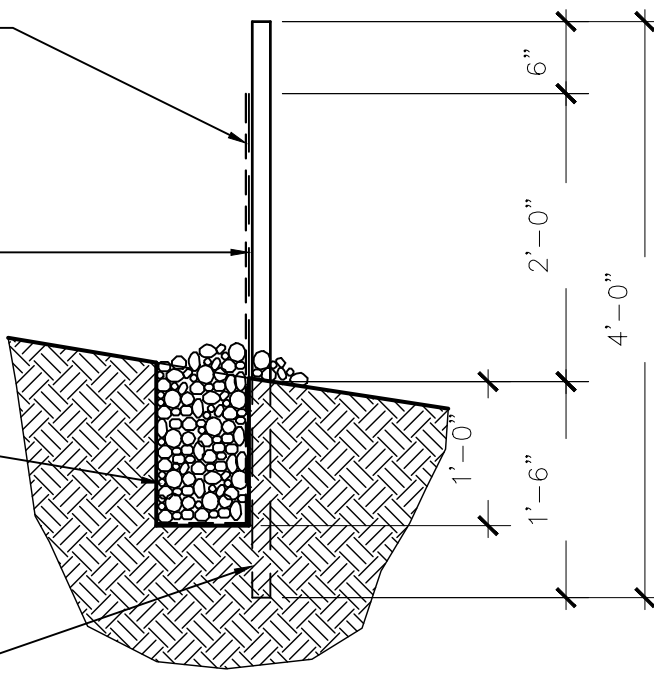

TEMPORARY EROSION AND SEDIMENT CONTROL (TESC) NOTES:

1. THE IMPLEMENTATION OF TESC MEASURES AND THE CONSTRUCTION, MAINTENANCE, REPLACEMENT AND UPGRADING OF TESC FACILITIES IS THE RESPONSIBILITY OF THE CONTRACTOR UNTIL ALL CONSTRUCTION IS APPROVED.
2. THE TESC FACILITIES SHOWN ON THIS PLAN MUST BE CONSTRUCTED IN CONJUNCTION WITH ALL CLEARING AND GRADING ACTIVITIES AND IN SUCH A MANNER AS TO ENSURE THAT SEDIMENT-LADEN WATER DOES NOT LEAVE THE SITE, ENTER THE DRAINAGE SYSTEM OR VIOLATE APPLICABLE WATER STANDARDS.
3. THE TESC FACILITIES SHOWN ON THIS PLAN ARE THE MINIMUM REQUIREMENTS FOR ANTICIPATED SITE CONDITIONS. DURING THE CONSTRUCTION PERIOD, THESE TESC FACILITIES SHALL BE UPGRADED (E.G. ADDITIONAL SILT FENCES, ETC.) AS NEEDED FOR UNEXPECTED STORM EVENTS.
4. ALL TESC FACILITIES SHALL CONFORM TO ALL APPLICABLE STATE AND CITY REQUIREMENTS.

NOTE: FILTER FABRIC FENCES SHALL BE INSTALLED ALONG CONTOUR WHENEVER POSSIBLE.

MAINTENANCE STANDARDS:

1. INSPECT IMMEDIATELY AFTER EACH RAINFALL, ANY DAMAGE SHALL BE REPAIRED IMMEDIATELY.
2. IF CONCENTRATED FLOWS ARE EVIDENT UPHILL OF THE FENCE, THEY MUST BE INTERCEPTED AND CONVEYED TO A SEDIMENT TRAP OR POND.
3. IT IS IMPORTANT TO CHECK THE UPHILL SIDE OF THE FENCE FOR SIGNS OF THE FENCE CLOGGING AND ACTING AS A BARRIER TO FLOW AND THEN CAUSING CHANNELIZATION OF FLOWS PARALLELED TO THE FENCE. IF THIS OCCURS, REPLACE THE FENCE AND/OR REMOVE TRAPPED SEDIMENT.
4. SEDIMENT MUST BE REMOVED WHEN THE SEDIMENT IS 6" HIGH.
5. IF THE FILTER FABRIC HAS DETERIORATED DUE TO ULTRAVIOLET BREAKDOWN, IT SHALL BE REPLACED.
6. ALL TEMPORARY EROSION & SEDIMENT CONTROL MEASURES SHALL BE REMOVED WITHIN 30 DAYS AFTER FINAL SITE STABILIZATION IS ACHIEVED. TRAPPED SEDIMENT SHALL BE REMOVED OR STABILIZED ON SITE.
7. ANY SEDIMENT DEPOSITS REMAINING IN PLACE AFTER THE FENCE IS NO LONGER REQUIRED SHALL BE SPREAD TO CONFORM TO THE EXISTING GRADE, PREPARED, AND SEEDED.

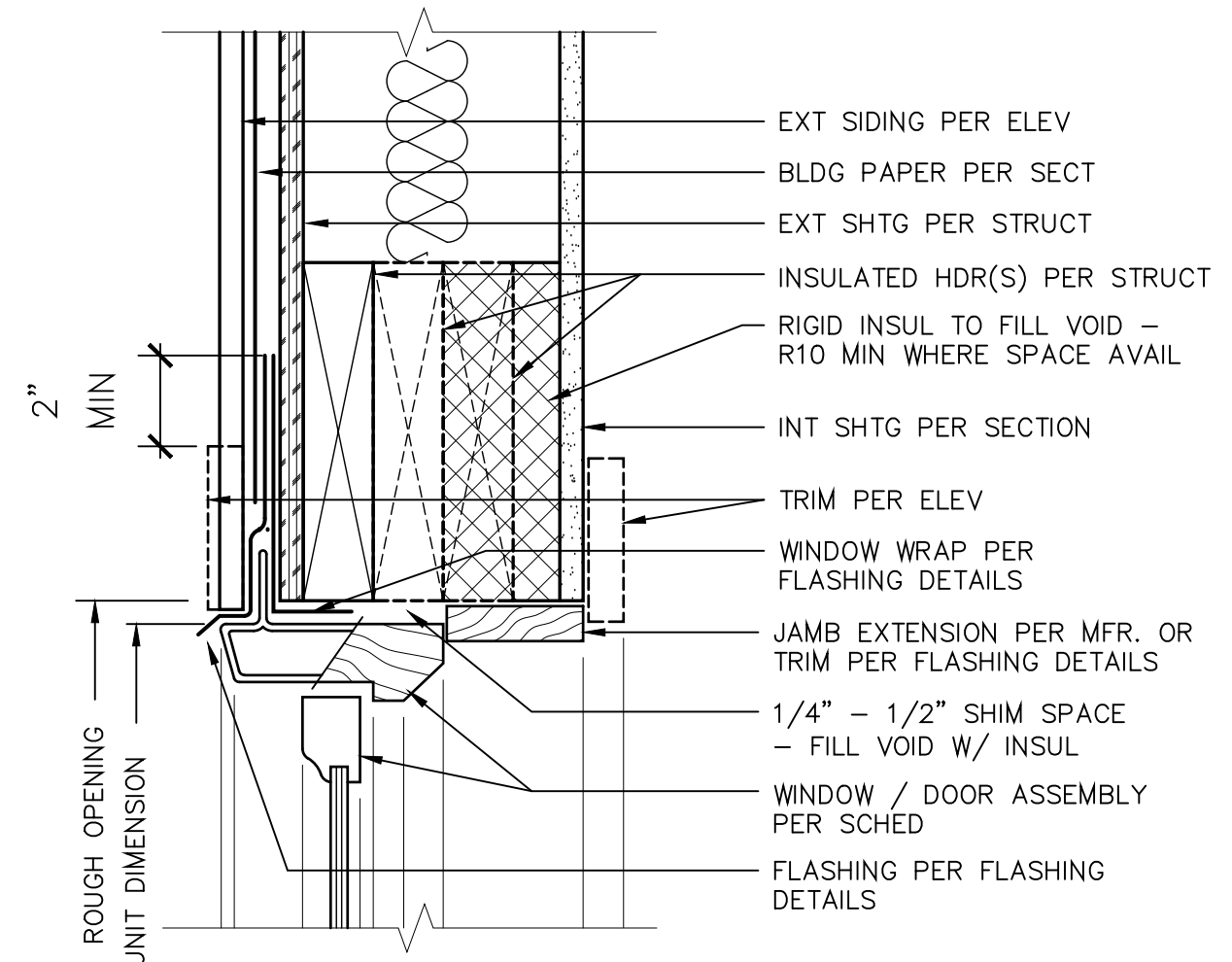

HEAD DETAIL

SCALE: 3" = 1'-0"

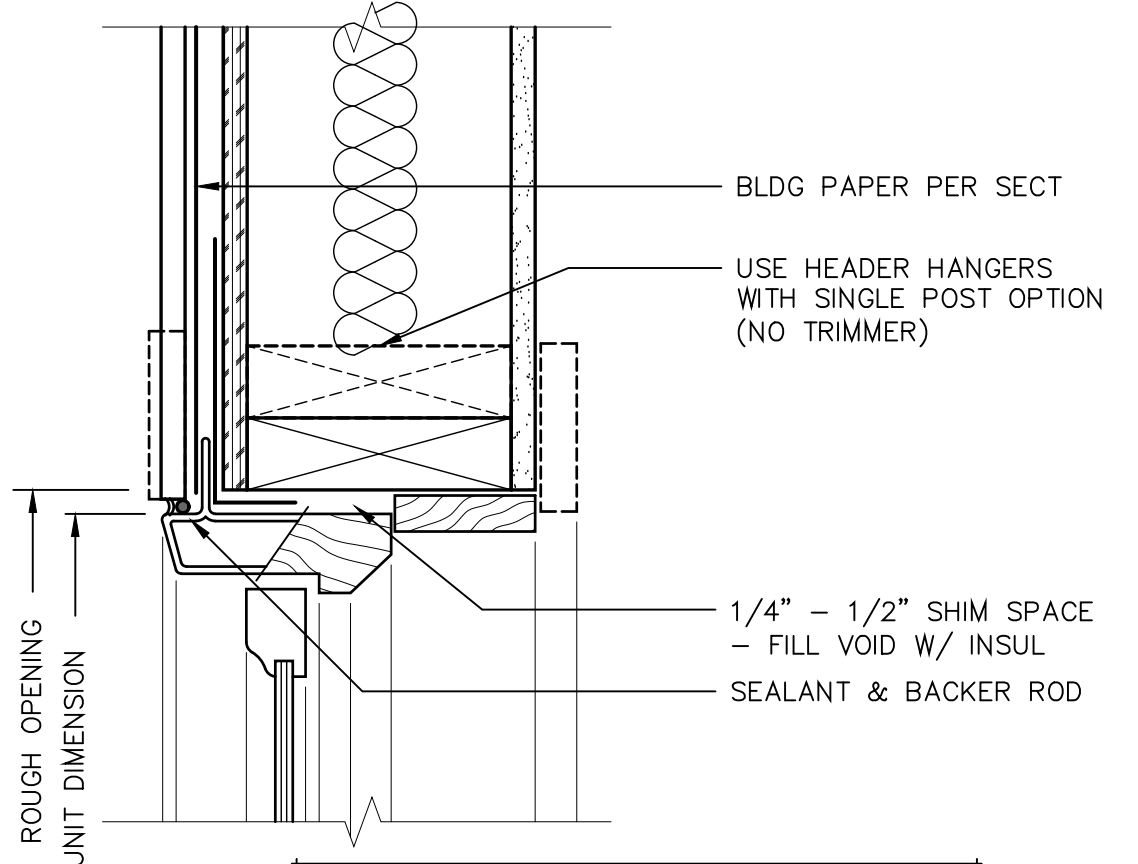

SEE HEAD DETAIL FOR NOTES IN COMMON

JAMB DETAIL

SCALE: 3" = 1'-0"

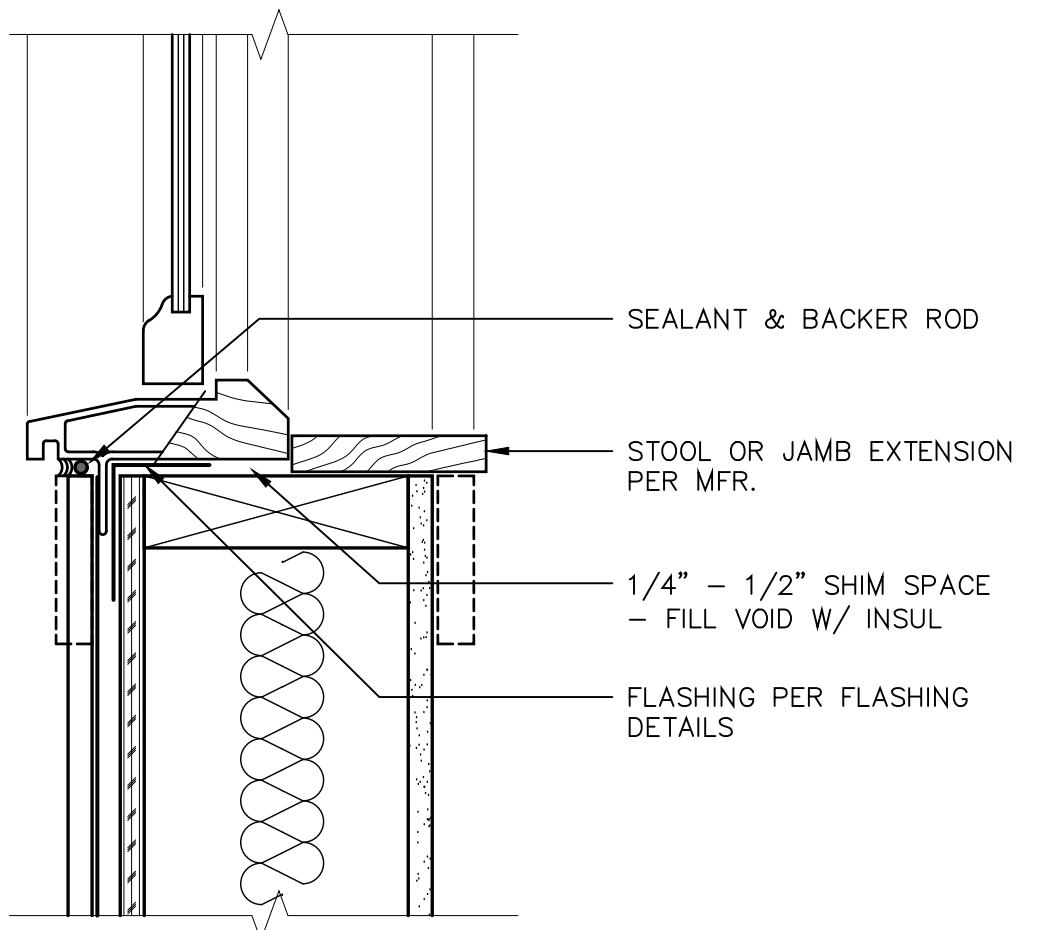

SEE HEAD DETAIL FOR NOTES IN COMMON

SILL DETAIL

SCALE: 3" = 1'-0"

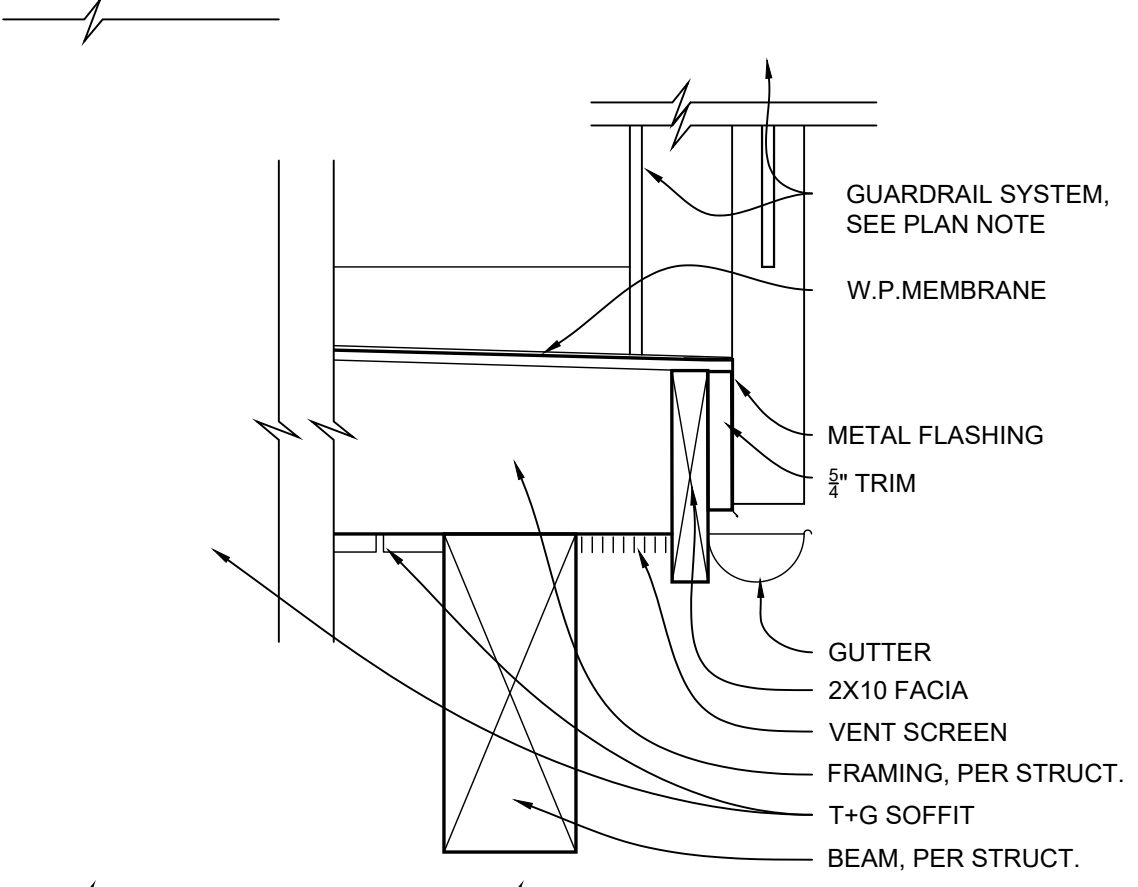

5 BALCONY DECK DETAIL

SCALE: 1 1/2" = 1'-0"

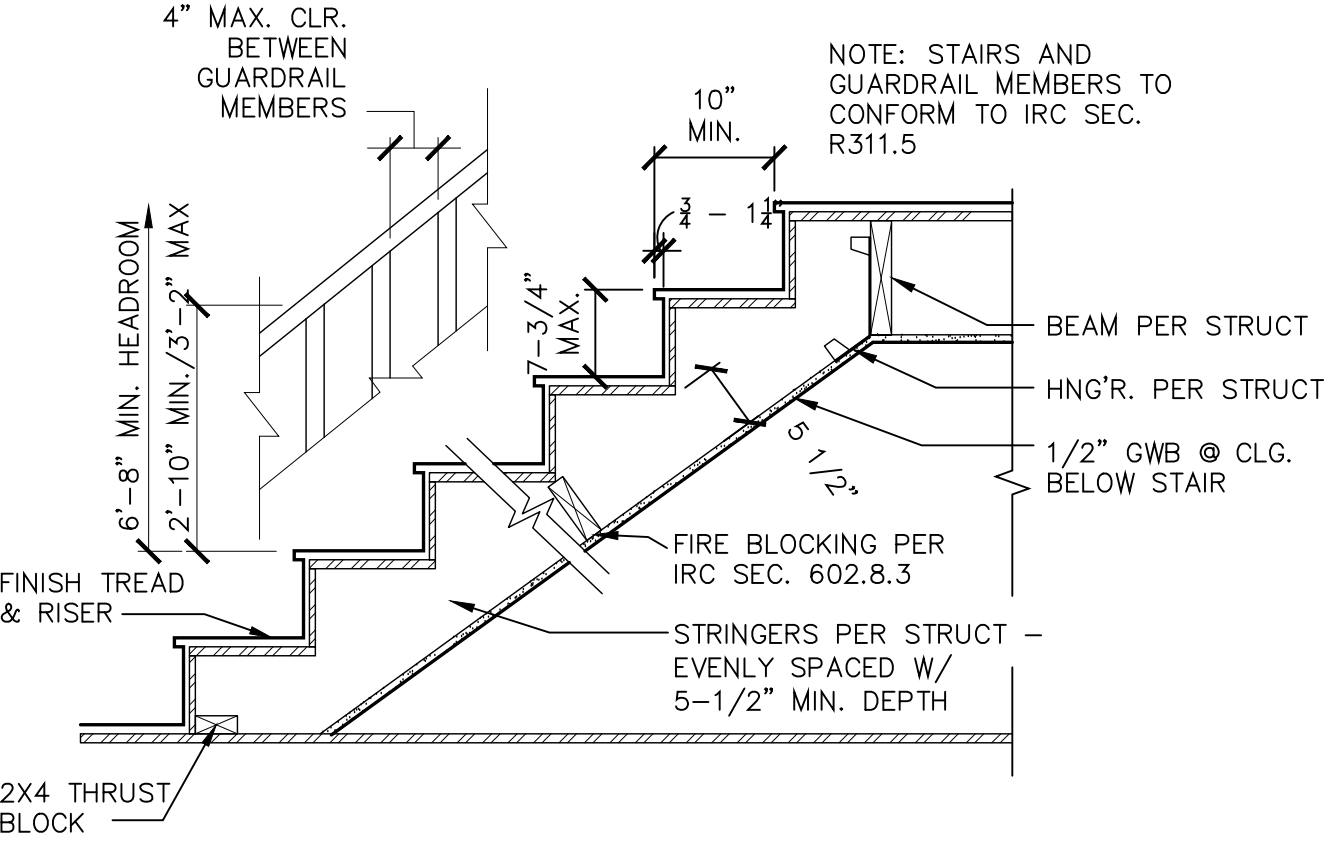

2 TYPICAL STAIR DETAIL

SCALE: 3/4" = 1'-0"

STR-002.dwg

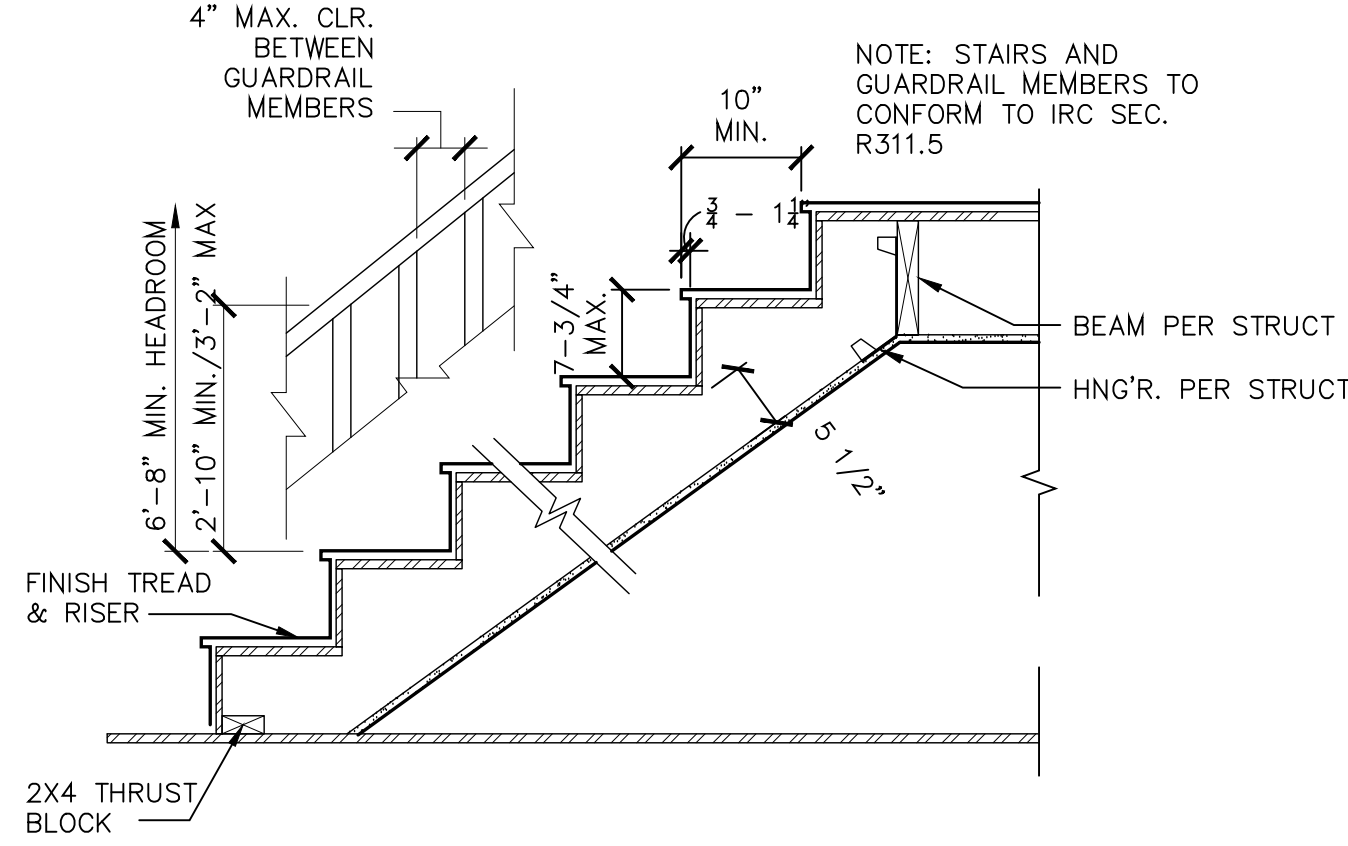

6 TYPICAL STAIR DETAIL EXT.

SCALE: 3/4" = 1'-0"

STR-002.dwg



LSA

LIVING SHELTER ARCHITECTS PLLC

472-A FRONT ST. N
ISSAQUAH, WA 98027
(425) 427-8643

© 2018 LSA. All rights reserved.

file **1644**

project name

BRENES REMODEL

project address
2675 74th Ave SE
Mercer Island, WA 98040

owner
CHRIS & JEN BRENES
619.957.5849
jenniferbrenes@comcast.net

project manager
ROY MCGARRAH
living shelter architects
425.427.8643
roy@livingshelter.com

survey
C & C SURVEYING, LLC
425.673.7502
ccsurveyllc@gmail.com

structural engineer
SWENSON SAY FAGET
206.443.6212
info@ssfengineers.com

geotechnical engineer
EARTH SOLUTIONS NW
425.284.3300
kevenh@esnw.com

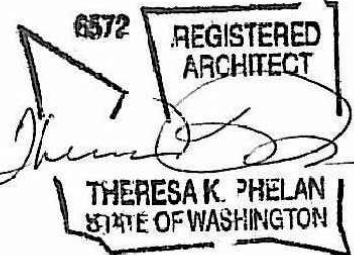

revisions
1 REV: 2/13/20

date **16 JAN 2020**

sheet title

DETAILS

sheet number

A5.02

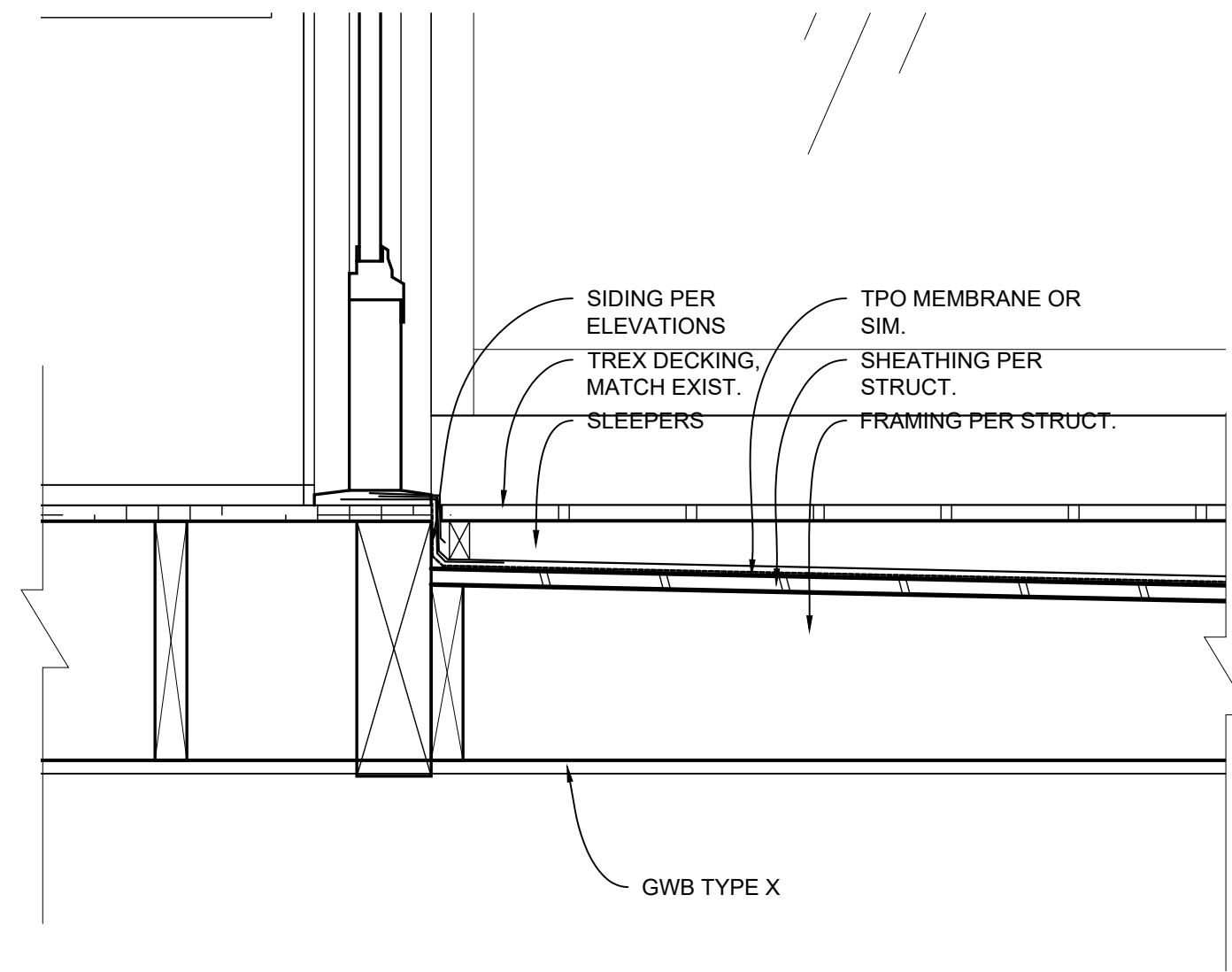

1 MBDRM DECK TRANSITION
1 1/2"=1'-0"

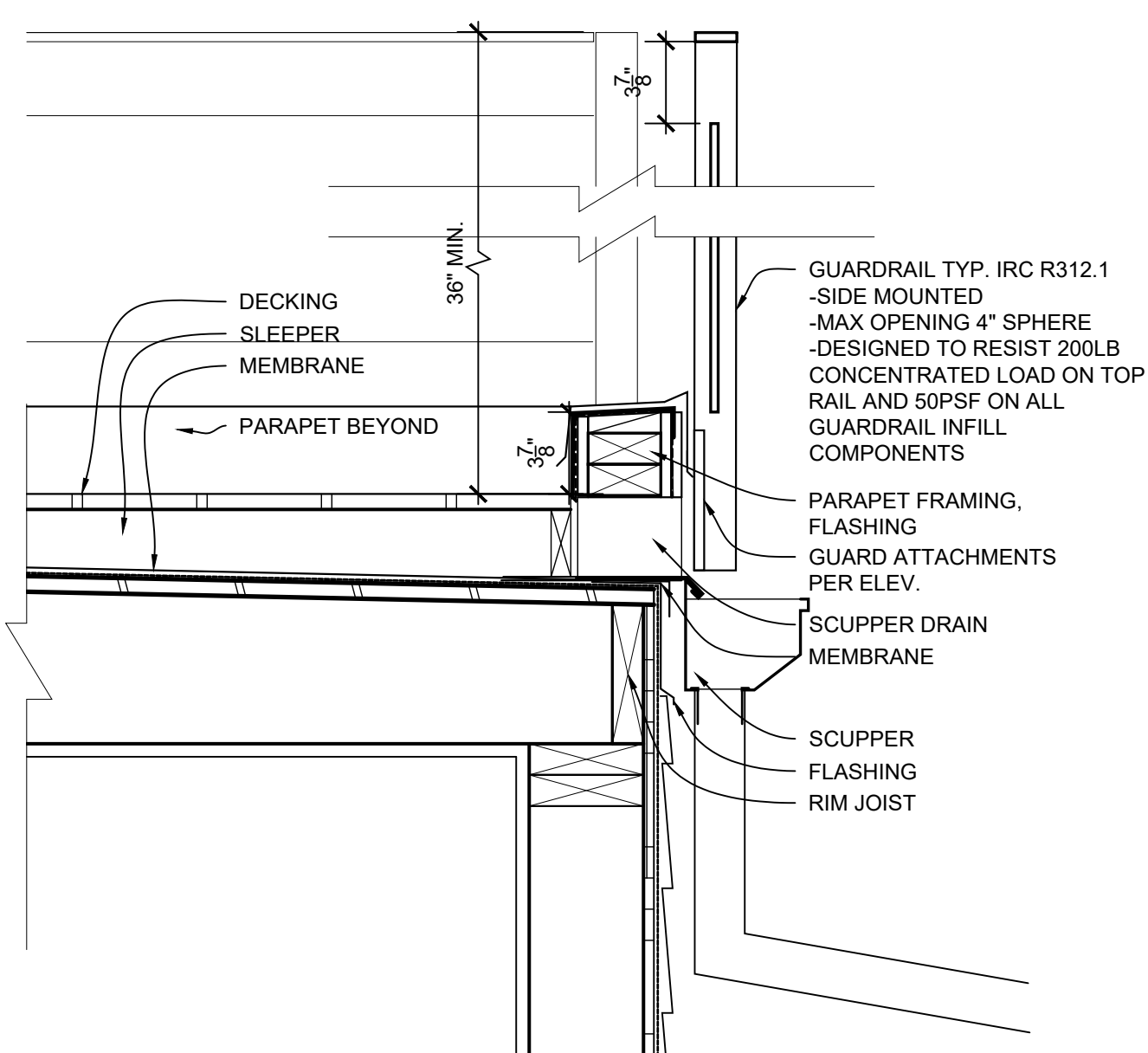

2 MBDRM DECK EDGE, GAURD
1 1/2"=1'-0"

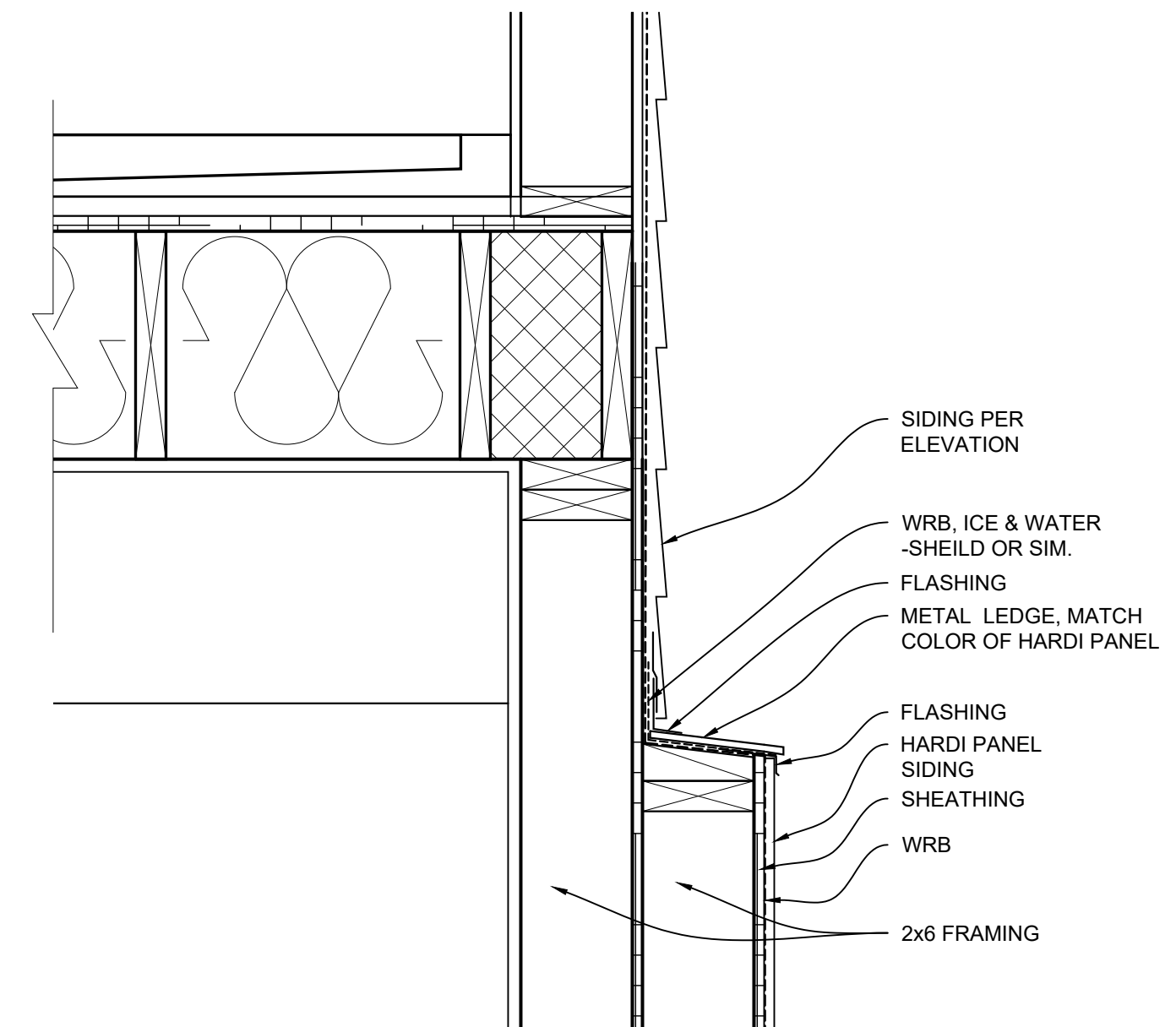

3 GARAGE DOUBLE WALL
1 1/2"=1'-0"

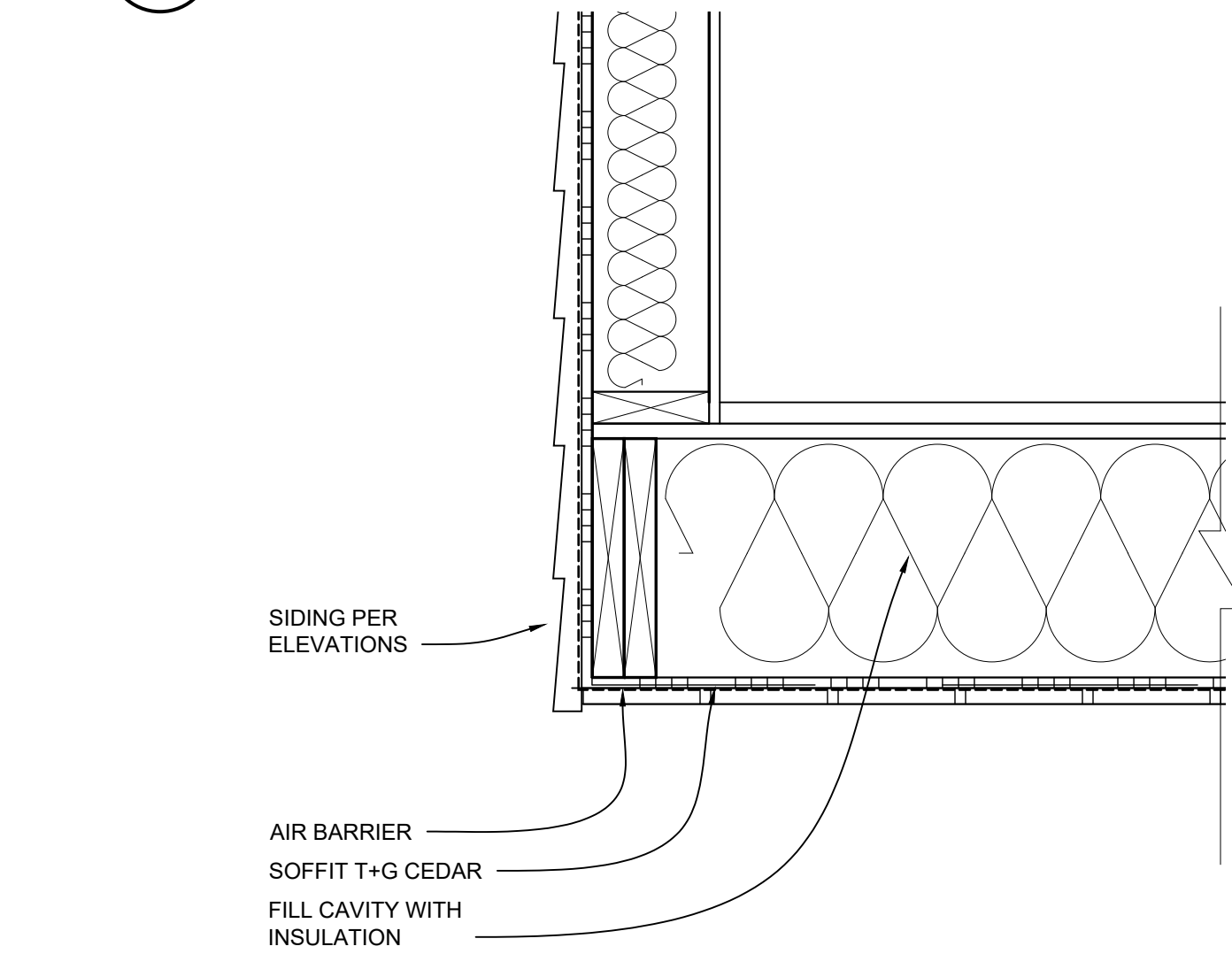

6 ENTRY SOFFIT
1 1/2"=1'-0"

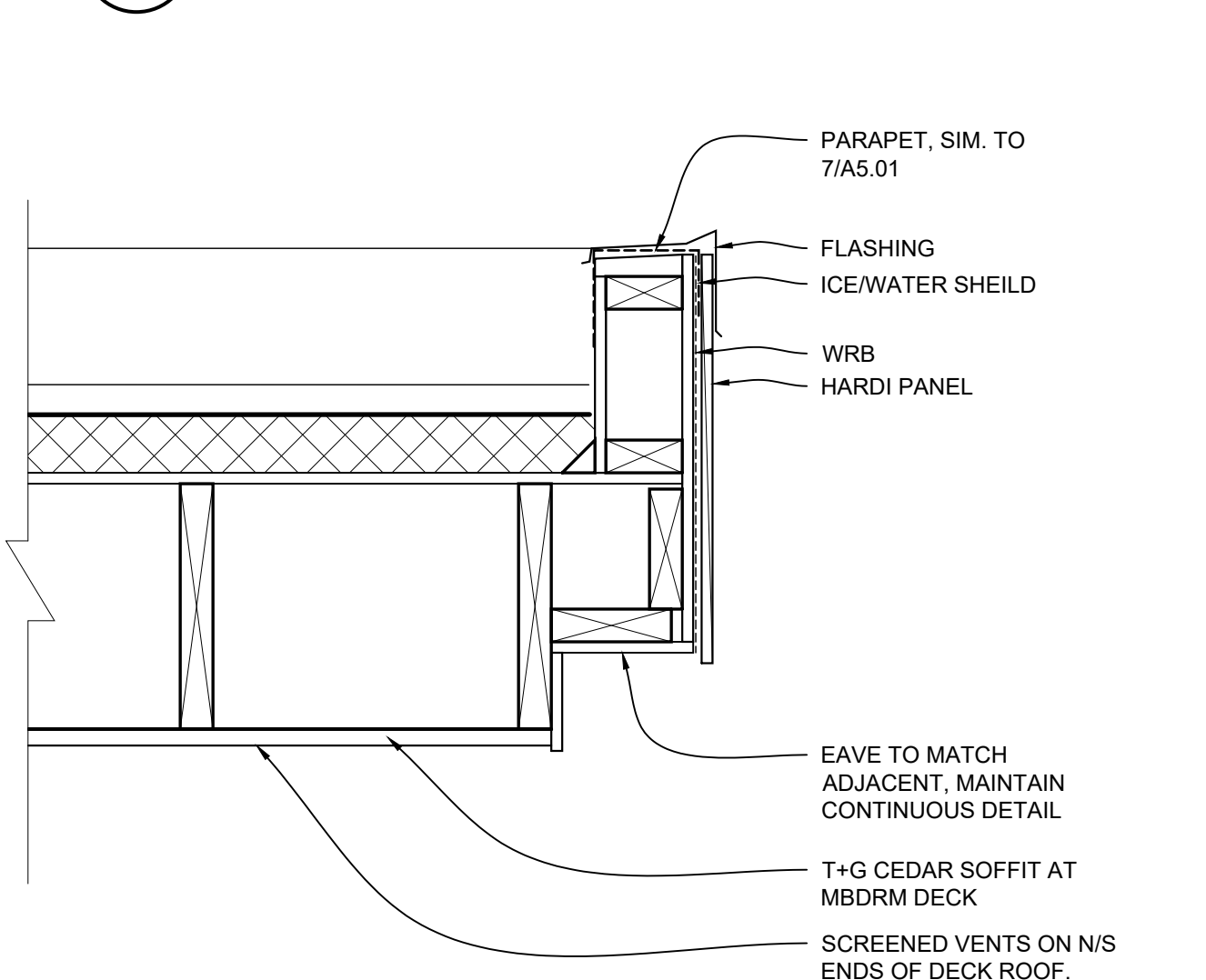

5 MBDRM DECK AWN
1 1/2"=1'-0"

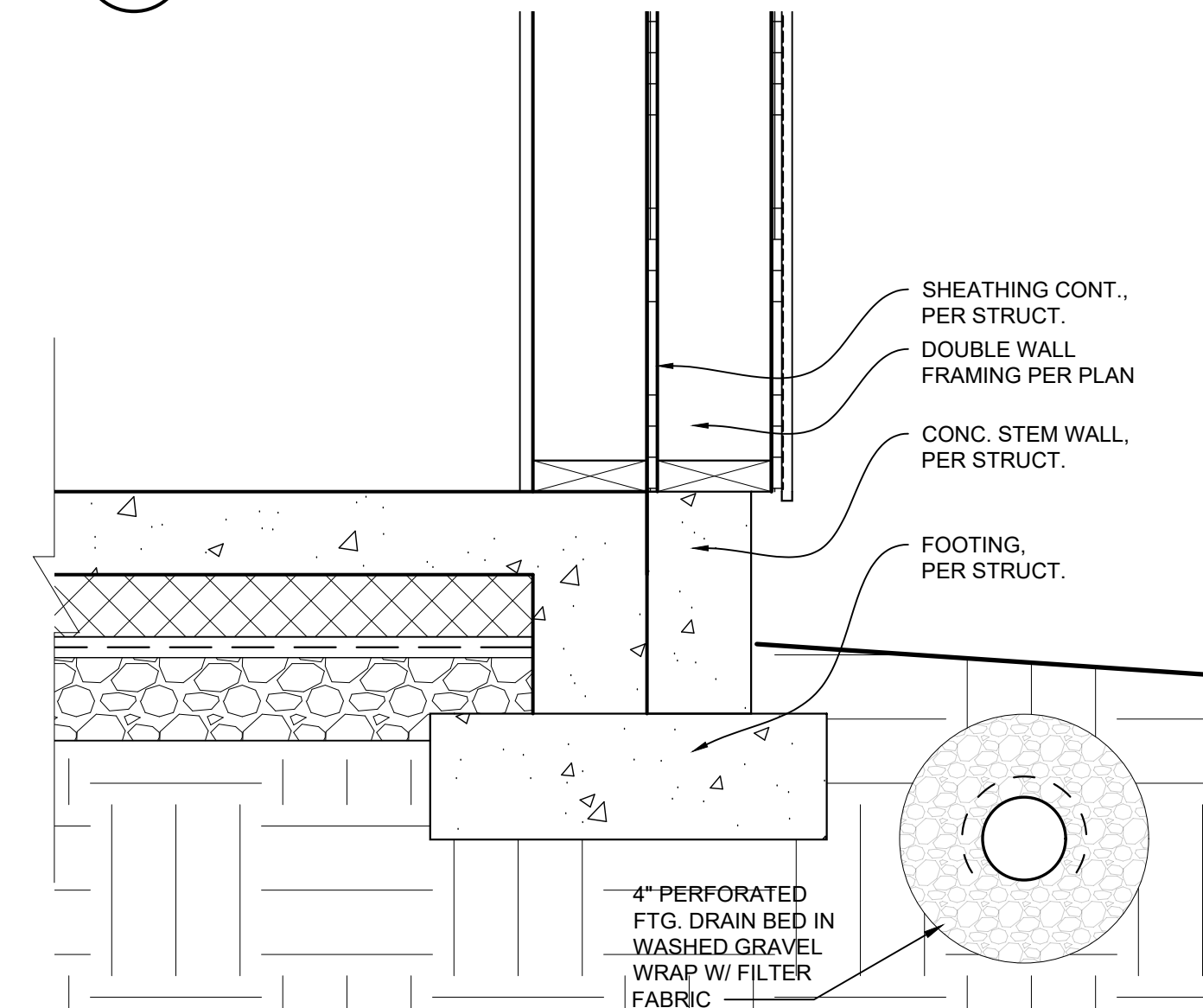

4 GARAGE DOUBLE WALL FOUND.
1 1/2"=1'-0"

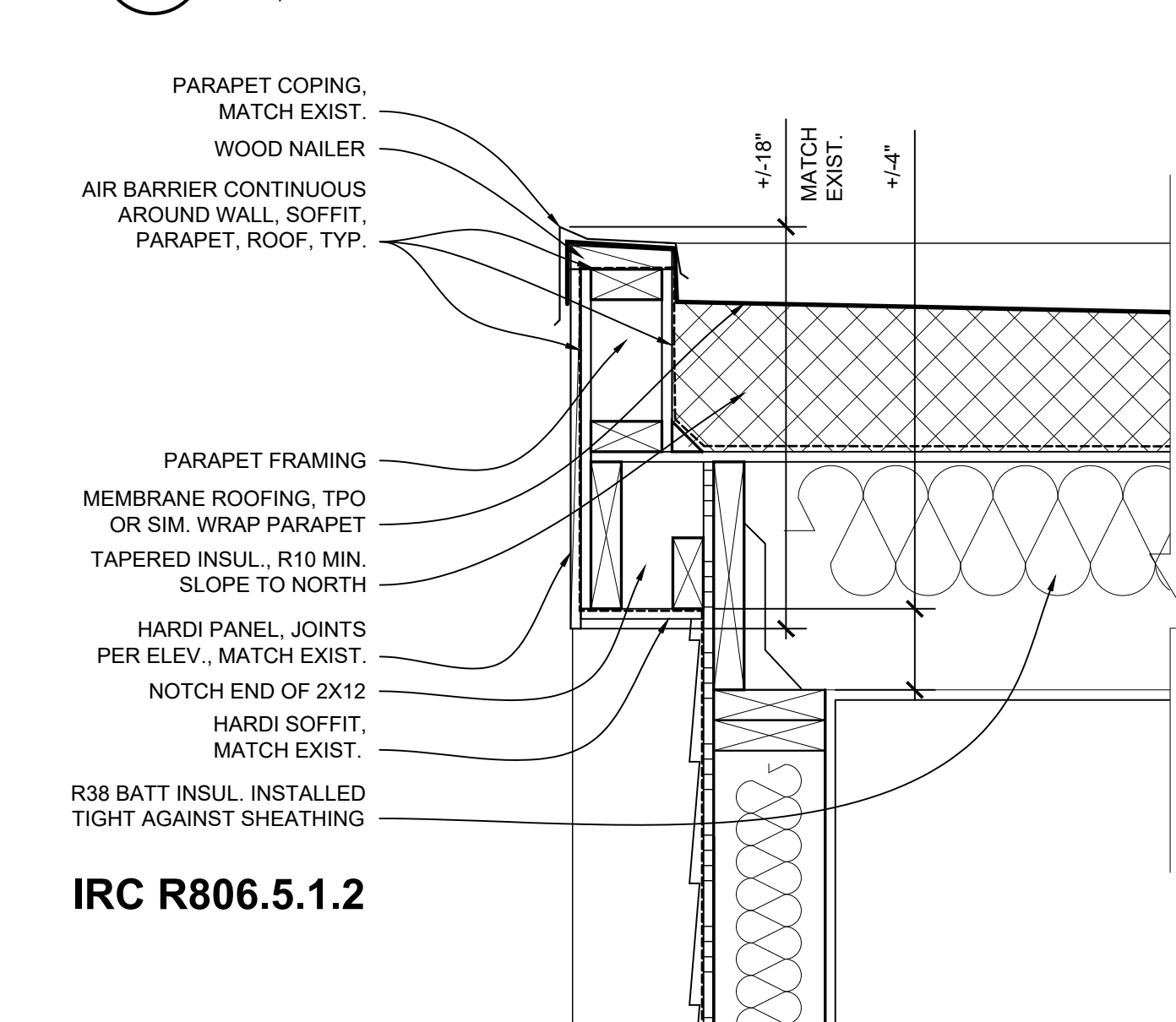

7 PARAPET TYP.
1 1/2"=1'-0"

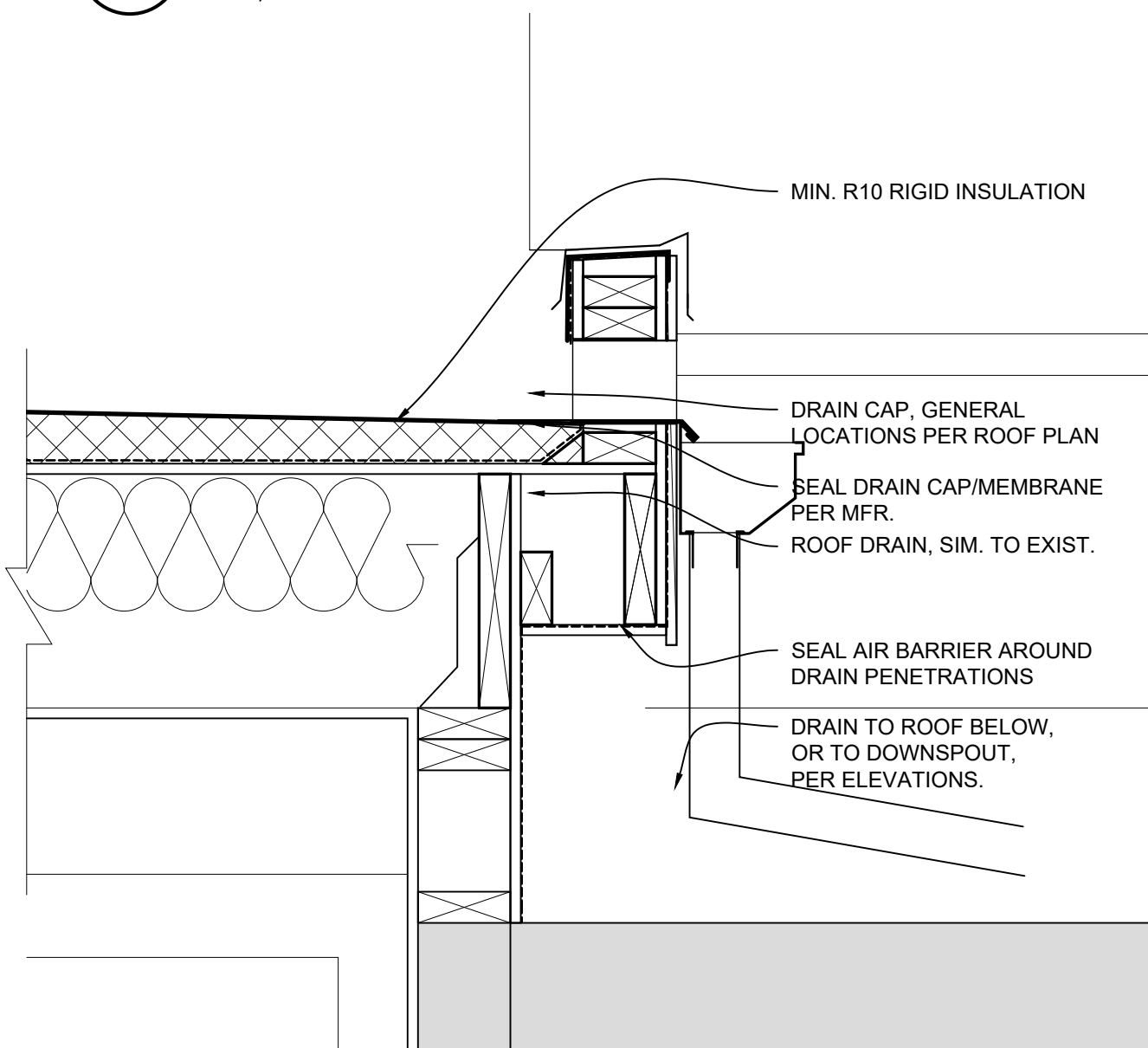

8 PARAPET DRAIN, TYP.
1 1/2"=1'-0"

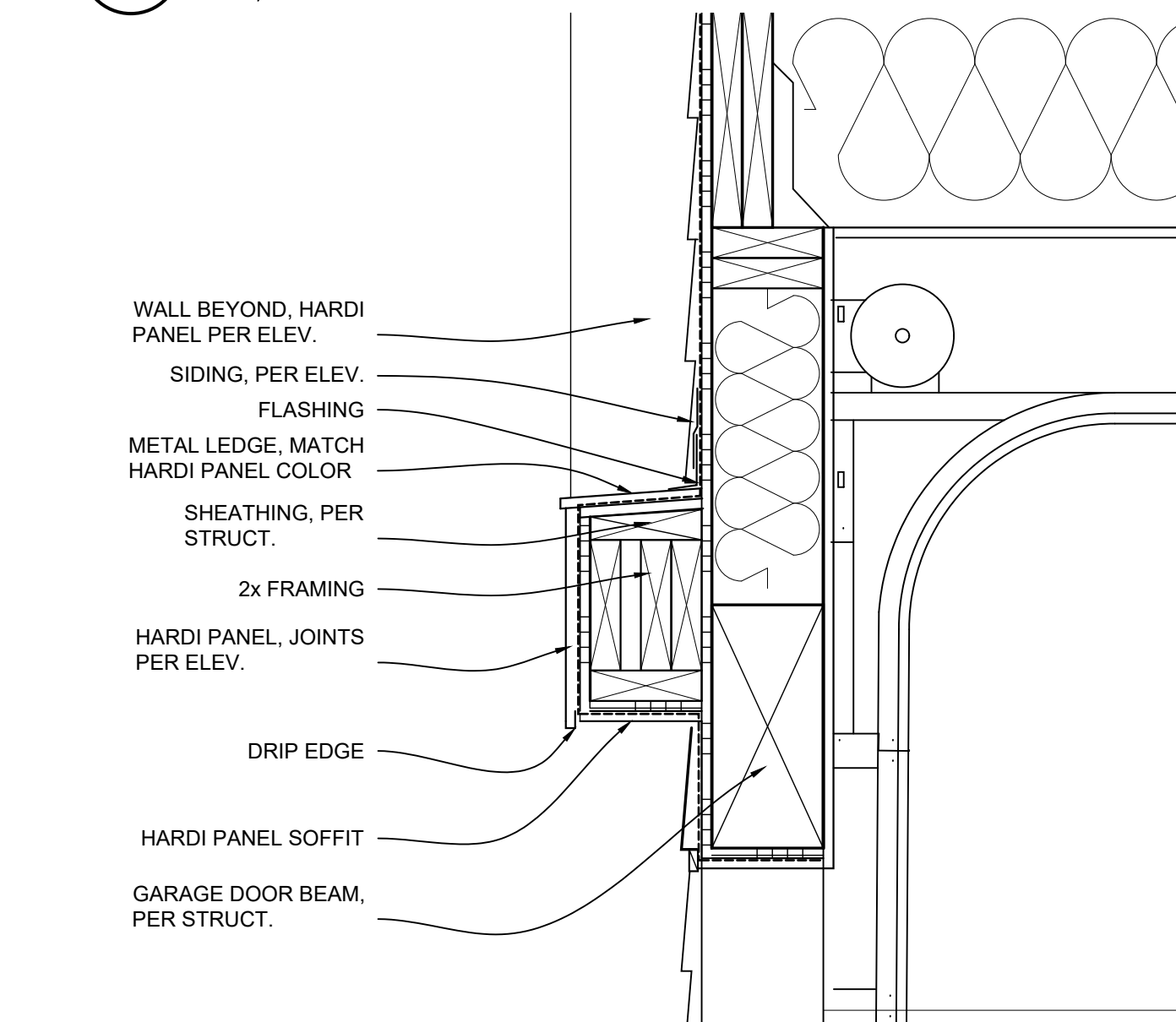

9 LEDGE @ GARAGE DOOR
1 1/2"=1'-0"



LSA

LIVING SHELTER ARCHITECTS PLLC

472-A FRONT ST. N
ISSAQUAH, WA 98027
(425) 427-8643

© 2018 LSA. All rights reserved.

file **1644**
project name

BRENES REMODEL

project address
2675 74th Ave SE
Mercer Island, WA 98040

owner
CHRIS & JEN BRENES
619.957.5849
jenniferbrenes@comcast.net

project manager
ROY MCGARRAH
living shelter architects
425.427.8643
roy@livingshelter.com

survey
C & C SURVEYING, LLC
425.673.7502
ccsurveyllc@gmail.com

structural engineer
SWENSON SAY FAGET
206.443.6212
info@ssfengineers.com

geotechnical engineer
EARTH SOLUTIONS NW
425.284.3300
kevenh@esnw.com

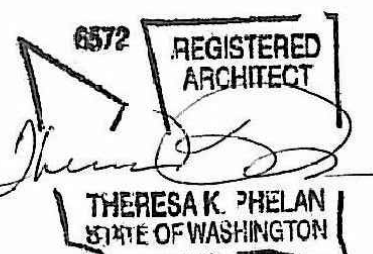

revisions
1 REV: 2/13/20

date **16 JAN 2020**

sheet title

DETAILS

sheet number

A5.01

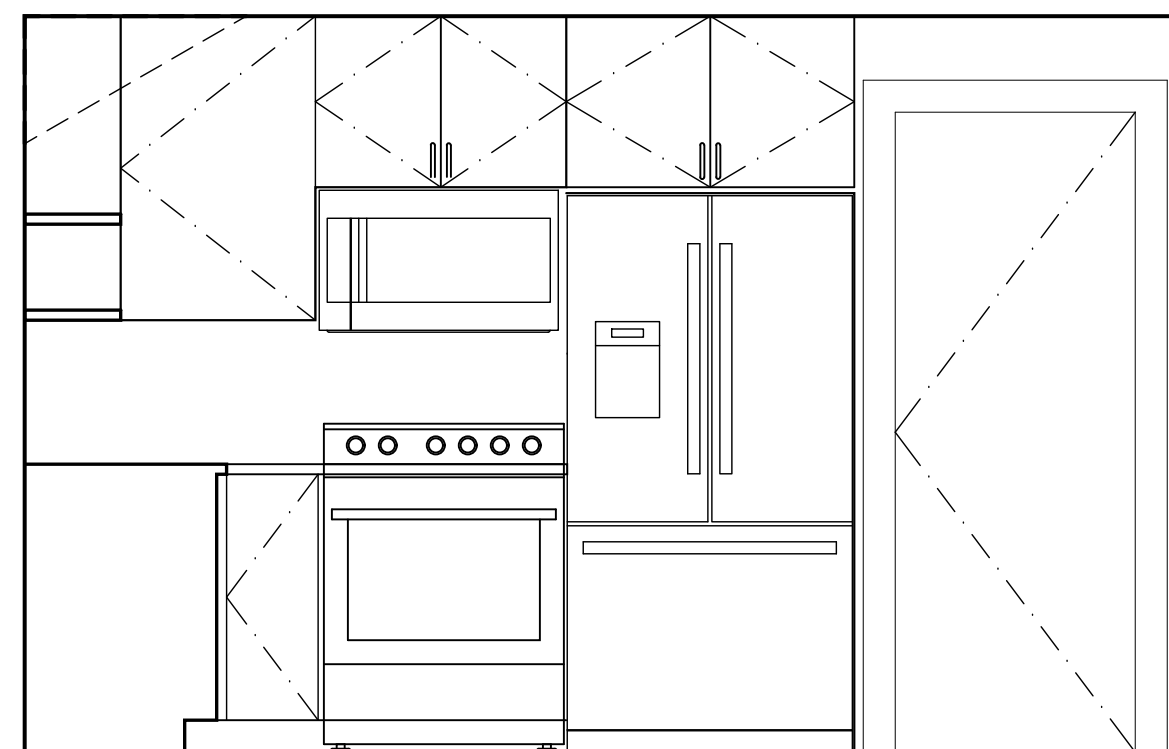

1 W. ADU KITCHEN
1/2"=1'-0"

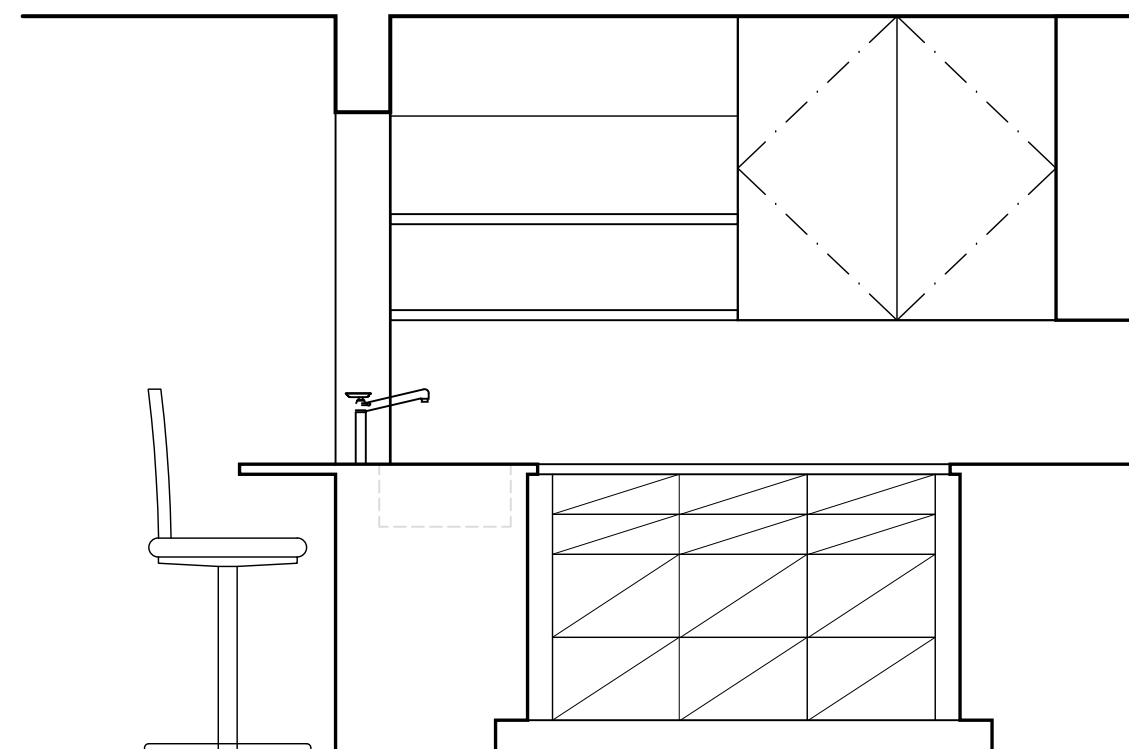

2 S. ADU KITCHEN
1/2"=1'-0"

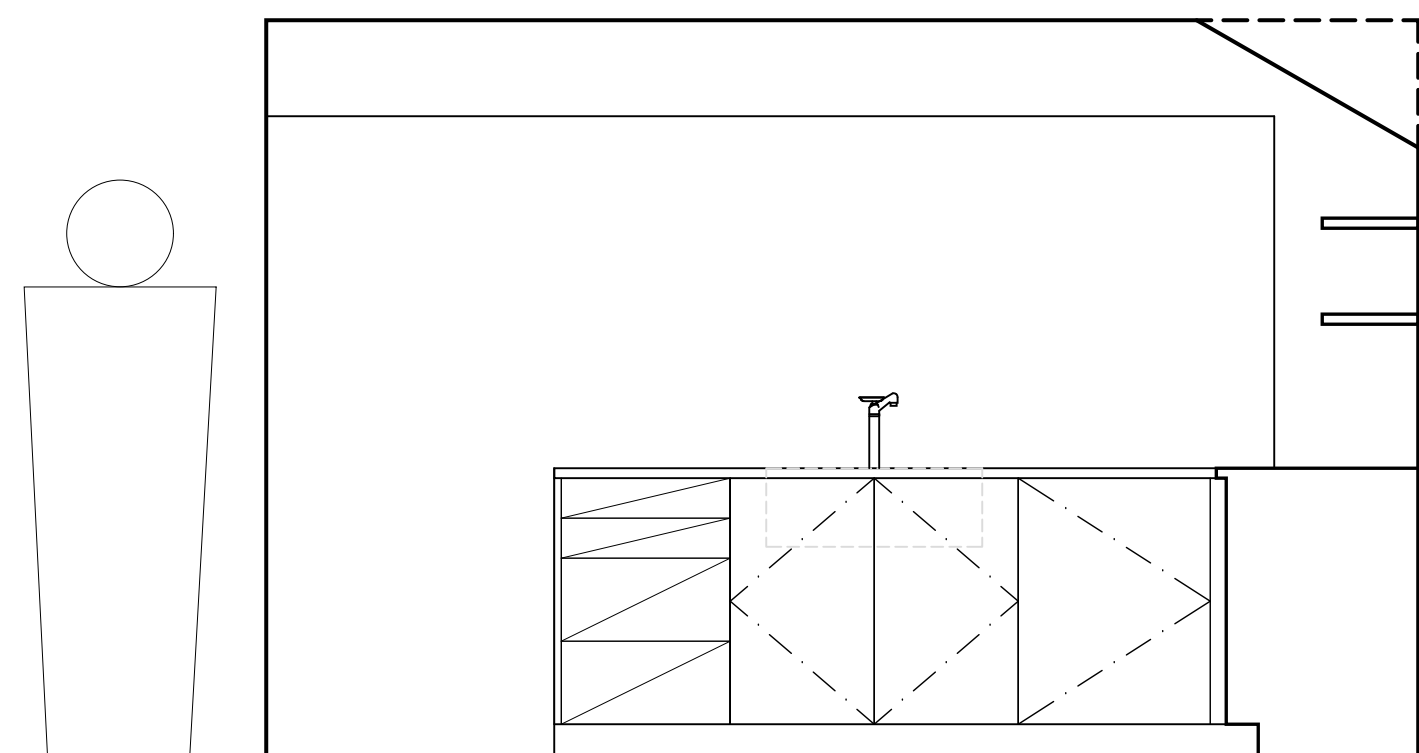

3 E. ADU KITCHEN
1/2"=1'-0"

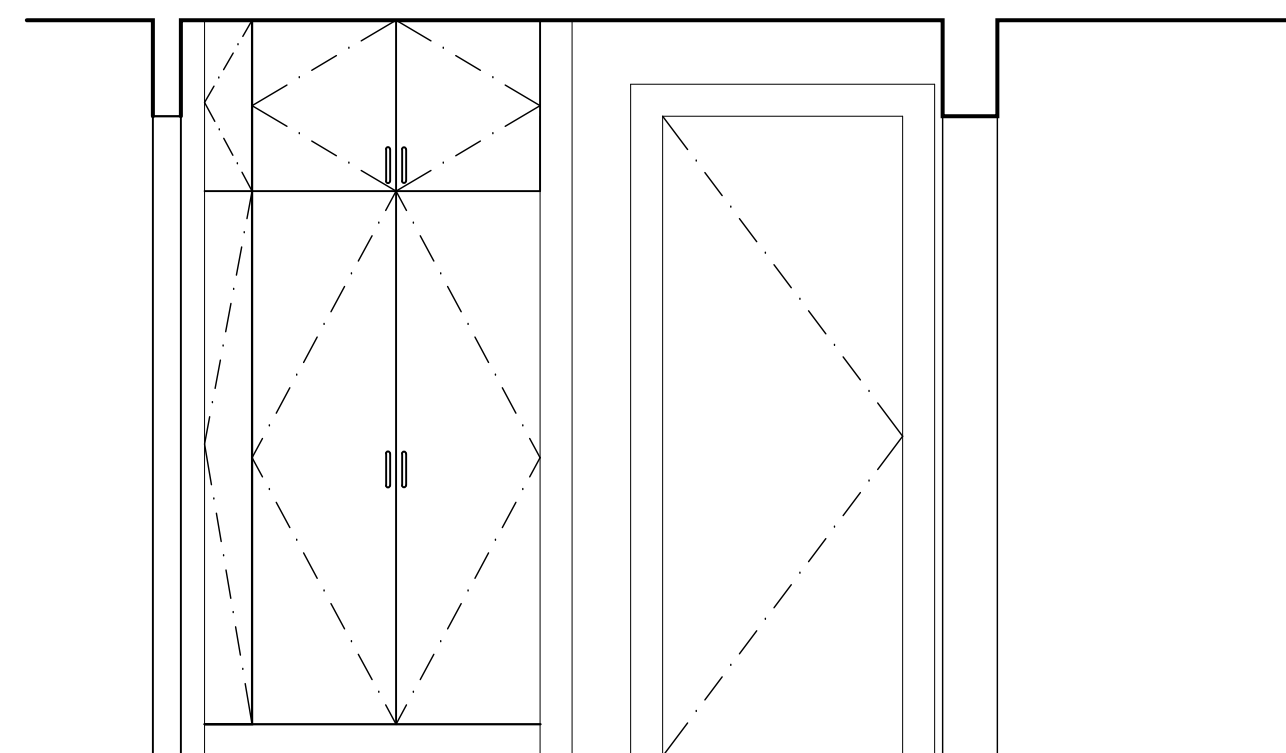

4 N. ADU KITCHEN
1/2"=1'-0"



LSA
LIVING SHELTER
ARCHITECTS
PLLC

472-A FRONT ST. N
ISSAQUAH, WA 98027
(425) 427-8643

© 2018 LSA. All rights reserved.

file
project name

1644
BRENES
REMODEL

project address
2675 74th Ave SE
Mercer Island, WA 98040

owner
CHRIS & JEN BRENES
619.957.5849
jenniferbrenes@comcast.net

project manager
ROY MCGARRAH
living shelter architects
425.427.8643
roy@livingshelter.com

survey
C & C SURVEYING, LLC
425.673.7502
ccsurveyllc@gmail.com

structural engineer
SWENSON SAY FAGET
206.443.6212
info@ssfengineers.com

geotechnical engineer
EARTH SOLUTIONS NW
425.284.3300
kevenh@esnw.com

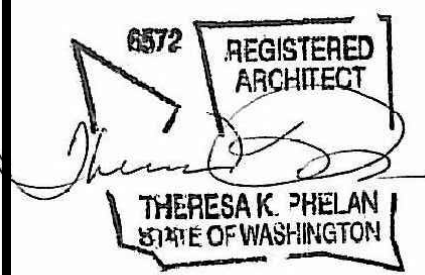

revisions
1 REV: 2/13/20

date
16 JAN 2020

sheet title
INTERIOR
ELEVATIONS

sheet number
A8.1

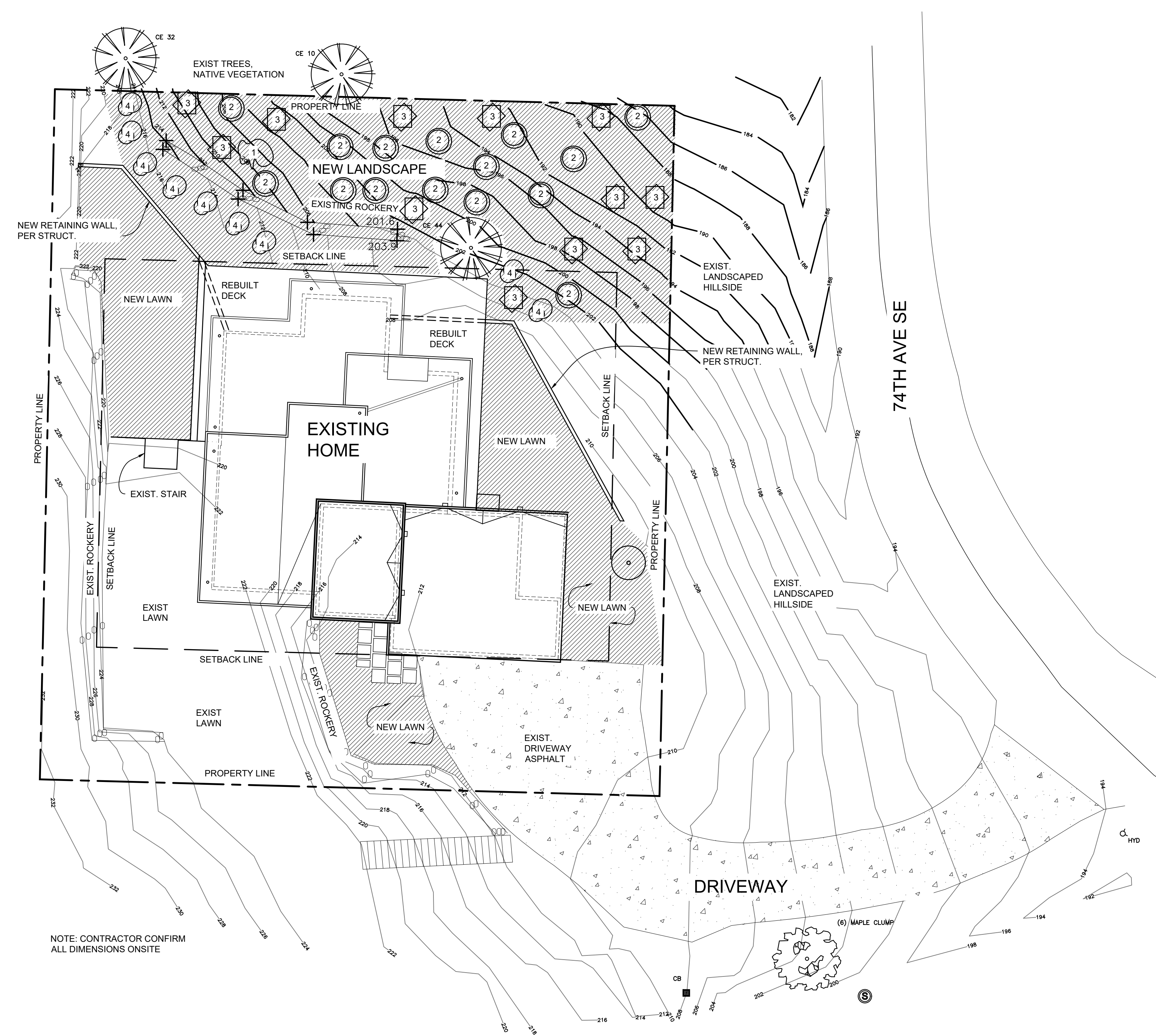
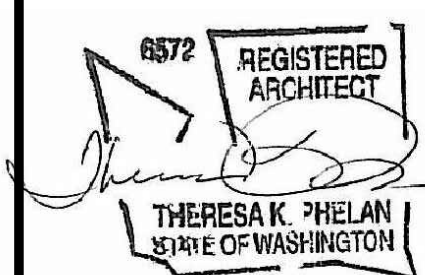

NOTE: CONTRACTOR CONFIRM ALL DIMENSIONS ONSITE

- NOTES:
- A) CONFIRM INSTALLATION OF CRUSHED ROCK ACCESS PAD. (WILL BE REMOVED UPON COMPLETION OF WORK)
 - B) CONNECT DOWNSPOUT LINES AND DIRECT TOWARD PREVIOUSLY INSTALLED CATCH BASIN AT NE CORNER.
 - C) MAINTAIN NATIVE VEGETATION (SWORD FERN, SALAL, BERRIES)
 - D) STABILIZE HILLSIDE WITH JUTE FABRIC/STAPLES AS NEEDED
- | NATIVE PLANT SCHEDULE FOR STEEP SLOPE: | SIZE | QTY |
|--|-------|-----|
| 1) CORNUS DOGWOOD, | 5-6" | X1 |
| 2) OREGON GRABE, MAHONIA NERVOSA, | 1 GAL | X15 |
| 3) SWORD FERN, POLYSTICHUM MUNITUM, | 1 GAL | X12 |
| 4) COMMON SNOWBERRY, SYMPHORICARPOS ALBUS, | 1 GAL | X9 |

LANDSCAPE DESIGNER :
DOUG DZINGLE
254-405-0154
DZINGL3@COMCAST.NET

1 LANDSCAPE PLAN
1" = 10'-0"

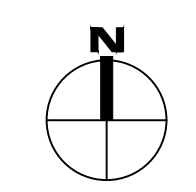

General Structural Notes

THE FOLLOWING APPLY UNLESS SHOWN OTHERWISE ON THE DRAWINGS

CRITERIA

- ALL MATERIALS, WORKMANSHIP, DESIGN, AND CONSTRUCTION SHALL CONFORM TO THE DRAWINGS, SPECIFICATIONS, AND THE INTERNATIONAL BUILDING CODE (2015 EDITION).
- DESIGN LOADING CRITERIA:
HANDRAILS AND GUARDS
GUARDRAILS/BALCONY RAILS 50 PLF
GUARDRAILS/BALCONY RAILS CONCENTRATED LOAD 200 LBS
RESIDENTIAL – ONE AND TWO-FAMILY DWELLINGS
FLOOR LIVE LOAD 40 PSF
DECKS 1.5 x AREA SERVED
ROOF
ROOF LIVE LOAD 35 PSF
MISCELLANEOUS LOADS
DECKS 1.5 x AREA SERVED
PARTITION LOADING 15 PSF
MECHANICAL UNITS WEIGHTS FURNISHED BY MANUFACTURER
DEFLECTION CRITERIA
LIVE LOAD DEFLECTION L/360
TOTAL LOAD DEFLECTION L/240
ENVIRONMENTAL LOADS
SNOW Ce=1.0, Is=1.0, Ct=1.1, Pg=25 PSF, Pf=20 PSF
WIND Kzt=1.25, GCpi=0.18, 110 MPH, RISK CATEGORY II, EXPOSURE "B"
EARTHQUAKE ANALYSIS PROCEDURE: EQUIVALENT LATERAL FORCE PROCEDURE
LATERAL SYSTEM: LIGHT FRAMED SHEAR WALLS
SITE CLASS=0, Ss=138, Sds=92, S1=53, SD1=53, Cs=0.142
SDC D, Ie=1.0, R=6.5
SEE PLANS FOR ADDITIONAL LOADING CRITERIA

- STRUCTURAL DRAWINGS SHALL BE USED IN CONJUNCTION WITH ARCHITECTURAL DRAWINGS FOR BIDDING AND CONSTRUCTION. ARCHITECTURAL DRAWINGS ARE THE PRIME CONTRACT DRAWINGS. ANY DISCREPANCIES FOUND AMONG THE DRAWINGS, THE SPECIFICATION, THESE GENERAL NOTES AND THE SITE CONDITIONS SHALL BE REPORTED TO THE ARCHITECT, WHO SHALL CORRECT SUCH DISCREPANCY IN WRITING. ANY WORK DONE BY THE GENERAL CONTRACTOR AFTER DISCOVERY OF SUCH DISCREPANCY SHALL BE DONE AT THE GENERAL CONTRACTOR'S RISK.
- PRIMARY STRUCTURAL ELEMENTS NOT DIMENSIONED ON THE STRUCTURAL PLANS AND DETAILS SHALL BE LOCATED BY THE ARCHITECTURAL PLANS AND DETAILS. VERTICAL DIMENSION CONTROL IS DEFINED BY THE ARCHITECTURAL WALL SECTIONS, BUILDING SECTION, AND PLANS. DETAILING AND SHOP DRAWING PRODUCTION FOR STRUCTURAL ELEMENTS WILL REQUIRE DIMENSIONAL INFORMATION CONTAINED IN BOTH ARCHITECTURAL AND STRUCTURAL DRAWINGS.
- CONTRACTOR SHALL BE RESPONSIBLE FOR ALL SAFETY PRECAUTIONS AND THE METHODS, TECHNIQUES, SEQUENCES OR PROCEDURES REQUIRED TO PERFORM THE CONTRACTOR'S WORK. THE STRUCTURAL ENGINEER HAS NO OVERALL SUPERVISORY AUTHORITY OR ACTUAL AND/OR DIRECT RESPONSIBILITY FOR THE SPECIFIC WORKING CONDITIONS AT THE SITE AND/OR FOR ANY HAZARDS RESULTING FROM THE ACTIONS OF ANY TRADE CONTRACTOR. THE STRUCTURAL ENGINEER HAS NO DUTY TO INSPECT, SUPERVISE, NOTE, CORRECT, OR REPORT ANY HEALTH OR SAFETY DEFICIENCIES TO THE OWNER, CONTRACTORS, OR OTHER ENTITIES OR PERSONS AT THE PROJECT SITE.
- CONTRACTOR SHALL PROVIDE TEMPORARY BRACING FOR THE STRUCTURE AND STRUCTURAL COMPONENTS UNTIL ALL FINAL CONNECTIONS HAVE BEEN COMPLETED IN ACCORDANCE WITH THE PLANS. CONFORM TO ASCE 37-14 "DESIGN LOADS ON STRUCTURES DURING CONSTRUCTION".
- CONTRACTOR-INITIATED CHANGES SHALL BE SUBMITTED IN WRITING TO THE ARCHITECT AND STRUCTURAL ENGINEER FOR APPROVAL PRIOR TO FABRICATION OR CONSTRUCTION. CHANGES SHOWN ON SHOP DRAWINGS ONLY WILL NOT SATISFY THIS REQUIREMENT.
- DRAWINGS INDICATE GENERAL AND TYPICAL DETAILS OF CONSTRUCTION. WHERE CONDITIONS ARE NOT SPECIFICALLY INDICATED BUT ARE OF SIMILAR CHARACTER TO DETAILS SHOWN, SIMILAR DETAILS OF CONSTRUCTION SHALL BE USED, SUBJECT TO REVIEW AND APPROVAL BY THE ARCHITECT AND THE STRUCTURAL ENGINEER. ALL TYPICAL NOTES AND DETAILS SHOWN ON DRAWINGS SHALL APPLY, UNLESS NOTED OTHERWISE. TYPICAL DETAILS MAY NOT NECESSARILY BE INDICATED ON THE PLANS BUT SHALL STILL APPLY AS SHOWN OR DESCRIBED IN THE DETAILS. WHERE TYPICAL DETAILS ARE NOTED ON THE PLANS, THE SPECIFIED TYPICAL DETAIL SHALL BE USED. WHERE NO TYPICAL DETAIL IS NOTED, IT SHALL BE THE CONTRACTOR'S RESPONSIBILITY TO CHOOSE THE APPROPRIATE TYPICAL DETAIL FROM THOSE PROVIDED OR REQUEST ADDITIONAL INFORMATION. THE CONTRACTOR SHALL SUBMIT ALL PROPOSED ALTERNATE TYPICAL DETAILS TO THOSE PROVIDED WITH RELATED CALCULATIONS TO THE ENGINEER FOR APPROVAL PRIOR TO SHOP DRAWING PRODUCTION AND FIELD USE.

QUALITY ASSURANCE

- SPECIAL INSPECTION SHALL BE PROVIDED IN ACCORDANCE WITH THE PROJECT SPECIFICATIONS AND SECTIONS 110 AND 1705 OF THE INTERNATIONAL BUILDING CODE BY A QUALIFIED TESTING AGENCY DESIGNATED BY THE ARCHITECT, AND RETAINED BY THE BUILDING OWNER. THE ARCHITECT, STRUCTURAL ENGINEER, AND BUILDING DEPARTMENT SHALL BE FURNISHED WITH COPIES OF ALL INSPECTION AND TEST RESULTS. SPECIAL INSPECTION OF THE FOLLOWING TYPES OF CONSTRUCTION IS REQUIRED UNLESS NOTED OTHERWISE.

DRIVEN DEEP FOUNDATION PER TABLE 1705.7

PERIODIC INSPECTION: INSPECTION SHALL BE PERFORMED AT INTERVALS NECESSARY TO CONFIRM THAT WORK REQUIRING SPECIAL INSPECTION IS IN COMPLIANCE WITH REQUIREMENTS.

CONTINUOUS INSPECTION: INSPECTOR SHALL BE ONSITE AND OBSERVE THE WORK REQUIRING INSPECTION AT ALL TIMES THAT WORK IS PERFORMED.

GEOTECHNICAL

- FOUNDATION NOTES: SUBGRADE PREPARATION INCLUDING DRAINAGE, EXCAVATION, COMPACTION, AND FILLING REQUIREMENTS, SHALL CONFORM STRICTLY WITH RECOMMENDATIONS GIVEN IN THE SOILS REPORT OR AS DIRECTED BY THE SOILS ENGINEER. FOOTINGS SHALL BEAR ON SOLID UNDISTURBED EARTH OR COMPACTED STRUCTURAL FILL AT LEAST 18" BELOW LOWEST ADJACENT FINISHED GRADE. FOOTING DEPTHS/ELEVATIONS SHOWN ON PLANS (OR IN DETAILS) ARE MINIMUM AND FOR GUIDANCE ONLY; THE ACTUAL ELEVATIONS OF FOOTINGS MUST BE ESTABLISHED BY THE CONTRACTOR IN THE FIELD WORKING WITH THE TESTING LAB AND SOILS ENGINEER. BACKFILL BEHIND ALL RETAINING WALLS WITH FREE DRAINING GRANULAR FILL AND PROVIDE FOR SUBSURFACE DRAINAGE AS NOTED IN THE SOILS REPORT.
ALLOWABLE SOIL PRESSURE 2500 PSF
LATERAL EARTH PRESSURE (RESTRAINED/UNRESTRAINED) 65 PCF/45 PCF
ALLOWABLE PASSIVE EARTH PRESSURE (FS OF 1.5 INCLUDED) 225 PCF
COEFFICIENT OF FRICTION (FS OF 1.5 INCLUDED) 0.35
SEISMIC SURCHARGE PRESSURE (UNIFORM LOAD) 8H PSF
2½ DIAMETER PILE CAPACITY (COMPRESSION ONLY) 6 KIP
SOILS REPORT REFERENCE: EARTH SOLUTIONS NW LLC

- PIN PILES SHOWN ON THE PLAN SHALL BE 2" DIAMETER SCHEDULE 80. THE MAXIMUM CAPACITY OF 2" PILES SHALL BE 3 TONS. ALL PILES SHALL BE DRIVEN TO REFUSAL IN ACCORDANCE WITH THE GEOTECHNICAL REPORT. AS A MINIMUM, PILE REFUSAL SHALL BE DEFINED AS 1 INCH OF PENETRATION IN 60 SECONDS DURING CONTINUOUS DRIVING OF A 90 LB JACK HAMMER UNDER THE FULL WEIGHT AND EFFORT OF THE OPERATOR. PILES USED IN COMMON TO RESIST LATERAL EARTH PRESSURES SHALL HAVE THE ADDITIONAL REQUIREMENT OF BEING EMBEDDED A MINIMUM OF 10 FEET BELOW RETAINED GRADE. THE MAXIMUM PILE ECCENTRICITY SHALL BE 2 INCHES. GEOTECHNICAL SPECIAL INSPECTION SHALL BE SUBJECT TO THE DISCRETION OF THE GEOTECHNICAL ENGINEER AND THE BUILDING DEPARTMENT. SEE PLANS FOR OTHER SIZES AND CRITERIA.

RENOVATION

- DEMOLITION: CONTRACTOR SHALL VERIFY ALL EXISTING CONDITIONS BEFORE COMMENCING ANY DEMOLITION. SHORING SHALL BE INSTALLED TO SUPPORT EXISTING CONSTRUCTION AS REQUIRED AND IN A MANNER SUITABLE TO THE WORK SEQUENCES. DEMOLITION DEBRIS SHALL NOT BE ALLOWED TO DAMAGE OR OVERLOAD THE EXISTING STRUCTURE. LIMIT CONSTRUCTION LOADING (INCLUDING DEMOLITION DEBRIS) ON EXISTING FLOOR SYSTEMS TO 40 PSF.
- CONTRACTOR SHALL VERIFY ALL EXISTING DIMENSIONS, MEMBER SIZES, AND CONDITIONS PRIOR TO COMMENCING ANY WORK. ALL DIMENSIONS OF EXISTING CONSTRUCTION SHOWN ON THE DRAWINGS ARE INTENDED AS GUIDELINES ONLY AND MUST BE VERIFIED. THE CONTRACTOR SHALL NOTIFY THE ARCHITECT AND STRUCTURAL ENGINEER IF EXISTING CONDITIONS DETERMINED DURING WORK VARY FROM THE EXISTING CONSTRUCTION SHOWN ON THE DRAWINGS.
- EXISTING REINFORCING SHALL BE SAVED WHERE AND AS NOTED ON THE PLANS. SAW CUTTING, IF AND WHERE USED, SHALL NOT CUT EXISTING REINFORCING THAT IS TO BE SAVED.
 - ALL NEW OPENINGS THROUGH EXISTING WALLS, SLABS AND BEAMS SHALL BE ACCOMPLISHED BY SAW CUTTING WHEREVER POSSIBLE. CORNERS SHALL NOT BE OVERCUT.
 - CONTRACTOR SHALL VERIFY ALL EXISTING CONDITIONS AND LOCATION OF MEMBERS PRIOR TO CUTTING ANY OPENINGS.
 - SMALL ROUND OPENINGS SHALL BE ACCOMPLISHED BY CORE DRILLING.
 - WHERE NEW REINFORCING TERMINATES AT EXISTING CONCRETE, DRILL AND EPOXY DOWELS MATCHING THE NEW REINFORCING INTO THE EXISTING CONCRETE WITH 6" EMBED, UNLESS OTHERWISE NOTED ON PLANS.
- CONTRACTOR SHALL CHECK FOR DRY ROT AT ALL AREAS OF NEW WORK. ALL ROT SHALL BE REMOVED AND DAMAGED MEMBERS SHALL BE REPLACED OR REPAIRED AS DIRECTED BY THE STRUCTURAL ENGINEER OR ARCHITECT.

CONCRETE

- CONCRETE SHALL BE MIXED, PROPORTIONED, CONVEYED AND PLACED IN ACCORDANCE WITH ACI 301, INCLUDING TESTING PROCEDURES. CONCRETE SHALL ATTAIN A 28-DAY STRENGTH OF $f'c = 3,000$ PSI AND MIX SHALL CONTAIN NOT LESS THAN 5-1/2 SACKS OF CEMENT PER CUBIC YARD AND SHALL BE PROPORTIONED TO PRODUCE A SLUMP OF 5" OR LESS. REQUIRED CONCRETE STRENGTH IS BASED ON THE DURABILITY REQUIREMENTS OF SECTION 1904 OF THE IBC. DESIGN STRENGTH IS $f'c = 2,500$ PSI.
- ALL CONCRETE WITH SURFACES EXPOSED TO WEATHER OR STANDING WATER SHALL BE AIR-ENTRAINED WITH AN AIR-ENTRAINING AGENT CONFORMING TO ASTM C260, C494, AND C618. TOTAL AIR CONTENT FOR FROST-RESISTANT CONCRETE SHALL BE IN ACCORDANCE WITH ACI 318-14, TABLE 19.3.2.1 MODERATE EXPOSURE, F1.
- REINFORCING STEEL SHALL CONFORM TO ASTM A615 (INCLUDING SUPPLEMENT S1), GRADE 60, FY = 60,000 PSI. EXCEPTIONS: ANY BARS SPECIFICALLY SO NOTED ON THE DRAWINGS SHALL BE GRADE 40, FY = 40,000 PSI. WELDED WIRE FABRIC SHALL CONFORM TO ASTM A-185. SPIRAL REINFORCEMENT SHALL BE DEFORMED WIRE CONFORMING TO ASTM A615, GRADE 60, FY = 60,000 PSI.
- DETAILING OF REINFORCING STEEL (INCLUDING HOOKS AND BENDS) SHALL BE IN ACCORDANCE WITH ACI 315-99 AND 318-14. LAP ALL CONTINUOUS REINFORCEMENT #5 AND SMALLER 40 BAR DIAMETERS OR 2'-0" MINIMUM. PROVIDE CORNER BARS AT ALL WALL AND FOOTING INTERSECTIONS. LAP CORNER BARS #5 AND SMALLER 40 BAR DIAMETERS OR 2'-0" MINIMUM. LAPS OF LARGER BARS SHALL BE MADE IN ACCORDANCE WITH ACI 318-14, CLASS B. LAP ADJACENT MATS OF WELDED WIRE FABRIC A MINIMUM OF 8" AT SIDES AND ENDS.
NO BARS PARTIALLY EMBEDDED IN HARDENED CONCRETE SHALL BE FIELD BENT UNLESS SPECIFICALLY SO DETAILED OR APPROVED BY THE STRUCTURAL ENGINEER.
- CONCRETE PROTECTION (COVER) FOR REINFORCING STEEL SHALL BE AS FOLLOWS:
FOOTINGS AND OTHER UNFORMED SURFACES CAST AGAINST AND PERMANENTLY EXPOSED TO EARTH 3"
FORMED SURFACES EXPOSED TO EARTH OR WEATHER (#6 BARS OR LARGER) 2"
FORMED SURFACES EXPOSED TO EARTH OR WEATHER (#5 BARS OR SMALLER) 1-1/2"
COLUMN TIES OR SPIRALS AND BEAM STIRRUPS 1-1/2"
SLABS AND WALLS (INT. FACE) GREATER OF BAR DIAMETER PLUS 1/8" OR 3/4"

- CONCRETE WALL REINFORCING--PROVIDE THE FOLLOWING UNLESS DETAILED OTHERWISE:

6" WALLS	#4 @ 16 HORIZ.	#4 @ 18 VERTICAL	1 CURTAIN
8" WALLS	#4 @ 12 HORIZ.	#4 @ 18 VERTICAL	1 CURTAIN
10" WALLS	#4 @ 18 HORIZ.	#4 @ 18 VERTICAL	2 CURTAINS
12" WALLS	#4 @ 16 HORIZ.	#4 @ 18 VERTICAL	2 CURTAINS

- CAST-IN-PLACE CONCRETE: SEE ARCHITECTURAL DRAWINGS FOR EXACT LOCATIONS AND DIMENSIONS OF DOOR AND WINDOW OPENINGS IN ALL CONCRETE WALLS. SEE MECHANICAL DRAWINGS FOR SIZE AND LOCATION OF MISCELLANEOUS MECHANICAL OPENINGS THROUGH CONCRETE WALLS. SEE ARCHITECTURAL DRAWINGS FOR ALL GROOVES, NOTCHES, CHAMFERS, FEATURE STRIPS, COLOR, TEXTURE, AND OTHER FINISH DETAILS AT ALL EXPOSED CONCRETE SURFACES, BOTH CAST-IN-PLACE AND PRECAST.

- NON-SHRINK GROUT SHALL BE FURNISHED BY AN APPROVED MANUFACTURER AND SHALL BE MIXED AND PLACED IN STRICT ACCORDANCE WITH THE MANUFACTURER'S PUBLISHED RECOMMENDATIONS. GROUT STRENGTH SHALL BE AT LEAST EQUAL TO THE MATERIAL ON WHICH IT IS PLACED (3000 PSI MINIMUM).

ANCHORAGE

- EXPANSION BOLTS INTO CONCRETE SHALL BE "STRONG-BOLT 2" WEDGE ANCHORS AS MANUFACTURED BY THE SIMPSON STRONG-TIE COMPANY AND INSTALLED IN STRICT CONFORMANCE TO ICC-ES REPORT NUMBER ESR-3037, INCLUDING MINIMUM EMBEDMENT REQUIREMENTS. BOLTS INTO CONCRETE MASONRY OR BRICK MASONRY UNITS SHALL BE INTO FULLY GROUTED CELLS. PERIODIC SPECIAL INSPECTION IS REQUIRED TO VERIFY ANCHOR TYPE, ANCHOR DIMENSIONS, ANCHOR LOCATION, TIGHTENING TORQUE, HOLE DIMENSIONS, ANCHOR EMBEDMENT, AND ADHERENCE TO THE INSTALLATION INSTRUCTIONS.
- EPOXY-GROUTED ITEMS (THREADED RODS OR REINFORCING BAR) SPECIFIED ON THE DRAWINGS SHALL BE INSTALLED USING "AT-XP" AS MANUFACTURED BY SIMPSON STRONG-TIE COMPANY. INSTALL IN STRICT ACCORDANCE WITH IAWQ REPORT NO. ER-0281. MINIMUM BASE MATERIAL TEMPERATURE IS 14 DEGREES F. RODS SHALL BE ASTM A-36 UNLESS OTHERWISE NOTED. PERIODIC SPECIAL INSPECTION OF INSTALLATION IS REQUIRED TO VERIFY ANCHOR OR EMBEDDED BAR TYPE AND DIMENSIONS, LOCATION, ADHESIVE IDENTIFICATION AND EXPIRATION, HOLE DIMENSIONS, HOLE CLEANING PROCEDURE, ANCHOR EMBEDMENT, AND ADHERENCE TO THE INSTALLATION INSTRUCTIONS. CONTINUOUS SPECIAL INSPECTION IS REQUIRED FOR HORIZONTAL AND OVERHEAD INSTALLATIONS.
- CONCRETE SCREW ANCHORS INTO CONCRETE AND CONCRETE MASONRY UNITS SHALL BE "TITEN HD" HEAVY DUTY SCREW ANCHOR AS MANUFACTURED BY THE SIMPSON STRONG-TIE COMPANY, INSTALLED IN STRICT ACCORDANCE WITH ICC-ES REPORT NO. ESR-2713 (CONCRETE), NO. ESR-1056 (CMU), INCLUDING MINIMUM EMBEDMENT REQUIREMENTS. SCREW ANCHORS INTO CONCRETE MASONRY UNITS SHALL BE INTO FULLY GROUTED CELLS. SPECIAL INSPECTION IS REQUIRED.

STEEL

- STRUCTURAL STEEL DESIGN, FABRICATION, AND ERECTION SHALL BE BASED ON:
 - AISC 360 AND SECTION 2205.2 OF THE INTERNATIONAL BUILDING CODE.
 - APRIL 14, 2010 AISC CODE OF STANDARD PRACTICE FOR STEEL BUILDINGS AND BRIDGES AMENDED AS FOLLOWS: AS NOTED IN THE CONTRACT DOCUMENTS, BY THE DELETION OF PARAGRAPH 4.4.1, AND REVISE REFERENCE FROM "STRUCTURAL DESIGN DRAWINGS" TO "CONTRACT DOCUMENTS" IN PARAGRAPH 3.1.
 - SPECIFICATION FOR STRUCTURAL JOINTS USING ASTM A325 OR A490 BOLTS.
- STRUCTURAL STEEL SHALL CONFORM TO THE FOLLOWING REQUIREMENTS:

TYPE OF MEMBER	ASTM SPECIFICATION	FY
A. WIDE FLANGE SHAPES	A992	50 KSI
B. OTHER SHAPES, PLATES, AND RODS	A36	36 KSI
C. OTHER SHAPES AND PLATES (NOTED GRADE 50 ON PLANS)	A572 (GRADE 50)	50 KSI
D. PIPE COLUMNS	A53 (E OR S, GR. B)	35 KSI
E. STRUCTURAL TUBING -SQUARE OR RECTANGULAR -ROUND	A500 (GR. B) OR ASTM A1085	46 KSI 42 KSI
F. CONNECTION BOLTS (3/4" ROUND, UNLESS SHOWN OTHERWISE)	A325-N	
- ARCHITECTURALLY EXPOSED STRUCTURAL STEEL SHALL CONFORM TO SECTION 10 OF THE AISC CODE OF STANDARD PRACTICE FOR STEEL BUILDINGS AND BRIDGES.
- ALL STEEL EXPOSED TO THE WEATHER OR IN CONTACT WITH GROUND SHALL BE CORROSION PROTECTED BY GALVANIZATION OR PROVIDED WITH EXTERIOR PAINT SYSTEM, UNLESS OTHERWISE NOTED.
- SHOP PRIME ALL STEEL EXCEPT:
 - STEEL ENCASED IN CONCRETE.
 - SURFACES TO BE WELDED.
 - CONTACT SURFACES AT HIGH-STRENGTH BOLTS.
 - MEMBERS TO BE GALVANIZED.
 - MEMBERS WHICH WILL BE CONCEALED BY INTERIOR FINISHES.
 - SURFACES TO RECEIVE SPRAYED FIREPROOFING.
 - SURFACES TO RECEIVE OTHER SPECIAL SHOP PRIMERS.
- ALL A-325N CONNECTION BOLTS NEED ONLY BE TIGHTENED TO A SNUG TIGHT CONDITION, DEFINED AS THE TIGHTNESS THAT EXISTS WHEN ALL PLIES IN A JOINT ARE IN FIRM CONTACT. THIS MAY BE ATTAINED BY A FEW IMPACTS OF AN IMPACT WRENCH OR THE FULL EFFORT OF AN IRONWORKER USING AN ORDINARY SPUD WRENCH.
- ALL ANCHORS EMBEDDED IN MASONRY OR CONCRETE SHALL BE A307 HEADED BOLTS OR A36 THREADED ROD WITH AN ASTM 563 HEAVY HEX NUT TACK WELDED ON THE EMBEDDED END.
- ALL WELDING SHALL BE IN CONFORMANCE WITH AISC AND AWS STANDARDS AND SHALL BE PERFORMED BY WABO CERTIFIED WELDERS USING E70XX ELECTRODES. ONLY PREQUALIFIED WELDS (AS DEFINED BY AWS) SHALL BE USED. ALL COMPLETE JOINT PENETRATION GROOVE WELDS SHALL BE MADE WITH A FILLER MATERIAL THAT HAS A MINIMUM CVN TOUGHNESS OF 20 FT-LBS AT -20 DEGREES F AND 40 FT - LBS AT 70 DEGREES F, AS DETERMINED BY AWS CLASSIFICATION OR MANUFACTURER CERTIFICATION.

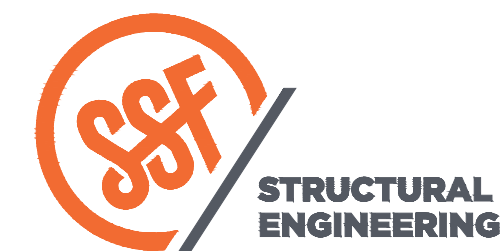

2124 Third Avenue - Suite 100 - Seattle, WA 98121
P: 206.443.6212
ssfengineers.com
934 Broadway - Tacoma, WA 98402
P: 253.284.9470
ssfengineers.com

Copyright 2019 Swenson Say Fajit - All Rights Reserved



DESIGN:	KMR
DRAWN:	NHD
CHECKED:	DJS
APPROVED:	DJS

REVISIONS:			
1	Owner/Geotech Rev.	August 3, 2019	
2	Kzt Rev.	October 1, 2019	
3	Handrail/Revisions	Feb. 5, 2020	

JURISDICTIONAL APPROVAL STAMP:

PROJECT TITLE:

Brenes Remodel

2675 74th Ave SE
Mercer Island, WA 98040

ARCHITECT:

Living Shelter Architects,
PLLC
972-A Front Street N
Issaquah, WA 98027
PH 425.427.8643

ISSUE:

PERMIT

SHEET TITLE:

**General
Structural Notes**

SCALE:

DATE: May 8, 2019

PROJECT NO: 10592-2018-01

SHEET NO:

S1.1

General Structural Notes

THE FOLLOWING APPLY UNLESS SHOWN OTHERWISE ON THE DRAWINGS

WOOD

35. FRAMING LUMBER SHALL BE S-DRY, KD, OR MC-19, AND GRADED AND MARKED IN CONFORMANCE WITH WCLIB STANDARD "GRADING RULES FOR WEST COAST LUMBER NO. 17", OR WMPA STANDARD, "WESTERN LUMBER GRADING RULES 2011". FURNISH TO THE FOLLOWING MINIMUM STANDARDS:

JOISTS AND BEAMS	(2X & 3X MEMBERS)	HEM-FIR NO. 2 MINIMUM BASE VALUE, Fb = 850 PSI
	(4X MEMBERS)	DOUGLAS FIR-LARCH NO. 1 MINIMUM BASE VALUE, Fb = 1000 PSI
BEAMS	(INCL. 6X AND LARGER)	DOUGLAS FIR-LARCH NO. 1 MINIMUM BASE VALUE, Fb = 1350 PSI
POSTS	(4X MEMBERS)	DOUGLAS FIR-LARCH NO. 2 MINIMUM BASE VALUE, Fc = 1350 PSI
	(6X AND LARGER)	DOUGLAS FIR-LARCH NO. 1 MINIMUM BASE VALUE, Fc = 1000 PSI
STUDS, PLATES & MISC. FRAMING:		DOUGLAS-FIR-LARCH OR HEM-FIR NO. 2

36. GLUED LAMINATED MEMBERS SHALL BE FABRICATED IN CONFORMANCE WITH ASTM AND ANSI/AITC STANDARDS. EACH MEMBER SHALL BEAR AN AITC OR APA-EWS IDENTIFICATION MARK AND SHALL BE ACCOMPANIED BY AN AITC OR APA-EWS CERTIFICATE OF CONFORMANCE. ALL SIMPLE SPAN BEAMS SHALL BE DOUGLAS FIR COMBINATION 24F-V4, Fb = 2,400 PSI, Fv = 265 PSI. ALL CANTILEVERED BEAMS SHALL BE DOUGLAS FIR COMBINATION 24F-V8, Fb = 2400 PSI, Fv = 265 PSI. CAMBER ALL SIMPLE SPAN GLULAM BEAMS TO 3,500' RADIUS, UNLESS SHOWN OTHERWISE ON THE PLANS.

37. MANUFACTURED LUMBER, PSL, LVL, AND LSL SHOWN ON PLAN ARE BASED PRODUCTS MANUFACTURED BY THE WEYERHAEUSER CORPORATION IN ACCORDANCE WITH ICC-ES REPORT ESR-1387. MEMBERS SHALL HAVE THE FOLLOWING MINIMUM PROPERTIES:

PSL (2.0E)	Fb = 2900 PSI,	E = 2000 KSI,	Fv = 290 PSI
LVL (2.0E)	Fb = 2600 PSI,	E = 2000 KSI,	Fv = 285 PSI
LSL (1.55E)	Fb = 2325 PSI,	E = 1550 KSI,	Fv = 310 PSI

ALTERNATE MANUFACTURED LUMBER MANUFACTURERS MAY BE USED SUBJECT TO REVIEW AND APPROVAL BY THE ARCHITECT AND STRUCTURAL ENGINEER. ALTERNATE MANUFACTURER'S PRODUCTS SHALL BE COMPATIBLE WITH THE JOIST HANGERS AND OTHER HARDWARE SPECIFIED ON PLANS, OR ALTERNATE HANGERS AND HARDWARE SHALL SUBMITTED FOR REVIEW AND APPROVAL. SUBSTITUTED ITEMS SHALL HAVE ICC-ES REPORT APPROVAL FOR EQUAL OR GREATER LOAD CAPACITIES.

MANUFACTURED LUMBER PRODUCTS SHALL BE INSTALLED WITH A MOISTURE CONTENT OF 12% OR LESS. THE CONTRACTOR SHALL MAKE PROVISIONS DURING CONSTRUCTION TO PREVENT THE MOISTURE CONTENT OF INSTALLED BEAMS FROM EXCEEDING 12%. EXCESSIVE DEFLECTIONS MAY OCCUR IF MOISTURE CONTENT EXCEEDS THIS VALUE.

38. PLYWOOD SHEATHING SHALL BE GRADE C-D, EXTERIOR GLUE OR STRUCTURAL II, EXTERIOR GLUE IN CONFORMANCE WITH DOC PS 1 OR PS 2. ORIENTED STRAND BOARD OF EQUIVALENT THICKNESS, EXPOSURE RATING AND PANEL INDEX MAY BE USED IN LIEU OF PLYWOOD.

ROOF SHEATHING SHALL BE 1/2" (NOMINAL) WITH SPAN RATING 32/16.

FLOOR SHEATHING SHALL BE 3/4" (NOMINAL) WITH SPAN RATING 48/24.

WALL SHEATHING SHALL BE 1/2" (NOMINAL) WITH SPAN RATING 24/0.

PROVIDE APPROVED PLYWOOD EDGE CLIPS CENTERED BETWEEN JOISTS/TRUSSES AT UNBLOCKED ROOF SHEATHING EDGES. ALL FLOOR SHEATHING EDGES SHALL HAVE APPROVED T&G JOINTS OR SHALL BE SUPPORTED WITH SOLID BLOCKING. ALLOW 1/8" SPACING AT ALL PANEL EDGES AND ENDS OF FLOOR AND ROOF SHEATHING.

REFER TO WOOD FRAMING NOTES BELOW FOR TYPICAL NAILING REQUIREMENTS.

39. ALL WOOD IN DIRECT CONTACT WITH CONCRETE OR MASONRY SHALL BE PRESSURE-TREATED WITH AN APPROVED PRESERVATIVE OR (2) LAYERS OF ASPHALT IMPREGNATED BUILDING PAPER SHALL BE PROVIDED BETWEEN UNTREATED WOOD AND CONCRETE OR MASONRY.

40. PRESERVATIVE TREATED WOOD SHALL BE TREATED PER WMPA STANDARD U1 TO THE USE CATEGORY EQUAL TO OR HIGHER THAN THE INTENDED APPLICATION. TREATED WOOD FOR ABOVE GROUND USE SHALL BE TREATED TO WMPA UC3B. WOOD IN CONTINUOUS CONTACT WITH FRESH WATER OR SOIL SHALL BE TREATED TO WMPA UC4A. WOOD FOR USE IN PERMANENT FOUNDATIONS SHALL BE TREATED TO WMPA UC4B.

41. WOOD TREATED FOR FIRE RESISTANCE SHALL MEET THE REQUIREMENTS OF ASTM E 84 OR UL 723 AND HAVE A LISTED FLAME SPREAD INDEX OF 25 OR LESS. FIRE RETARDANT TREATED LUMBER AND WOOD STRUCTURAL PANELS SHALL BE LABELED IN ACCORDANCE WITH IBC 2303.2.4. WOOD TREATED FOR FIRE PROTECTION FOR USE IN INTERIOR ABOVE GROUND CONSTRUCTION AND CONTINUOUSLY PROTECTED FROM WEATHER AND OTHER SOURCES OF MOISTURE SHALL BE TREATED TO WMPA UCFA. WOOD TREATED FOR FIRE PROTECTION FOR USE IN EXTERIOR ABOVE GROUND CONSTRUCTION AND SUBJECT TO WETTING OR OTHER SOURCES OF MOISTURE SHALL BE TREATED TO WMPA UCFB.

42. FASTENERS AND TIMBER CONNECTORS USED WITH TREATED WOOD SHALL HAVE CORROSION RESISTANCE AS INDICATED IN THE FOLLOWING TABLE, UNLESS OTHERWISE NOTED.

WOOD TREATMENT	CONDITION	PROTECTION
HAS NO AMMONIA CARRIER	INTERIOR DRY	G90 GALVANIZED
CONTAINS AMMONIA CARRIER	INTERIOR DRY	G185 OR A185 HOT DIPPED OR CONTINUOUS HOT-GALVANIZED PER ASTM A653
CONTAINS AMMONIA CARRIER	INTERIOR WET	TYPE 304 OR 316 STAINLESS
CONTAINS AMMONIA CARRIER	EXTERIOR	TYPE 304 OR 316 STAINLESS
AZCA	ANY	TYPE 304 OR 316 STAINLESS

INTERIOR DRY CONDITIONS SHALL HAVE WOOD MOISTURE CONTENT LESS THAN 19%. WOOD MOISTURE CONTENT IN OTHER CONDITIONS (INTERIOR WET, EXTERIOR WET, AND EXTERIOR DRY) IS EXPECTED TO EXCEED 19%. CONNECTORS AND THEIR FASTENERS SHALL BE THE SAME MATERIAL, COMPLY WITH THE TREATMENT MANUFACTURERS RECOMMENDATIONS FOR PROTECTION OF METAL.

43. TIMBER CONNECTORS CALLED OUT BY LETTERS AND NUMBERS SHALL BE "STRONG-TIE" BY SIMPSON COMPANY, AS SPECIFIED IN THEIR CATALOG NUMBER C-C-2019. EQUIVALENT DEVICES BY OTHER MANUFACTURERS MAY BE SUBSTITUTED, PROVIDED THEY HAVE ICC-ES APPROVAL FOR EQUAL OR GREATER LOAD CAPACITIES. PROVIDE NUMBER AND SIZE OF FASTENERS AS SPECIFIED BY MANUFACTURER FOR MAXIMUM LOAD CARRYING CAPACITY. CONNECTORS SHALL BE INSTALLED IN ACCORDANCE WITH THE MANUFACTURER'S RECOMMENDATIONS.

ALL 2X JOISTS SHALL BE CONNECTED TO FLUSH BEAMS WITH "LUS" SERIES JOIST HANGERS. ALL TJI JOISTS SHALL BE CONNECTED TO FLUSH BEAMS WITH "ITS" SERIES JOIST HANGERS. ALL DOUBLE-JOIST BEAMS SHALL BE CONNECTED TO FLUSH BEAMS WITH "MIT" SERIES JOIST HANGERS.

WHERE CONNECTOR STRAPS CONNECT TWO MEMBERS, PLACE ONE-HALF OF THE NAILS OR BOLTS IN EACH MEMBER.

ALL SHIMS SHALL BE SEASONED AND DRIED AND THE SAME GRADE (MINIMUM) AS MEMBERS CONNECTED.

44. WOOD FASTENERS

A. NAIL SIZES SPECIFIED ON DRAWINGS ARE BASED ON THE FOLLOWING SPECIFICATIONS:

SIZE	LENGTH	DIAMETER
8d	2-1/2"	0.131"
16d BOX	3-1/2"	0.135"

IF CONTRACTOR PROPOSES THE USE OF ALTERNATE NAILS, THEY SHALL SUBMIT NAIL SPECIFICATIONS TO THE STRUCTURAL ENGINEER (PRIOR TO CONSTRUCTION) FOR REVIEW AND APPROVAL.

NAILS - PLYWOOD (APA RATED SHEATHING) FASTENERS TO FRAMING SHALL BE DRIVEN FLUSH TO FACE OF SHEATHING WITH NO COUNTERSINKING PERMITTED. TOE-NAILS SHALL BE DRIVEN AT AN ANGLE OF 30 DEGREES WITH THE MEMBER AND STARTED 1/3 THE LENGTH OF THE NAIL FROM THE MEMBER END.

B. ALL BOLTS IN WOOD MEMBERS SHALL CONFORM TO ASTM A307. PROVIDE WASHERS UNDER THE HEADS AND NUTS OF ALL BOLTS AND LAG BOLTS BEARING ON WOOD. INSTALLATION OF LAG BOLTS SHALL CONFORM TO THE NATIONAL DESIGN SPECIFICATION FOR WOOD CONSTRUCTION WITH A LEAD BORE HOLE OF 60 TO 70 PERCENT OF THE SHANK DIAMETER. LEAD HOLES ARE NOT REQUIRED FOR 3/8" AND SMALLER LAG SCREWS.

45. NOTCHES AND HOLES IN WOOD FRAMING:

A. NOTCHES ON THE ENDS OF SOLID SAWN JOISTS AND RAFTERS SHALL NOT EXCEED ONE-FOURTH THE JOIST DEPTH. NOTCHES IN THE TOP OR BOTTOM OF SOLID SAWN JOISTS SHALL NOT EXCEED ONE-SIXTH THE DEPTH AND SHALL NOT BE LOCATED IN THE MIDDLE THIRD OF THE SPAN. HOLES BORED IN SOLID SAWN JOISTS AND RAFTERS SHALL NOT BE WITHIN 2 INCHES OF THE TOP OR BOTTOM OF THE JOIST, AND THE DIAMETER OF ANY SUCH HOLE SHALL NOT EXCEED ONE-THIRD THE DEPTH OF THE JOIST.

B. IN EXTERIOR WALLS AND BEARING PARTITIONS, ANY WOOD STUD IS PERMITTED TO BE CUT OR NOTCHED TO A DEPTH NOT EXCEEDING 25 PERCENT OF ITS WIDTH. A HOLE NOT GREATER IN DIAMETER THAN 40 PERCENT OF THE STUD WIDTH IS PERMITTED TO BE BORED IN ANY WOOD STUD. IN NO CASE SHALL THE EDGE OF THE BORED HOLE BE NEARER THAN 5/8 INCH TO THE EDGE OF THE STUD. BORED HOLES SHALL NOT BE LOCATED AT THE SAME SECTION OF STUD AS A CUT OR NOTCH.

C. NOTCHES AND HOLES IN MANUFACTURED LUMBER AND PREFABRICATED PLYWOOD WEB JOISTS SHALL BE PER THE MANUFACTURERS RECOMMENDATIONS UNLESS OTHERWISE NOTED.

46. WOOD FRAMING NOTES--THE FOLLOWING APPLY UNLESS OTHERWISE SHOWN ON THE PLANS:

A. ALL WOOD FRAMING DETAILS NOT SHOWN OTHERWISE SHALL BE CONSTRUCTED TO THE MINIMUM STANDARDS OF THE INTERNATIONAL BUILDING CODE, THE AITC "TIMBER CONSTRUCTION MANUAL" AND THE AF&PA "NATIONAL DESIGN SPECIFICATION FOR WOOD CONSTRUCTION". MINIMUM NAILING, UNLESS OTHERWISE NOTED, SHALL CONFORM TO IBC TABLE 2304.10.1. COORDINATE THE SIZE AND LOCATION OF ALL OPENINGS WITH MECHANICAL AND ARCHITECTURAL DRAWINGS.

B. WALL FRAMING: REFER ARCHITECTURAL DRAWINGS FOR THE SIZE OF ALL WALLS. ALL STUDS SHALL BE SPACED AT 16" O.C. UNO. TWO STUDS MINIMUM SHALL BE PROVIDED AT THE END OF ALL WALLS AND AT EACH SIDE OF ALL OPENINGS, AND AT BEAM OR HEADER BEARING LOCATIONS. TWO 2x8 HEADERS SHALL BE PROVIDED OVER ALL OPENINGS NOT OTHERWISE NOTED. SOLID BLOCKING FOR WOOD COLUMNS SHALL BE PROVIDED THROUGH FLOORS TO SUPPORTS BELOW. PROVIDE CONTINUOUS SOLID BLOCKING AT MID-HEIGHT OF ALL STUD WALLS OVER 10'-0" IN HEIGHT.

ALL WALLS SHALL HAVE A SINGLE BOTTOM PLATE AND A DOUBLE TOP PLATE. END NAIL TOP PLATE TO EACH STUD WITH TWO 16d NAILS, AND TOENAIL OR END NAIL EACH STUD TO BOTTOM PLATE WITH TWO 16d NAILS. FACE NAIL DOUBLE TOP PLATE WITH 16d @ 12" O.C. AND LAP MINIMUM 4'-0" AT JOINTS AND PROVIDE EIGHT 16d NAILS @ 4" O.C. EACH SIDE JOINT.

ALL STUD WALLS SHALL HAVE THEIR LOWER WOOD PLATES ATTACHED TO WOOD FRAMING BELOW WITH TWO ROWS OF 16d NAILS @ 12" ON-CENTER, OR ATTACHED TO CONCRETE BELOW WITH 5/8" DIAMETER ANCHOR BOLTS @ 4'-0" ON-CENTER EMBEDDED 7" MINIMUM, UNLESS INDICATED OTHERWISE. INDIVIDUAL MEMBERS OF BUILT-UP POSTS SHALL BE NAILED TO EACH OTHER WITH TWO ROWS OF 16d @ 12" ON-CENTER. UNLESS OTHERWISE NOTED, GYPSUM WALLBOARD SHALL BE FASTENED TO THE INTERIOR SURFACE OF ALL STUDS AND PLATES WITH NO. 6 X 1-1/4" TYPE S OR W SCREWS @ 8" ON-CENTER. UNLESS INDICATED OTHERWISE, 1/2" (NOMINAL) APA RATED SHEATHING (SPAN RATING 24/0) SHALL BE NAILED TO ALL EXTERIOR SURFACES WITH 8d NAILS @ 6" ON-CENTER AT PANEL EDGES AND TOP AND BOTTOM PLATES (BLOCK UN-SUPPORTED EDGES) AND TO ALL INTERMEDIATE STUDS AND BLOCKING WITH 8d NAILS @ 12" ON-CENTER ALLOW 1/8" SPACING AT ALL PANEL EDGES AND PANEL ENDS.

C. FLOOR AND ROOF FRAMING: PROVIDE DOUBLE JOISTS UNDER ALL PARALLEL PARTITIONS THAT EXTEND OVER MORE THAN HALF THE JOIST LENGTH AND AROUND ALL OPENINGS IN FLOORS OR ROOFS UNLESS OTHERWISE NOTED. PROVIDE SOLID BLOCKING AT ALL BEARING POINTS. TOE-NAIL JOISTS TO SUPPORTS WITH TWO 16d NAILS. ATTACH TIMBER JOISTS TO FLUSH HEADERS OR BEAMS WITH SIMPSON METAL JOIST HANGERS IN ACCORDANCE WITH NOTES ABOVE. NAIL ALL MULTI JOIST BEAMS TOGETHER WITH TWO ROWS 16d @ 12" ON-CENTER.

UNLESS OTHERWISE NOTED ON THE PLANS, PLYWOOD ROOF AND FLOOR SHEATHING SHALL BE LAID UP WITH GRAIN PERPENDICULAR TO SUPPORTS AND NAILED AT 6" ON-CENTER WITH 8d NAILS TO FRAMED PANEL EDGES, STRUTS AND OVER STUD WALLS AS SHOWN ON PLANS AND @ 12" ON-CENTER TO INTERMEDIATE SUPPORTS. PROVIDE APPROVED PLYWOOD EDGE CLIPS CENTERED BETWEEN JOISTS/TRUSSES AT UNBLOCKED ROOF SHEATHING EDGES. ALL FLOOR SHEATHING EDGES SHALL HAVE APPROVED T&G JOINTS OR SHALL BE SUPPORTED WITH SOLID BLOCKING. ALLOW 1/8" SPACING AT ALL PANEL EDGES AND ENDS OF FLOOR AND ROOF SHEATHING. TOENAIL BLOCKING TO SUPPORTS WITH 16d @ 12" ON-CENTER UNLESS OTHERWISE NOTED.

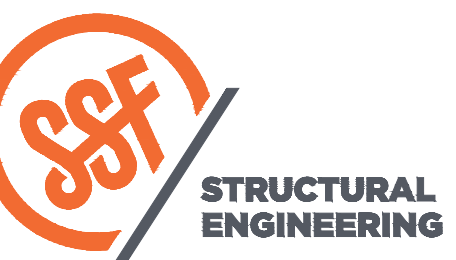

2124 Third Avenue - Suite 100 - Seattle, WA 98121
P: 206.443.6212
ssfengineers.com

934 Broadway - Tacoma, WA 98402
P: 253.284.9470
ssfengineers.com

Copyright 2019 Swenson Say Fagitt - All Rights Reserved

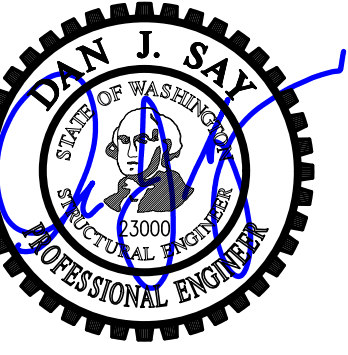

DESIGN:	KMR
DRAWN:	NHD
CHECKED:	DJS
APPROVED:	DJS

REVISIONS:		
1	Owner/Geotech Rev.	August 3, 2019
2	Kzt Rev.	October 1, 2019
3	Handrail/Revisions	Feb. 5, 2020

JURISDICTIONAL APPROVAL STAMP:

PROJECT TITLE:

Brenes Remodel

2675 74th Ave SE
Mercer Island, WA 98040

ARCHITECT:
Living Shelter Architects,
PLLC
972-A Front Street N
Issaquah, WA 98027
PH 425.427.8643

ISSUE:

PERMIT

SHEET TITLE:

**General
Structural Notes**

SCALE:

DATE: May 8, 2019

PROJECT NO: 10592-2018-01

SHEET NO:

S1.2



DESIGN:	KMR
DRAWN:	NHD
CHECKED:	DJS
APPROVED:	DJS

REVISIONS:	
1	Owner/Geotech Rev. August 3, 2019
2	Kzt Rev. October 1, 2019
3	Handrail/Revisions Feb. 5, 2020

JURISDICTIONAL APPROVAL STAMP:

PROJECT TITLE:
Brenes Remodel
 2675 74th Ave SE
 Mercer Island, WA 98040

ARCHITECT:
Living Shelter Architects, PLLC
 972-A Front Street N
 Issaquah, WA 98027
 PH 425.427.8643

ISSUE:
PERMIT

SHEET TITLE:
**Main Floor Framing/
 Foundation Plan**

SCALE:
 = 1'-0" U.N.O.
 DATE:
 May 8, 2019
 PROJECT NO:
 10592-2018-01
 SHEET NO:

S2.1

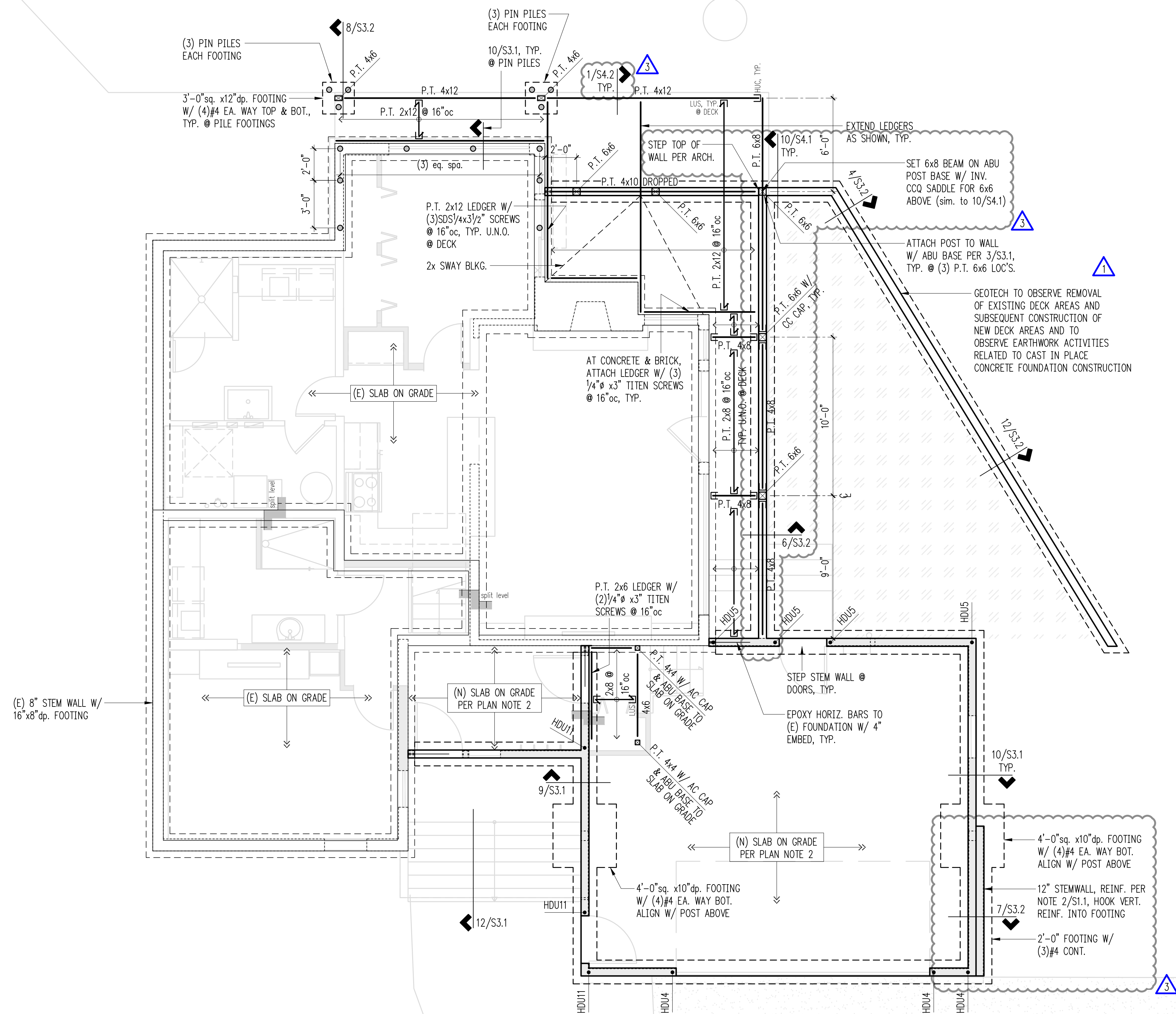

Pin Pile Plan Notes

- INSTALL 2" DIAMETER SCHEDULE 80 "X-STRONG" GALVANIZED PIPE IN SHOWN LOCATIONS PER THE GEOTECHNICAL ENGINEER, (EARTH SOLUTIONS NW, LLC).
- ALL PIN-PILES SHALL BE DRIVEN TO REFUSAL AS DEFINED IN THE GEOTECHNICAL ENGINEER. 1" OF PENETRATION DURING 60 SECONDS OF CONTINUOUS DRIVING WITH STANDARD 90-POUND JACKHAMMER.
- ALL STRUCTURAL FILL OR BACKFILL ADJACENT TO FOOTINGS SHALL BE COMPACTED IN LOOSE LIFTS NOT EXCEEDING 12 INCHES PER THE GEOTECHNICAL ENGINEER.
- MINIMUM DEPTH OF FOOTINGS SUPPORTED BY PIN-PILE 1'-0".
- MINIMUM SPACING FOR PILES IN GROUP 12".
- SEE SHEET S3.1, S3.2 AND GEOTECHNICAL REPORT FOR ADDITIONAL NOTES AND DETAILS.

Legend

- (E) STRUCTURAL WALL OR POST ABOVE
- NEW STRUCTURAL WALL OR POST ABOVE
- EXISTING STEM WALL & FOOTING
- NEW STEM WALL & FOOTING
- SPAN DIRECTION
- EXTENT OF JOISTS
- EXISTING HEADER/BEAM
- NEW HEADER/BEAM PER PLAN
- HANGER
- CHANGE IN ELEVATION
- XX HOLDOWN PER 6/S3.1
- 2" PIN PILE PER PLAN & GENERAL STRUCTURAL NOTES. REFER DETAIL 10/S3.2

Plan Notes

- THE BOTTOM OF ALL NEW EXTERIOR FOOTINGS SHALL BE 18" MINIMUM BELOW GRADE.
- TYPICAL NEW SLABS SHALL BE 4" MINIMUM THICKNESS. REINFORCE WITH #3 @ 16" O.C. EACH WAY CENTERED IN SLAB. PROVIDE 6 MIL VAPOR BARRIER BELOW SLAB OVER 4" MINIMUM FREE DRAINING GRAVEL OVER FIRM NATIVE SOILS. VAPOR BARRIER MAY BE OMITTED AT EXTERIOR.
- PROVIDE CORNER BARS PER DETAIL S3.1 AT ALL NEW WALL AND FOOTING INTERSECTIONS.
- STEP FOOTINGS AS REQUIRED TO ACCOMMODATE CHANGES IN GRADE PER DETAIL S3.1.
- ALL POST ABOVE SHALL BEAR FULLY ON BEAMS OR POST BELOW AND SHALL HAVE CONTINUOUS FULL BEARING THROUGH FLOORS TO THE FOUNDATION.
- ALL NEW EXTERIOR WALLS SHALL BE W6 UNLESS NOTED OTHERWISE.
- 5/8" DIAMETER A.B. SPACED PER SHEARWALL SCHEDULE BASE PLATE CONNECTION.
- CONFIRM EXISTING FOUNDATION AND CONCRETE IS FREE FROM CRACKS AND SPALLING.
- DO NOT SCALE THE DRAWINGS REFER TO ARCHITECTURAL DRAWINGS FOR DIMENSIONS.
- REFER GENERAL STRUCTURAL NOTES FOR ADDITIONAL REQUIREMENTS.

Main Floor Framing/Foundation Plan
 Scale: 1/4" = 1'-0"



DESIGN:	KMR
DRAWN:	NHD
CHECKED:	DJS
APPROVED:	DJS

REVISIONS:	
1	Owner/Geotech Rev. August 3, 2019
2	Kzt Rev. October 1, 2019
3	Handrail/Revisions Feb. 5, 2020

JURISDICTIONAL APPROVAL STAMP:

PROJECT TITLE:
Brenes Remodel
2675 74th Ave SE
Mercer Island, WA 98040

ARCHITECT:
Living Shelter Architects, PLLC
972-A Front Street N
Issaquah, WA 98027
PH 425.427.8643

ISSUE:
PERMIT

SHEET TITLE:
Upper Floor Framing Plan

SCALE:
= 1'-0" U.N.O.

DATE:
May 8, 2019

PROJECT NO:
10592-2018-01

SHEET NO:

S2.2

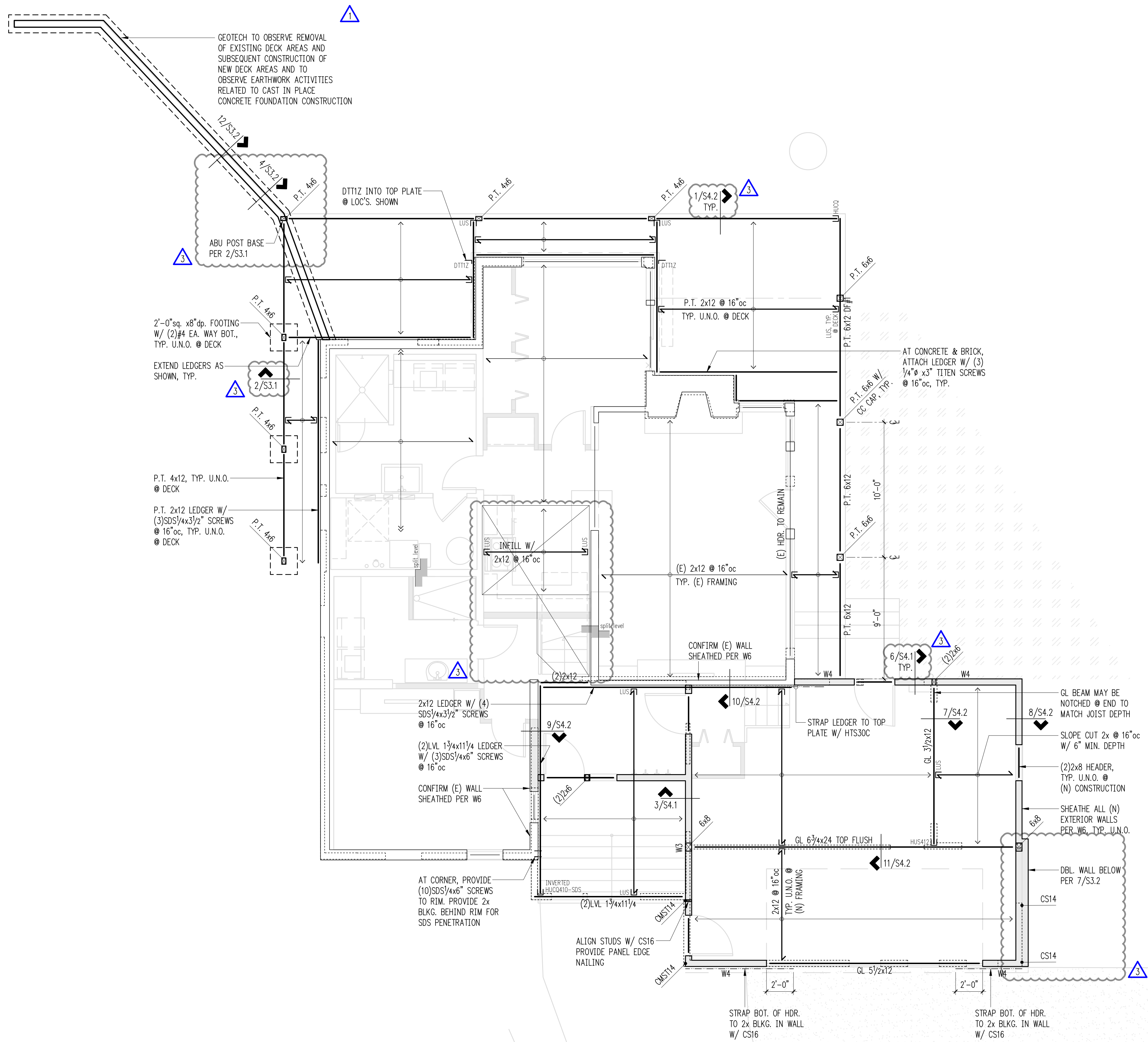

Legend

- (E) STRUCTURAL WALL OR POST ABOVE
- NEW STRUCTURAL WALL OR POST ABOVE
- EXISTING STRUCTURAL WALL BELOW
- NEW STRUCTURAL WALL BELOW
- NON-STRUCTURAL WALL BELOW
- SHEARWALL PER 12/S4.1
- SPAN DIRECTION
- EXTENT OF JOISTS
- EXISTING HEADER/BEAM
- NEW HEADER/BEAM PER PLAN
- HANGER
- CHANGE IN ELEVATION

Plan Notes

1. TYPICAL NEW FLOOR FRAMING CONSISTS 3/4" T&G PLYWOOD, FACE GRAIN PERPENDICULAR TO SUPPORTS OVER 2X FRAMING PER PLAN. NAIL SHEATHING WITH 8D AT 6" O.C. EDGES, 12" O.C. FIELD.
2. HEADERS SHALL BE PER PLAN.
3. PROVIDE (2) BEARING STUDS EACH END OF ALL HEADERS AND BEAMS OVER 6'-0" IN LENGTH, UNLESS NOTED OTHERWISE.
4. ALL NEW EXTERIOR WALLS SHALL BE W6 UNLESS NOTED OTHERWISE.
5. PROVIDE AC, ACE, LPC, OR LCE COLUMN CAP AT ALL BEAM TO COLUMN CONNECTIONS. REFER GENERAL STRUCTURAL NOTES FOR ADDITIONAL REQUIREMENTS.
6. DO NOT SCALE THE DRAWINGS REFER TO ARCHITECTURAL PLANS FOR ALL DIMENSIONS.

Upper Floor Framing Plan
Scale: 1/4" = 1'-0"



DESIGN: KMR
 DRAWN: NHD
 CHECKED: DJS
 APPROVED: DJS

NO.	REVISIONS	DATE
1	Owner/Geotech Rev.	August 3, 2019
2	Kzt Rev.	October 1, 2019
3	Handrail/Revisions	Feb. 5, 2020

JURISDICTIONAL APPROVAL STAMP:

PROJECT TITLE:
Brenes Remodel
 2675 74th Ave SE
 Mercer Island, WA 98040

ARCHITECT:
Living Shelter Architects, PLLC
 972-A Front Street N
 Issaquah, WA 98027
 PH 425.427.8643

ISSUE:
PERMIT

SHEET TITLE:
Roof Framing Plan

SCALE: 1/4" = 1'-0" U.N.O.
 DATE: May 8, 2019
 PROJECT NO: 10592-2018-01
 SHEET NO:

S2.3

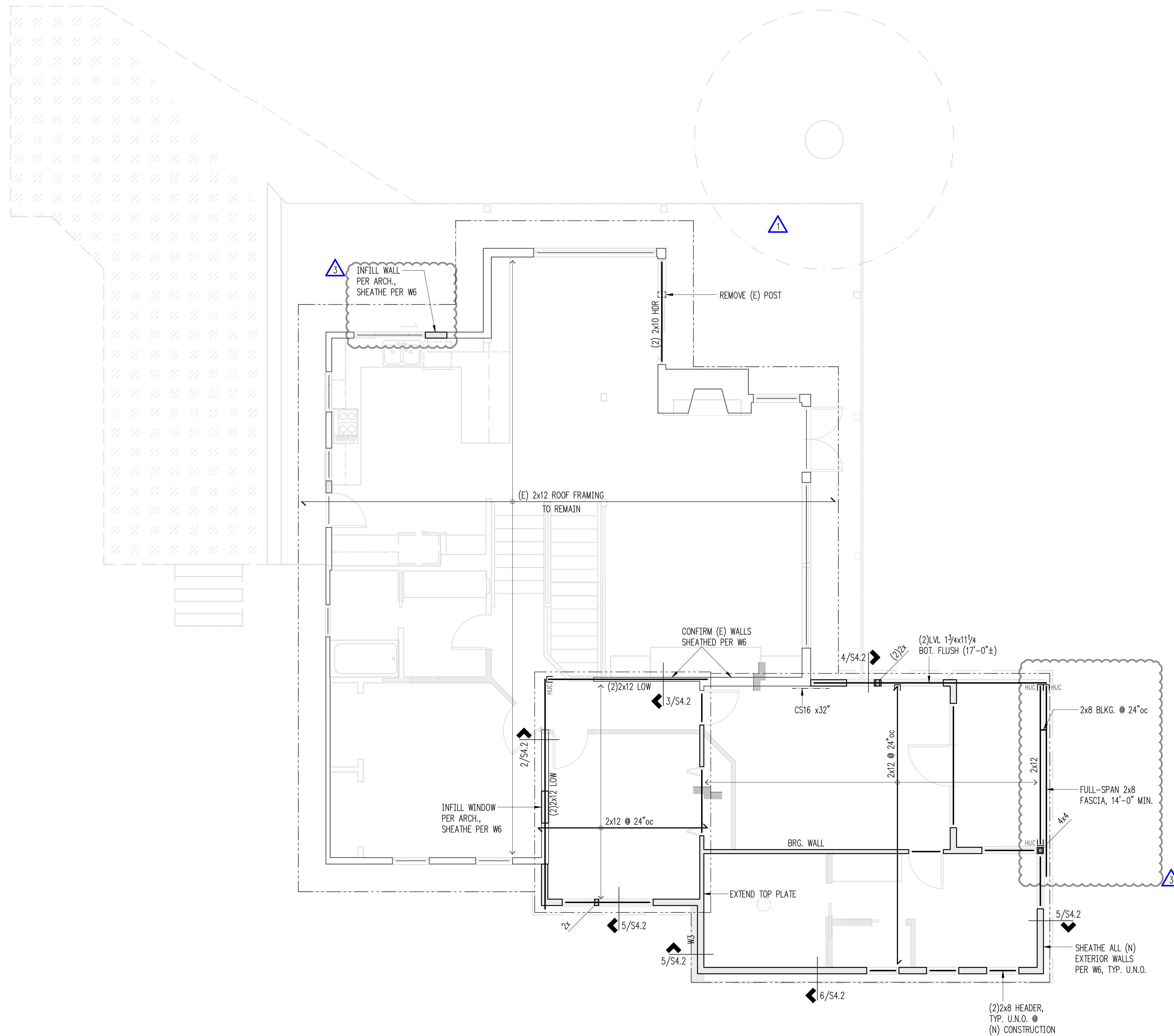

Legend

- EXISTING STRUCTURAL WALL BELOW
- NEW STRUCTURAL WALL BELOW
- NON-STRUCTURAL WALL BELOW
- SHEARWALL PER 12/S4.1
- SPAN DIRECTION
- EXTENT OF JOISTS
- EXISTING HEADER/BEAM
- NEW HEADER/BEAM PER PLAN
- HANGER
- CHANGE IN ELEVATION

Plan Notes

1. TYPICAL ROOF FRAMING CONSISTS OF 1/2" CDX PLYWOOD, FACE GRAIN PERPENDICULAR TO SUPPORTS OVER ROOF FRAMING PER PLAN. NAIL SHEATHING WITH 8D AT 6" O.C. EDGES, 12" O.C. FIELD.
2. PROVIDE H1 HURRICANE TIE EACH END OF ALL ROOF RAFTERS.
3. HEADERS SHALL BE PER PLAN
4. PROVIDE (2) BEARING STUDS EACH END OF ALL HEADERS AND BEAMS OVER 6'-0" IN LENGTH, UNLESS NOTED OTHERWISE.
5. ALL NEW EXTERIOR WALLS SHALL BE W6 UNLESS NOTED OTHERWISE.
6. PROVIDE AC, ACE, LPC, OR LCE COLUMN CAP AT ALL BEAM TO COLUMN CONNECTIONS.
7. REFER TO GENERAL STRUCTURAL NOTES FOR ADDITIONAL REQUIREMENTS.

Roof Framing Plan
 Scale: 1/4" = 1'-0"



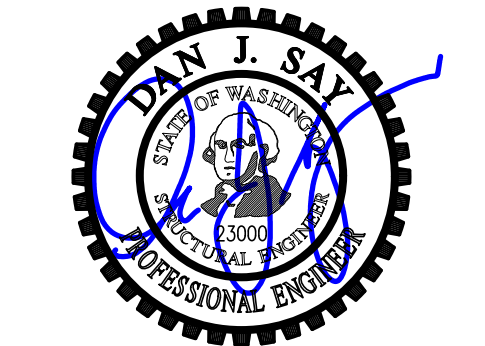

DESIGN: KMR
 DRAWN: NHD
 CHECKED: DJS
 APPROVED: DJS

REVISIONS:

1	Owner/Geotech Rev.	August 3, 2019
2	Kzt Rev.	October 1, 2019
3	Handrail/Revisions	Feb. 5, 2020

JURISDICTIONAL APPROVAL STAMP:

PROJECT TITLE:
Brenes Remodel
 2675 74th Ave SE
 Mercer Island, WA 98040

ARCHITECT:
Living Shelter Architects, PLLC
 972-A Front Street N
 Issaquah, WA 98027
 PH 425.427.8643

ISSUE:
PERMIT

SHEET TITLE:
Foundation Details
 SCALE: 3/4" = 1'-0" U.N.O.
 DATE: May 8, 2019
 PROJECT NO: 10592-2018-01
 SHEET NO:

1

2

3

4

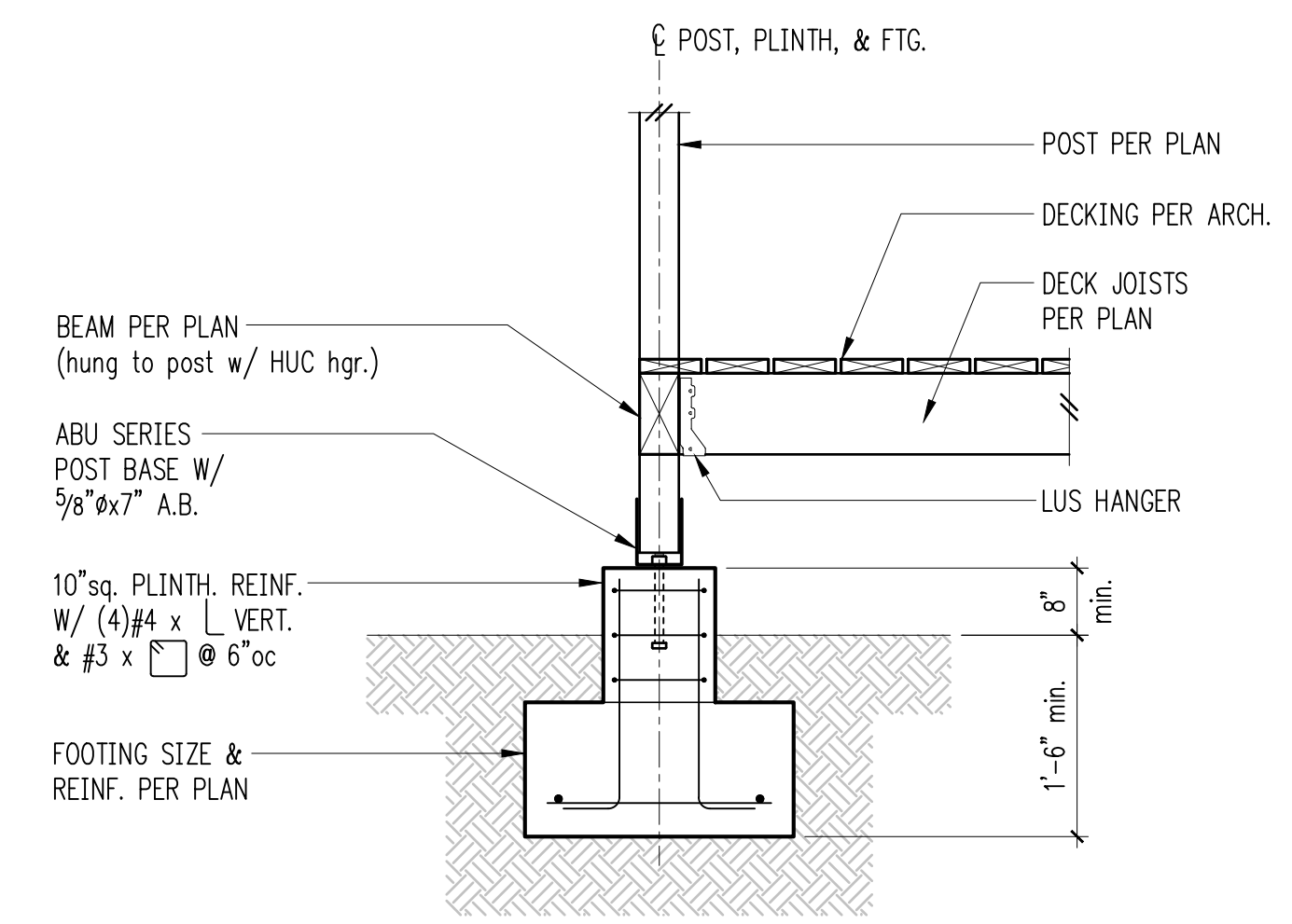

Typical Deck Detail

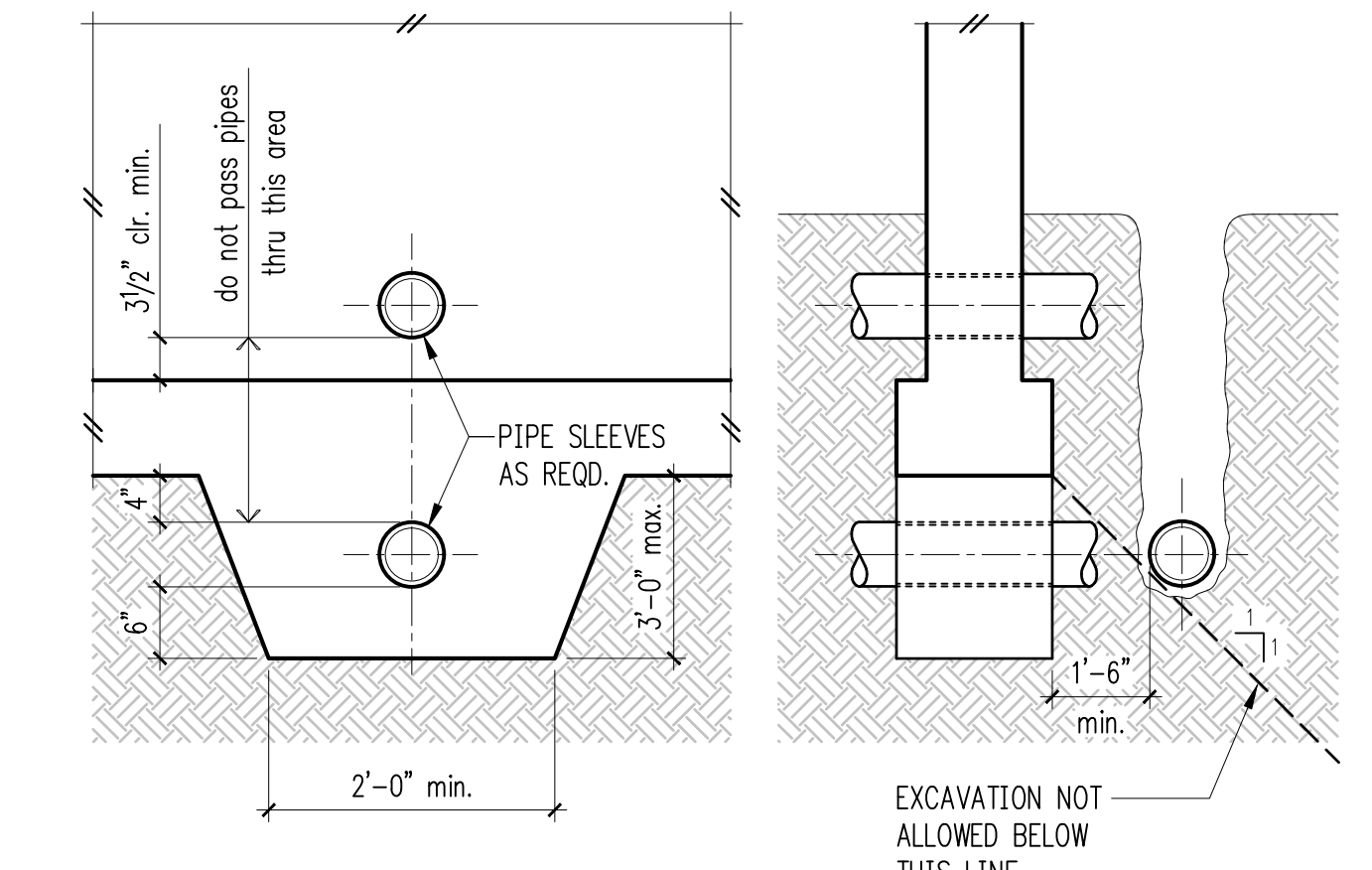

Pipe and Trench Locations

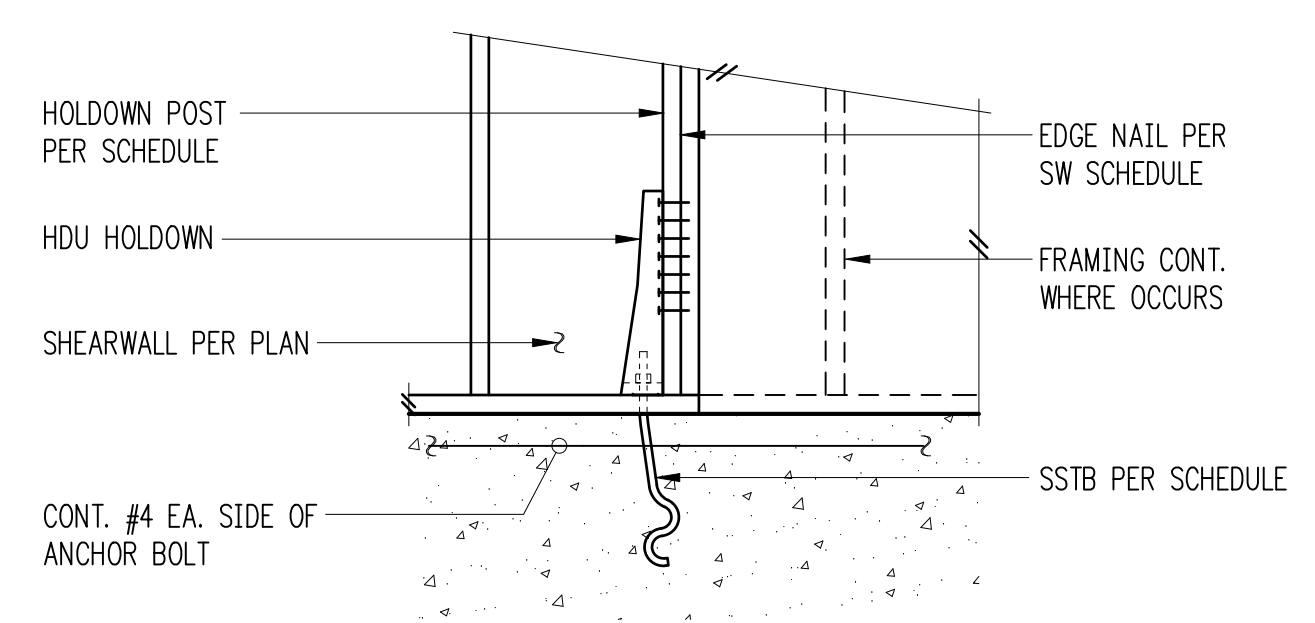
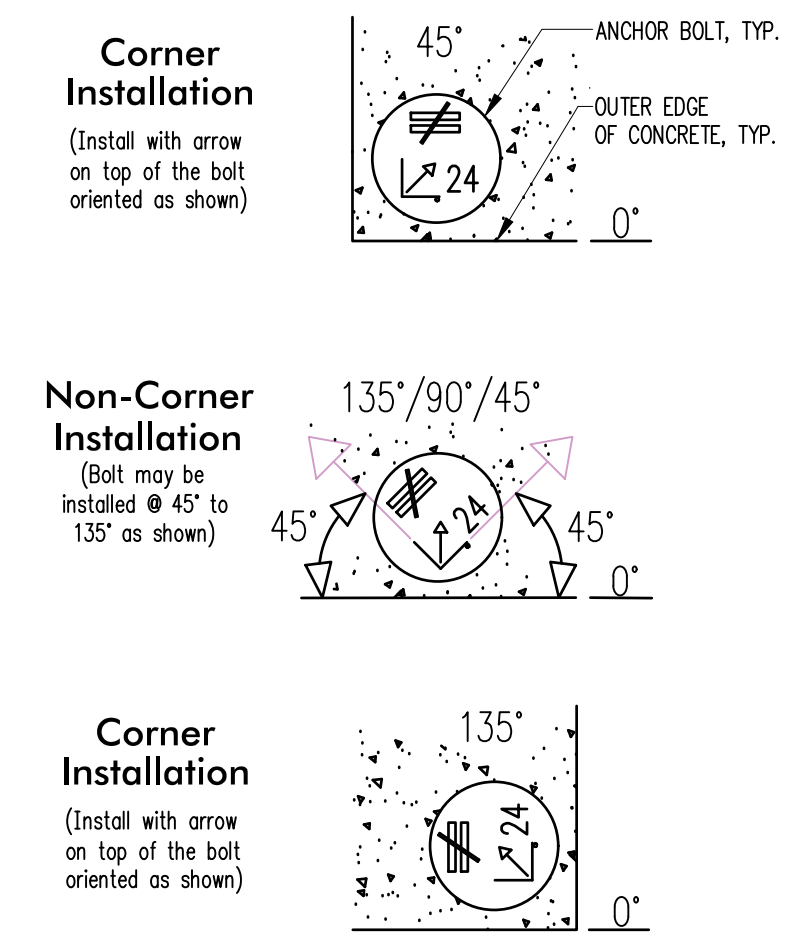

Holdown Schedule

Plan Mark	Screws	Anchor Bolt	A.B. Embed	Holdown Post ① if 2x4	if 2x6
HDU2-SDS2.5	(6)SDS 1/4"x2 1/2"	SSTB20	16 7/8"	(2) 2x4	(2) 2x6
HDU4-SDS2.5	(10)SDS 1/4"x2 1/2"	SB5/8x24	18"	4x4	4x6
HDU5-SDS2.5	(14)SDS 1/4"x2 1/2"	SB5/8x24	18"	4x4	4x6
HDU11-SDS2.5	(30)SDS 1/4"x2 1/2"	SB1x30	24"	4x8	6x6

① MINIMUM SIZE OF POST AT END OF WALL UNLESS OTHERWISE NOTED ON FRAMING PLANS.

Typical HDU Holdown

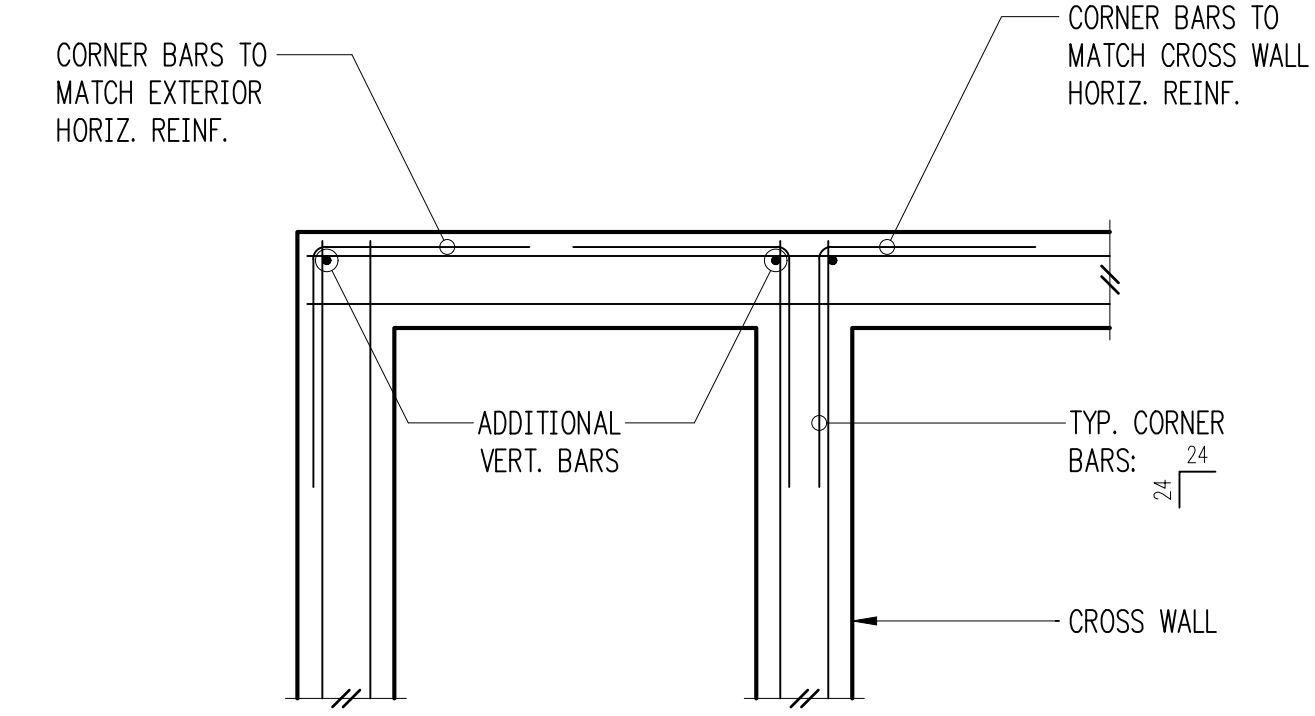

Double Curtain

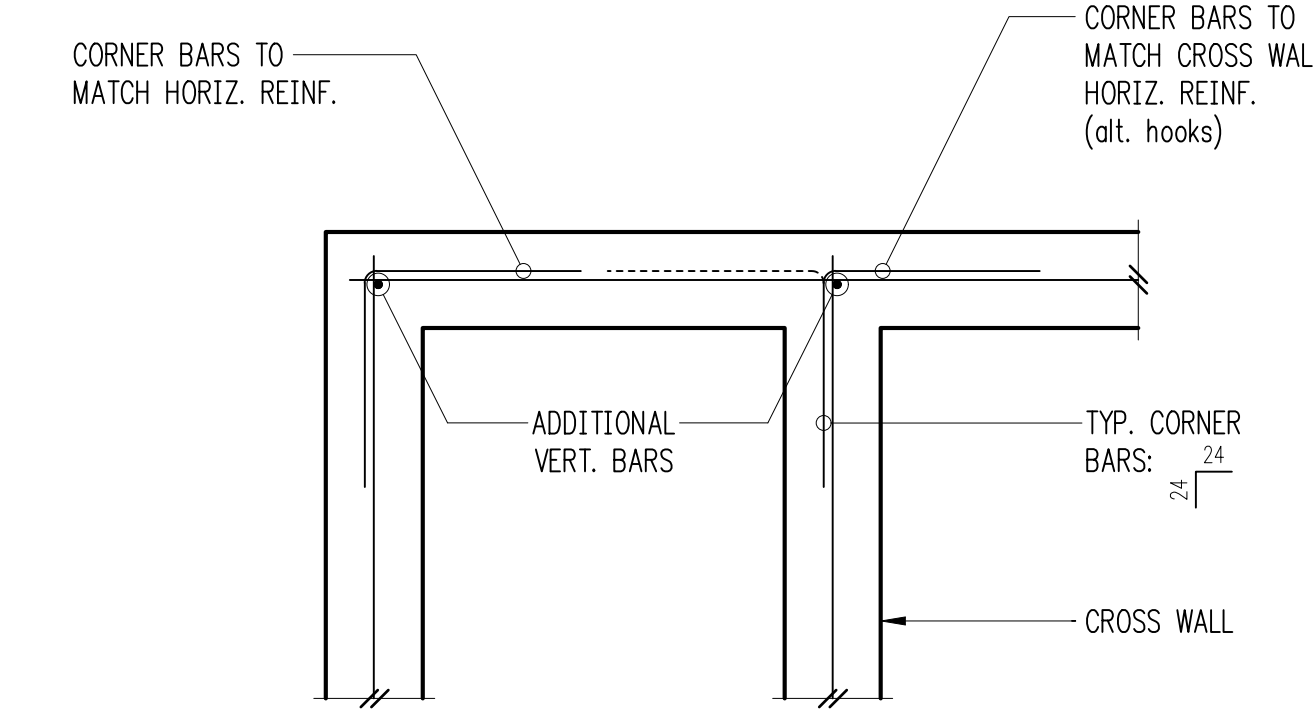

Single Curtain

Typical Corner Bars at Concrete Walls and Footings

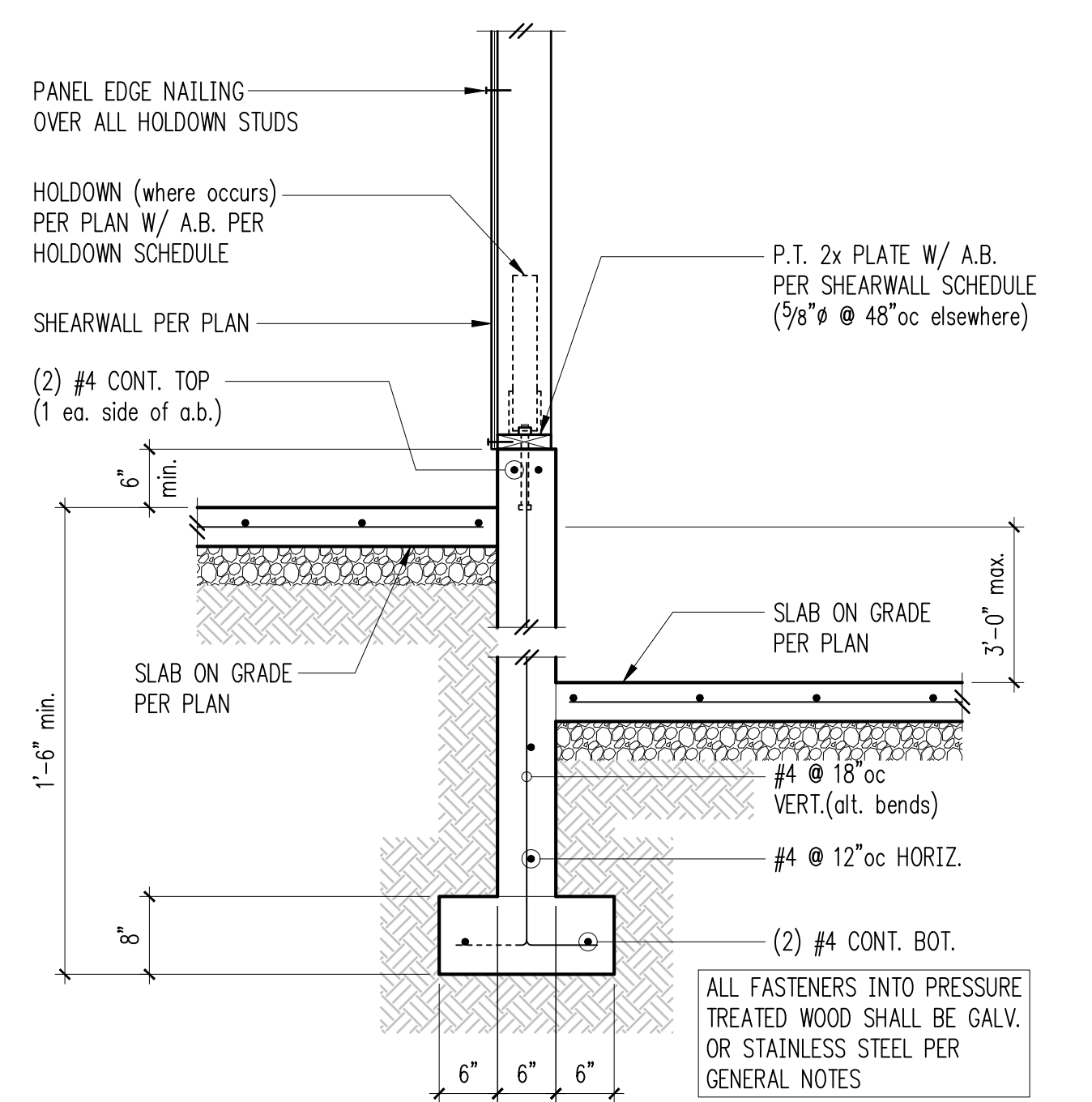

Exterior Wall w/ Slab on Grade & High Grade

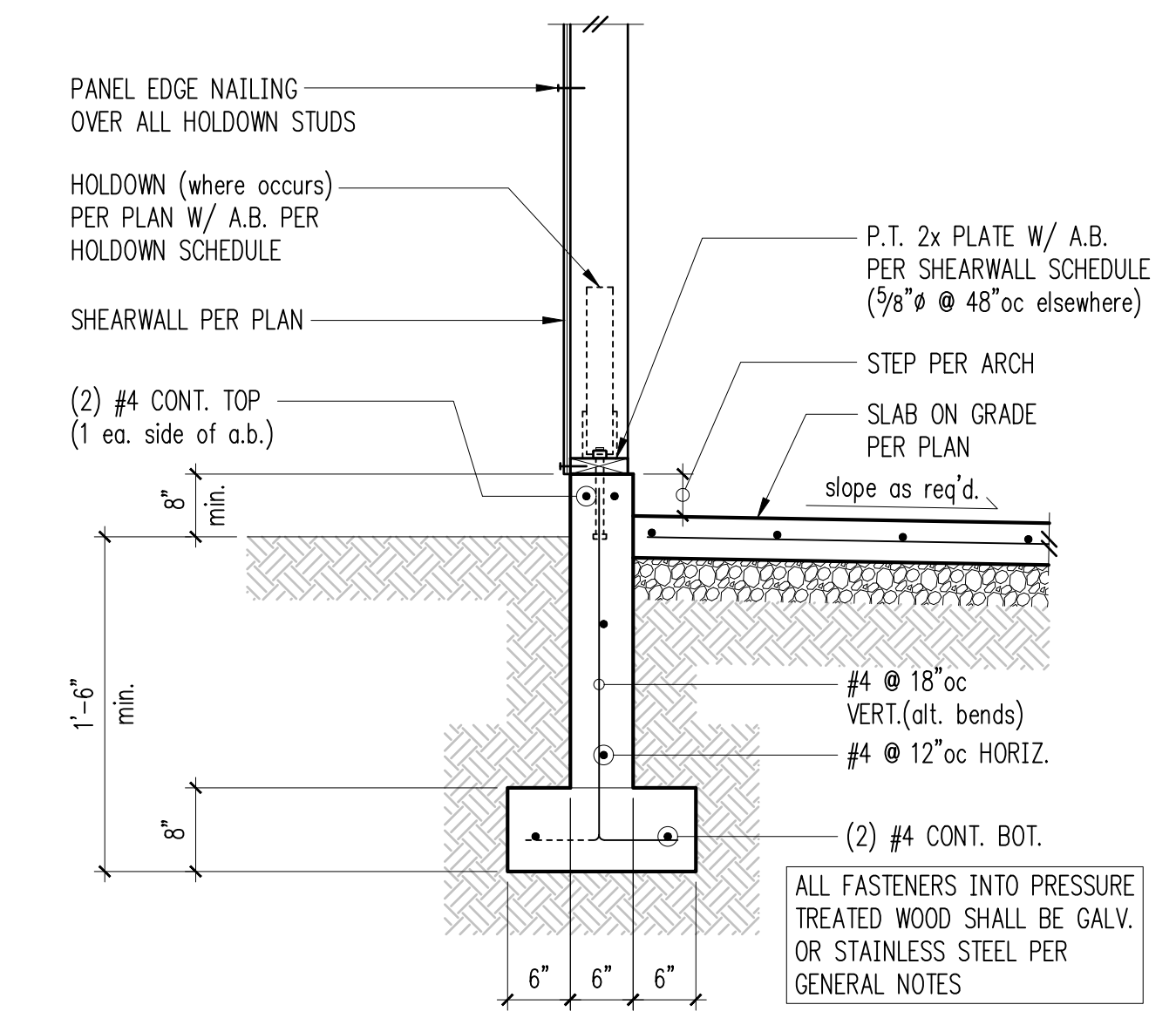

6 inch Garage Wall w/ Slab on Grade

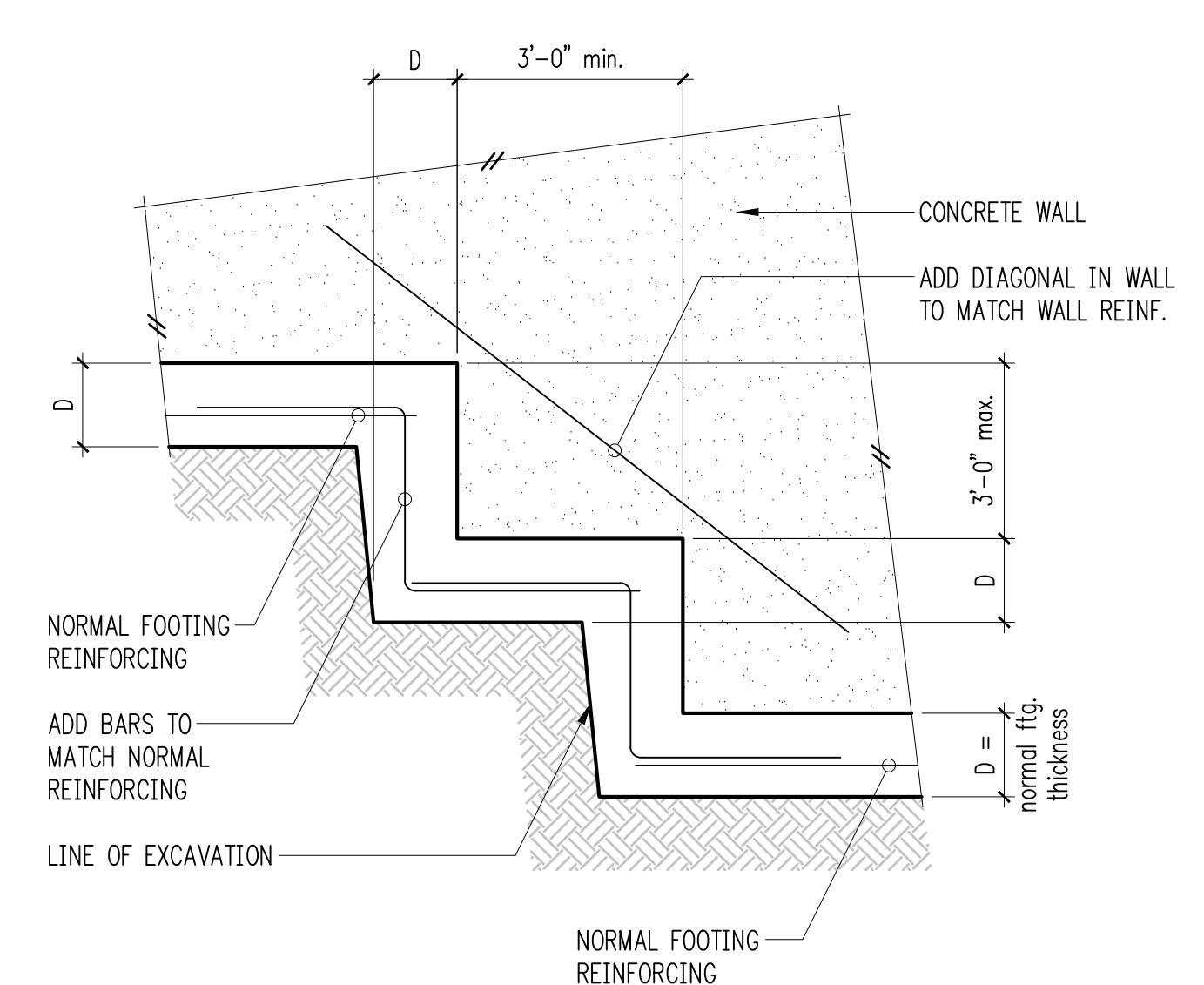

Typical Stepped Footing

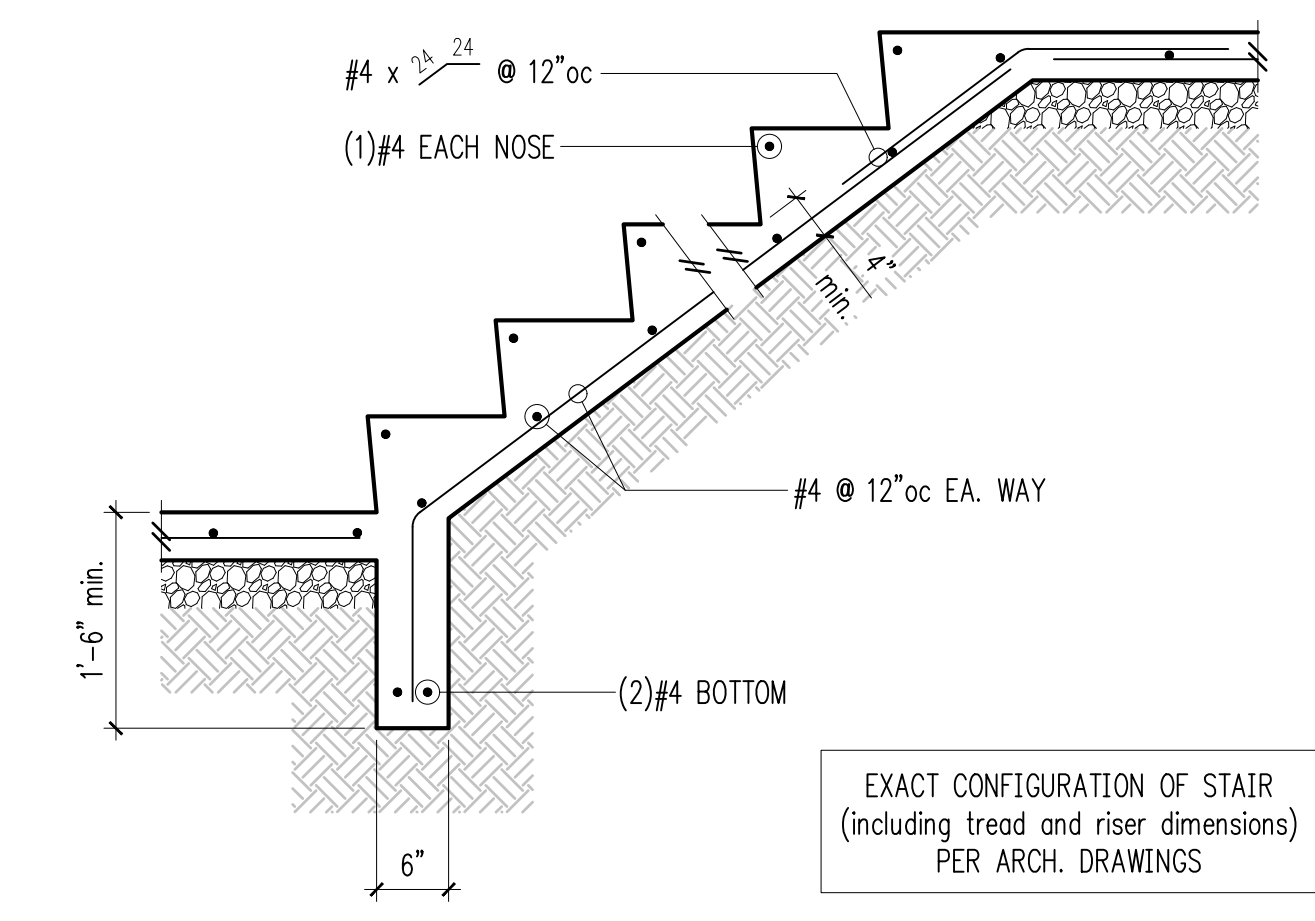

Typical Stair On Grade

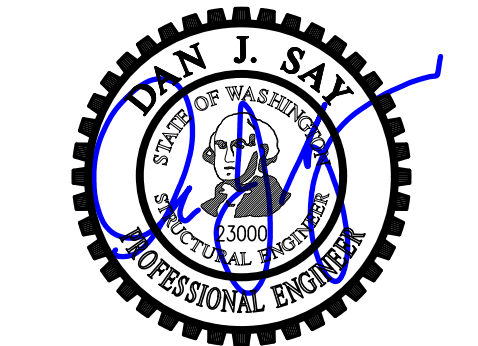

DESIGN: KMR
 DRAWN: NHD
 CHECKED: DJS
 APPROVED: DJS

REVISIONS:
 1 Owner/Geotech Rev. August 3, 2019
 2 Kzt Rev. October 1, 2019
 3 Handrail/Revisions Feb. 5, 2020

JURISDICTIONAL APPROVAL STAMP:

PROJECT TITLE:
Brenes Remodel
 2675 74th Ave SE
 Mercer Island, WA 98040

ARCHITECT:
 Living Shelter Architects, PLLC
 972-A Front Street N
 Issaquah, WA 98027
 PH 425.427.8643

ISSUE:
PERMIT

SHEET TITLE:

Foundation Details

SCALE:
 3/4" = 1'-0" U.N.O.

DATE:
 May 8, 2019

PROJECT NO:
 10592-2018-01

SHEET NO:

S3.2

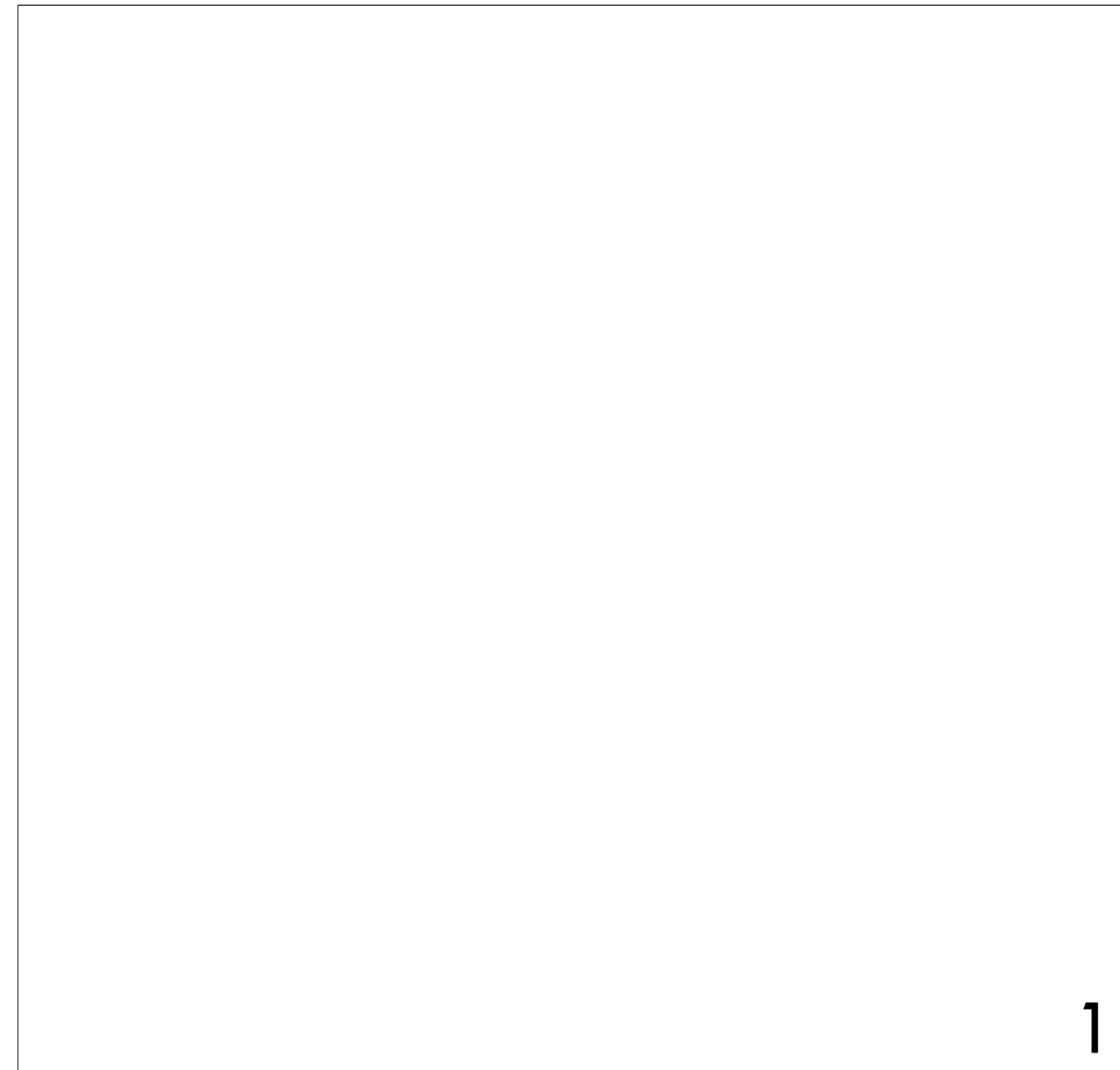

1

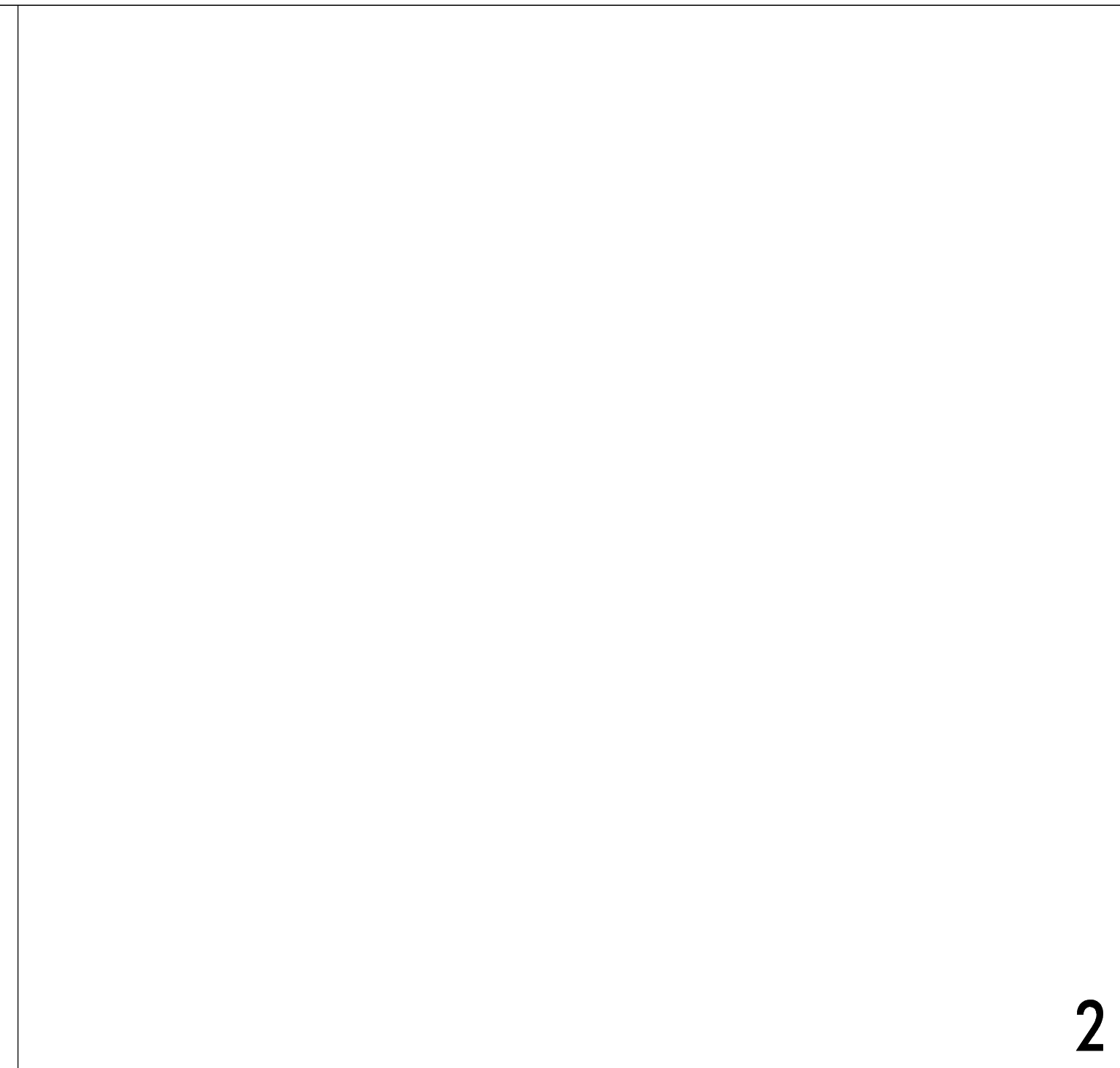

2

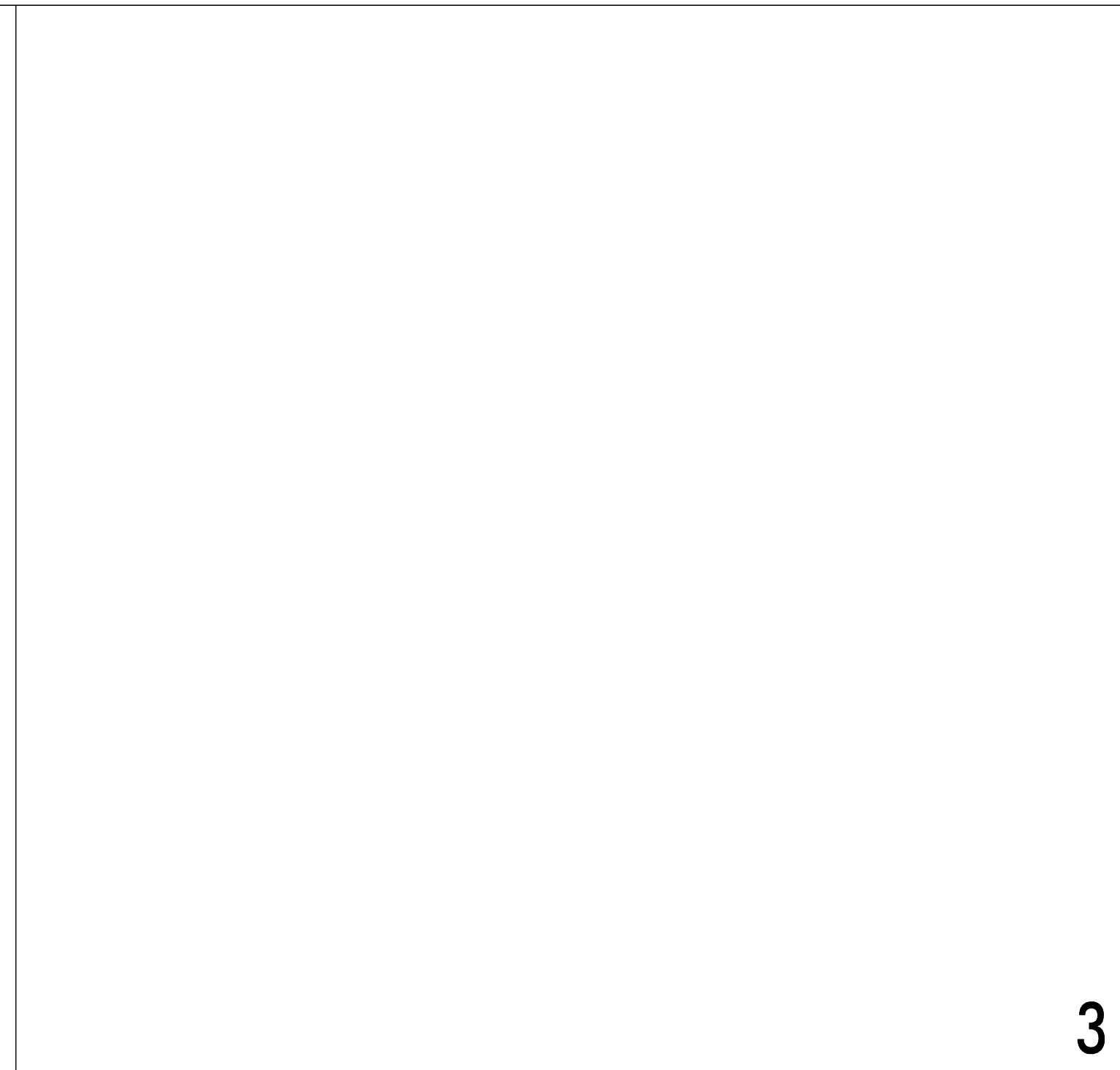

3

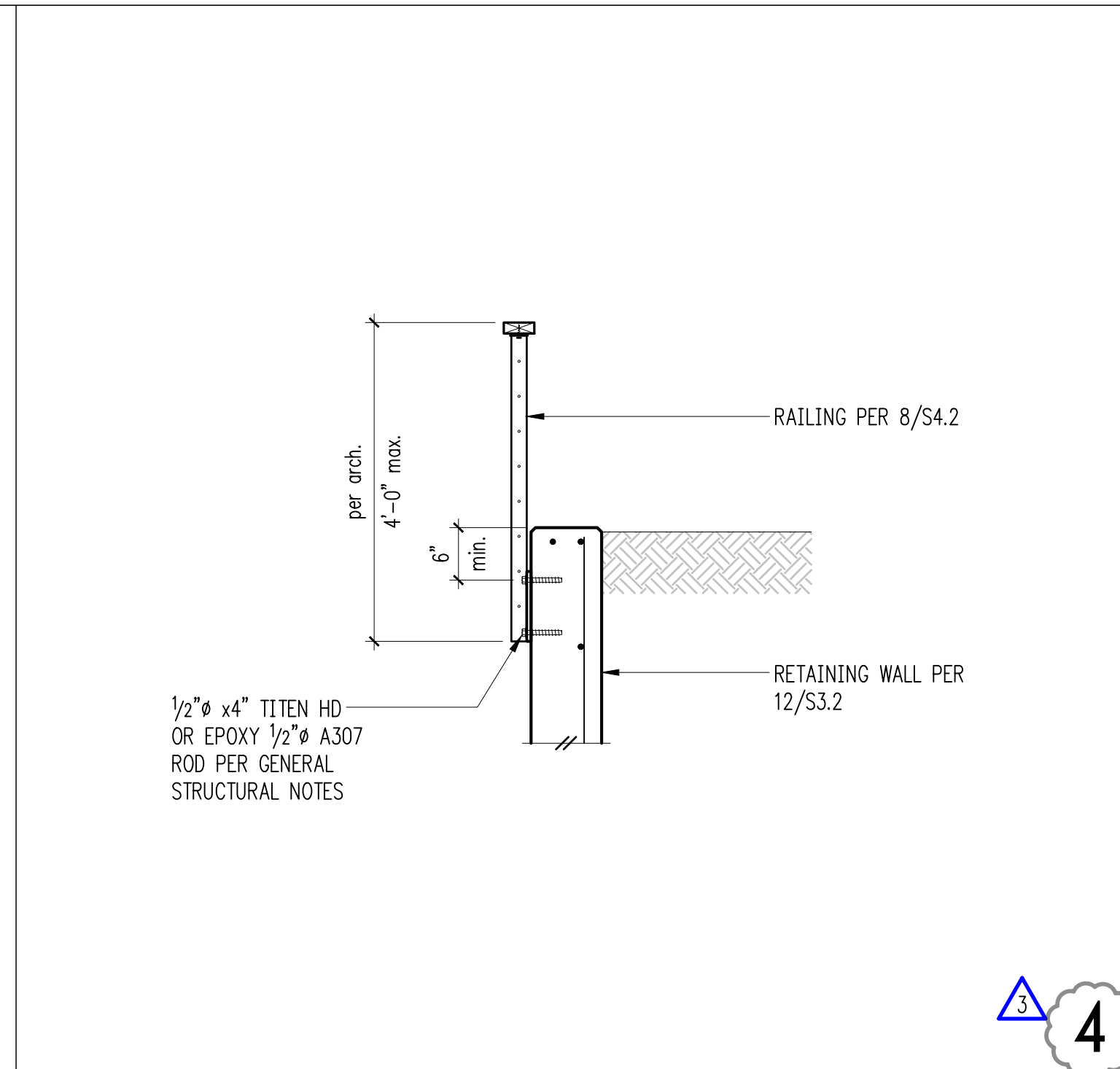

4



5

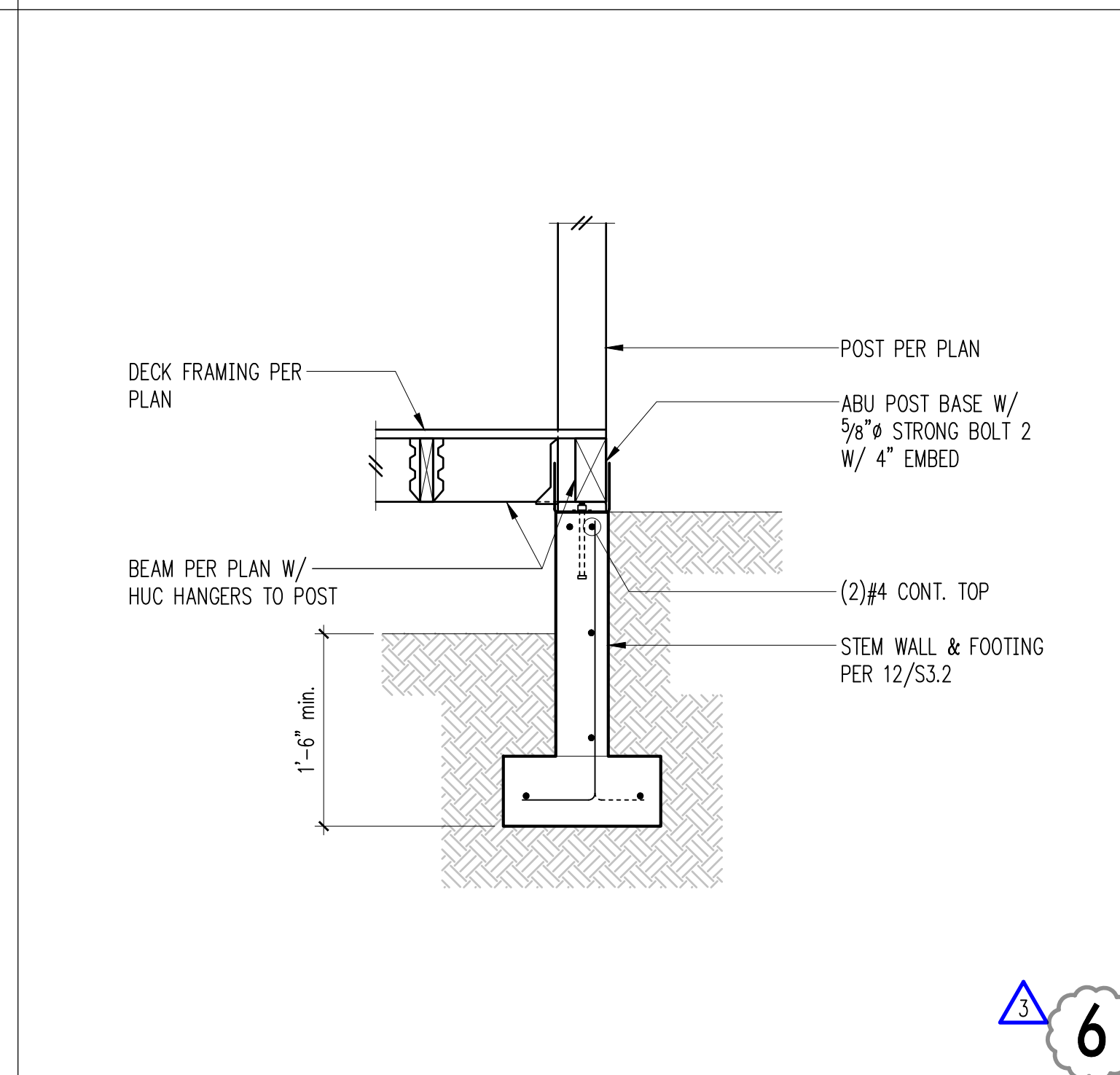

6

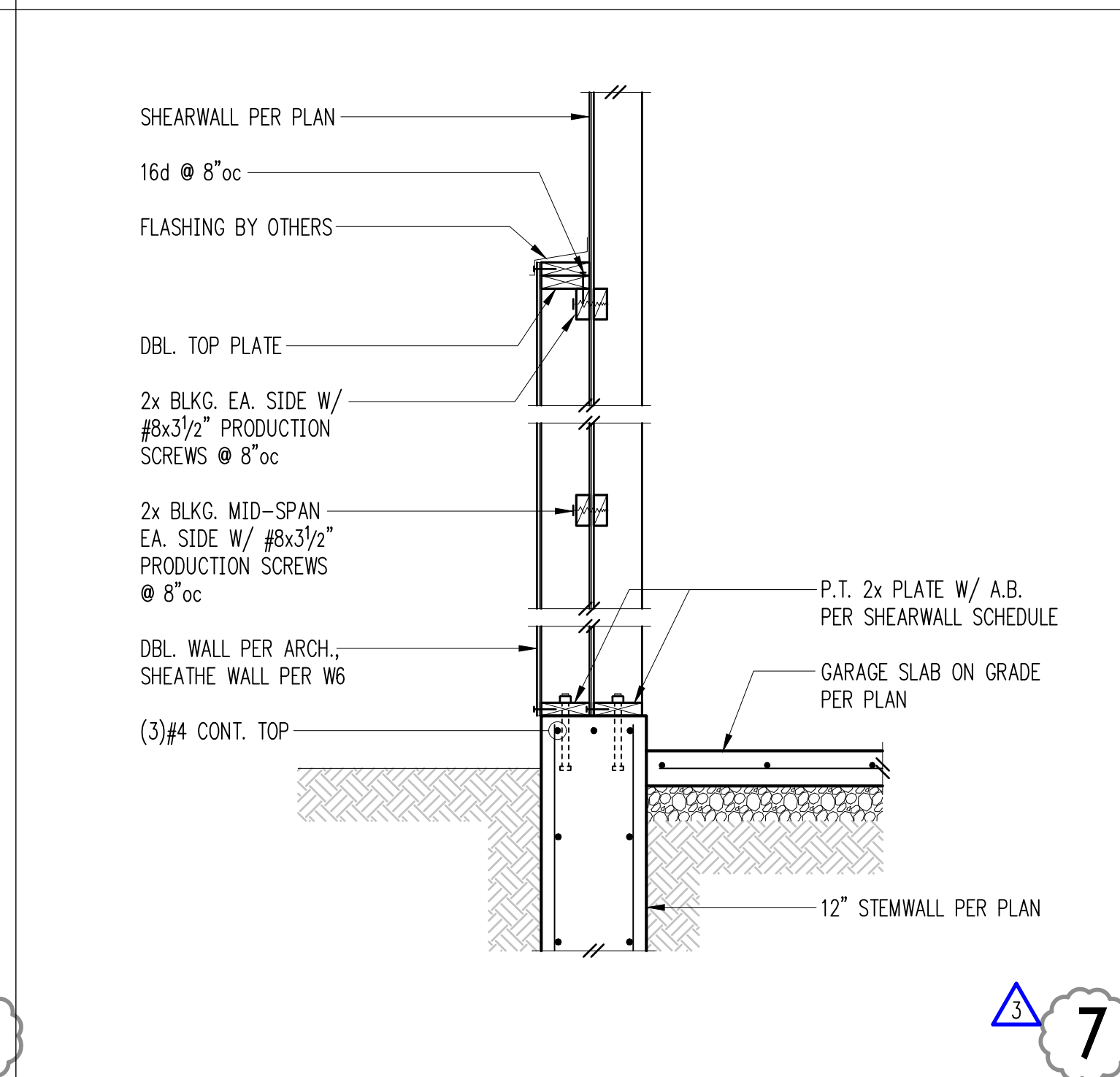

7

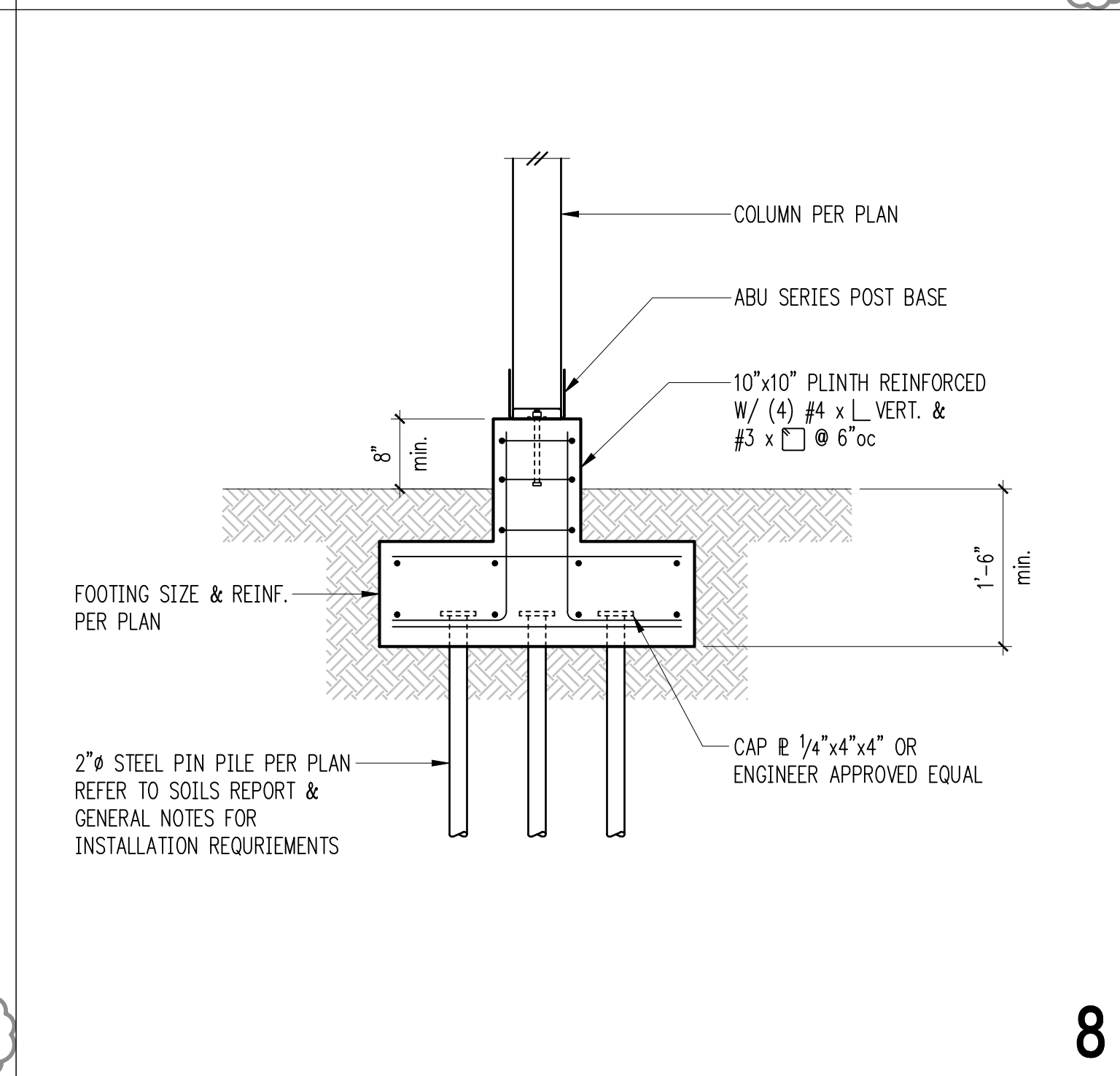

8

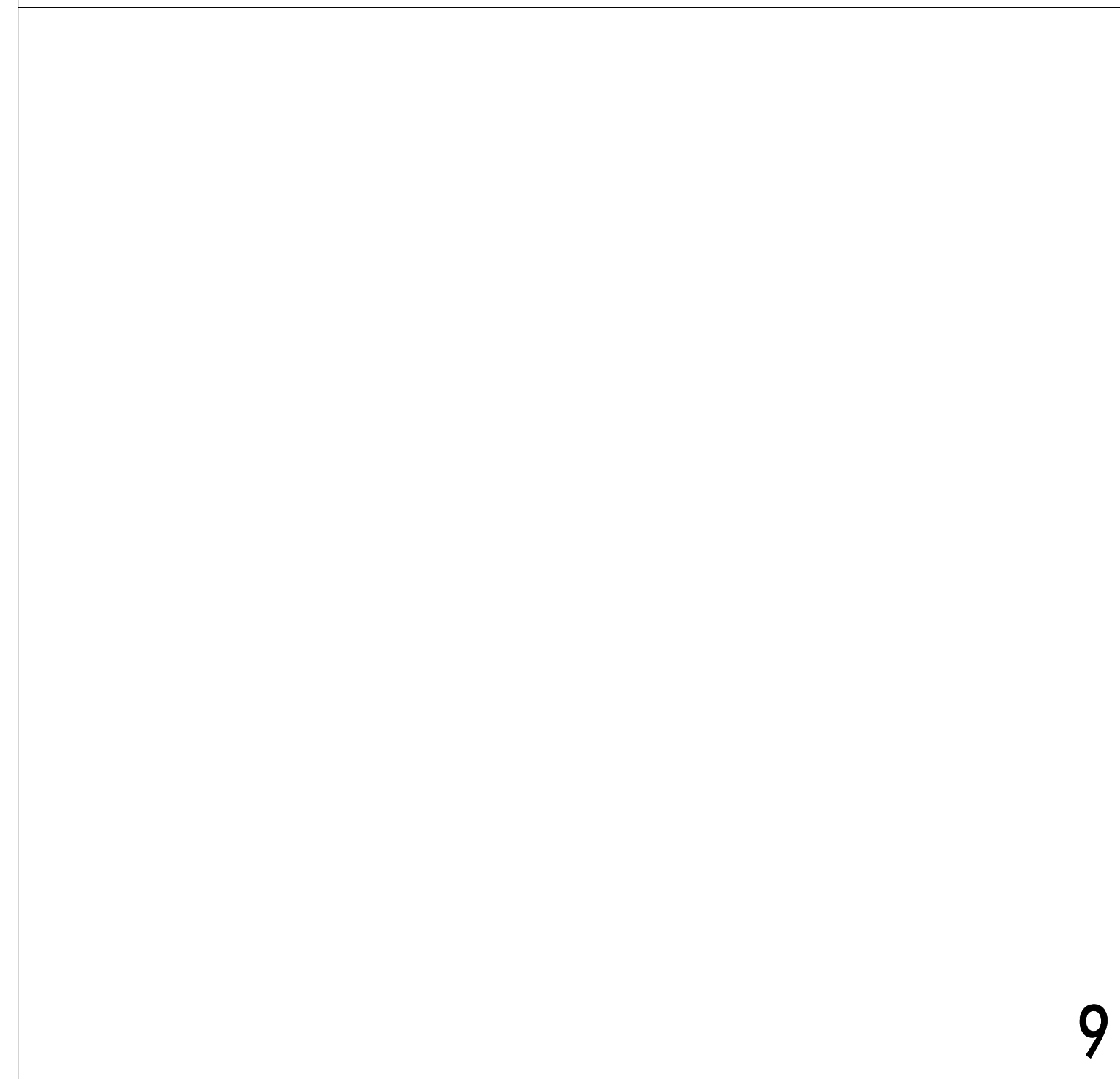

9

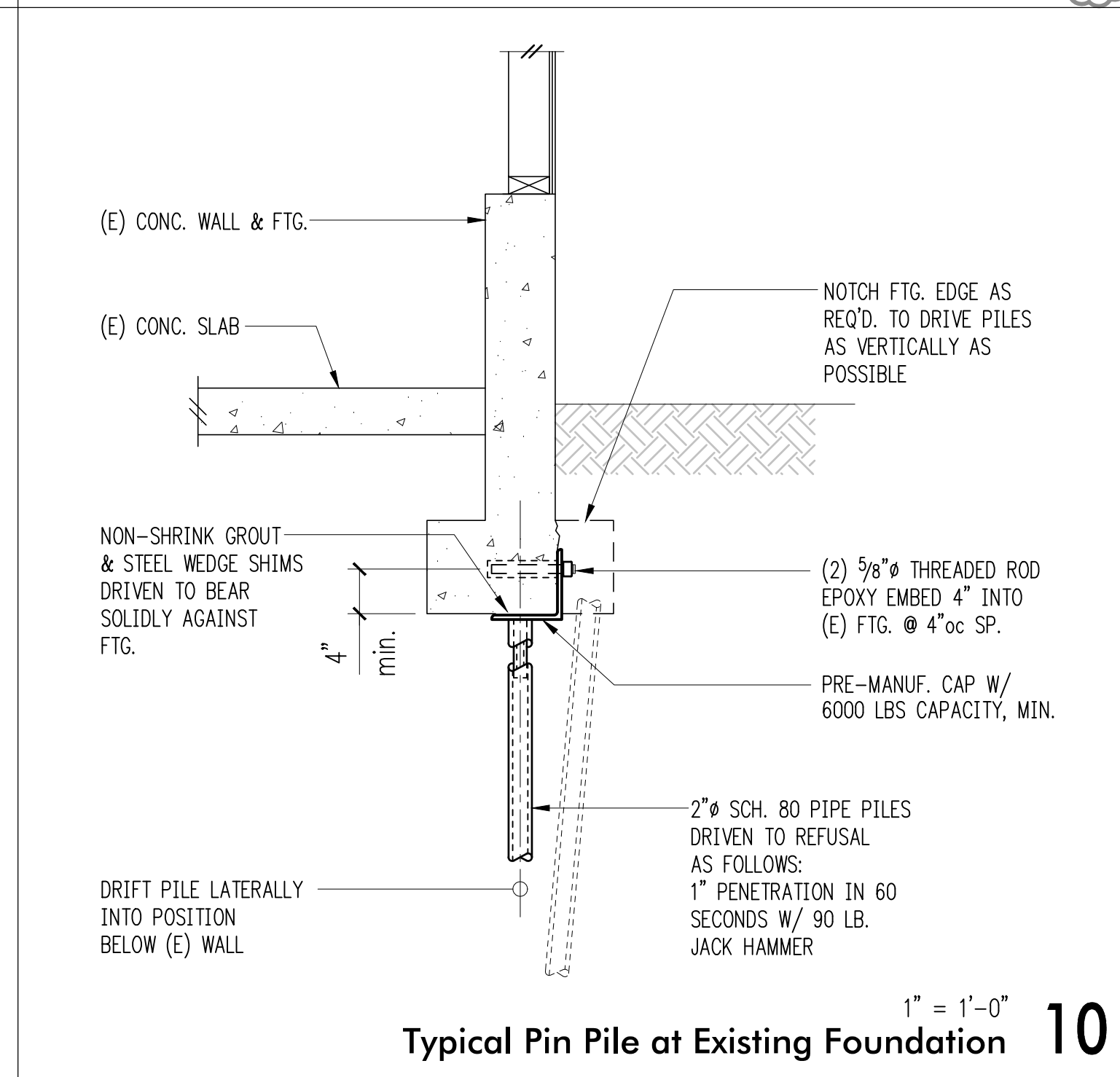

10

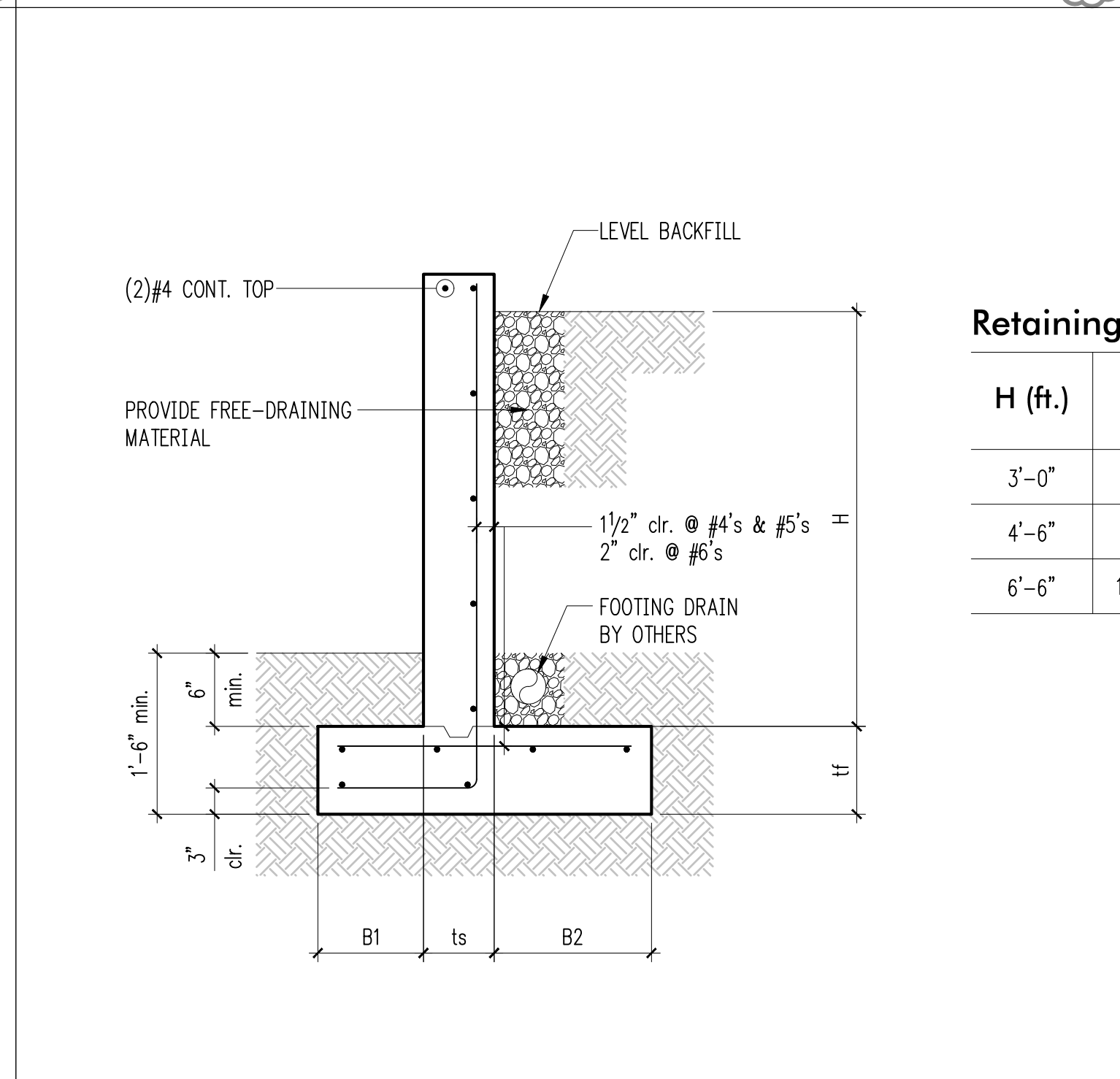

11

Retaining Wall Schedule

H (ft.)	B1	ts	B2	tf	Stem Reinforcing		Footing Reinforcing	
					Vert.	Horiz.	Top	Longit.
3'-0"	6"	6"	6"	8"	#4 @ 18"oc	#4 @ 12"oc	-	(2)#4
4'-6"	6"	6"	1'-6"	8"	#4 @ 18"oc	#4 @ 12"oc	#4 @ 18"oc	(2)#4
6'-6"	1'-0"	6"	2'-0"	12"	#4 @ 12"oc	#4 @ 12"oc	#4 @ 12"oc	(4)#4

Typical Site Wall 12

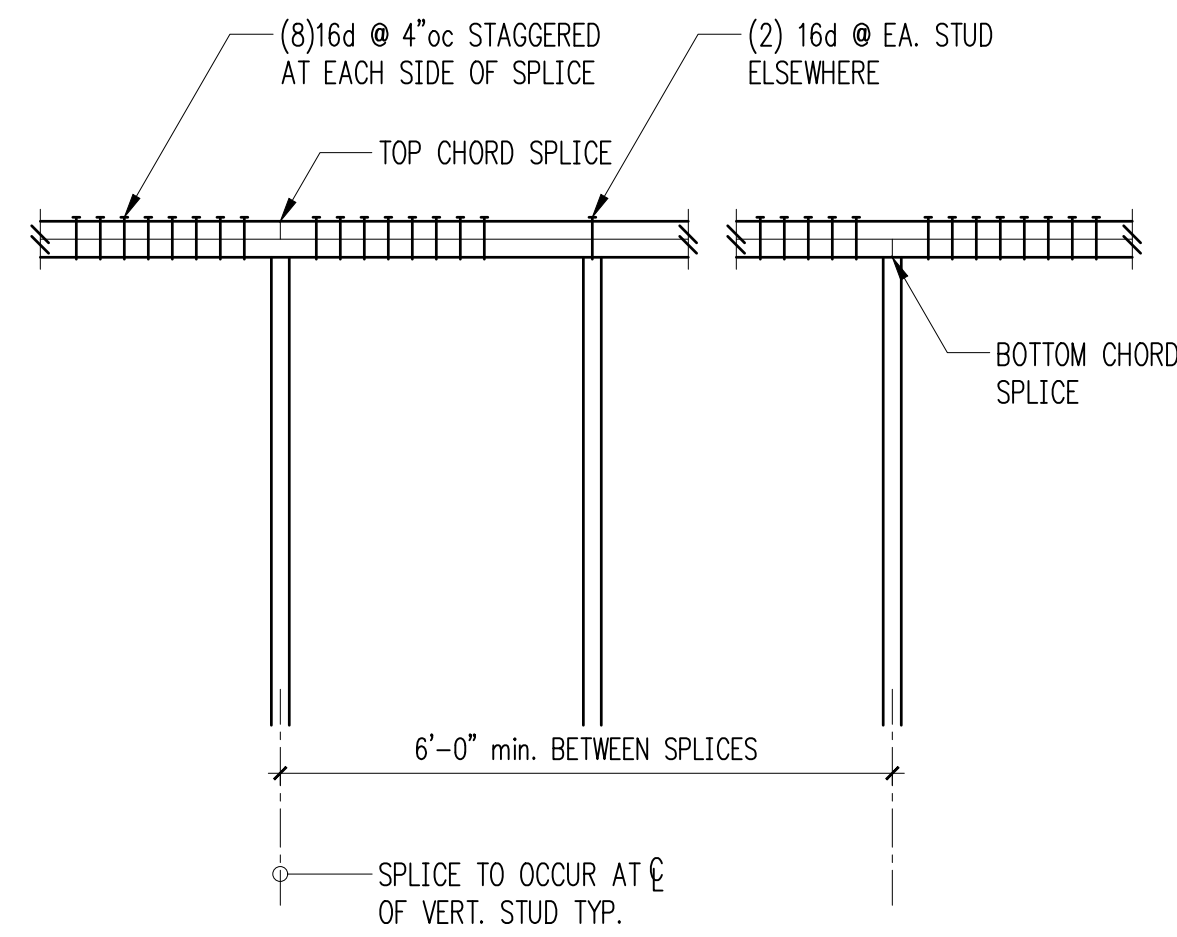

Typical Top Plate Splice 1

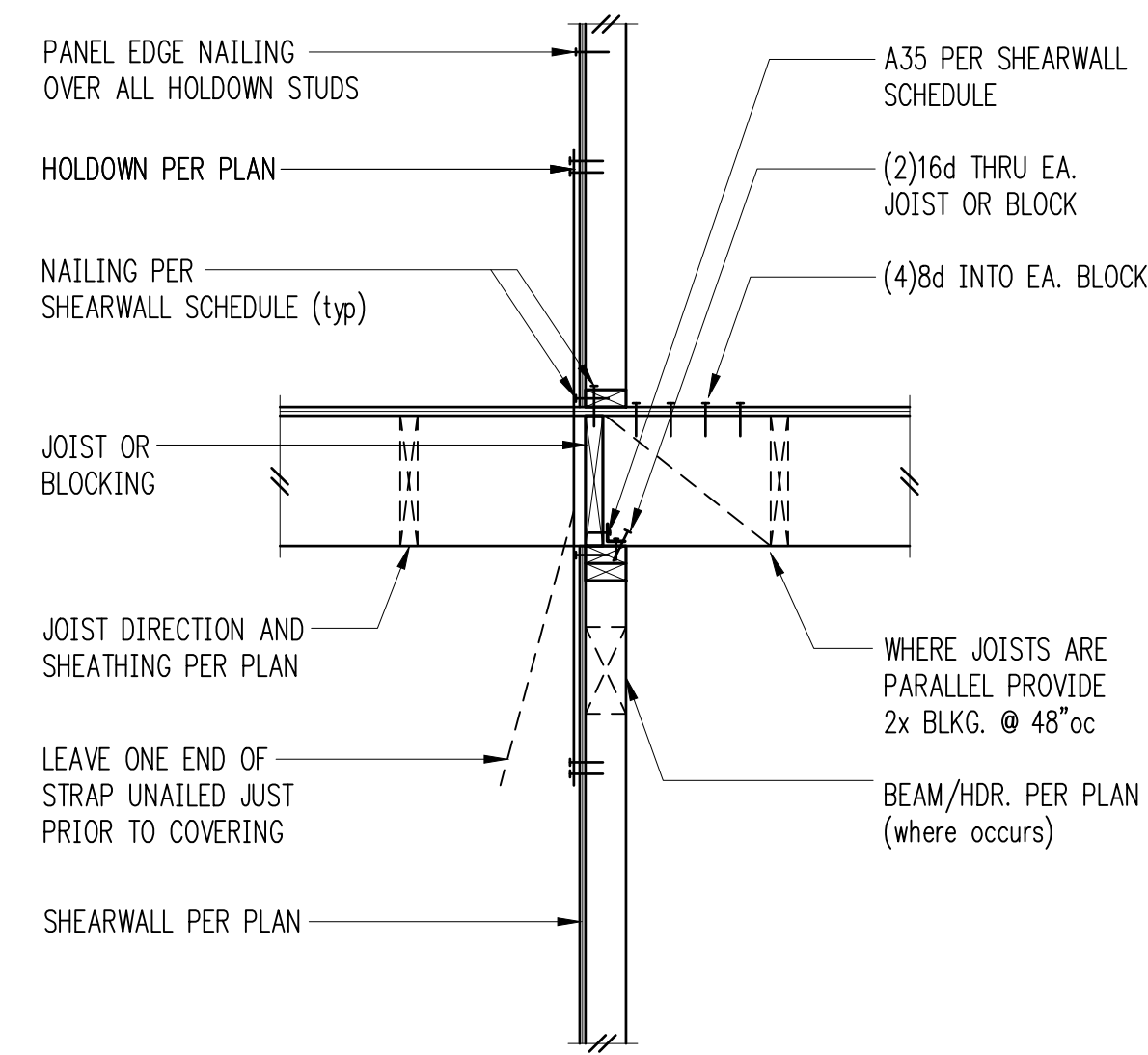

Interior Shearwall 2

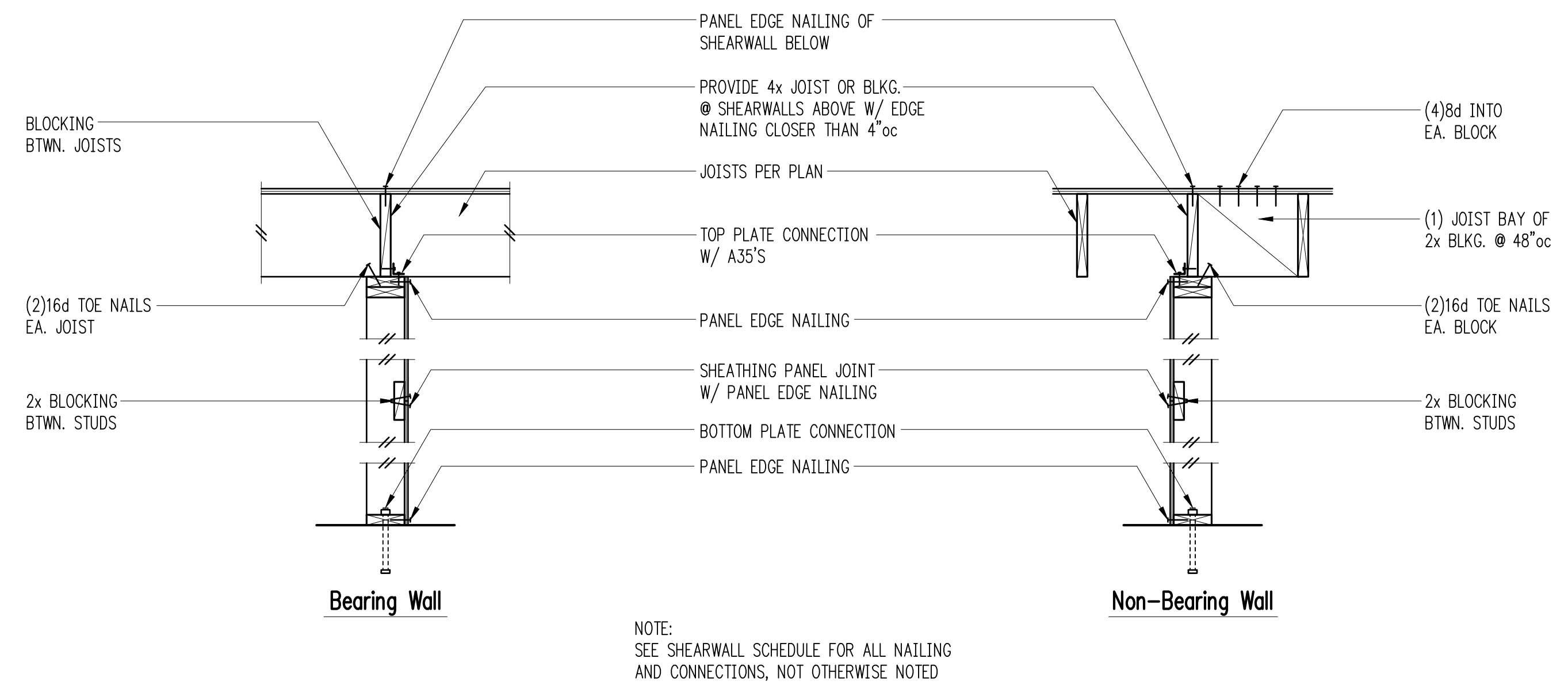

Typical Shearwall Construction 4

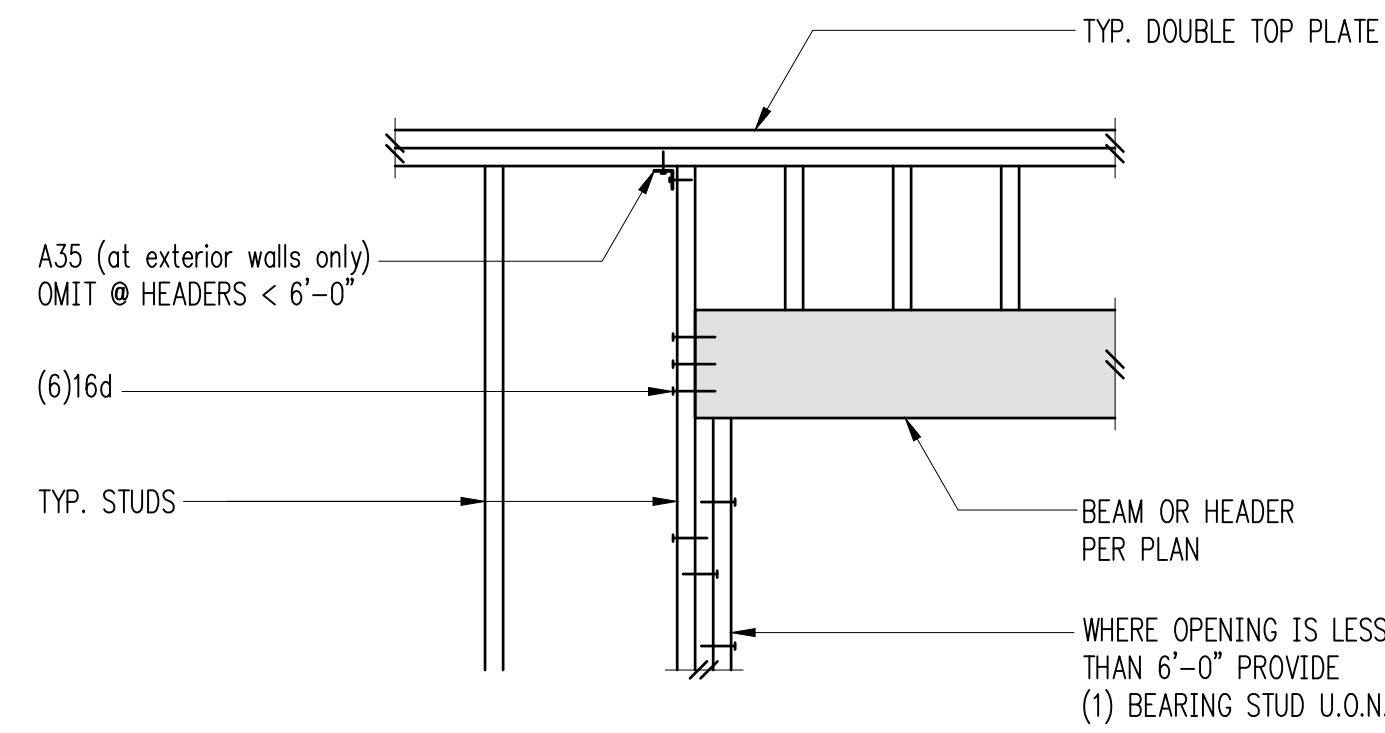

Typical Header Support 5

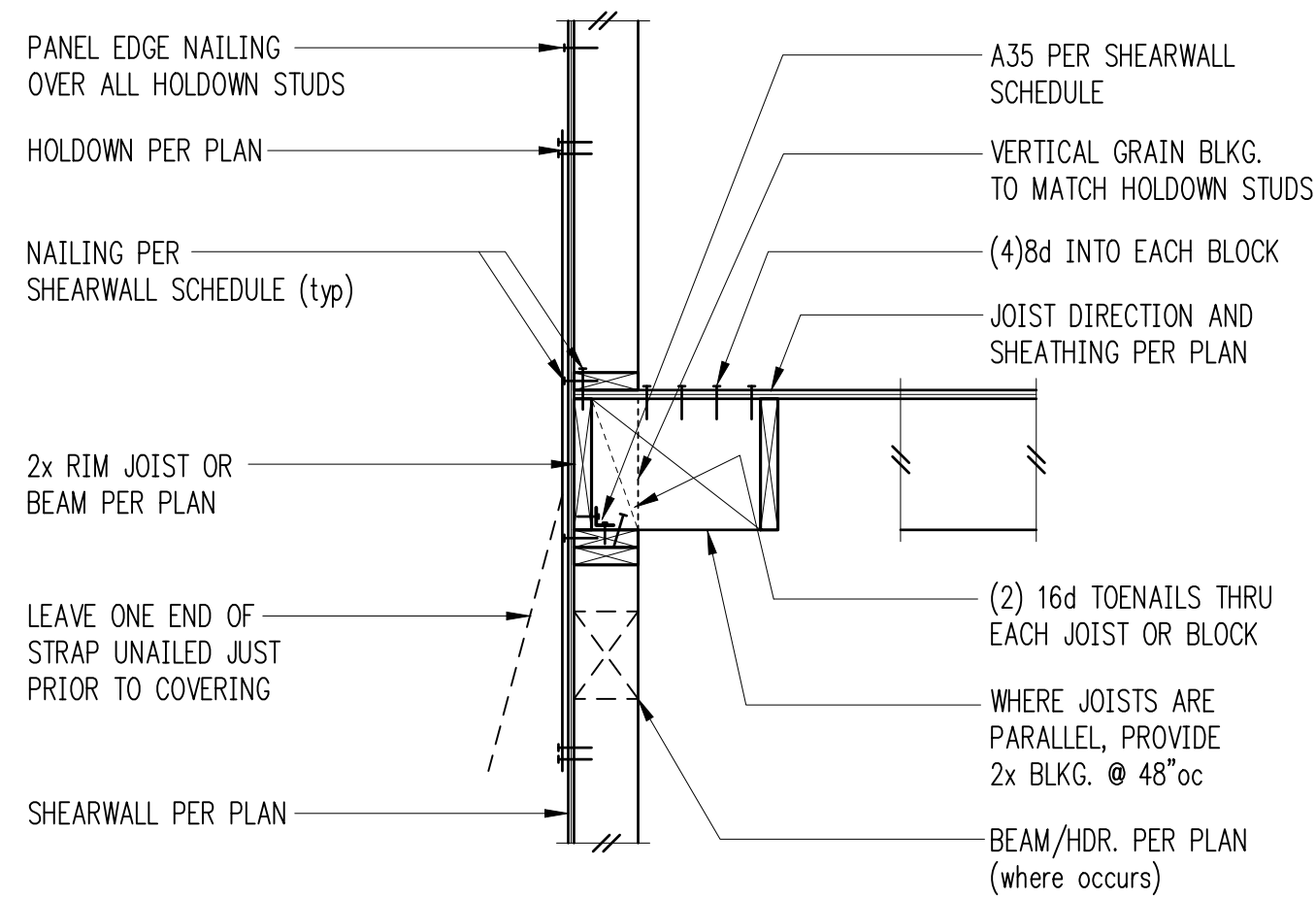

Exterior Floor Framing 6

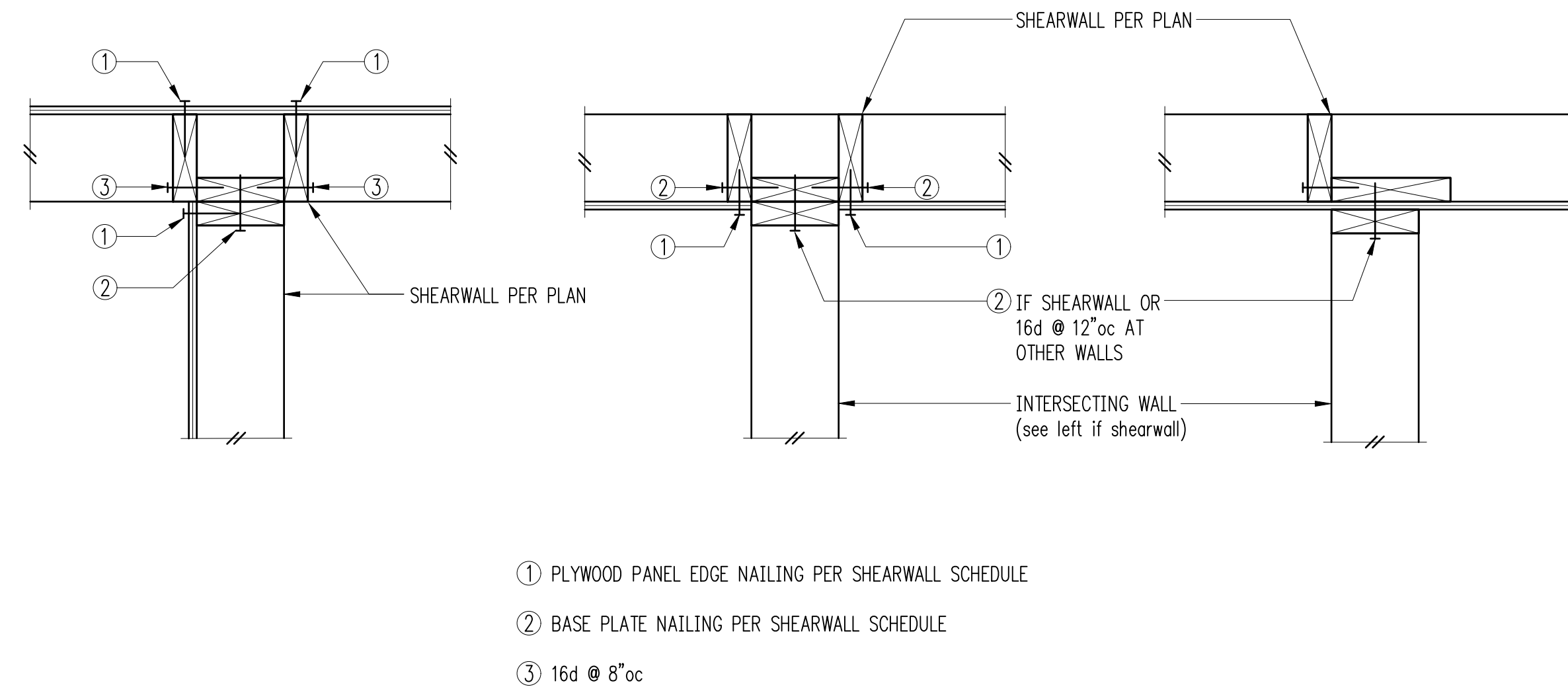

Typical Shearwall Intersections 8

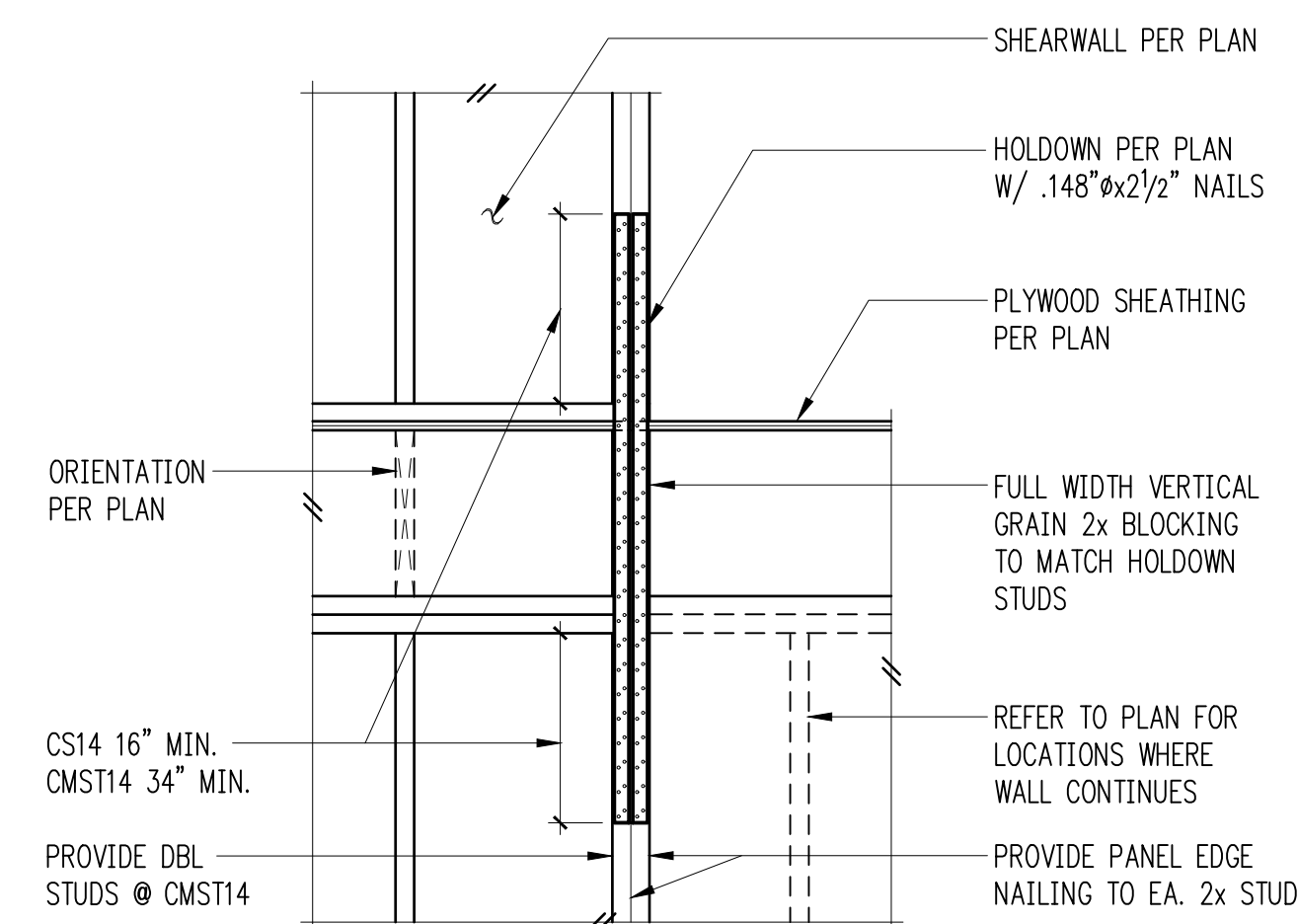

Typical Strap Holddown 9

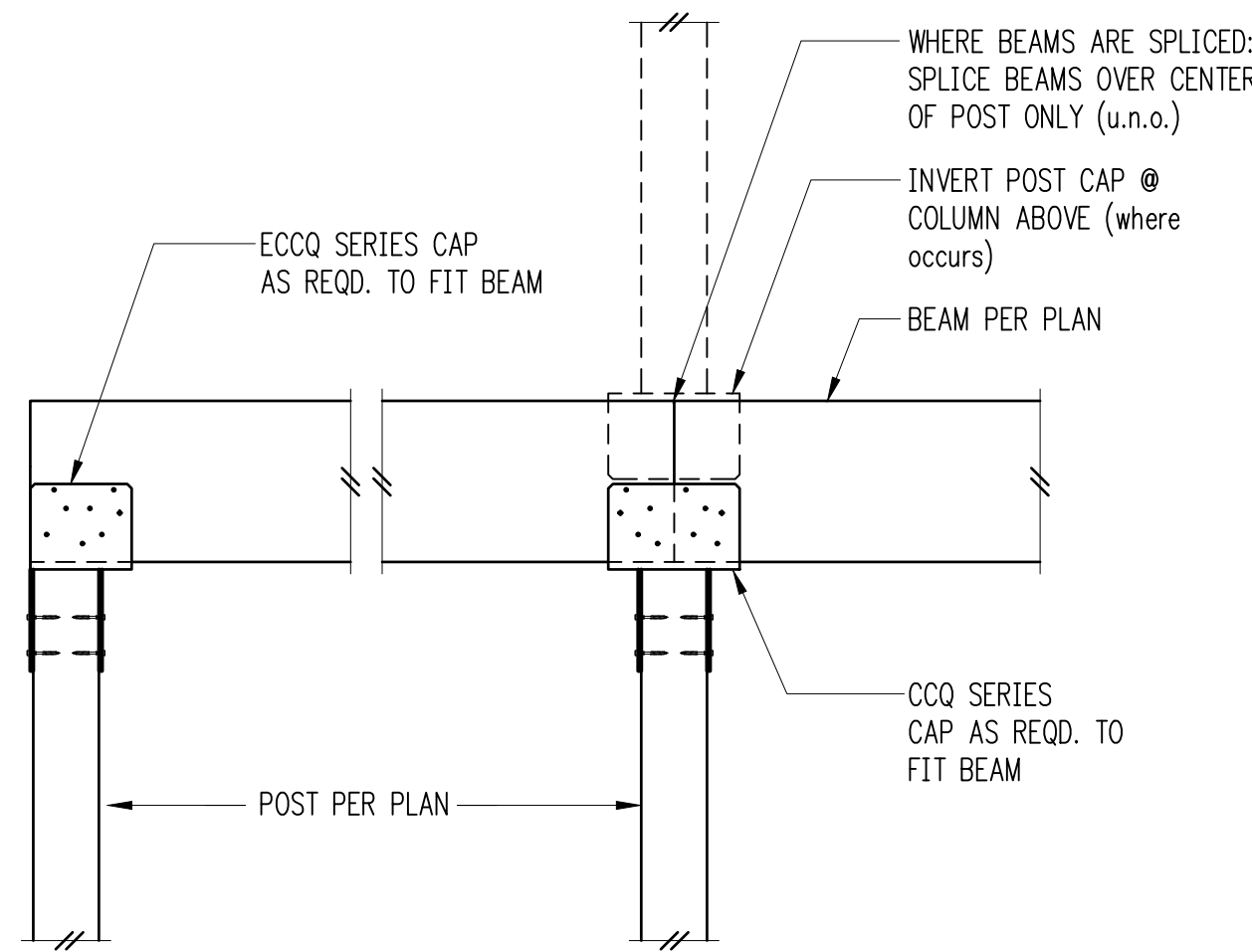

CC/CCQ Series Connection 10

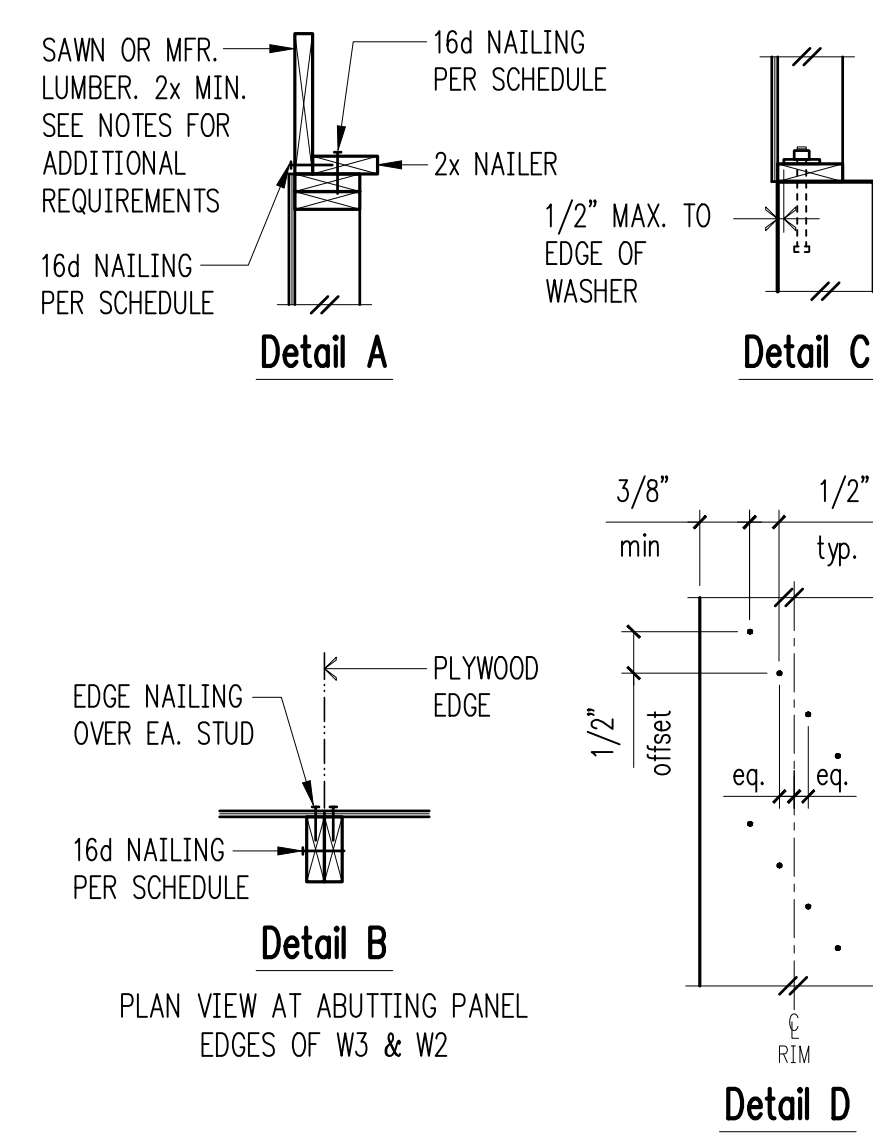

Shearwall Schedule ①②③④⑤⑥⑦

Mark	Sheathing	Panel Edge Nailing	Top Plate Connection		Base Plate Connection	
			if TJI	if Wood ③	at Wood ⑩	at Concrete
W6	15/32" CDX PLYWOOD	8d @ 6"oc	16d @ 6"oc	A35 @ 24"oc	16d @ 6"oc	5/8" A.B. @ 48"oc
W4	15/32" CDX PLYWOOD	8d @ 4"oc	16d @ 4"oc	A35 @ 16"oc	(2)rows 16d @ 6"oc	5/8" A.B. @ 32"oc
W3 ④	15/32" CDX PLYWOOD	8d @ 3"oc	(2)rows 16d @ 4"oc	A35 @ 12"oc	(2)rows 16d @ 6"oc	5/8" A.B. @ 24"oc
W2 ④	15/32" CDX PLYWOOD	8d @ 2"oc	(2)rows 16d @ 4"oc	A35 @ 9"oc	(2)rows 16d @ 4"oc ⑪	5/8" A.B. @ 16"oc

- ① BLOCK PANEL EDGES WITH 2x MIN. LAID FLAT AND NAIL PANELS TO INTERMEDIATE SUPPORTS WITH 8d @ 12"o.c.
- ② 8d NAILS SHALL BE 0.131" x 2 1/2" (common) - 16d NAILS SHALL BE 0.135" x 3 1/2" (box)
- ③ EMBED ANCHOR BOLTS AT LEAST 7". EXPANSION BOLTS MAY BE SUBSTITUTED FOR ANCHOR BOLTS WITH 4" EMBEDMENT. TITEN HD SCREW ANCHORS MAY BE SUBSTITUTED FOR ANCHOR BOLTS W/ 4" EMBEDMENT. ALL BOLTS SHALL HAVE 3" x 3" x 1/4" MIN. PLATE WASHERS. PLATE WASHERS SHALL EXTEND TO WITHIN 1/2" OF THE EDGE OF THE BOTTOM PLATE ON THE SIDE WITH SHEATHING. SEE DETAIL C.
- ④ 3x STUDS OR DOUBLE STUDS NAILED TOGETHER W/ BASE PLATE NAILING ARE REQUIRED AT ABUTTING PANEL EDGES OF W3 AND W2. SEE DETAIL B. WHERE 3x STUDS ARE USED FOR W2, STAGGER NAILS AT ADJOINING PANEL EDGES.
- ⑤ TWO STUDS MINIMUM ARE REQUIRED AT EACH END OF ALL SHEARWALLS AND ALL END STUDS SHALL RECEIVE PANEL EDGE NAILING. SEE PLANS AND HOLDOWN SCHEDULE FOR ALTERNATE REQUIREMENTS.
- ⑥ ALL EXTERIOR WALLS SHALL BE W6, UNLESS NOTED OTHERWISE.
- ⑦ 7/16" O.S.B. MAY BE SUBSTITUTED FOR 15/32" CDX.
- ⑧ LTP4's (HORIZONTAL ORIENTATION) W/ 8d COMMON MAY BE SUBSTITUTED FOR A35's AT CONTRACTORS OPTION.
- ⑨ A 2x NAILER ATTACHED W/ BASE PLATE NAILING PER DETAIL A MAY BE SUBSTITUTED FOR A35's AT CONTRACTORS OPTION.
- ⑩ AT MULTI-ROW NAILING, MINIMUM OFFSET BETWEEN ROWS AND ROW SPACING 1/2", SEE DETAIL D.
- ⑪ PROVIDE (3) ROWS 16d @ 6"oc AT LVL RIMS.

Shearwall Schedule - (Sheathed One Side) 12

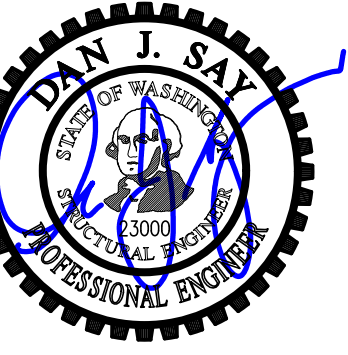

DESIGN: KMR
 DRAWN: NHD
 CHECKED: DJS
 APPROVED: DJS

- REVISIONS:
- 1 Owner/Geotech Rev. August 3, 2019
 - 2 Kzt Rev. October 1, 2019
 - 3 Handrail/Revisions Feb. 5, 2020

JURISDICTIONAL APPROVAL STAMP:

PROJECT TITLE:
Brenes Remodel
 2675 74th Ave SE
 Mercer Island, WA 98040

ARCHITECT:
Living Shelter Architects, PLLC
 972-A Front Street N
 Issaquah, WA 98027
 PH 425.427.8643

ISSUE:
PERMIT
 SHEET TITLE:

Typical Wood Framing Details
 SCALE: 3/4" = 1'-0" U.N.O.
 DATE: May 8, 2019
 PROJECT NO: 10592-2018-01
 SHEET NO:

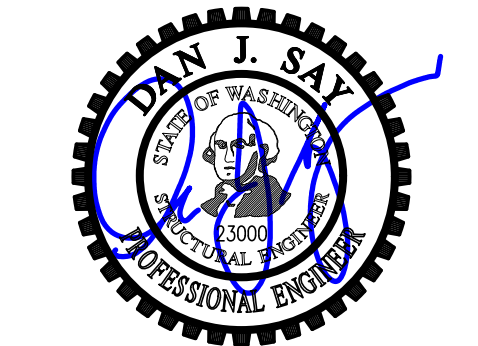

DESIGN: KMR
 DRAWN: NHD
 CHECKED: DJS
 APPROVED: DJS

REVISIONS:

1	Owner/Geotech Rev.	August 3, 2019
2	Kzt Rev.	October 1, 2019
3	Handrail/Revisions	Feb. 5, 2020

JURISDICTIONAL APPROVAL STAMP:

PROJECT TITLE:
Brenes Remodel
 2675 74th Ave SE
 Mercer Island, WA 98040

ARCHITECT:
Living Shelter Architects, PLLC
 972-A Front Street N
 Issaquah, WA 98027
 PH 425.427.8643

ISSUE:
PERMIT

SHEET TITLE:
Wood Framing Details

SCALE: 3/4" = 1'-0" U.N.O.
 DATE: May 8, 2019
 PROJECT NO: 10592-2018-01
 SHEET NO:

S4.2

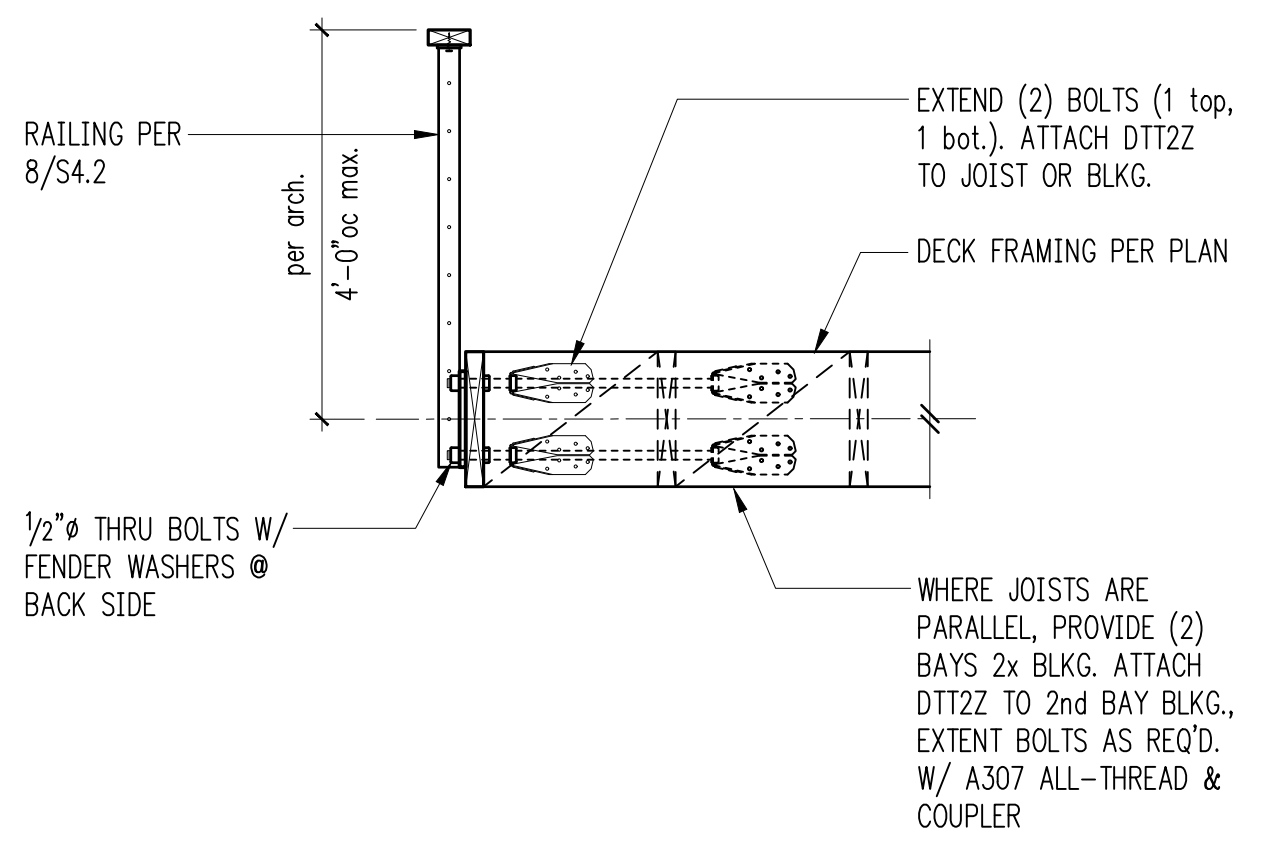

3 1

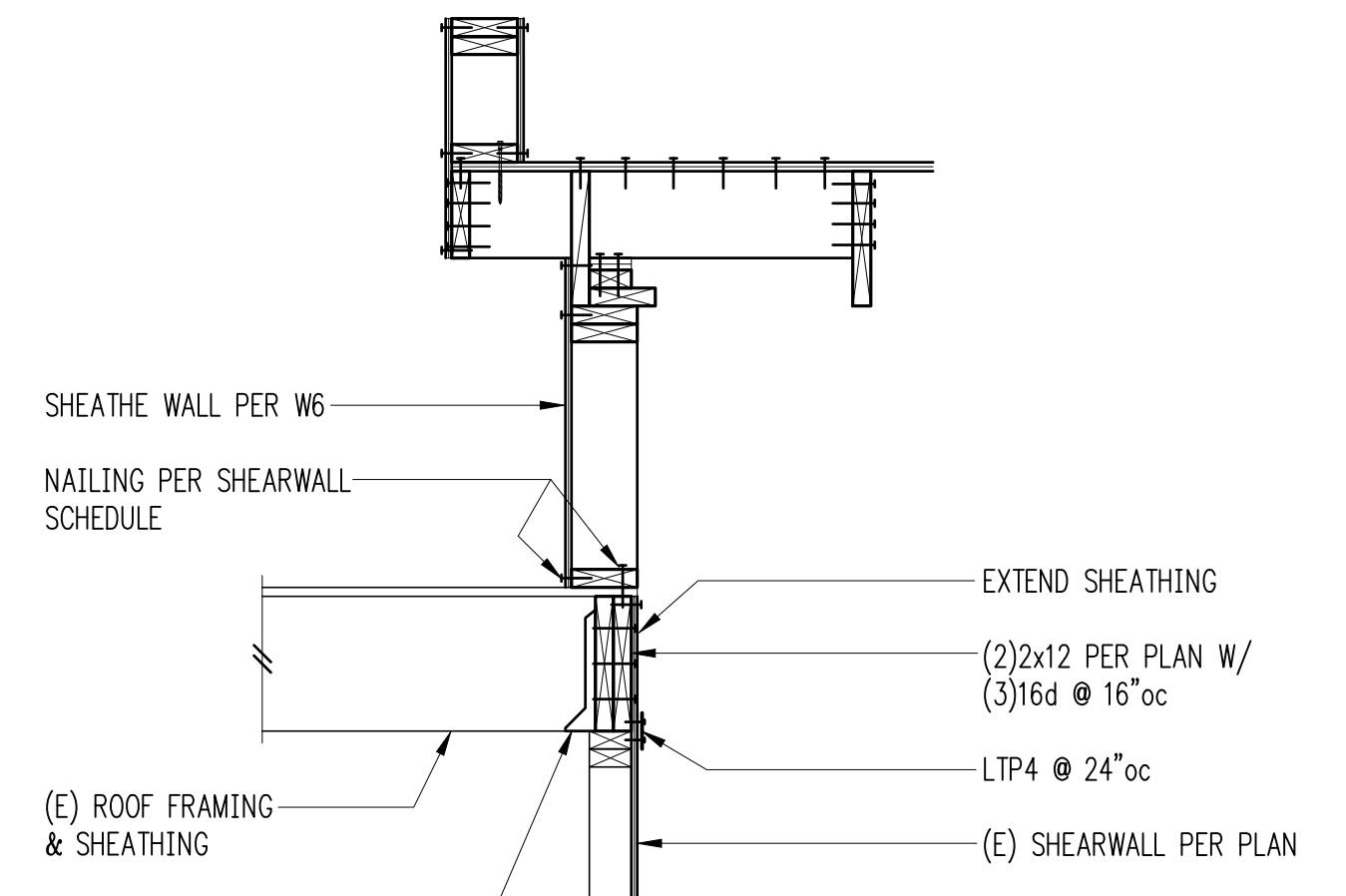

FOR CALLOUTS IN COMMON REFER 5/S4.2

3 2

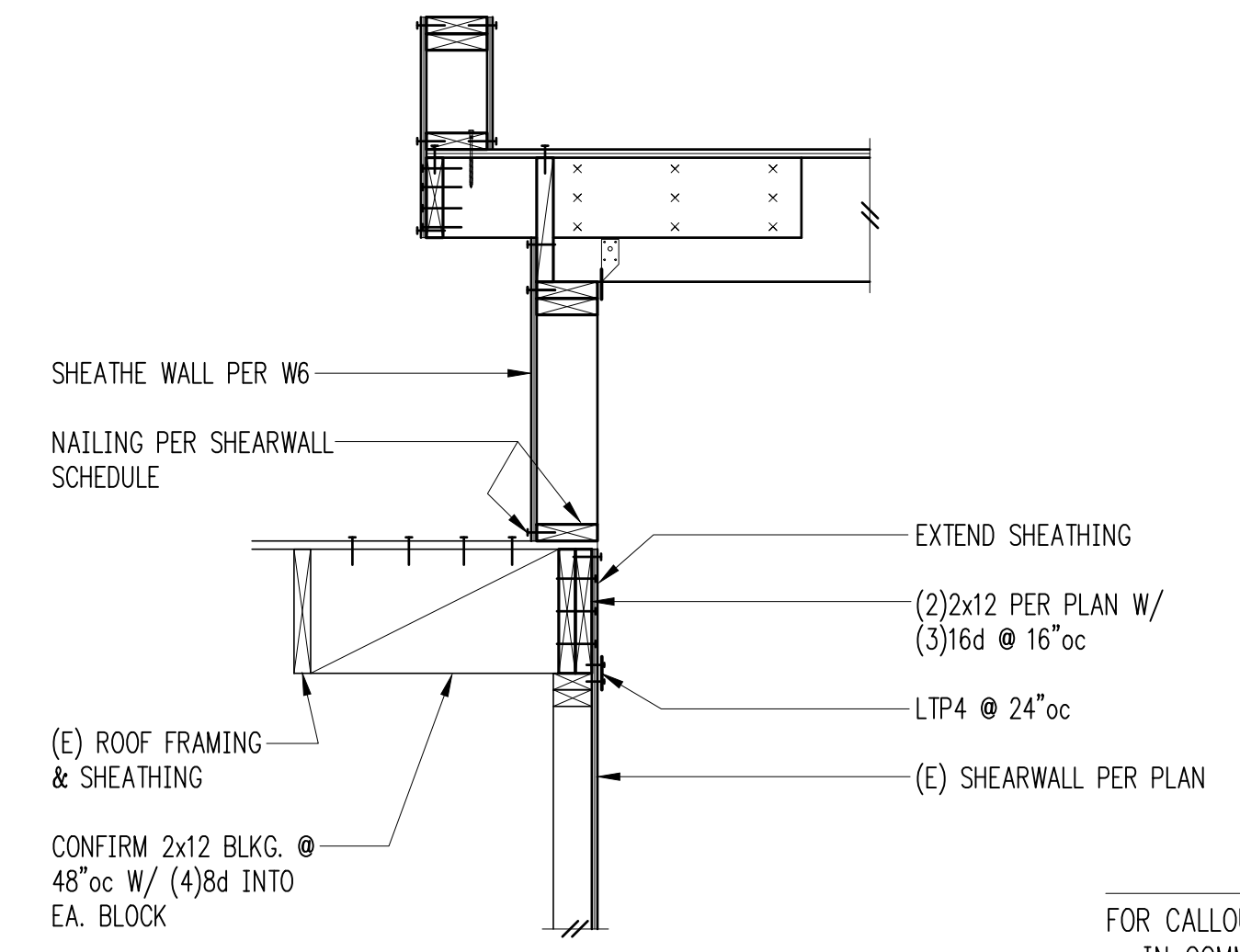

FOR CALLOUTS IN COMMON REFER 6/S4.2

3 3

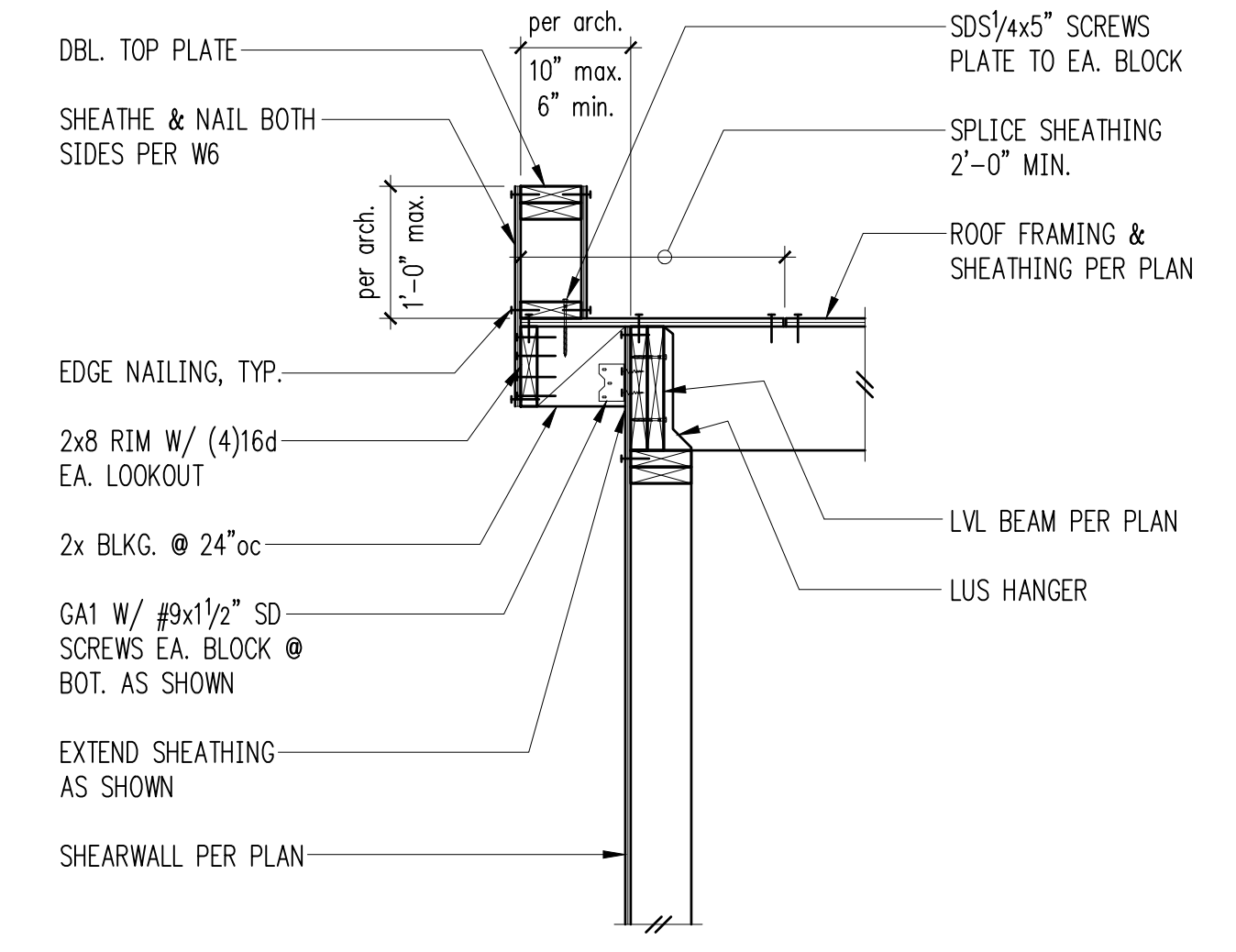

3 4

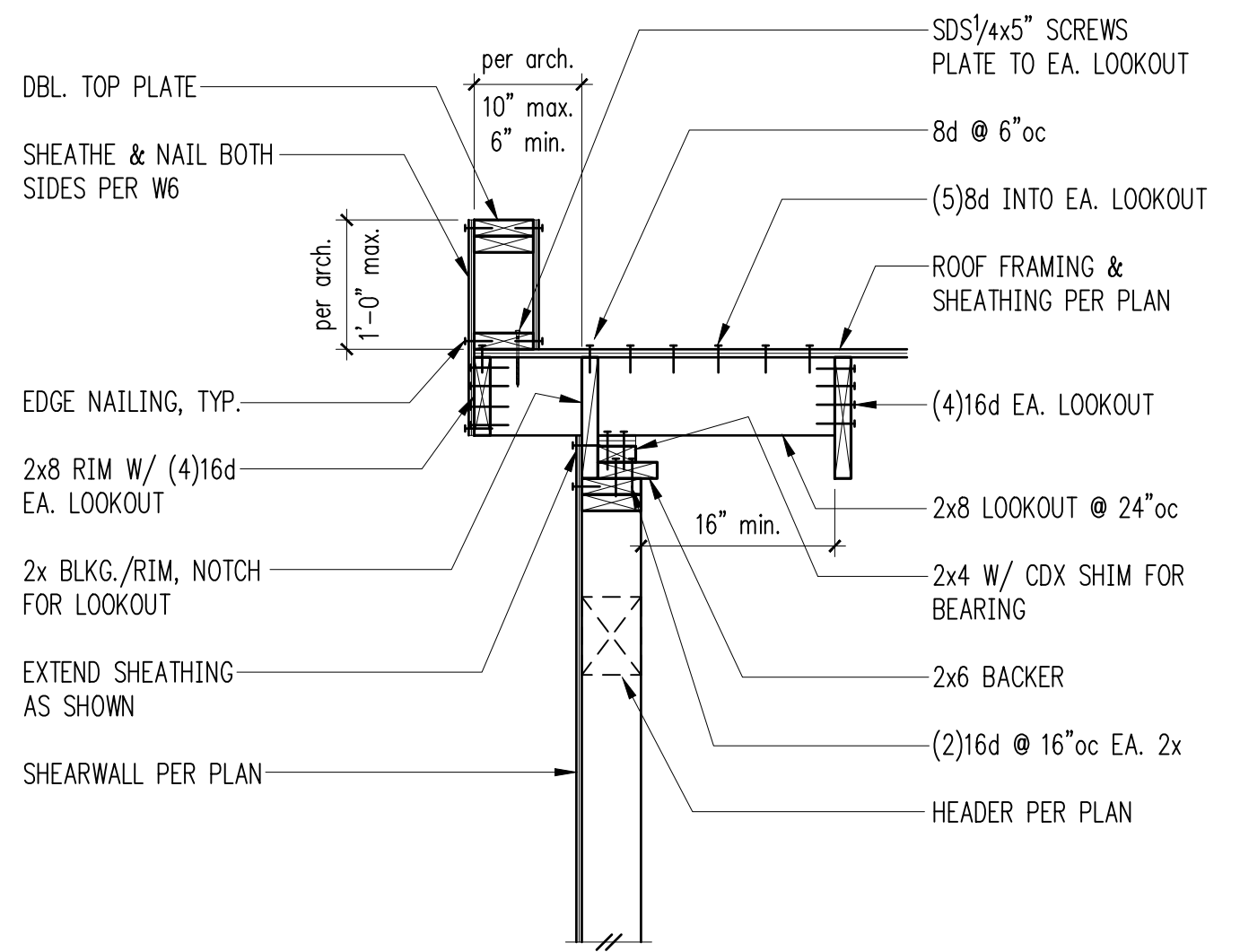

3 5

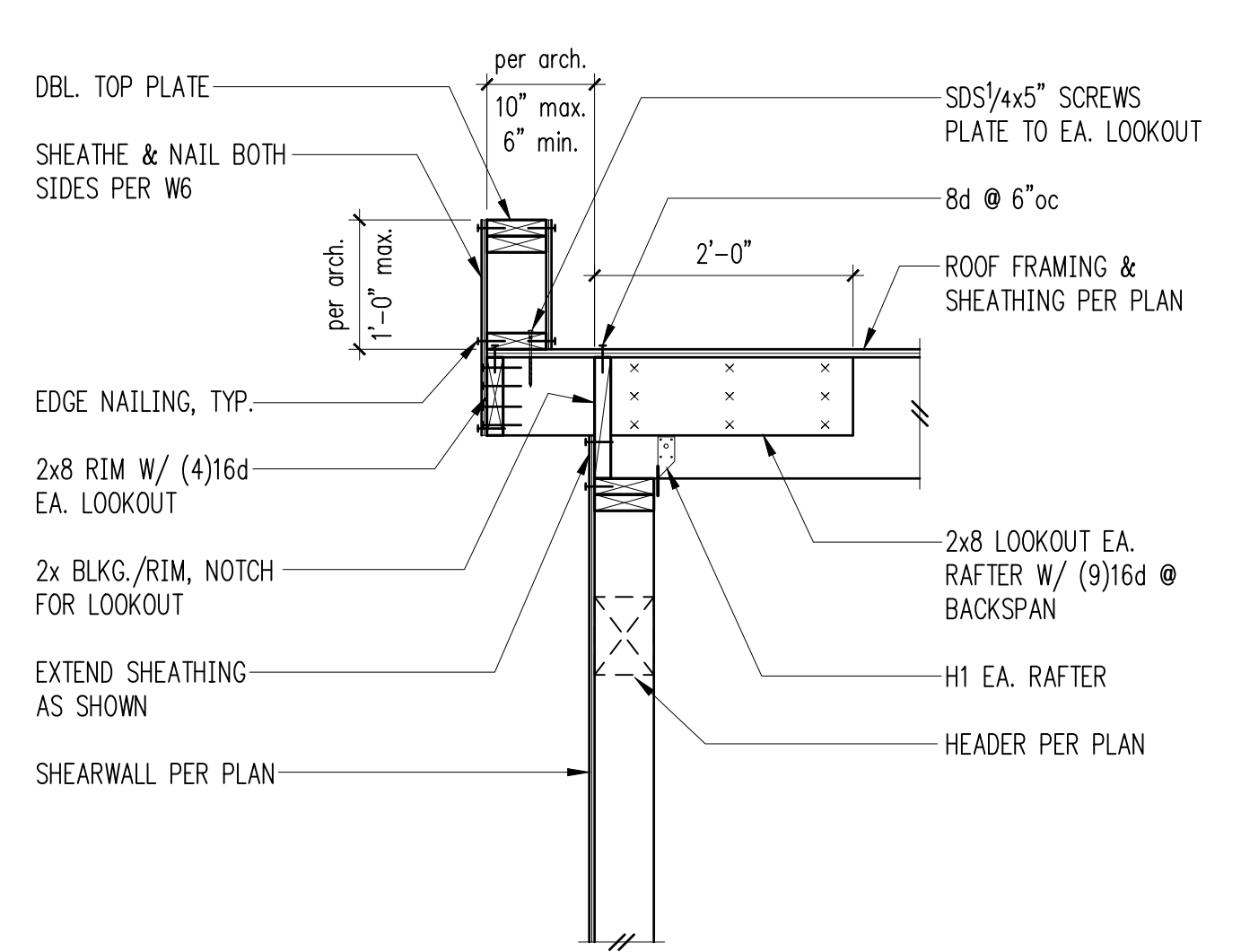

3 6

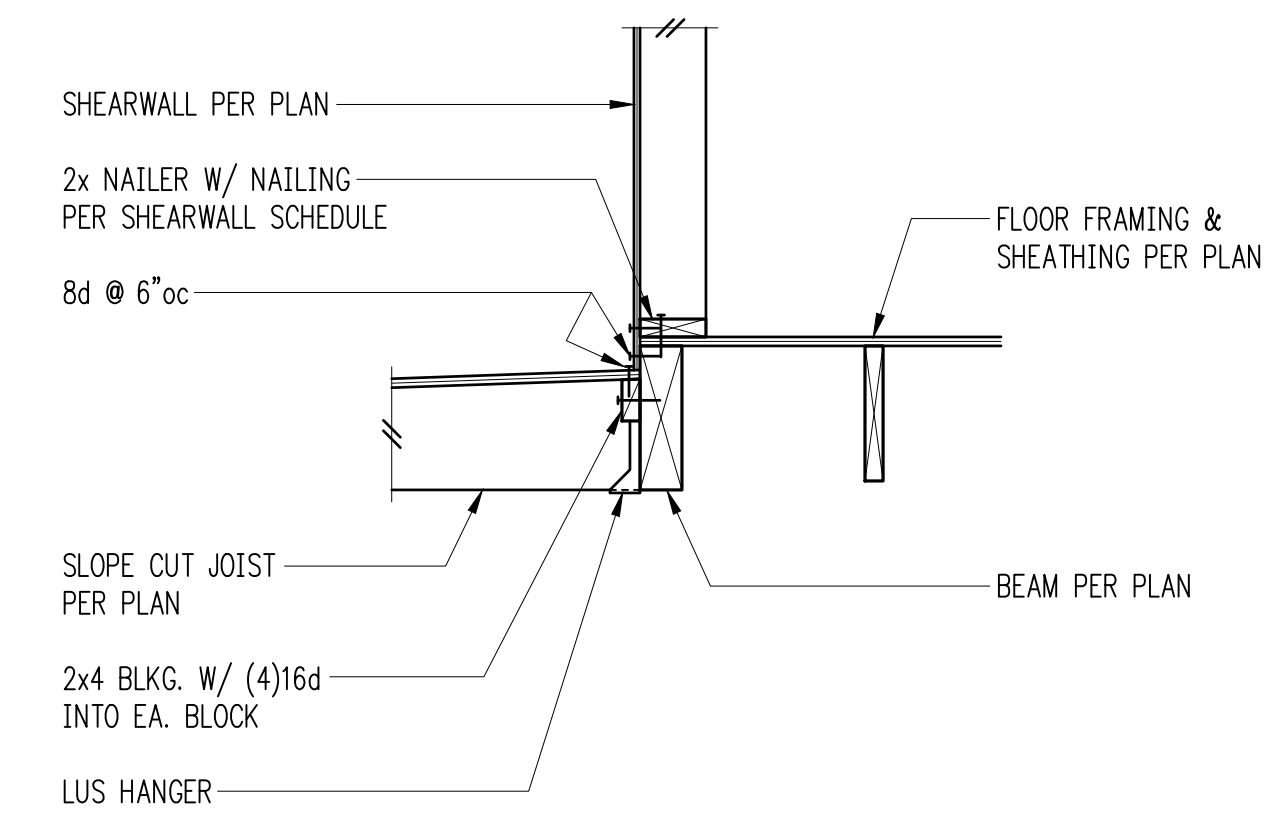

7

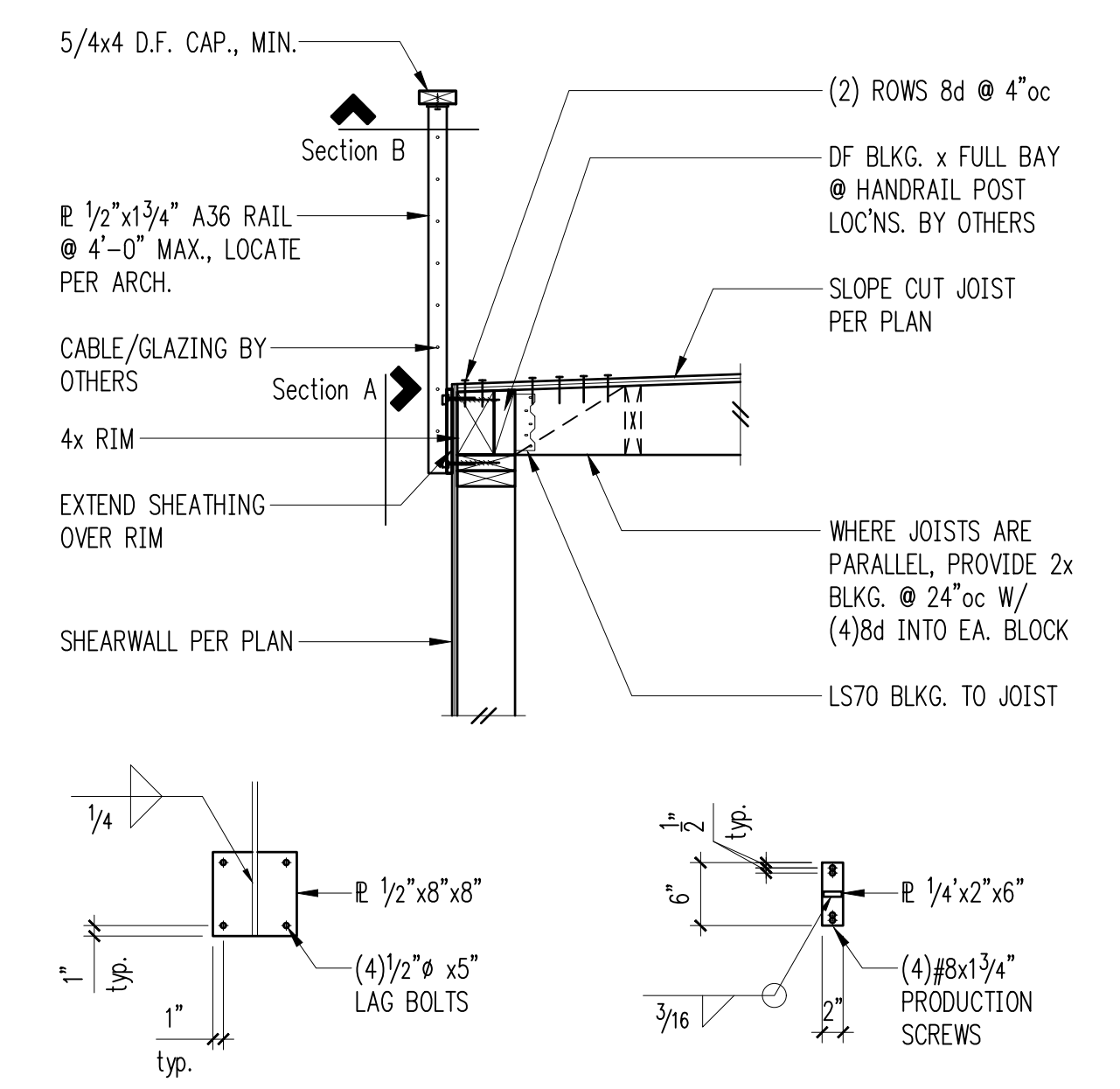

Section A

Section B

8

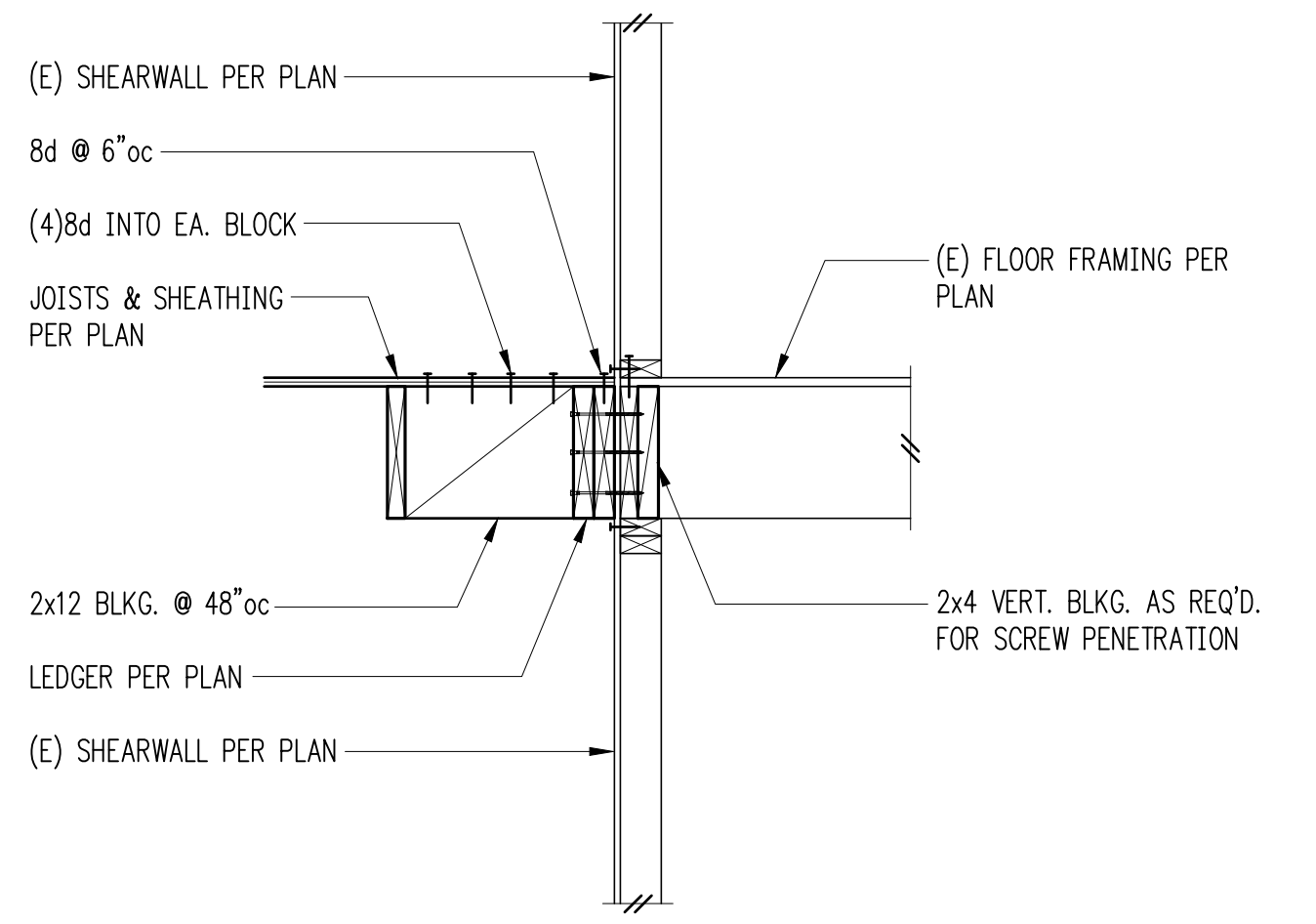

9

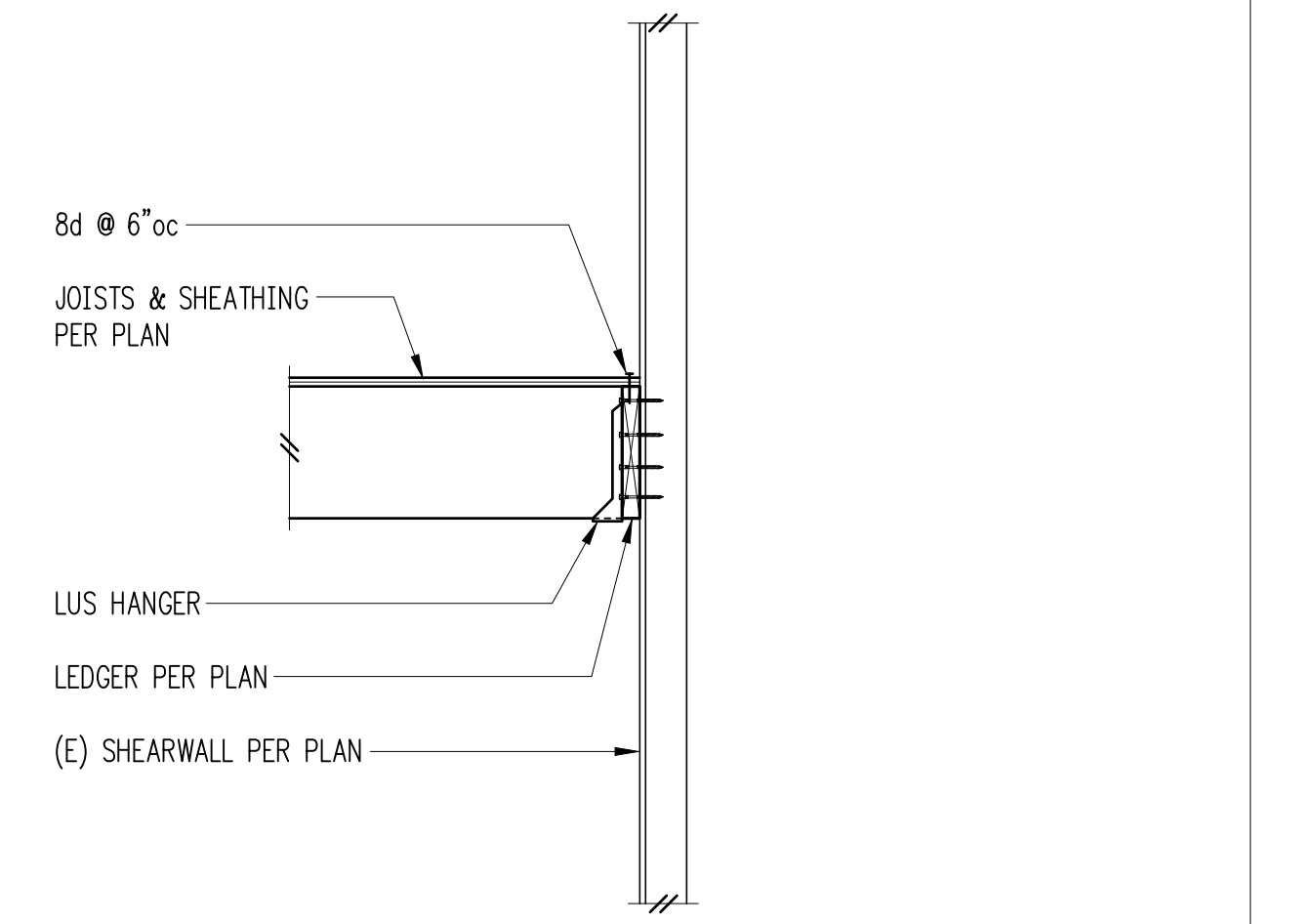

10

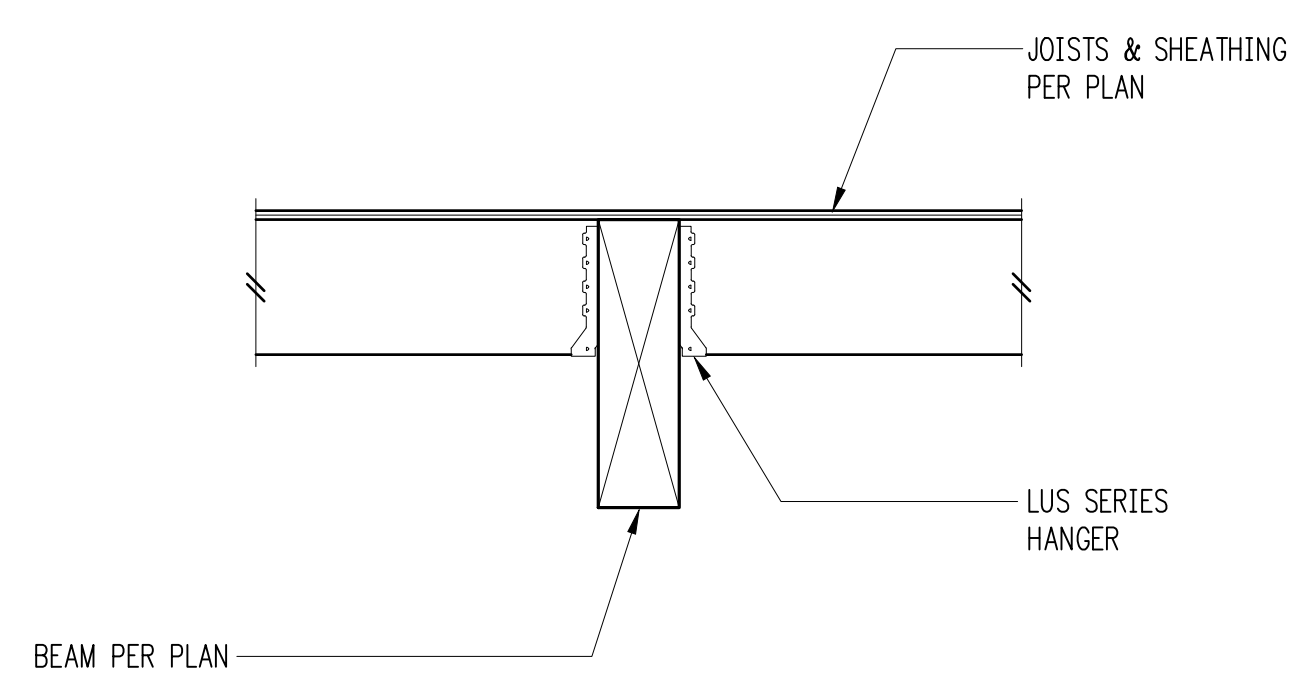

Typical Flush Beam 11

	A	B	C
PLAN VIEW			
SECTION			
# OF WOOD BMS (LVL)	2-1 3/4"	3-1 3/4"	4-1 3/4"
SDS SCREW SIZE	1/4" x 3/2"	1/4" x 4/2"	1/4" x 6"
# OF SDS SCREWS	2	2	2
SPACING OF SDS SCREWS	16" oc	8" oc	6" oc
HANGER (U.N.O.)	HU 48	WPU 5,50/7,25	HWU 7,12/7,25
MIN POST (U.N.O.)	(2) 2x4 (2) 2x6	(3) 2x4 (3) 2x6	(4) 2x4 (4) 2x6

NOTES:
 - MIN. SCREW END DISTANCE = 4"

Sistering Schedule for Multi Beams 12