

**project description:**

ADDITION OF NEW 22'-5X12'-0" ADDITION RESULTING IN 539 SQ. FT. OF ADDITIONAL HEATED LIVING SPACE. EXISTING DECK TO BE REPLACED WITH THE ADDITION OF A COVERED DECK

**project team:**

<b>owner</b>	HERITAGE HOMES 10 LLC 8028 SE 36TH ST MERCER ISLAND, 98040 (425) 443-3192	<b>structural engineer</b>	MANS THURFJELL, PE L120 ENGINEERING AND DESIGN 16329 118TH LN NE BOTHELL, WA 98011 MTHURFJELL@L120ENGINEERING.COM (206) 790-9502
<b>architectural drafter</b>	GREG KRUEGER KRUEGER KRAFTING LLC 22901 58TH AVE. W MOUNTLAKE TERRACE, WA 98043 GREG@KRUEGERKRAFTING.COM (206) 819-2710		

**sheet index:**

- SP1 SITE PLAN
- A1 FOUNDATION PLAN
- A2 BASEMENT FLOOR PLAN
- A3 MAIN FLOOR FRAMING
- A4 MAIN FLOOR PLAN
- A5 ROOF FRAMING PLAN
- A6 ELEVATIONS
- E1 BASMENT FLOOR ELECTRICAL
- E2 MAIN FLOOR ELECTRICAL
- D1 DETAILS
- S-0 STRUCTURAL COVER
- S-1 GENERAL STRUCTURAL NOTES
- S-2 BASEMENT / FOUNDATION PLAN
- S-3 BASEMENT FLOOR WALL FRAMING AND SHEAR PLAN
- S-4 MAIN FLOOR FRAMING PLAN
- S-5 MAIN FLOOR WALL FRAMING AND SHEAR PLAN
- S-6 ROOF FRAMING
- SD-1 STRUCTURAL DETAILS
- SD-2 STRUCTURAL DETAILS

**project data**

**property address**

8028 SE 36TH ST  
MERCER ISLAND, 98040

**tax account #:**

445830-0280

**existing legal description**

FROM KING COUNTY PARCEL OF RECORDS:  
LUCAS HILL DIV # 5  
PLat Block:  
Plat Lot: 28

OCCUPANCY ZONE: R-3  
RSA-4  
LOT SIZE = 0.22 ACRES = 9,725 S.F.

23.44.010	LOT COVERAGE	
	HOUSE	1,880 S.F.
	HOUSE ADDITIONS	269 S.F.
	COVERED DECK	156 S.F.
	TOTAL	2,305 S.F.

IMPERVIOUS SURFACES	
1. BUILDING FOOTPRINT (INCLUDES OVERHANGS) =	2,278 S.F.
2. PROPOSED ADDITIONS =	486 S.F.
3. DRIVE / WALK =	418 S.F.
TOTAL	3,182 S.F.

**average grade calculation**

wall segment length		wall segment elev.	
Mark	Length	Mark	Elev.
a	69.00	A	199.05
b	43.00	B	203.70
c	69.00	C	206.40
d	43.00	D	197.60

(axA) = 13734.45  
(bxB) = 8759.10  
(cxC) = 14241.60  
(dxD) = 8496.80

45231.95 Total  
224.00 Total Wall Distance  
201.93 Average Grade  
30 Building Height  
231.93 Total Height Limit

AVERAGE GRADE LEVEL  
 $\frac{(\text{length of wall}) \times (\text{midpoint elevation})}{(\text{total length of wall segments})}$

$\frac{(a \times A) + (b \times B) + (c \times C) + (d \times D)}{A + B + C + D} = \frac{45231.95}{224.00} = 201.93$

"A" length:	69.00	"B" length:	43.00
"A" Elev.:	199.05	"B" Elev.:	203.70
"C" length:	69.00	"D" length:	43.00
"C" Elev.:	206.40	"D" Elev.:	197.60

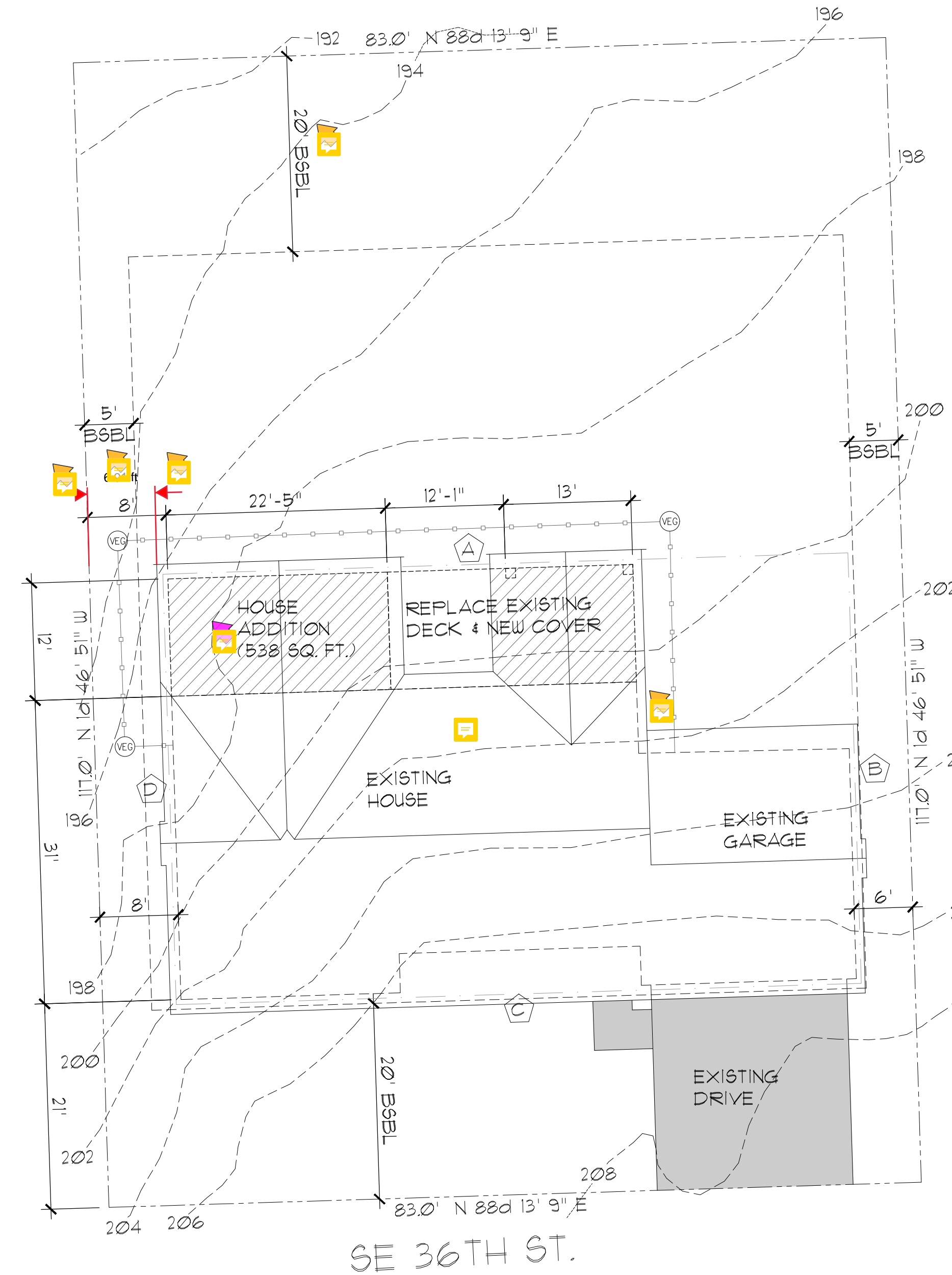
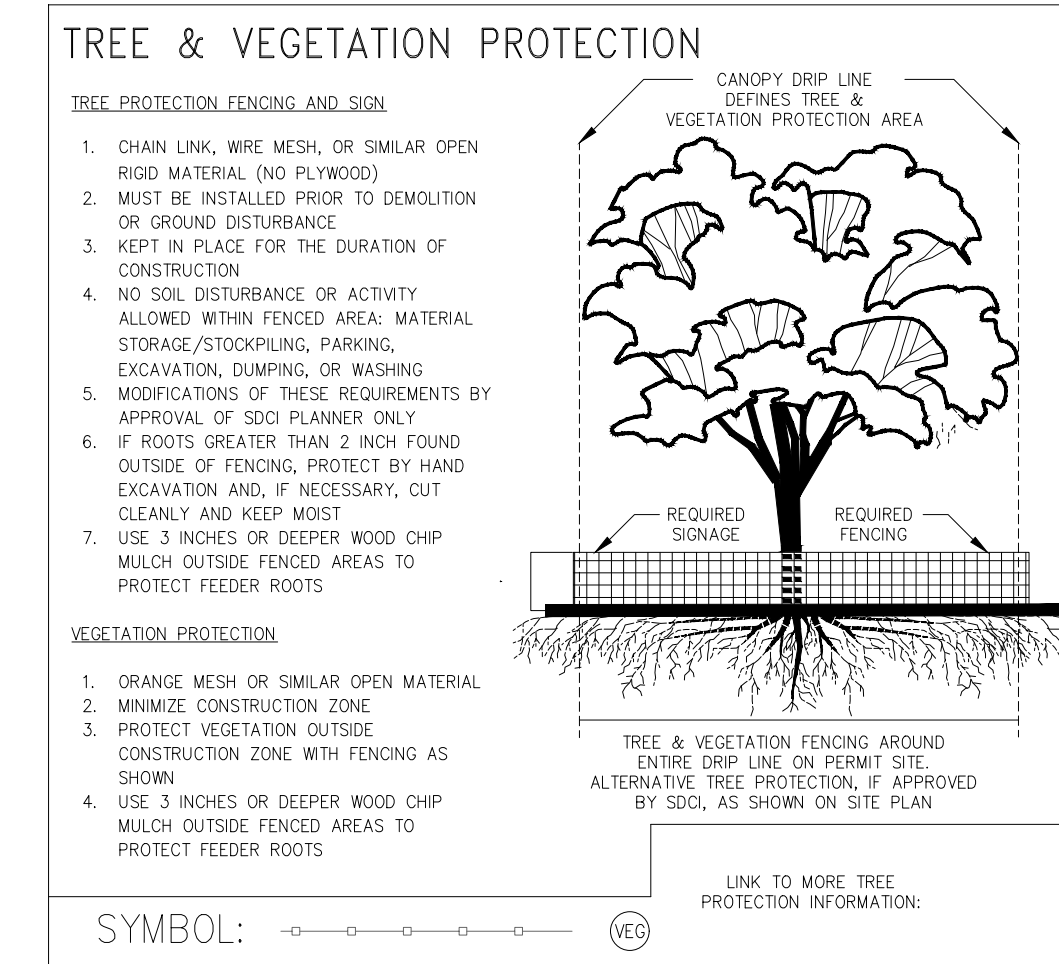

**QUI SITE PLAN**  
SCALE: 1" = 10'-0"  
N

PLAN DATE: ENCL. # & NAME: DESCRIPTION: ENCL. # & NAME: DESCRIPTION:

**Krueger KRAFTING**  
GREG KRUEGER  
206-819-2710  
greg@kruegerkrafting.com

PLAN: QUI REMODEL  
8028 SE 36TH ST.  
MERCER ISLAND, WA 98040  
SITE PLAN

FILE NO.  
20-39

SHEET  
SP1

**tree impact**

THERE ARE NO SIGNIFICANT TREES THAT ARE AFFECTED BY THE ADDITION ON TO THE EXISTING SINGLE FAMILY RESIDENCE.

**TYPICAL FOUNDATION NOTES**

1. SEE MAIN FLOOR FRAMING FOR FLOOR JOISTS CALL-OUTS.
2. USE 4x4 DFP2 POSTS UNDER ALL BEAMS (4x6 @ SPLICE LOCATIONS), TYP. UNO.
3. SEE S-SHEETS FOR TYP. PONY WALL CONSTRUCTION AND HOLDOWN @ PONY WALLS.
4. SILL PLATES AND POSTS MUST BE 6" ABOVE EXPOSED EARTH. (BEAMS MUST BE 12" AND TRUSSES 18"). WOOD FRAMING IN CONTACT WITH CONCRETE TO BE PRESSURE TREATED OR SEPARATED WITH AN APPROVED VAPOR BARRIER.
5. PROVIDE 6 MIL. BLACK POLYETHYLENE VAPOR BARRIER OVER ENTIRE CRAWL SPACE, LAP EDGES 12" MIN.
6. FOOTINGS SHALL BEAR ON FIRM, UNDISTURBED SOIL AT LEAST 18" BELOW FINISHED ADJACENT GRADE AT EXTERIOR.
7. PROVIDE TEMPORARY BRACING AS REQUIRED UNTIL ALL PERMANENT CONNECTIONS AND STIFFENERS HAVE BEEN INSTALLED.
8. WRITTEN DIMENSIONS TAKE PRECEDENCE OVER SCALED DIMENSIONS. VERIFY ALL DIMENSIONS AND CONDITIONS IN THE FIELD.
9. STANDARD FTG. SHALL BE 6"x6" x 12" UNO CONTINUOUS. STANDARD STEM WALL SHALL BE 6" THICK, HORIZ. & VERT. REINFORCEMENT PER PLAN.
10. 2x6 (56X) FT. SILL PLATE (SODIUM BORATE PRESSURE TREATED) WITH ANCHOR BOLTS PER SHEAR SCHEDULE AND 3"x3"x0.225" PLATE WASHERS. EMBED ANCHOR BOLTS 1" MINIMUM INTO CONC.
11. SLOPE GARAGE SLAB 1/8" (3" MIN) PER FOOT TOWARD DOORS
12. SLOPE ALL PORCHES, PATIOS, STAIRS AND HARD-SCAPE MATERIAL AWAY FROM BUILDING MIN. 1/4" PER FOOT - TYP.
13. PROVIDE 1x4 SLEEPERS AT RAISED STEM WALLS WHERE SIDING EXTEND TO 6" (MIN) ABOVE GARAGE, 2" (MIN) ABOVE CONCRETE HARDSCAPE, ALSO AT FRONT FOR GARAGE DOOR LINER INSTALL.

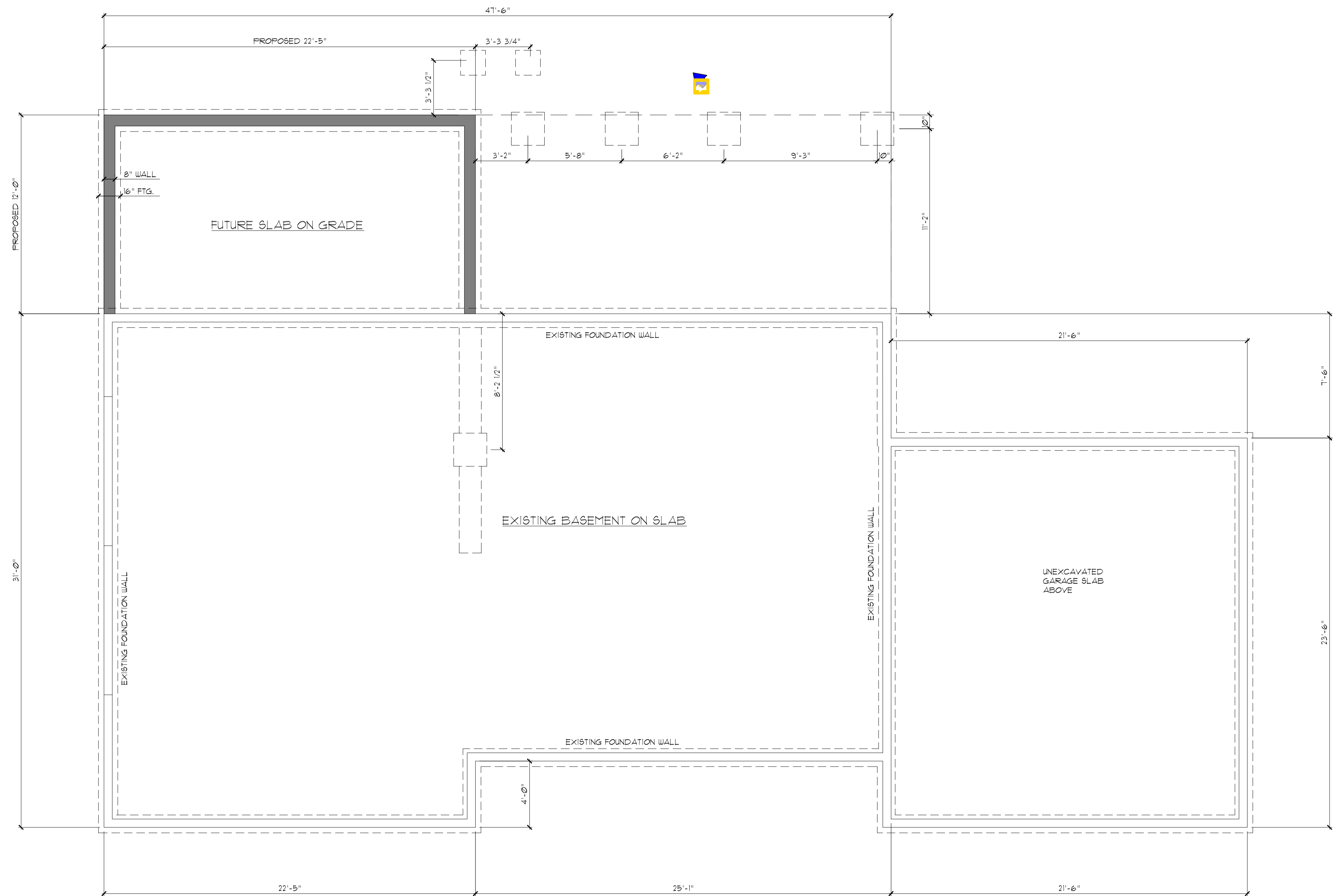

**foundation plan**  
1/4" = 1'-0"

PLAN DATE: ENS. # & NAME: DESCRIPTION:  
ENS. # :

PLAN: GJI REMODEL  
8028 SE 36TH ST.  
MERCER ISLAND, WA 98040  
FOUNDATION PLAN

**Kraefting**  
RUEGER  
GREG KRUEGER  
206-819-2710  
greg@kruegerkrafting.com

FILE NO.  
20-39

SHEET  
A1

**MAIN FLOOR PLAN NOTES**

1. SEE UPPER FLOOR FRAMING FOR ALL HEADER & BEAM CALL-OUTS
2. ALL WINDOWS SHALL COMPLY W/ W.S.E.C. FRAMERS TO VERIFY ROUGH OPENINGS.
3. VENT ALL FANS AND DRYER EXHAUST TO OUTSIDE. PROVIDE 2x BLOCKING EACH SIDE OF FAN. HOLD BLOCKING 1/4" UP FROM GUB.
4. TOILET PAPER DISPENSERS TO BE MOUNTED @ 21" AFF. (TYP.)
5. ALL TOILET BARS MOUNTED @ 42" AFF. UNO.
6. PROVIDE TEMPORARY BRACING AS REQUIRED UNTIL ALL CONNECTIONS AND STIFFENERS HAVE BEEN INSTALLED.
7. WRITTEN DIMENSIONS TAKE PRECEDENCE OVER SCALED DIM'S. VERIFY ALL DIMENSIONS AND CONDITIONS IN THE FIELD.
8. CO-CARBON MONOXIDE ALARM & SMOKE DETECTOR
9. 10V SMOKE DETECTOR W/ BATTERY BACKUP AND INTERCONNECTED ALARMS R314 IRC.
10. SHOWER WALLS SHALL BE WATERPROOF TO A MIN. 12" AFF.
11. ALL BATHROOM GLAZING INCLUDING WINDOWS WITHIN 60" OF A STANDING OR A WALKING SURFACE SHALL HAVE SAFETY GLAZING.

- 1 HOSE BIBB AND WATER SHUTOFF LOCATED AT REAR GARAGE WALL TO BE INSTALLED IN CLOSE PROXIMITY TO EACH OTHER AND TO LINE UP BELOW TUB.
- 2 HOT AND COLD BIB @ 48" AFF. @ UTILITY ROOM
- 3 RANGE HOOD WITH DISCHARGE TO OUTDOORS WITH DUCT AND DAMPER REQUIREMENTS PER 1503.4 IRC. SYSTEM TO BE INDEPENDENT OF ALL OTHER EXHAUST SYSTEMS. 100 CFM MIN. 400 CFM MAX. UNLESS DEDICATED MAKEUP AIR IS PROVIDED IN THE SAME ROOM.  
1/2" GYPSUM WALL BOARD ON ALL WALLS, POSTS AND BEAMS. 5/8" TYPE 'X' GYPSUM WALL BOARD ON CEILINGS AND BEAMS. 5/8" TYPE 'X' G.W.B. SHALL BE INSTALLED PERPENDICULAR TO THE CEILING FRAMING AND SHALL BE FASTENED AT MAX. 6 INCHES O.C. FASTENERS PER TABLE R102.3.5.
- 4 DIRECT VENT GAS METAL FIREPLACE. INSTALL PER MANUF. SPECIFICATIONS. PROVIDE 6" dia. OUTSIDE COMBUSTION AIR.
- 5 LOW FLOW FIXTURES TO SAVE A MINIMUM OF 20% OF WATER OVER CONVENTIONAL FIXTURES.
- 6 FUEL BURNING EQUIPMENT LOCATED WITHIN THE BUILDING ENVELOPE (CONSTRUCTED UNDER THE W.S.E.C.) SHALL OBTAIN COMBUSTION AIR FROM OUTDOORS, MEETING THE PROVISIONS OF SECTION M102.11.1.1.1.C.

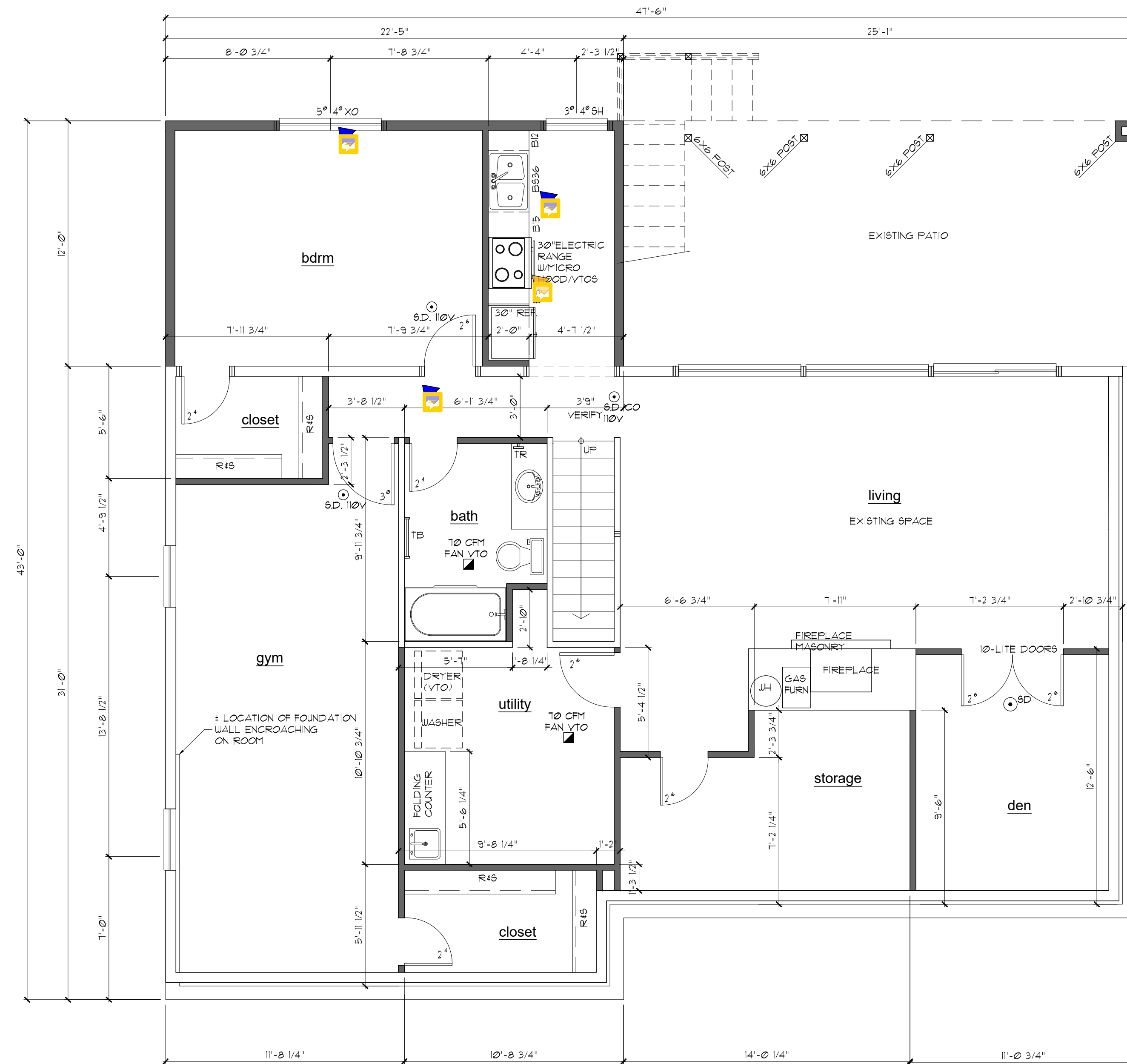

**basement floor plan**  
1/4" = 1'-0"

- LEGEND**
- PROPOSED WALLS
  - - - EXISTING WALLS TO REMAIN
  - · · EXISTING WALLS TO BE REMOVED

PLAN DATE: ENS. # NAME: DESCRIPTION:  
ENS. # :

PLAN: GVI REMODEL  
8028 SE 36TH ST.  
MERCER ISLAND, WA 98040  
BASEMENT FLOOR PLAN

**Krafft**  
RUEGER  
GREG KRUEGER  
206-819-2710  
greg@kruegerkrafting.com

FILE NO.  
20-39

SHEET  
A2

**MAIN FLOOR FRAMING NOTES**

1. FOUNDATION BEAMS SHALL BE 4X10 DF2, TYP. UNO.
2. RIM JOISTS SHALL BE 2X10DF2 (UNO).
3. |—| INDICATES 14"x1" SCREENED FOUNDATION VENTS CUT INTO RIM JOISTS TYPICAL. SEE FOUNDATION SHEET FOR CRAWL-SPACE VENTILATION CALCULATIONS.
4. FLOOR SHEATHING SHALL BE 3/8" T&G OSB. APPLY w/ LONG DIMENSION ACROSS JOISTS. STAGGER END JOINTS. GLUE AND NAIL @ ALL PANEL EDGES AND OVER ALL SHEAR WALLS w/ 8d @ 6" o.c. AND OVER ALL INTERMEDIATE FRAMING @ 12" o.c.
5. VERIFY ALL PLUMBING DROPS.
6. SEE FOUNDATION PAGE 4 ENGINEER OF RECORD FOR TYPICAL PONY WALL DETAILS.
7. PROVIDE TEMPORARY BRACING AS REQUIRED UNTIL ALL PERMANENT CONNECTIONS AND STIFFENERS HAVE BEEN INSTALLED.
8. WRITTEN DIMENSIONS TAKE PRECEDENCE OVER SCALED DIMENSIONS. VERIFY ALL DIMENSIONS AND CONDITIONS IN THE FIELD.
11. PROVIDE INSULATION Baffles AT ALL FOUNDATION VENTS @ AN ANGLE OF 30 DEGREES FROM HORIZONTAL.

1 FRAME OUT FOR 18"x24" CRAWL SPACE ACCESS WEATHER STRIPPING.

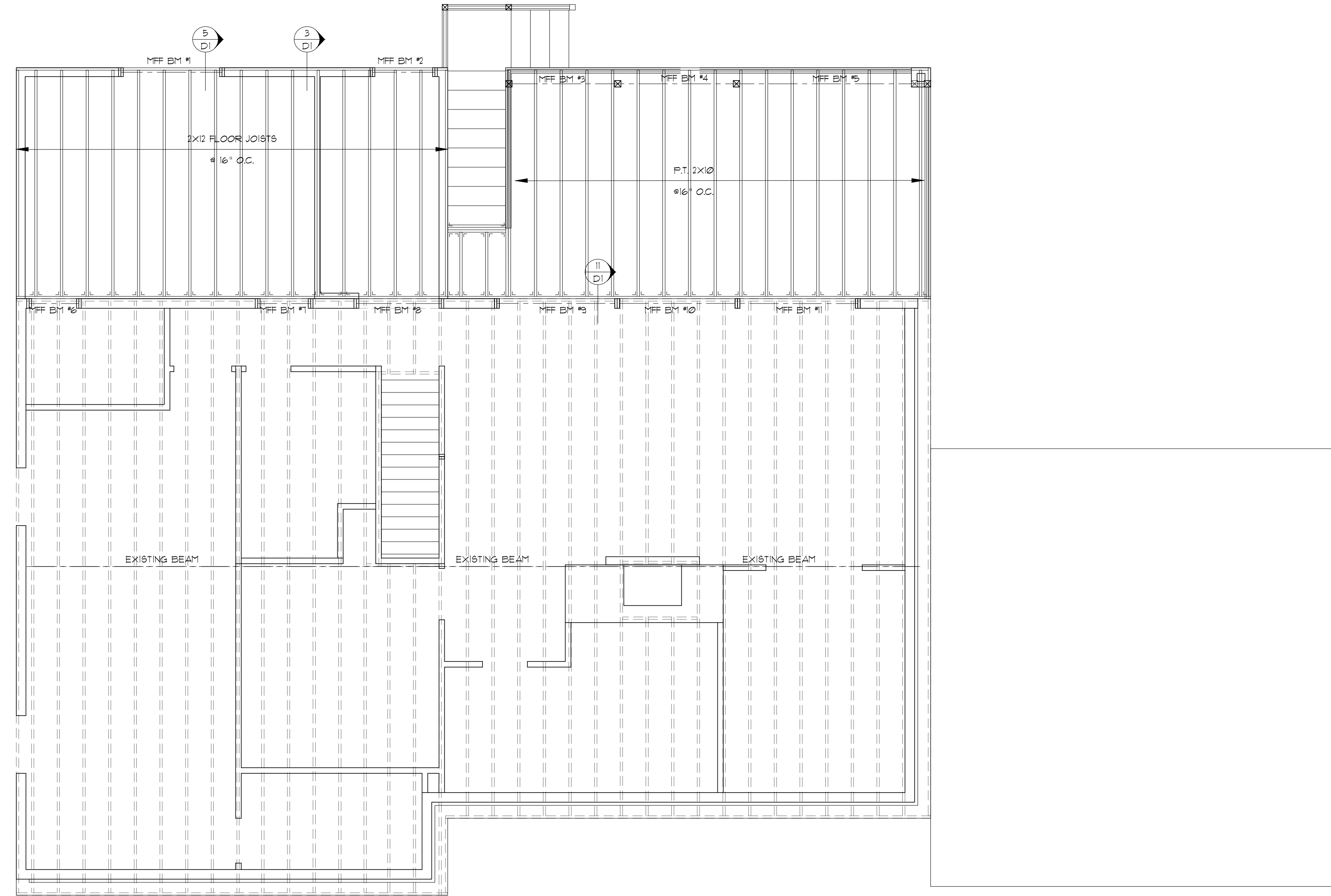

**main floor framing plan**  
1/4" = 1'-0"

PLAN DATE: ENS. # & NAME: DESCRIPTION:  
ENS. # :

PLAN: GJI REMODEL  
8028 SE 36TH ST.  
MERCER ISLAND, WA 98040  
MAIN FLOOR FRAMING PLAN

**Krafter**  
RUEGER  
GREG KRUEGER  
206-819-2710  
greg@kruegerkrafting.com

FILE NO.  
20-39

SHEET  
A3

**MAIN FLOOR PLAN NOTES**

- SEE UPPER FLOOR FRAMING FOR ALL HEADER & BEAM CALL-OUTS
- ALL WINDOWS SHALL COMPLY W/ W.S.E.C. FRAMERS TO VERIFY ROUGH OPENINGS
- VENT ALL FANS AND DRYER EXHAUST TO OUTSIDE. PROVIDE 2x BLOCKING EACH SIDE OF FAN. HOLD BLOCKING 1/4" UP FROM GUEB.
- TOILET PAPER DISPENSERS TO BE MOUNTED @ 21" AFF. (TYP.)
- ALL TOILET BARS MOUNTED @ 42" AFF. UNO
- PROVIDE TEMPORARY BRACING AS REQUIRED UNTIL ALL CONNECTIONS AND STIFFENERS HAVE BEEN INSTALLED.
- WRITTEN DIMENSIONS TAKE PRECEDENCE OVER SCALED DIM'S. VERIFY ALL DIMENSIONS AND CONDITIONS IN THE FIELD.
- CO-CARBON MONOXIDE ALARM & SMOKE DETECTOR
- 100% SMOKE DETECTOR W/ BATTERY BACKUP AND INTERCONNECTED ALARMS 9314 IRC.
- SHOWER WALLS SHALL BE WATERPROOF TO A MIN. 12" AFF.
- ALL BATHROOM GLAZING INCLUDING WINDOWS WITHIN 60" OF A STANDING OR A WALKING SURFACE SHALL HAVE SAFETY GLAZING.

- 1 HOSE BIBB AND WATER SHUTOFF LOCATED AT REAR GARAGE WALL TO BE INSTALLED IN CLOSE PROXIMITY TO EACH OTHER AND TO LINE UP BELOW TUB.
- 2 HOT AND COLD BIB @ 48" AFF. # UTILITY ROOM
- 3 RANGE HOOD WITH DISCHARGE TO OUTDOORS WITH DUCT AND DAMPER REQUIREMENTS PER 1503.4 IRC. SYSTEM TO BE INDEPENDENT OF ALL OTHER EXHAUST SYSTEMS. 100 CFM MIN. 400 CFM MAX. UNLESS DEDICATED MAKEUP AIR IS PROVIDED IN THE SAME ROOM.
- 4 1/2" GYPSUM WALL BOARD ON ALL WALLS, POSTS AND BEAM. 5/8" TYPE 'X' GYPSUM WALL BOARD ON CEILING AND BEAMS. 5/8" TYPE 'X' GYPSUM SHALL BE INSTALLED PERPENDICULAR TO THE CEILING FRAMING AND SHALL BE FASTENED AT MAX. 6 INCHES O.C. FASTENERS PER TABLE R102.3.5.
- 5 DIRECT VENT GAS METAL FIREPLACE. INSTALL PER MANUF. SPECIFICATIONS. PROVIDE 6" dia. OUTSIDE COMBUSTION AIR.
- 6 LOW FLOW FIXTURES TO SAVE A MINIMUM OF 20% OF WATER OVER CONVENTIONAL FIXTURES.
- 7 FUEL BURNING EQUIPMENT LOCATED WITHIN THE BUILDING ENVELOPE (CONSTRUCTED UNDER THE W.S.E.C.) SHALL OBTAIN COMBUSTION AIR FROM OUTDOORS, MEETING THE PROVISIONS OF SECTION M101.1 IRC.

**ENERGY CREDITS**

2. MEDIUM DWELLING UNIT: 3.5 CREDITS  
ALL DWELLING UNITS THAT ARE NOT INCLUDED IN 1 OR 3

PER TABLE R402.2 SUMMARY			
#	OP.	DESCRIPTION	CREDIT(S)
1.	1a	EFFICIENT BUILDING ENVELOPE 1a	0.5
2.	2a	AIR LEAKAGE CONTROL AND EFF. VENTING	0.5
3.	3a	HIGH EFFICIENCY HVAC 3a	1.0
4.	4	HIGH EFFICIENCY HVAC DIST. SYSTEM	1.0
5.	5a	EFFICIENT WATER HEATING 5a	0.5
TOTAL:			3.5

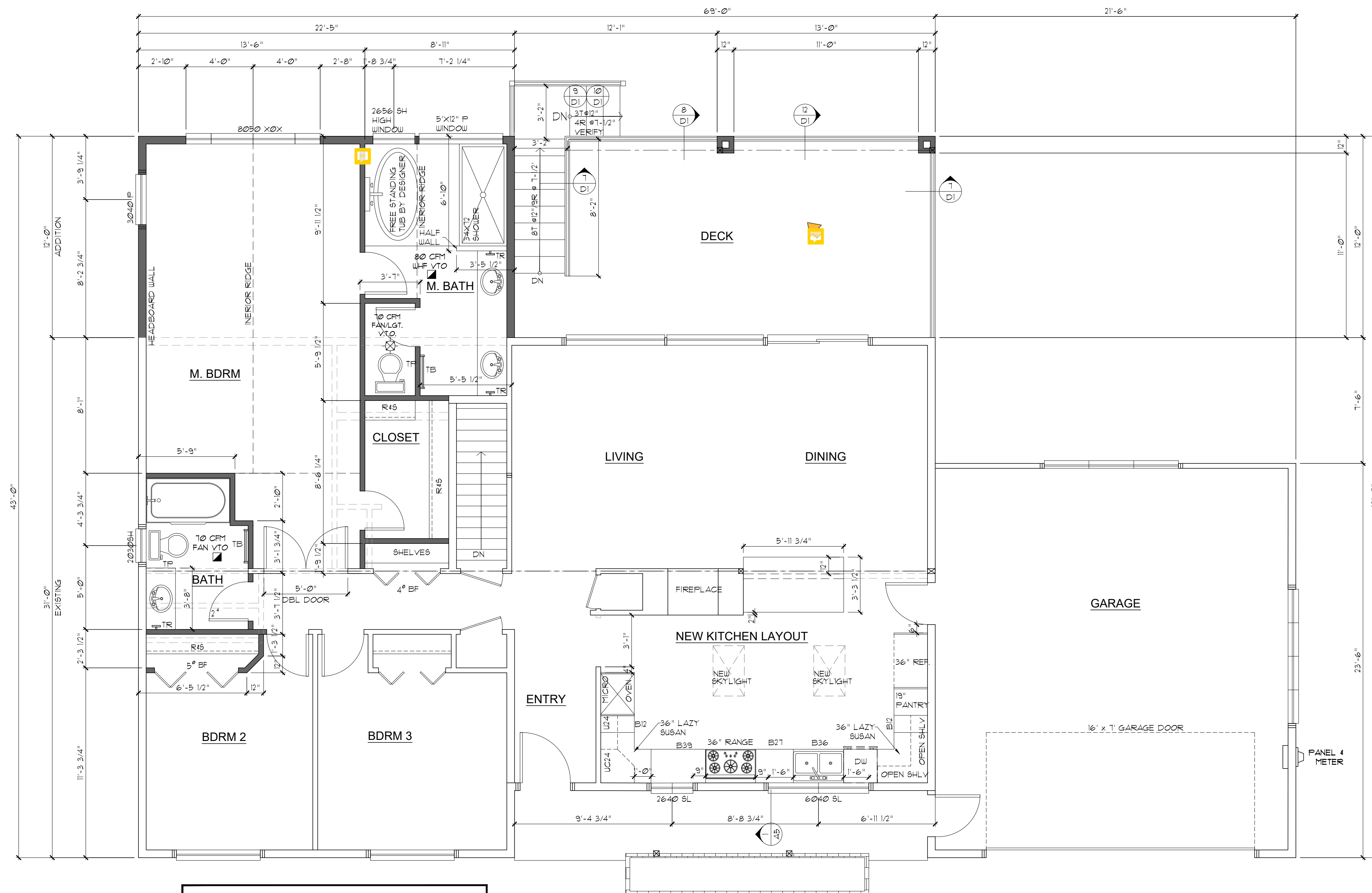
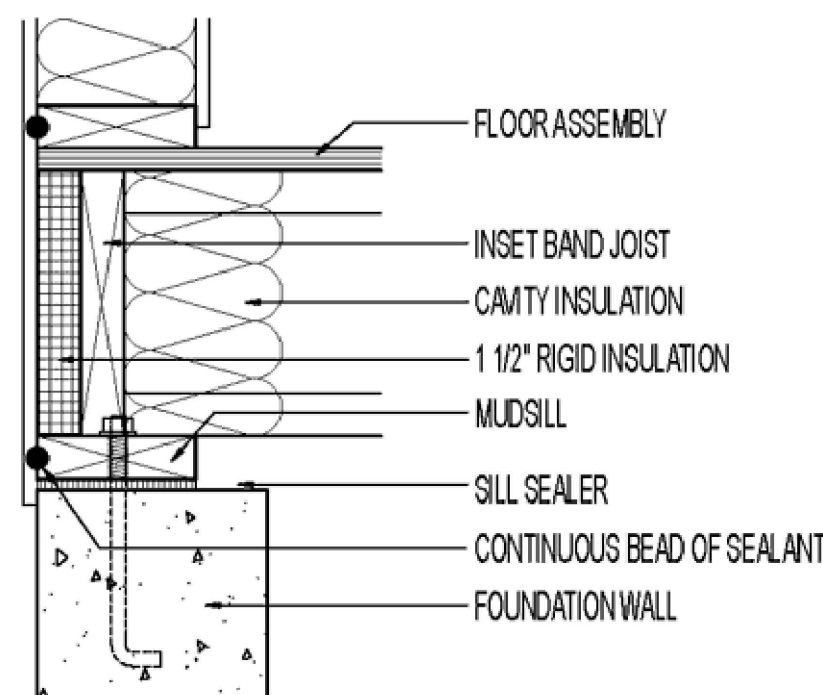

**AREA CALCULATION:**

EXISTING BASEMENT FLOOR:	1,320 SQ. FT.
PROPOSED BASEMENT FLOOR:	269 SQ. FT.
TOTAL BASEMENT FLOOR:	1,589 SQ. FT.
EXISTING MAIN FLOOR:	1,372 SQ. FT.
PROPOSED MAIN FLOOR:	269 SQ. FT.
TOTAL MAIN FLOOR:	1,641 SQ. FT.
TOTAL SQ. FOOTAGE:	3,230 SQ. FT.
GARAGE:	510 SQ. FT.
COVERED DECK:	156 SQ. FT.
DECK:	145 SQ. FT.

**main floor plan**

1/4" = 1'-0"

- LEGEND**
- PROPOSED WALLS
  - - - EXISTING WALLS TO REMAIN
  - EXISTING WALLS TO BE REMOVED

PLAN DATE: ENS. # NAME: DESCRIPTION:  
ENS. # :

PLAN: QUI REMODEL  
8028 SE 36TH ST.  
MERCER ISLAND, WA 98040  
MAIN FLOOR PLAN

**KRUEGER**  
**Krafting**  
GREG KRUEGER  
206-819-2710  
greg@kruegerkrafting.com

FILE NO.  
20-39

SHEET  
A4

**ROOF PLAN NOTES**

- ALL BEAMS AND HEADERS ARE 4x8 DF#2 (TYP. UNO.)
- PRE-MANUFACTURED WOOD TRUSSES @ 24" O.C. (TYP. UNO.)
- PROVIDE SIMPSON HI HURRICANE TIE @ EACH END OF TRUSS. PROVIDE (2) H2B's @ EACH END OF 2-PLY AND GREATER GIRDER TRUSSES/SIMPSON HARDWARE OR EQUIV.)
- ROOF SHEATHING SHALL BE 7/8" T&G OSB APPLIED w/ LONG DIMENSION ACROSS TRUSSES OR RAFTERS. STAGGER END JOINTS. @ COMMON NAIL @ 6" O.C. ALL PANEL EDGES AND OVER ALL SHEAR WALLS AND DRAG TRUSSES w/ 2x4 NAILS @ 12" O.C. @ FIELD.
- PROVIDE TEMPORARY BRACING AS REQUIRED UNTIL ALL PERMANENT CONNECTIONS AND STIFFENERS HAVE BEEN INSTALLED.
- WRITTEN DIMENSIONS TAKE PRECEDENCE OVER SCALED DIMENSIONS. VERIFY ALL DIMENSIONS AND CONDITIONS IN THE FIELD.
- VENT (V.T.O.) CUT-OUT
- SHADE AREA INDICATES OVER-FRAMING.

**WOOD TRUSS NOTES**  
(PER I.R.C. SECTION R802.10.)

TRUSS DESIGN DRAWINGS SHALL BE PROVIDED WITH THE SHIPMENT OF TRUSSES DELIVERED TO THE JOB SITE AND SHALL BE ON THE JOB SITE.

ENGINEERING DATA AND DETAILS SHALL BE APPROVED BY THE BUILDING OFFICIAL BEFORE INSTALLATION.

TRUSSES SHALL BE DESIGNED BY A REGISTERED WASHINGTON STATE ENGINEER. STRESS ANALYSIS, DRAWINGS AND DETAILS SHALL BE STAMPED BY AN APPROVED STATE OF WASHINGTON REGISTERED ENGINEER AND FABRICATED FROM ONLY THESE DESIGNS.

ROOF TRUSSES SHALL BE FRAMED AND TIED INTO THE FRAMEWORK AND SUPPORTING WALLS SO AS TO FORM AN INTEGRAL PART OF THE WHOLE BUILDING.

ROOF TRUSSES SHALL HAVE JOINTS WELL FITTED AND SHALL HAVE TENSION MEMBERS WELL TIGHTENED BEFORE ANY LOAD IS PLACED UPON THE TRUSS. DIAGONAL AND SWAY BRACING SHALL BE USED TO BRACE ALL TRUSSES.

PRE-MANUFACTURED TRUSSES TO BE STAMPED BY THE MANUFACTURER OR BY A QUALITY CONTROL AGENCY SUCH AS THE WASHINGTON STATE TRUSS FABRICATORS COUNCIL. TRUSS INFORMATION PERMANENTLY AFFIXED TO EACH TRUSS SHALL CONTAIN TRUSS MANUFACTURER'S IDENTIFICATION, DESIGN LOAD AND TRUSS SPACING.

NONBEARING WALLS SHALL BE HELD AWAY FROM THE TRUSS BOTTOM CHORD WITH AN APPROVED FASTENERS TO ENSURE THAT THE TRUSS BOTTOM CHORD WILL NOT BEAR ON THE WALL.

ALL TRUSS BOTTOM CHORDS TO BE DESIGNED AS ATTICS WITHOUT STORAGE (10 PSF LL). TRUSSES SHALL BE DESIGNED WITH A BOTTOM CHORD OPENING LESS THAN 42"x24" WHERE (2) OR MORE ADJACENT TRUSSES HAVE THE SAME WEB CONFIGURATION.

**STICK BUILT OVER-FRAMING:**

- 2x4 HP#2 RAFTERS @ 24" o.c.
- 2x4 HP#2 POST SUPPORT FOR RAFTERS, STAGGER @ 48" O.C.
- BRACE POST OVER 6'-0" LONG (IN 2x PLAT DIRECTION) TO PREVENT BUCKLING

**D.S. LEGEND**

- D.S. = DOWNSPOUT TO GRADE
- D.S. = DOWNSPOUT TO LOWER ROOF

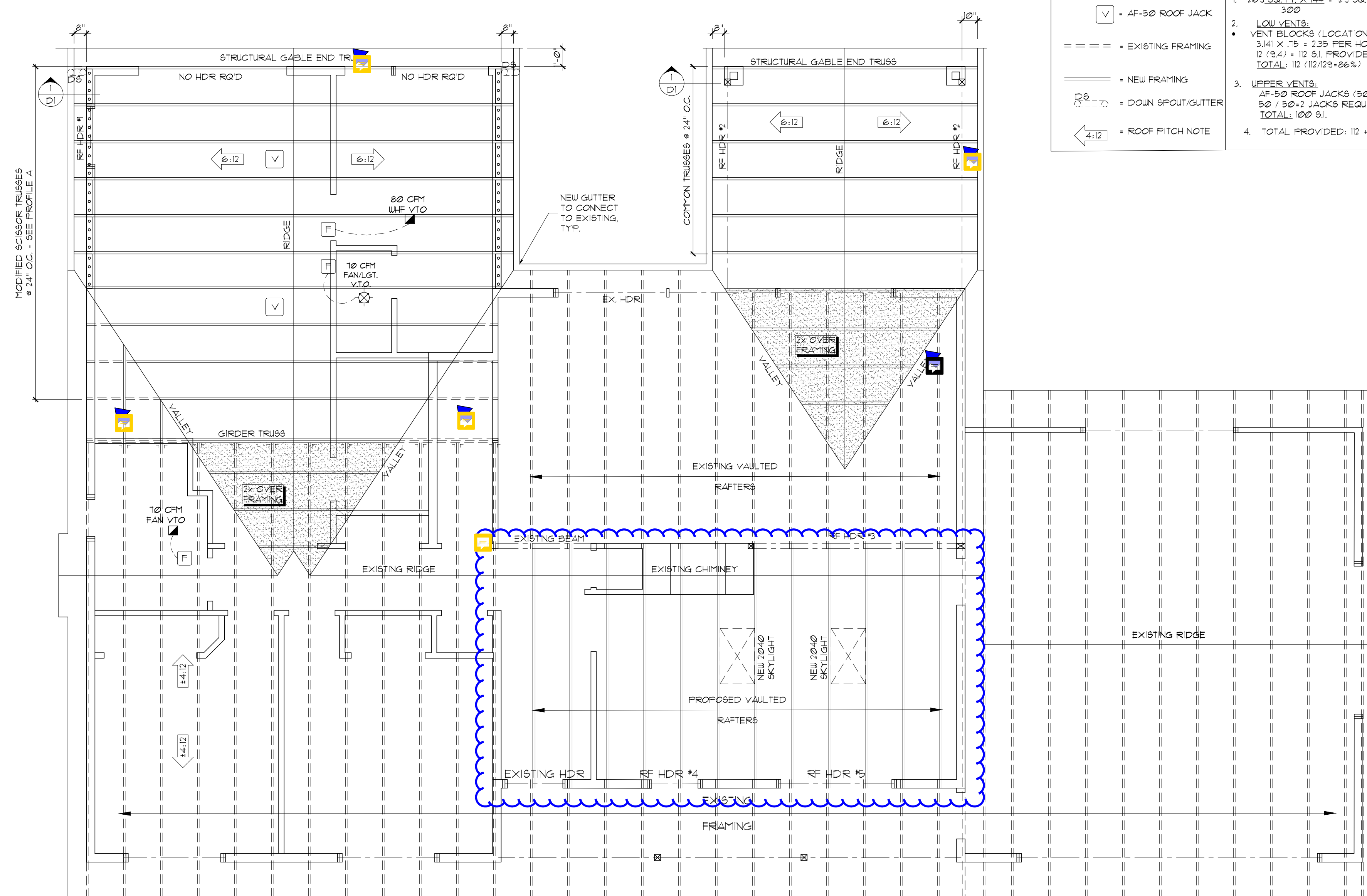
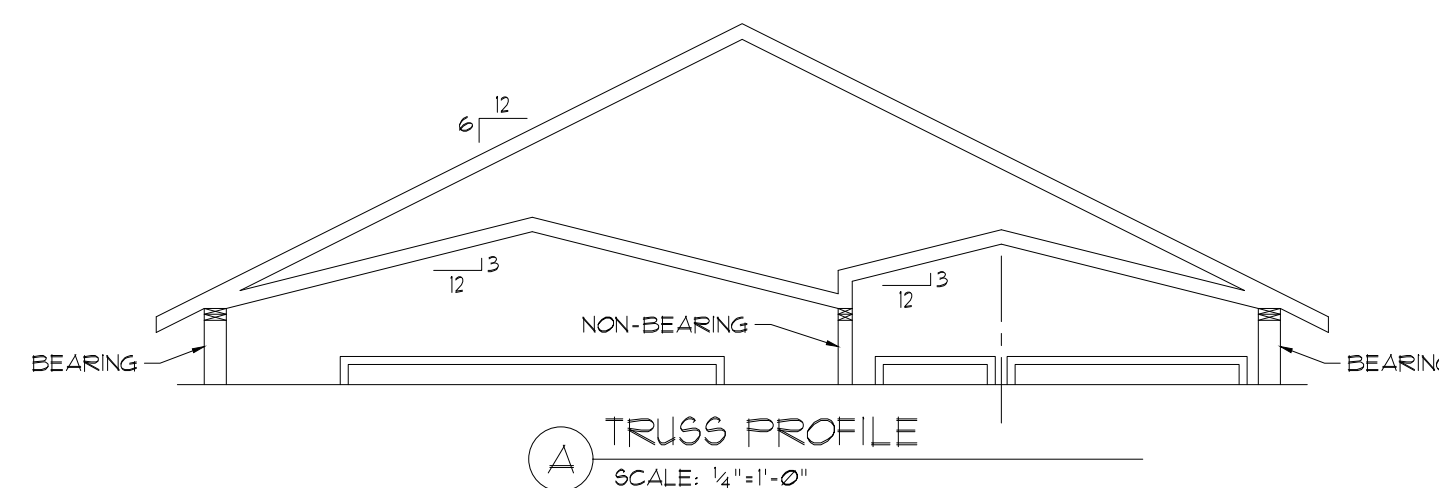
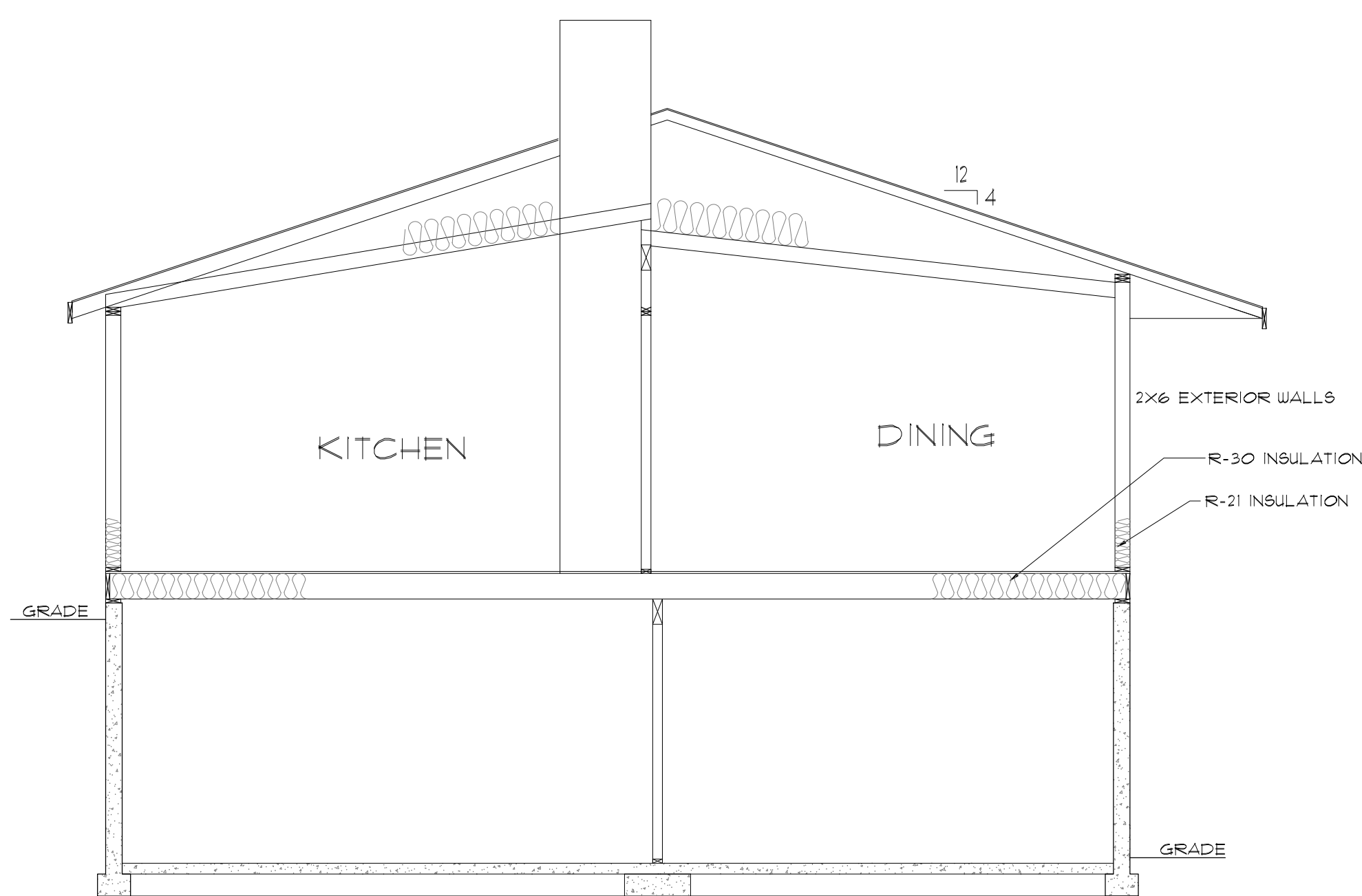

LEGEND	ATTIC VENTILATION
= BIRD BLOCKING	<b>SF. AREA OF TOTAL UPPER ROOF:</b> 1. 269.50 SQ. FT. X 144 = 129.50 IN. REQUIRED 300 2. LOW VENTS: VENT BLOCKS (LOCATIONS NOTED PER PLAN) 3141 X .75 = 235 PER HOLE X4 HOLES = 9.4 SF PER BLOCK 12 (9.4) = 112.81 PROVIDED TOTAL: 112 (112/129 = 86%) 3. UPPER VENTS: AF-50 ROOF JACKS (50 SF EA) 50 / 50 = 1 JACKS REQUIRED TOTAL: 100 SF. 4. TOTAL PROVIDED: 112 + 100 = 212 SF. (212/129 = 16.4%)
= AF-50 ROOF JACK	
= EXISTING FRAMING	
= NEW FRAMING	
= DOWNSPOUT/GUTTER	
= ROOF PITCH NOTE	

**roof framing plan**  
1/4" = 1'-0"

PLAN DATE: ENS. # NAME: DESCRIPTION: ENS. # :

RUIGER  
**Krafting**  
GREG KRUEGER  
206-819-2710  
greg@kruegerkrafting.com

PLAN: QUI REMODEL  
8028 SE 36TH ST.  
MERCER ISLAND, WA 98040  
ROOF FRAMING

FILE NO.  
20-39

SHEET  
A5

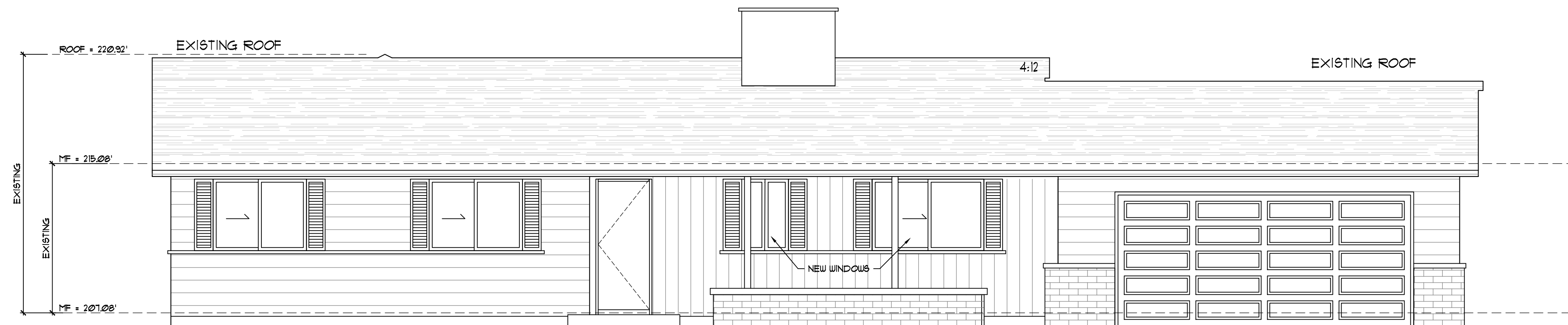

north elevation

1/4" = 1'-0"

AEG = 201.93'

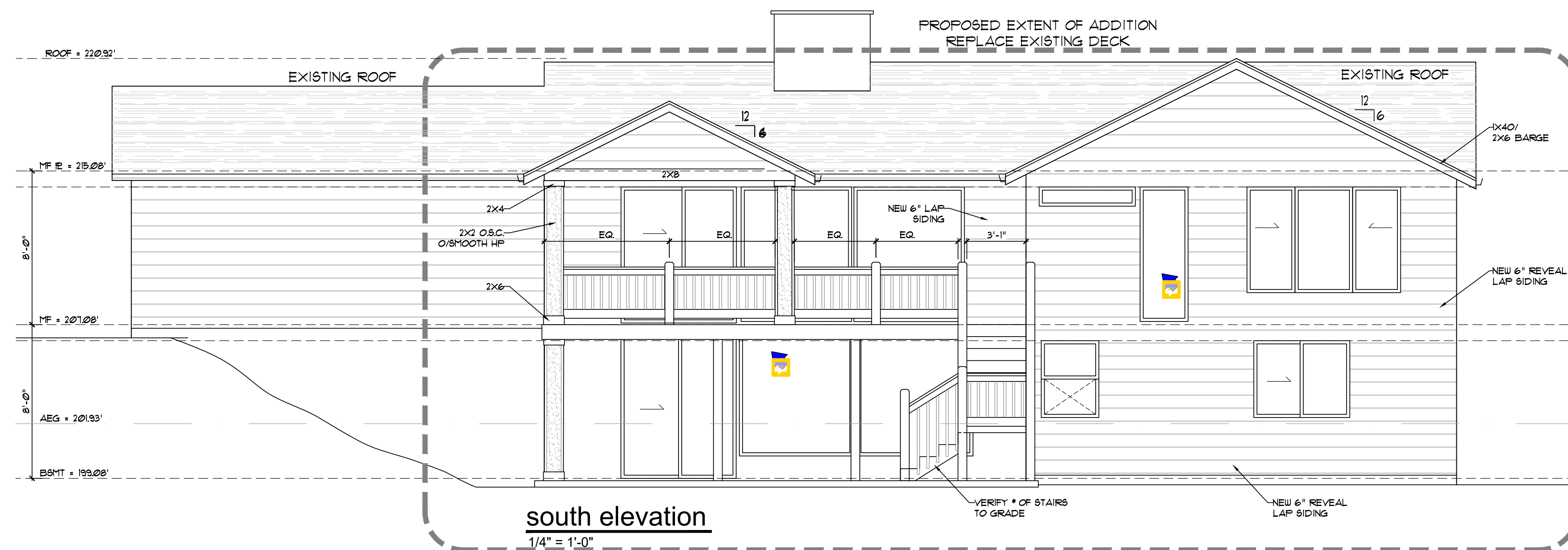

south elevation

1/4" = 1'-0"

AEG = 201.93'

BSMT = 199.08'

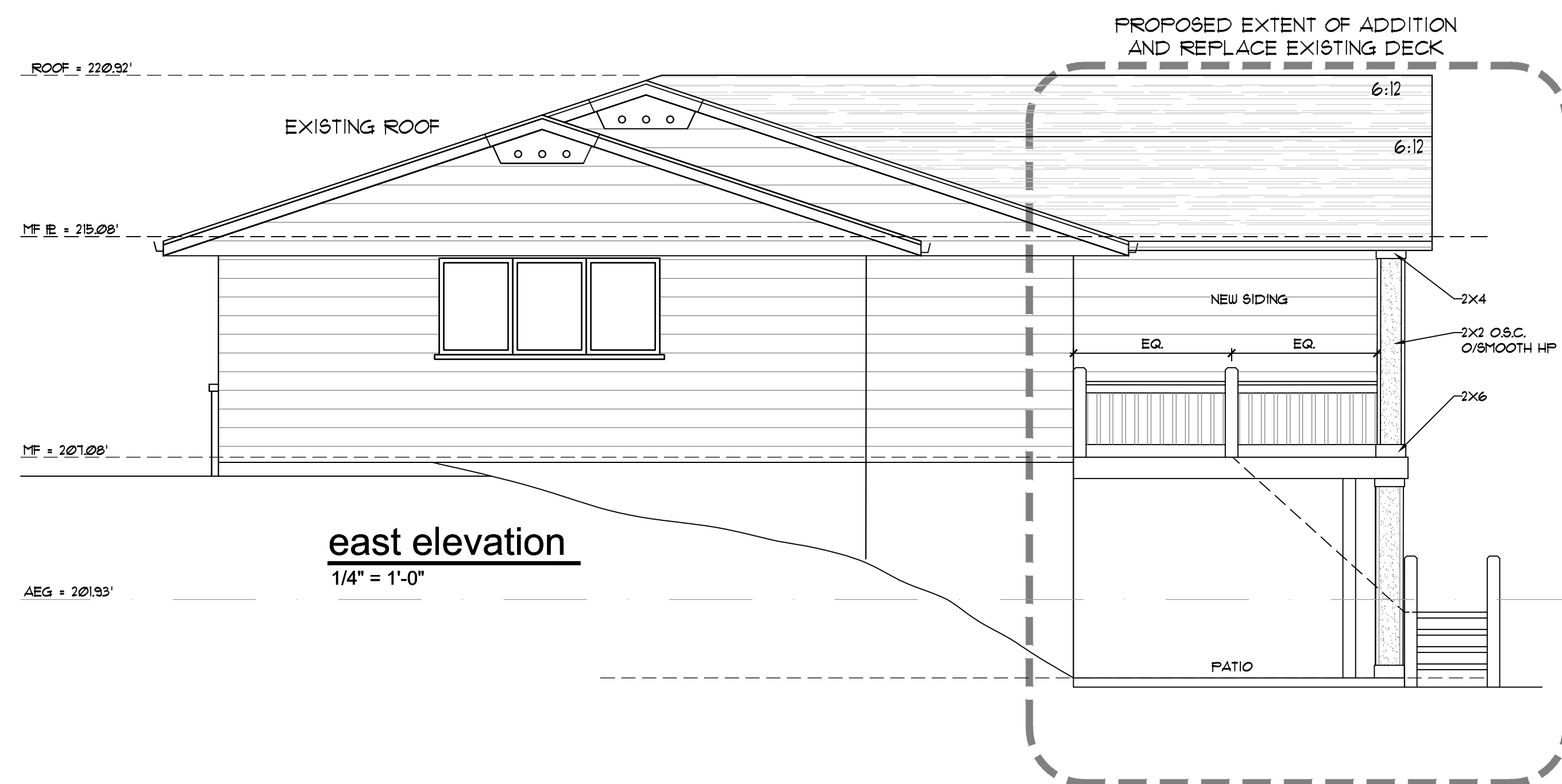

east elevation

1/4" = 1'-0"

AEG = 201.93'

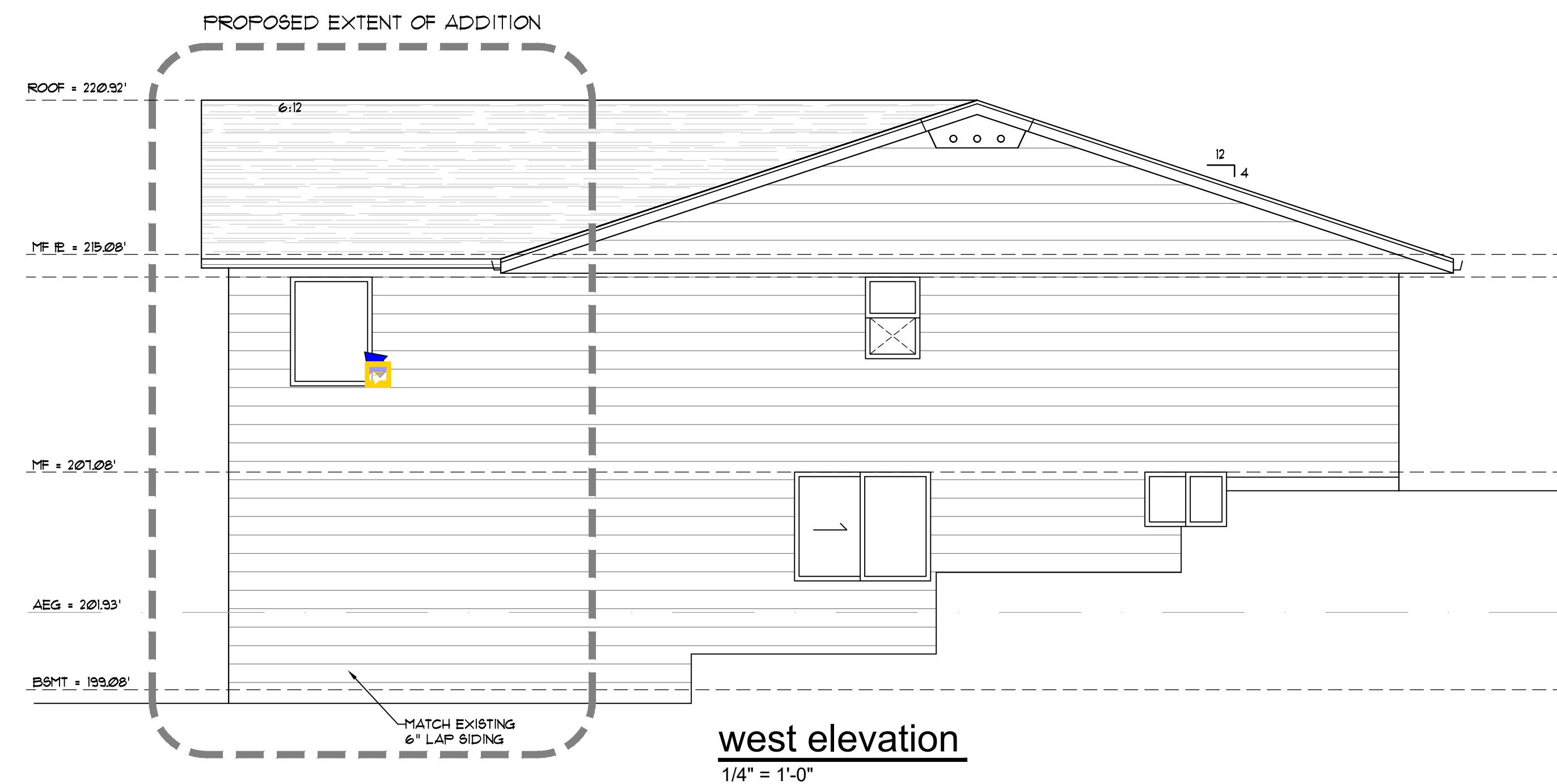

west elevation

1/4" = 1'-0"

AEG = 201.93'

BSMT = 199.08'

PLAN DATE: ENS. # & NAME: DESCRIPTION:

ENS. # :

RUEGER  
**Krafting**  
 GREG KRUEGER  
 206-819-2710  
 greg@kruegerkrafting.com

PLAN: GJ1 REMODEL  
 8028 SE 36TH ST.  
 MERCER ISLAND, WA 98040  
 ELEVATIONS

FILE NO.  
 20-39

SHEET  
 A6

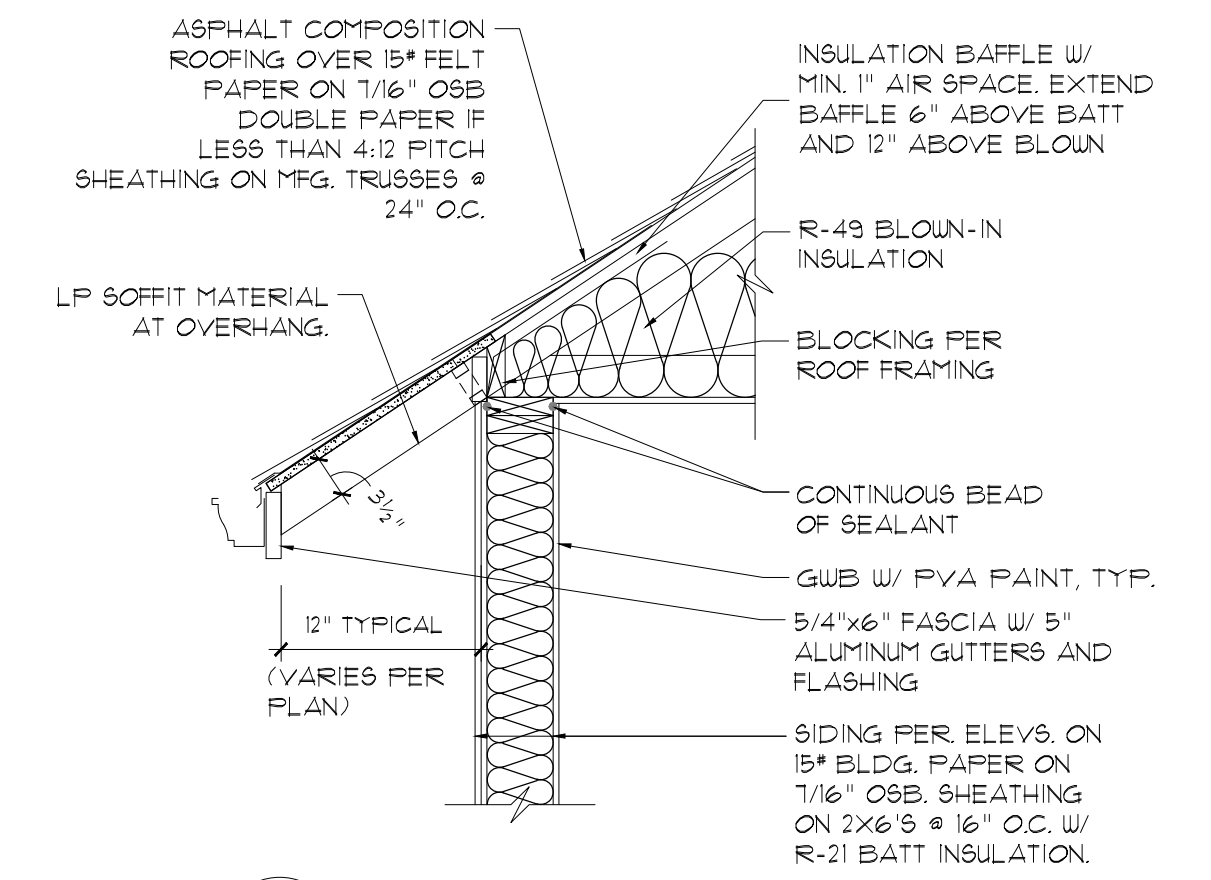

1 TRUSS EAVE  
3/4" = 1'-0"

2 NOT USED  
3/4" = 1'-0"

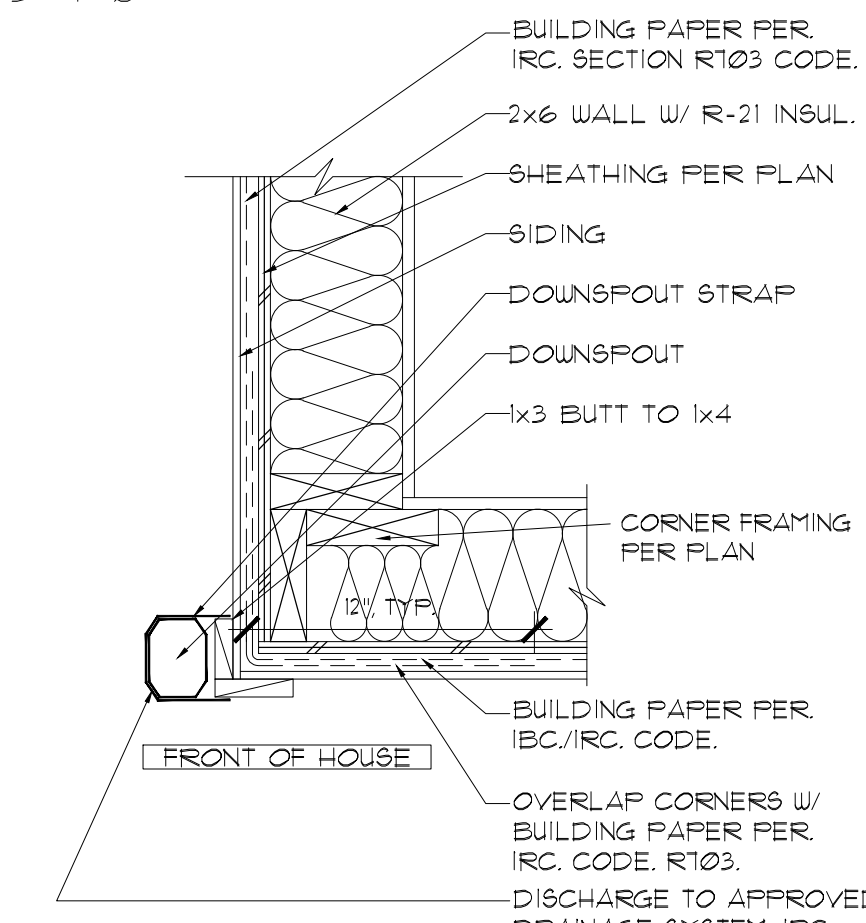

4 DOWNSPOUT DETAIL  
1-1/2" = 1'-0"

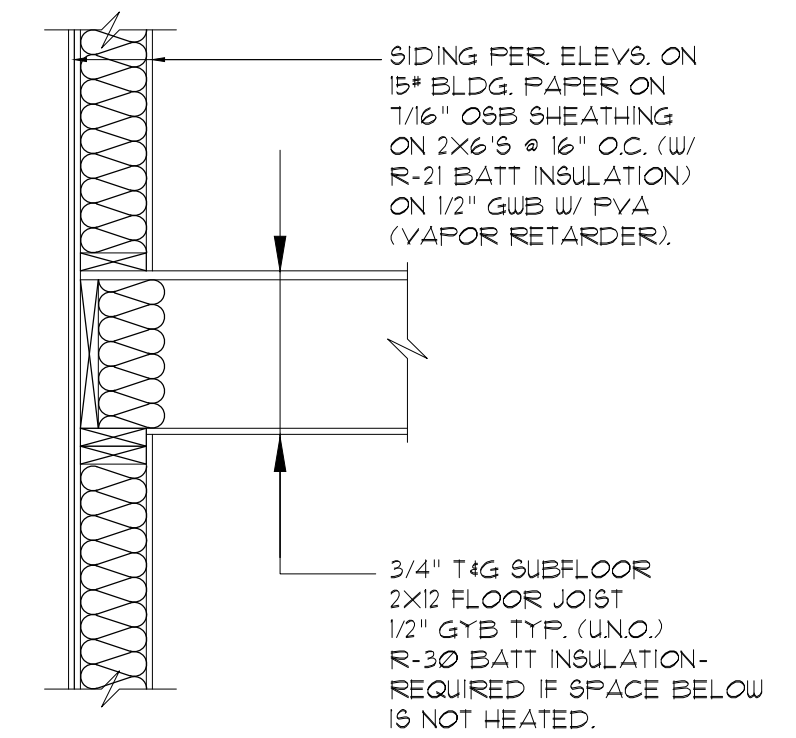

3 FLOOR @ EXTERIOR WALL  
3/4" = 1'-0"

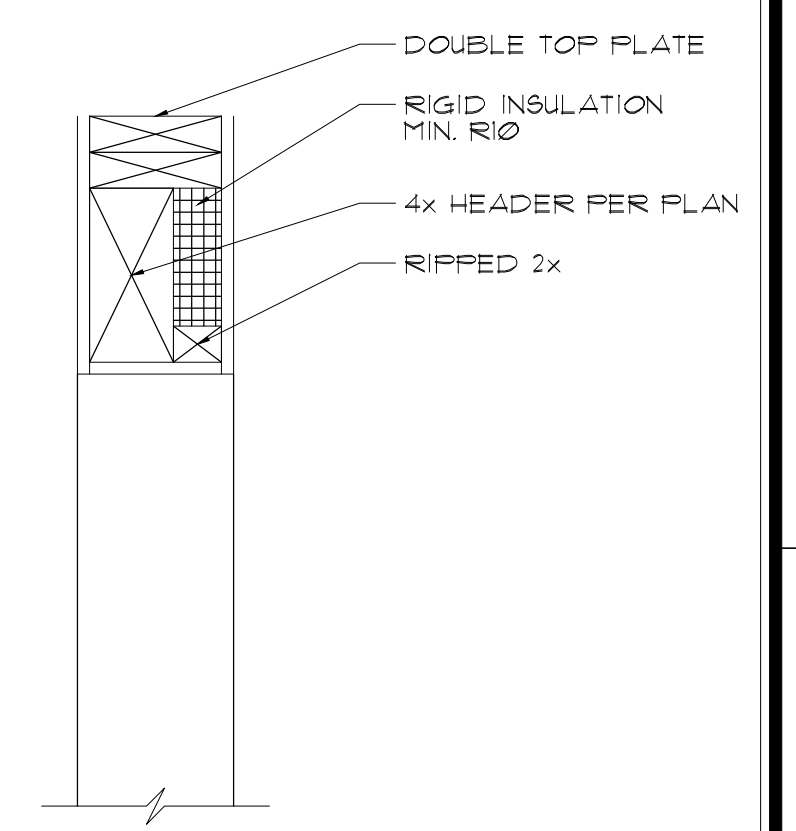

5 TYP. HEADER FRAMING  
3/4" = 1'-0"

6 NOT USED  
3/4" = 1'-0"

DECK DETAILS

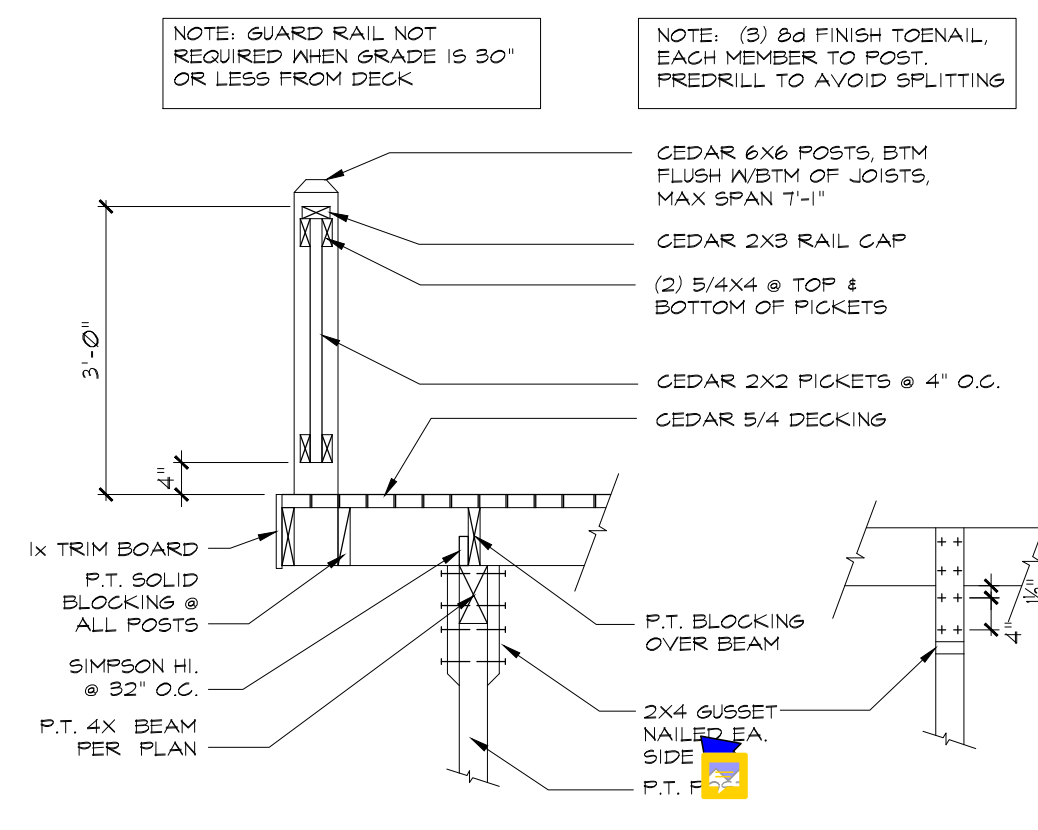

12 GUARDRAIL SECTION  
1/2" = 1'-0"

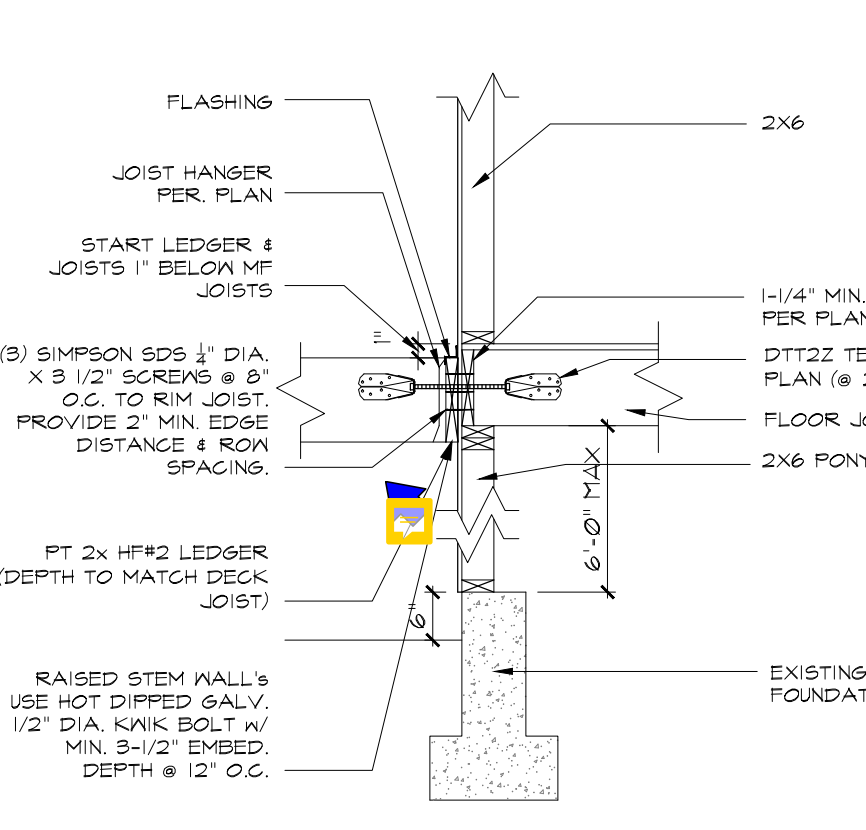

11 LEDGER DETAIL  
1/2" = 1'-0"

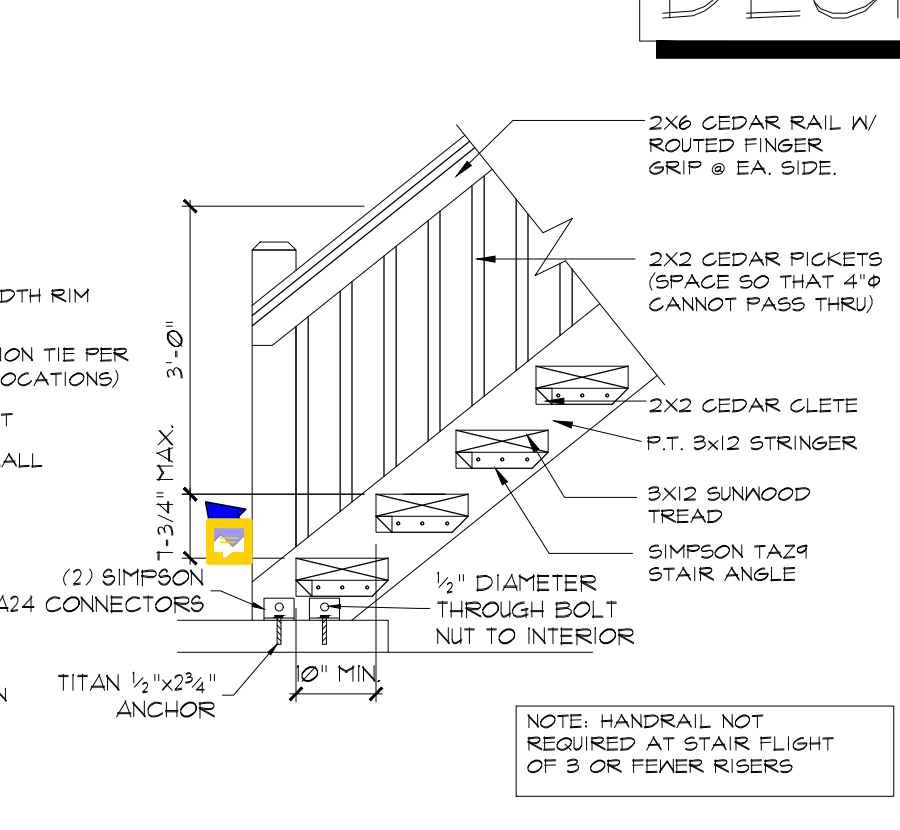

10 STAIR SECTION  
1/2" = 1'-0"

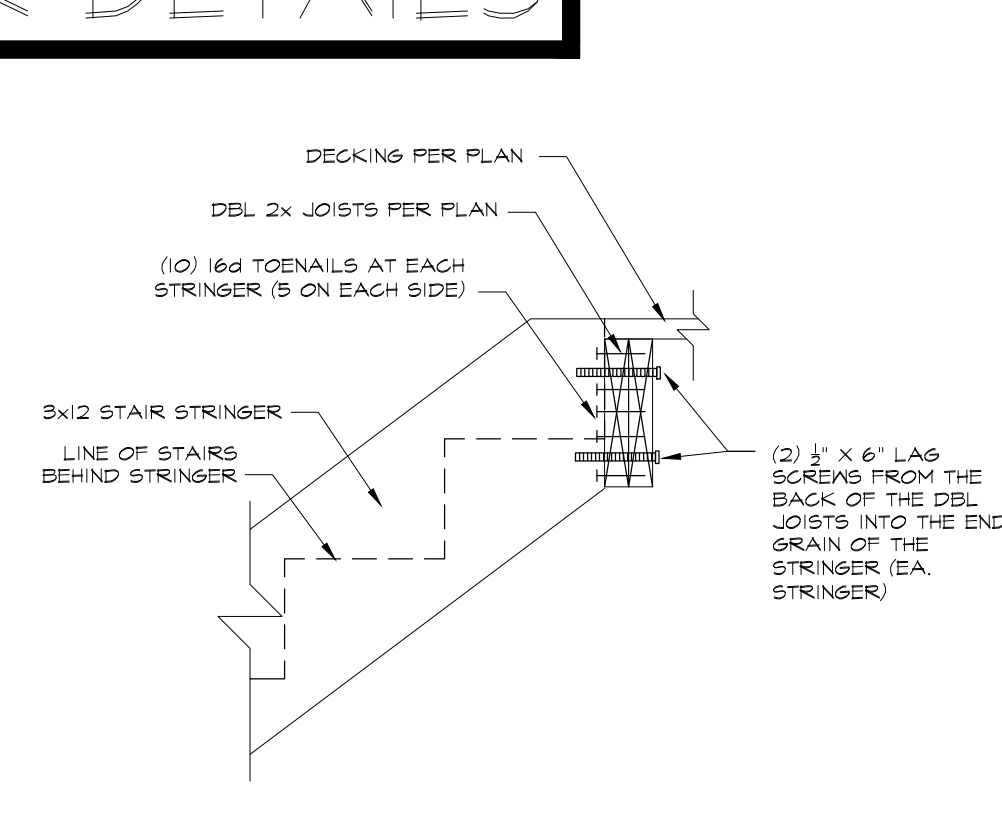

9 STRINGER  
1" = 1'-0"

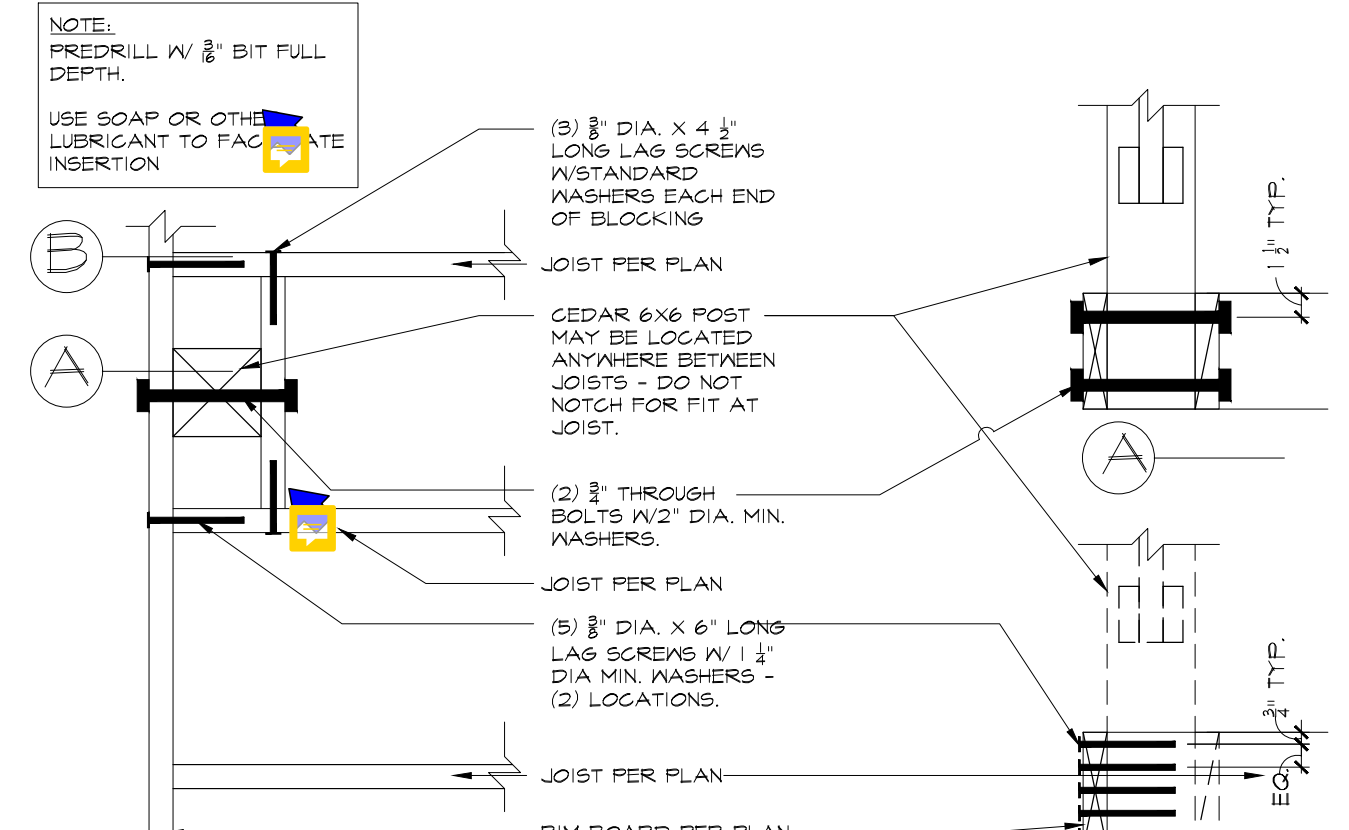

8 PARALLEL POST CONN.  
1" = 1'-0"

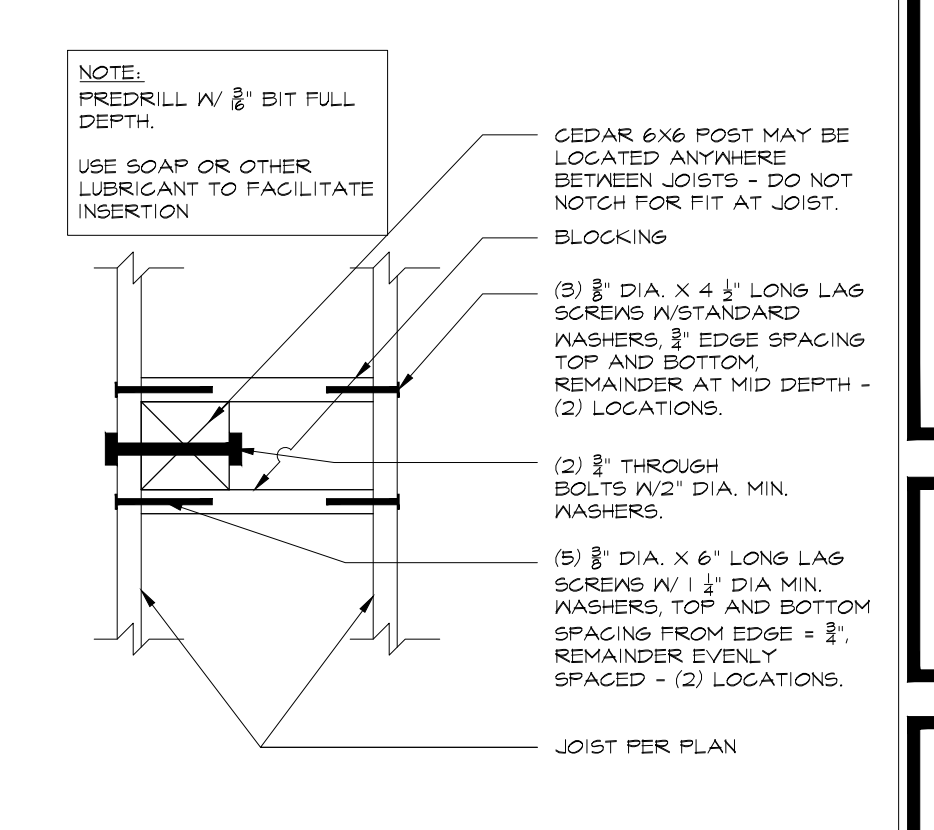

7 PERP. POST CONNECTION  
1" = 1'-0"

PLAN DATE: ENS. # & NAME: DESCRIPTION:

ENS. # :

RUEGER  
**Krafting**  
GREG KRUEGER  
206-819-2710  
greg@kruegerkrafting.com

PLAN: QUI REMODEL  
8028 SE 36TH ST.  
MERCER ISLAND, WA 98040  
DETAILS

FILE NO.  
20-39

SHEET  
D1



### ELECTRICAL SYMBOLS

⊕	SINGLE POLE SWITCH
⊕ <sup>3 OR 4</sup>	THREE OR FOUR -WAY SWITCH
⊕ <sup>D</sup>	DIMMER SWITCH (+48" A.F.F. U.N.O.)
⊕ <sup>⊖</sup>	DEDICATED CIRCUIT
⊕	110 V. OUTLET (+16" A.F.F. U.N.O.)
⊕	110 V. HALF HOT OUTLET (+16" A.F.F. U.N.O.)
⊕ <sup>6FI</sup>	110 V. 6FI DUPLEX OUTLET (+48" A.F.F. U.N.O.)
⊕	220 V. APPLIANCE OUTLET
⊕ <sup>WFO</sup>	WATERPROOF OUTLET
⊕ <sup>SD</sup>	110V SMOKE DETECTOR W/BATTERY BACK-UP
⊕ <sup>CO</sup>	110V CARBON MONOXIDE & SMOKE DETECTOR
⊕ <sup>WFF</sup>	WHOLE HOUSE FAN
⊕ <sup>FL</sup>	EXHAUST FAN/LIGHT COMBINATION 10 CFM U.N.O. - V.T.O.
⊕	TYP. EXHAUST FAN 10 CFM U.N.O. - V.T.O.
⊕	SURFACE MOUNTED LIGHT
⊕	PENDANT MOUNTED LIGHT
⊕	WALL MOUNTED LIGHT
⊕	RECESSED (CAN) LIGHT
⊕ <sup>WFO</sup>	WATERPROOF RECESSED LIGHT
⊕	ELECTRICAL PANEL & METER
⊕	GAS METER

### LOW VOLTAGE SYMBOLS:

⊕	TELEPHONE JACK OPT.
⊕	DATA
⊕	CABLE TV JACK +16" TO TOP (AFF.)
⊕	DOOR BELL CHIME # 8'-0" AFF.

### ELECTRICAL NOTES:

- 1 THERMOSTAT w/ INTERIOR TEMPERATURE GAUGE, 2x8 FLAT-BLOCK AT 54" AFF. FOR THERMOSTAT.
- 2 KITCHEN EXHAUST FANS SHALL HAVE MIN. 100 CFM U.N.O.
- 3 BATH AND UTILITY ROOM EXHAUST FANS TO BE 10 CFM MIN. U.N.O.
- 4 ELECTRICAL CONTRACTOR TO SPECIFY GROUNDING ELECTRODE SYSTEM - BOND TO GAS AND WATER PIPING.
- 5 ALL ELECTRICAL FIXTURES INSTALLED ABOVE TUBS AND SHOWERS TO BE WATERPROOF.
- 6 GFI RECEPTACLES SHALL BE INSTALLED IN KITCHENS AT EACH COUNTER SPACE 12" OR WIDER AND THAT NO POINT ALONG ANY LENGTH OF COUNTER IS MORE THAN 4'-0" FROM ANY OUTLET.
- 7 PROVIDE FLACARD AT CONTROLS TO READ 'WHOLE HOUSE VENTILATION (SEE OPERATING INSTRUCTIONS)'
- 8 PROVIDE DOOR BELL PUSH BUTTON TO THE LEFT OF THE ACTIVE DOOR CENTERED ON THE WALL @ 42" HIGH.
- 9 110V SMOKE DETECTOR INTERCONNECTED W/ BATTERY BACKUP
- 10 WHOLE HOUSE FAN 24-TIMER FRACTIONAL ON TIME TO BE SET BY MECHANICAL CONTRACTOR
- 11 ONE DUPLEX GFI RECEPTACLE EACH SHALL BE PROVIDED AT: FRONT OF DWELLING, REAR OF DWELLING, AND IN GARAGE NEXT TO ELECTRICAL PANEL.

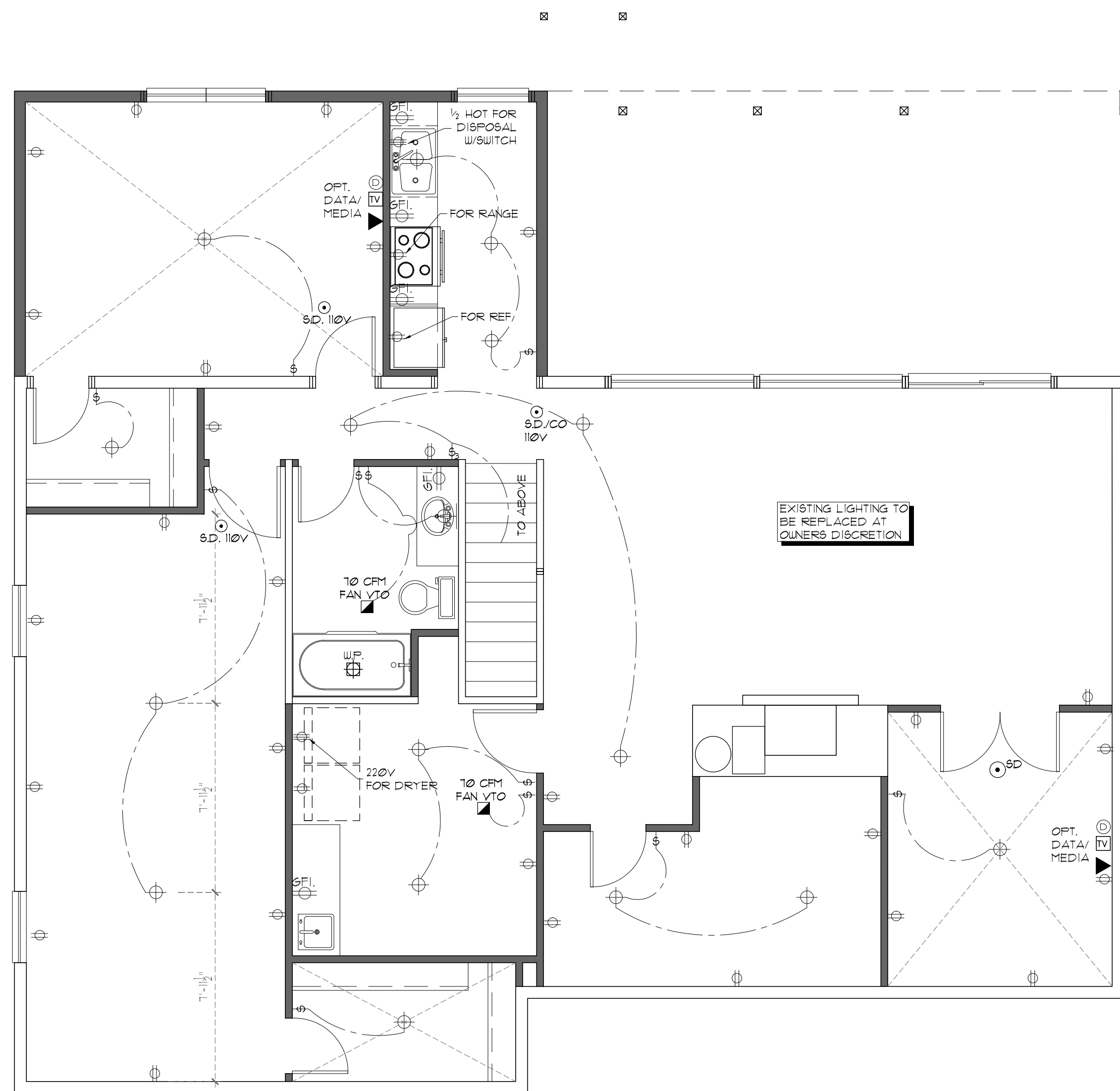

### basement floor electrical

1/4" = 1'-0"

PLAN DATE: ENS. # & NAME: DESCRIPTION:

ENS. # :

RUEGER  
**Krafting**  
 GREG KRUEGER  
 206-819-2710  
 greg@kruegerkrafting.com

PLAN: GVI REMODEL  
 8028 SE 36TH ST.  
 MERCER ISLAND, WA 98040  
 BASEMENT ELECTRICAL PLAN

FILE NO.  
 20-39

SHEET  
 11

ELECTRICAL SYMBOLS	
⊕	SINGLE POLE SWITCH
⊕ <sup>3 OR 4</sup>	THREE OR FOUR -WAY SWITCH
⊕ <sup>D</sup>	DIMMER SWITCH (+48" A.F.F. U.N.O.)
⊕ <sup>DC</sup>	DEDICATED CIRCUIT
⊕ <sup>110</sup>	110 V. OUTLET (+16" A.F.F. U.N.O.)
⊕ <sup>110</sup>	110 V. HALF HOT OUTLET (+16" A.F.F. U.N.O.)
⊕ <sup>60</sup>	110 V. GFI DUPLEX OUTLET (+48" A.F.F. U.N.O.)
⊕ <sup>220</sup>	220 V. APPLIANCE OUTLET
⊕ <sup>WP</sup>	WATERPROOF OUTLET
⊕ <sup>SD</sup>	110V SMOKE DETECTOR W/BATTERY BACK-UP
⊕ <sup>CO</sup>	110V CARBON MONOXIDE & SMOKE DETECTOR
⊕ <sup>WHF</sup>	WHOLE HOUSE FAN
⊕ <sup>FL</sup>	EXHAUST FAN/LIGHT COMBINATION 10 CFM U.N.O. - V.T.O.
⊕	TYP. EXHAUST FAN 10 CFM U.N.O. - V.T.O.
⊕	SURFACE MOUNTED LIGHT
⊕	PENDANT MOUNTED LIGHT
⊕	WALL MOUNTED LIGHT
⊕	RECESSED (CAN) LIGHT
⊕ <sup>WP</sup>	WATERPROOF RECESSED LIGHT
⊕ <sup>M</sup>	ELECTRICAL PANEL & METER
⊕ <sup>G</sup>	GAS METER
LOW VOLTAGE SYMBOLS:	
⊕ <sup>TEL</sup>	TELEPHONE JACK OPT.
⊕ <sup>D</sup>	DATA
⊕ <sup>TV</sup>	CABLE TV JACK 16" TO TOP (AFF.)
⊕ <sup>C</sup>	DOOR BELL CHIME 8'-0" AFF.
ELECTRICAL NOTES:	
1	THERMOSTAT w/ INTERIOR TEMPERATURE GAUGE, 2x8 FLAT-BLOCK AT 54" AFF. FOR THERMOSTAT.
2	KITCHEN EXHAUST FANS SHALL HAVE MIN. 100 CFM U.N.O.
3	BATH AND UTILITY ROOM EXHAUST FANS TO BE 10 CFM MIN. U.N.O.
4	ELECTRICAL CONTRACTOR TO SPECIFY GROUNDING ELECTRODE SYSTEM - BOND TO GAS AND WATER PIPING.
5	ALL ELECTRICAL FIXTURES INSTALLED ABOVE TUBS AND SHOWERS TO BE WATERPROOF.
6	GFI RECEPTACLES SHALL BE INSTALLED IN KITCHENS AT EACH COUNTER SPACE 12" OR UNDER AND THAT NO POINT ALONG ANY LENGTH OF COUNTER IS MORE THAN 4'-0" FROM ANY OUTLET.
7	PROVIDE PLACARD AT CONTROLS TO READ 'WHOLE HOUSE VENTILATION (SEE OPERATING INSTRUCTIONS)'
8	PROVIDE DOOR BELL PUSH BUTTON TO THE LEFT OF THE ACTIVE DOOR CENTERED ON THE WALL @ 42" HIGH.
9	110V SMOKE DETECTOR INTERCONNECTED w/ BATTERY BACKUP
10	WHOLE HOUSE FAN 24-TIMER FRACTIONAL 'ON' TIME TO BE SET BY MECHANICAL CONTRACTOR
11	ONE DUPLEX GFI RECEPTACLE EACH SHALL BE PROVIDED AT: FRONT OF DWELLING, REAR OF DWELLING, AND IN GARAGE NEXT TO ELECTRICAL PANEL.

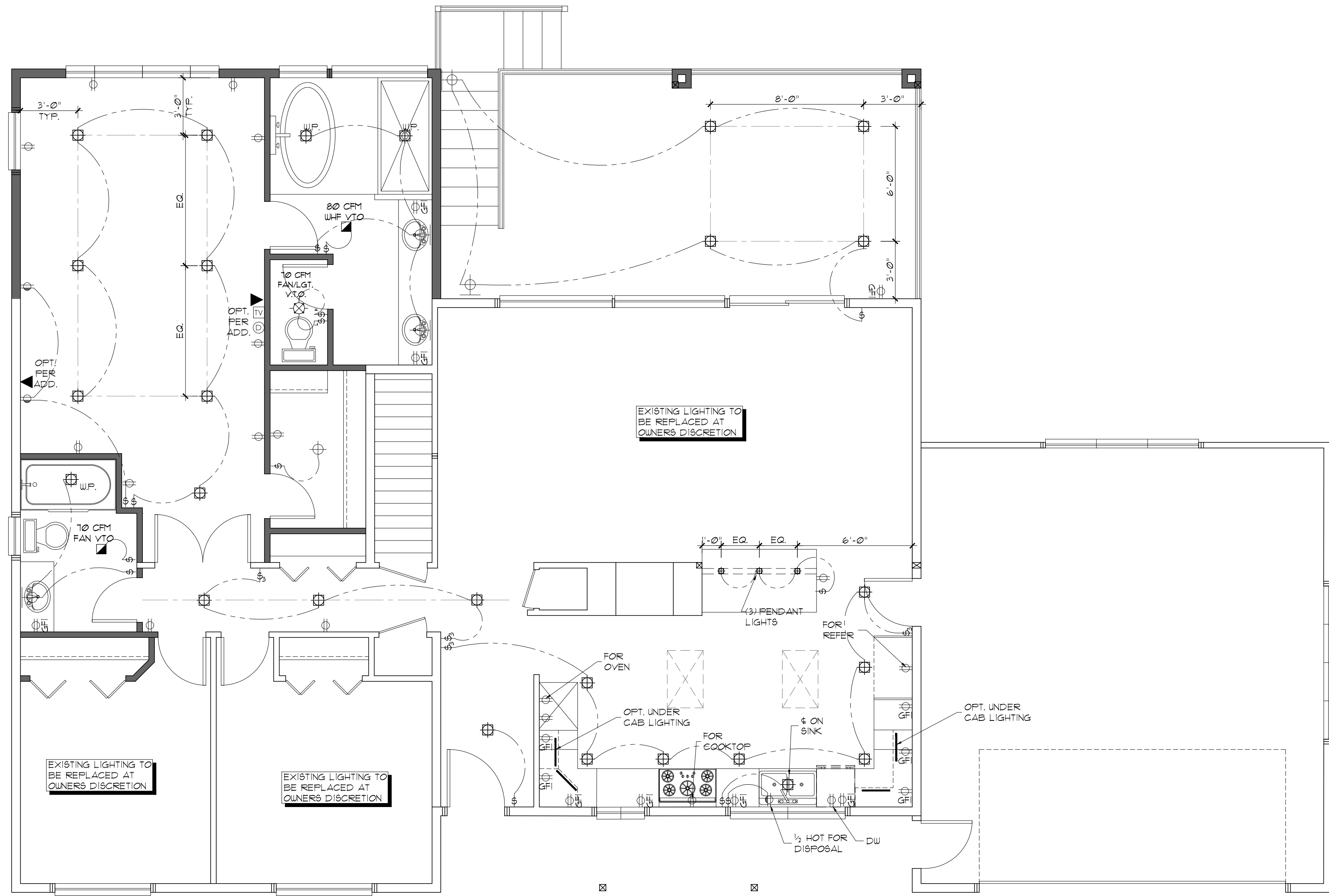

main floor electrical  
1/4" = 1'-0"

PLAN DATE: ENS. # & NAME: DESCRIPTION:  
ENS. # :

PLAN: GVI REMODEL  
8028 SE 36TH ST.  
MERCER ISLAND, WA 98040  
MAIN FLOOR ELECTRICAL PLAN

RUEGER  
**Krafting**  
GREG KRUEGER  
206-819-2710  
greg@kruegerkrafting.com

FILE NO.  
20-39

SHEET  
E2

# QUI RESIDENCE REMODEL - MERCER ISLAND

S200831-6



## PROJECT INFORMATION

### CLIENT

KRUEGER KRAFTING  
GREG KRUEGER, PH: 206-819-2710  
GREG@KRUEGERKRAFTING.COM

### PROJECT ADDRESS

8028 SE 36TH ST  
MERCER ISLAND, WA 98040

### STRUCTURAL ENGINEER

L120 ENGINEERING & DESIGN  
13150 91ST PL NE  
KIRKLAND, WA 98034  
CONTACT: MANS THURFJELL, PE  
PHONE: (425) 636 3313  
EMAIL: MTHURFJELL@L120ENGINEERING.COM

LONGITUDE  
ONE TWENTY  
ENGINEERING & DESIGN

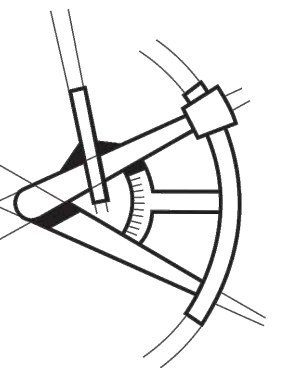

### REVISIONS

DESCRIPTION	DATE	BY
-------------	------	----

## CODES

ENGINEERED PER:  
2015 (SRC) SEATTLE RESIDENTIAL CODE  
2015 (SBC) SEATTLE BUILDING CODE

### PROJECT NAME

QUI RESIDENCE  
REMODEL

8028 SE 36TH ST  
MERCER ISLAND,  
WA 98040

PROJECT NUMBER

S200831-6

DRAWN BY - MRT

CHECKED BY - MRT

SHEET DATE - 9-2-2020

### SCALE

24X36 SHEET: 1/4" = 1'-0"

## SHEET INDEX

STRUCTURAL COVER SHEET...S-0  
STRUCTURAL GENERAL NOTES...S-1  
BASEMENT FLOOR/FOUNDATION PLAN...S-2  
BASEMENT FLOOR WALL FRAMING & SHEAR-WALL PLAN...S-3  
MAIN FLOOR FRAMING PLAN...S-4  
MAIN FLOOR WALL FRAMING & SHEAR-WALL PLAN...S-5  
ROOF FRAMING PLAN...S-6

STRUCTURAL DETAILS...SD-1  
STRUCTURAL DETAILS...SD-2

DESCRIPTION

COVER

SHEET  
S-0



# FOUNDATION NOTES

- GENERAL STRUCTURAL NOTES AND ABBREVIATIONS PER SHEET S-1.
- VERIFY ALL DIMENSIONS AND ELEVATIONS WITH ARCH. PROVIDED DIMENSIONS ARE TO FACE OF CONCRETE STEM WALL OR CENTER OF INDIVIDUAL FOOTING. OUTSIDE FACE OF STEM WALL ALIGNS WITH OUTSIDE FACE OF STUD WALL UNO. STHD HOLD-DOWNS ARE DIMENSIONED TO CENTER OF STRAP. HDU/HD/HTT HOLD-DOWNS ARE DIMENSIONED TO CENTER OF ANCHOR BOLT.
- VERIFY ALL T/CONC ELEVATIONS ON ALL CONCRETE INCLUDING PARTIAL HEIGHT RETAINING WALLS. CONCRETE TO EXTEND MIN 8" ABOVE FINISHED GRADE. PROVIDE 1" RECESS AT DOUBLE SIDED SHEARWALLS TO ACCOMMODATE 3X SILL PLATE.
- FOOTINGS ARE TO BEAR ON COMPETENT NATIVE SOIL OR STRUCTURAL FILL CAPABLE OF SUPPORTING THE ASSUMED BEARING PRESSURE PER GENERAL NOTES. REFERENCE GEOTECHNICAL REPORT (IF AVAILABLE) FOR SUBGRADE PREPARATION, FILL REQUIREMENTS, FOOTING DRAINS, AND OTHER REQUIREMENTS. PROVIDE FOOTING DRAINS AROUND PERIMETER OF BUILDING.
- PRIOR TO POURING CONCRETE CONTRACTOR SHALL LOCATE AND VERIFY LOCATIONS OF ALL FOUNDATION OPENINGS, PENETRATIONS, AND SLOPES.
- ALL WOOD LOCATED WITHIN 8" OF FINISHED GRADE, EXPOSED TO WEATHER OR IN CONTACT WITH CONCRETE SHALL BE PRESSURE TREATED. ALL FASTENERS IN CONTACT WITH FIRE-RETARDANT OR PRESSURE-TREATED WOOD SHALL BE COVERED IN PROTECTIVE COATING (I.E. HDG OR SIM).
- SILL ANCHOR BOLTS (J-BOLTS) SHALL BE ASTM F1554 (36KSI) HDG, ASTM A307 (36KSI) HDG OR SIM. SILL ANCHORS SHALL BE 5/8" DIAM X 8" SIMPSON TITEN HD SCREW ANCHORS OR APPROVED EQUIVALENT. SPACING PER SHEARWALL SCHEDULE (72" O.C. MAX). EACH ANCHOR TO HAVE STANDARD HDG NUT AND WASHER INSTALLED OVER 3"X3"X1/4" HDG PLATE WASHER. EDGE OF PLATE WASHER TO BE LOCATED WITHIN 1/2" OF SHEATHED FACE OF WALL. FOR TWO SIDED SHEARWALLS W/ 2X6 WALL FRAMING, USE 4X4X1/4" PLATE WASHERS OR STAGGER ANCHORS SO THAT EVERY OTHER PLATE WASHER IS LOCATED WITHIN 1/2" OF EACH FACE OF THE WALL.
- HOLD-DOWNS BY SIMPSON STRONG-TIE. INSTALLATION PER MANUFACTURER SPECIFICATIONS. ALTERNATIVE SOLUTIONS SHALL BE SUBMITTED TO EOR FOR APPROVAL PRIOR TO INSTALLATION. HOLD-DOWN THREADED RODS SHALL BE ASTM F1554 (36KSI) HDG UNO. EMBEDDED END OF THREADED ROD TO HAVE 3"X3"X1/4" HDG PLATE WASHER BETWEEN TWO HAND-TIGHTENED HDG STANDARD NUTS.
- CJ INDICATES CONTROL JOINT.
- FIRE-PROOFING AND MOISTURE-PROOFING REQUIREMENTS BY OTHERS.
- EXTERIOR STAIRS AND STEEL-FRAMED STAIRS BY OTHERS.
- TYPICAL DETAILS:
  - 1/SD-1 TYP STEM WALL
  - 2/SD-1 TYP INTERIOR FOOTING
  - 5/SD-1 TYP CORNER BARS REQ'T
  - 7/SD-1 TYP CONSTRUCTION JOINT
  - 8/SD-1 TYP BAR BEND AND HOOK DETAIL

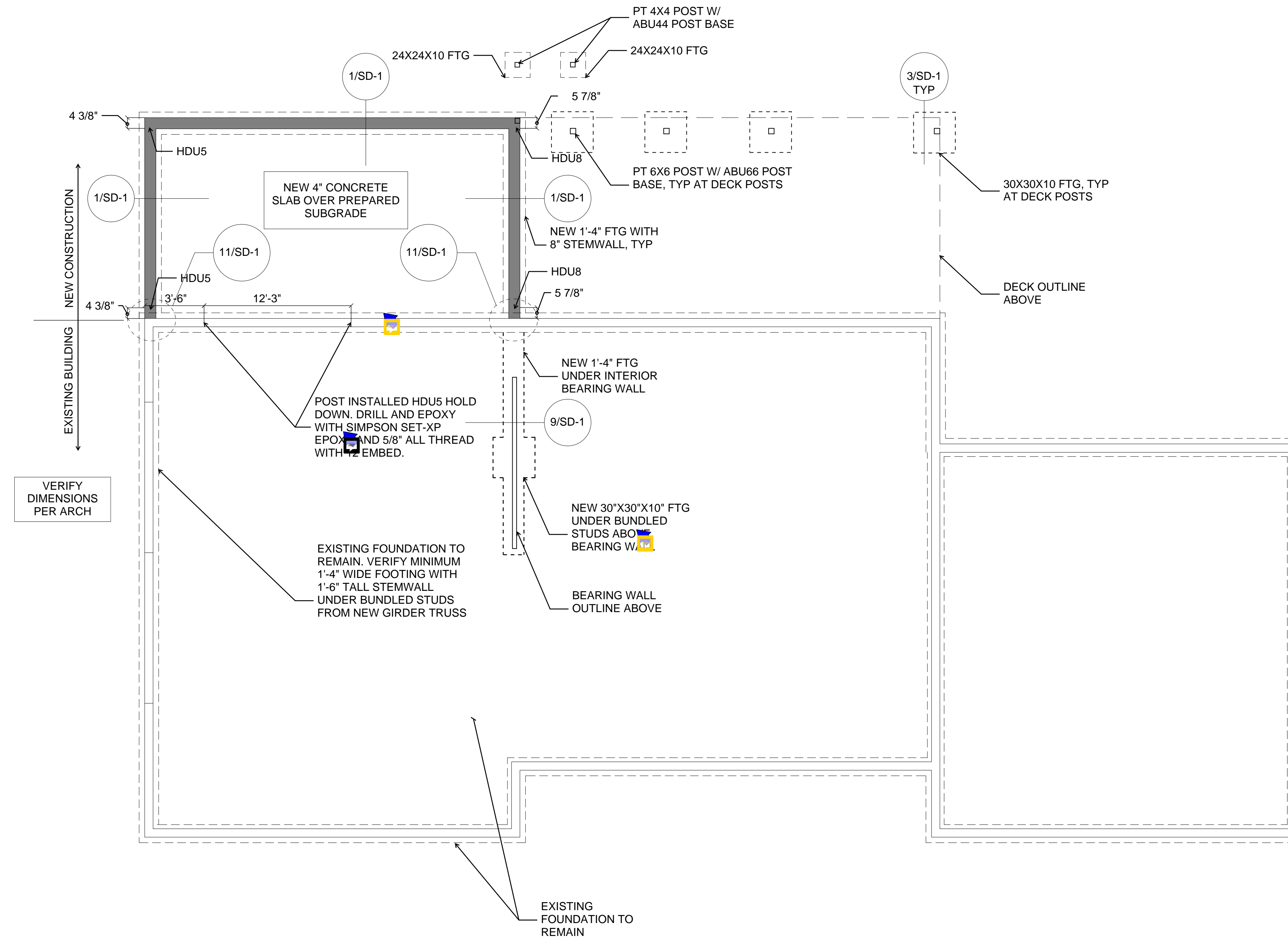

**BASEMENT FLOOR/FOUNDATION PLAN**

HOLD-DOWN SCHEDULE			
MODEL	ANCHOR	EMBEDMENT	MIN END POST
HDU2	5/8" TR	12"	2-2X OR 3X
HDU5	5/8" TR	12"	3-2X
HDU8	7/8" TR	12"	4X6
HDU11	1" TR	12"	PSL 3 1/2 X 51/4

NOTE: ANCHOR RODS TO BE DRILLED AND EPOXIED INTO THE EXISTING CONCRETE FOUNDATION WITH SIMPSON SET-XP. CLEAN, BRUSH, AND BLOW HOLE PRIOR TO INSTALLATION PER SIMPSON INSPECTION AND INSTALLATION GUIDELINES.

### FOUNDATION LEGEND

- INDICATES STEP AT T/FOUNDATION
- INDICATES STEP AT B/FOUNDATION
- TANK WALL (TOP OF WALL NOT TO STEP WITHIN HATCHED REGION)
- HOLD-DOWN BY SIMPSON (STHD/HDU/HD/HTT, TYP)
- FOOTING CENTERED ON POST (L X W X T)



**LONGITUDE**  
ONE TWENTY  
ENGINEERING & DESIGN

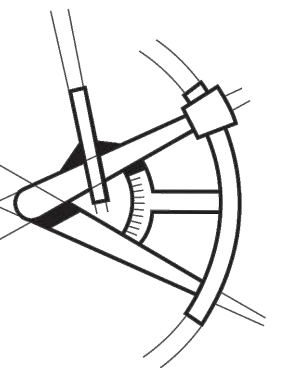

#### REVISIONS

DESCRIPTION	DATE	BY

#### PROJECT NAME

QUI RESIDENCE  
REMODEL

8028 SE 36TH ST  
MERCER ISLAND,  
WA 98040

PROJECT NUMBER

S200831-6

DRAWN BY - MRT

CHECKED BY - MRT

SHEET DATE - 9-2-2020

SCALE

24X36 SHEET: 1/4" = 1'-0"

DESCRIPTION

BASEMENT FLOOR/FOUNDATION PLAN

SHEET S-2

SEE FOUNDATION NOTES IF POST-INSTALLED FOR ANCHOR GUIDELINES/SPECIFICATIONS

SHEAR WALL SCHEDULE

WALL	SHEATHING	PANEL EDGE NAILING (COMMON OR GALV BOX NAILS)	PANEL EDGE STUDS	ANCHOR BOLTS 5/8"Ø EMBED 7"	RIM CONNECTION		
					AT MUD SILL/ PLATE	AT ROOF EAVE TOP PLATE	AT SILL PLATE (SINKER NAIL .148Ø x 3 1/4")
SW6	7/16" APA PLY ONE SIDE	8d AT 6" O.C.	2x	48" O.C. IN 2x PLATE	LTP4 AT 24" O.C.	RBC AT 16" O.C.	16d AT 6" O.C.
SW4	7/16" APA PLY ONE SIDE	8d AT 4" O.C.	2x	32" O.C. IN 2x PLATE	LTP4 AT 16" O.C.	RBC AT 12" O.C.	16d AT 4" O.C.
SW3	7/16" APA PLY ONE SIDE	8d AT 3" O.C.	3x	16" O.C. IN 2x PLATE	LTP4 AT 16" O.C.	RBC AT 8" O.C.	16d AT 3" O.C.
SW2	7/16" APA PLY ONE SIDE	8d AT 2" O.C.	3x	12" O.C. IN 2x PLATE	LTP4 AT 12" O.C.	RBC AT 8" O.C.	16d AT 2" O.C.
2W4	7/16" APA PLY TWO SIDES	8d AT 4" O.C. EA SIDE	3x	24" O.C. IN 3x PLATE	LTP4+A35 @ 16" O.C. EA SIDE	N.A. AT ROOF EAVE	(2) ROWS 16d AT 4" O.C.
2W3	7/16" APA PLY TWO SIDES	8d AT 3" O.C. EA SIDE	3x	16" O.C. IN 3x PLATE	LTP4+A35 @ 16" O.C. EA SIDE	N.A. AT ROOF EAVE	(2) ROWS 16d AT 3" O.C.
2W2	7/16" APA PLY TWO SIDES	8d AT 2" O.C. EA SIDE	3x	16" O.C. IN 3x PLATE	LTP4+A35 @ 12" O.C. EA SIDE	N.A. AT ROOF EAVE	(2) ROWS 16d AT 2" O.C.

NOTES: 1) FOR NON-SHEAR WALL, PROVIDE ANCHOR BOLTS @ 72" O.C.

WALL FRAMING AND SHEAR  
WALL NOTES

- GENERAL STRUCTURAL NOTES AND ABBREVIATIONS PER SHEET S-1.
- VERIFY ALL DIMENSIONS AND ELEVATIONS WITH ARCH.
- LUMBER GRADE PER GENERAL STRUCTURAL NOTES.
- ALL BUNDLED STUDS SPECIFIED PER PLAN SHALL BE CONNECTED TOGETHER WITH 16d @ 6" O.C.
- EXTERIOR WALL STUDS SHALL BE 2X6 @ 16" O.C. ( $\leq 10'$ ), 2X6 @ 12" O.C. ( $> 10'$ ) UNO. INTERIOR WALL STUDS SHALL BE 2X4 @ 16" O.C. UNO. ALL INTERIOR NON-BEARING WALLS TO BE FRAMED MIN 0.25" UNDER FLOOR SYSTEM.
- PROVIDE ONE KING STUD AND ONE JACK STUD MINIMUM AT EVERY HEADER UNO. JACK STUDS SHOULD BE CONTINUOUS TO THE FOUNDATION AND SHALL HAVE VERTICAL CRUSH BLOCKING WITHIN THE FLOOR FRAMING DEPTH MATCHING THE WIDTH OF JACK STUDS.
- SHEARWALL SHEATHING AND NAILING REQUIREMENTS PER SHEARWALL SCHEDULE. ALL EXTERIOR WALLS SHALL BE TYPE SW6 UNO.
- ALL SHEATHING PANEL EDGES TO OCCUR OVER STUDS, PLATES, RIMS OR HORIZONTAL BLOCKING. PANEL EDGE NAILING PER SHEARWALL SCHEDULE, FIELD NAILING AT 12" O.C. UNO.
- PROVIDE MIN TWO 2X STUDS AT EACH END OF SHEARWALL UNO. PROVIDE PANEL EDGE NAILING INTO EACH STUD AT END OF WALL.
- SHEARWALL PANEL EDGE STUDS INDICATE THE MINIMUM STUD WIDTH AT ABUTTING PANEL EDGES. TWO 2X STUDS ARE AN ACCEPTABLE ALTERNATE FOR 3X STUDS. TWO 2X STUDS ARE TO BE NAILED TOGETHER WITH TWO ROWS 10d NAILS AT 6" O.C (4" O.C. @ SW2 AND 2W2). AT DOUBLE SIDED SHEARWALLS VERTICAL PANEL EDGES TO BE STAGGERED ON OPPOSITE SIDES OF THE WALL EXCEPT END OF SHEARWALL.
- LTP4 INSTALLED OVER PLYWOOD SHALL USE 8d COMMON NAILS (.131Ø X 2.5") LTP4 INSTALLED DIRECTLY AGAINST FRAMING MAY USE 8d SHORT (.131X 1.5") RBC INSTALLED DIRECTLY AGAINST FRAMING USE 10d SHORT (.148X 1.5").
- WINDOW STRAP INDICATES THAT A WINDOW IS INCORPORATED WITHIN THE SHEAR WALL. REFER TO FORCE-TURNER AROUND OPENING DETAIL FOR FRAMING REQUIREMENTS.
- STHD HOLD-DOWNS ARE DIMENSIONED TO CENTER OF STRAP. HDU/HD HOLD-DOWNS ARE DIMENSIONED TO CENTER OF ANCHOR BOLT.
- SILL ANCHOR BOLTS (J-BOLTS) SHALL BE ASTM F1554 (36KSI) HDG, ASTM A307 (36KSI) HDG OR SIM. ANCHOR BOLTS TO BE 5/8"Ø X 7" MIN EMBEDMENT. SPACING PER SHEARWALL SCHEDULE (72" O.C. MAX). EACH ANCHOR BOLT TO HAVE STANDARD HDG NUT AND WASHER INSTALLED OVER 3"X3"X1/4" HDG PLATE WASHER WITH AND EDGE OF THE PLATE WASHER LOCATED WITHIN 1/2" OF SHEATHED FACE OF WALL. FOR TWO-SIDED SHEARWALLS W/ 2X6 WALL FRAMING USE 4X4X1/4" PLATE WASHERS OR STAGGER ANCHOR BOLTS SO THAT EVERY OTHER PLATE WASHER IS LOCATED WITHIN 1/2" OF EACH FACE OF THE WALL.
- ALL HANGERS TO BE MANUFACTURED BY SIMPSON STRONG-TIE. INSTALLATION PER MANUFACTURER'S RECOMMENDATIONS. ALTERNATIVE SOLUTIONS SHALL BE SUBMITTED TO EOR FOR APPROVAL PRIOR TO INSTALLATION. REFER TO TYPICAL HANGER SCHEDULE FOR HANGER SIZE UNO ON PLAN OR DETAILS.
- FIRE-PROOFING AND MOISTURE-PROOFING REQUIREMENTS BY OTHERS.



LONGITUDE  
ONE TWENTY  
ENGINEERING & DESIGN

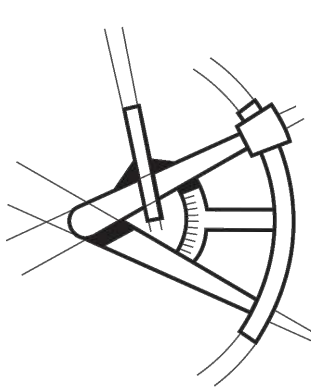

REVISIONS

DESCRIPTION	DATE	BY

PROJECT NAME

QUI RESIDENCE  
REMODEL

8028 SE 36TH ST  
MERCER ISLAND,  
WA 98040

PROJECT NUMBER

S200831-6

DRAWN BY -

MRT

CHECKED BY -

MRT

SHEET DATE -

9-2-2020

SCALE

24X36 SHEET: 1/4" = 1'-0"

DESCRIPTION  
BASEMENT FLOOR WALL FRAMING  
PLAN & SHEAR-WALL PLAN  
SHEET  
S-3

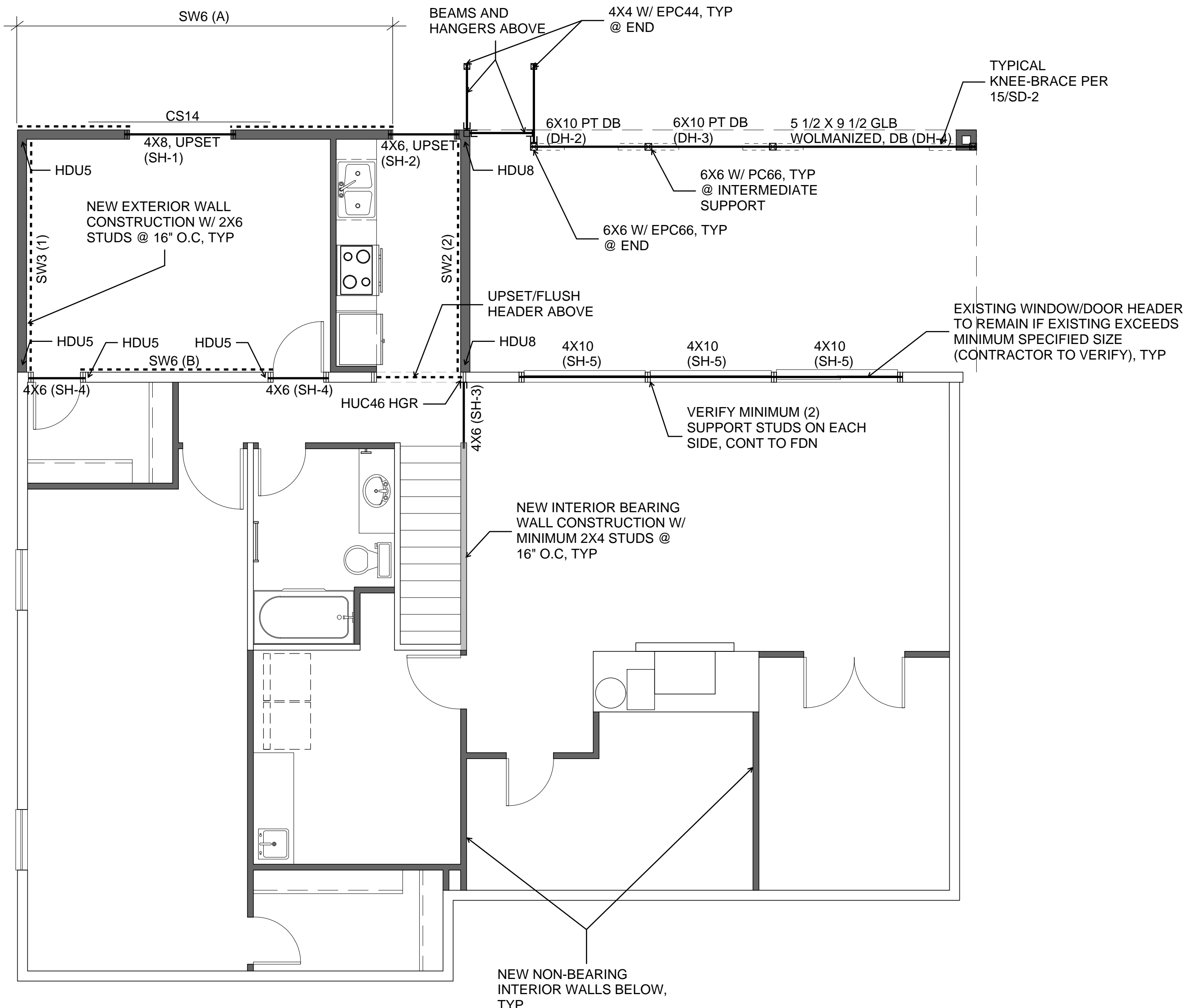

FRAMING AND SHEATHING LEGEND

- HOLD-DOWN BY SIMPSON (STHD/MST/HDU/HO, TYP)
- INDICATES THE NUMBER OF KING AND JACK STUDS
- INDICATES SHEARWALL LOCATION (SW# - SHEAR WALL MARK)
- HORIZONTAL STRAP (EXAMPLE)
- HEADER
- SHEAR WALL CALLOUT
- REFERENCE TO WALL DESIGNATION IN THE CALCULATION PACKAGE
- REFERENCE TO SHEAR WALL TYPE PER SHEAR WALL SCHEDULE
- 
- REFERENCE TO BEAM OR TRUSS CALCULATION IN CALCULATION PACKAGE
- BEAM OR TRUSS MEMBER

BASEMENT FLOOR WALL FRAMING & SHEAR-WALL PLAN

# FLOOR FRAMING NOTES

- GENERAL STRUCTURAL NOTES AND ABBREVIATIONS PER SHEET S-1.
- VERIFY ALL DIMENSIONS AND ELEVATIONS WITH ARCH.
- FLOOR SHEATHING PER GENERAL NOTES. ALL SHEATHING TO BE GLUED AND NAILED TO FRAMING PER MANUFACTURER RECOMMENDATIONS. USE 8d COMMON NAILS (0.131" X 2 1/2") @ 6" O.C. AT PANEL EDGES AND AT ALL FRAMING DESIGNATED "WITH EDGE NAILING" OR "W/EN", AND 12" O.C. IN THE FIELD. UNO. PANEL EDGE JOINTS TO BE STAGGERED BETWEEN ADJACENT PANELS OF SHEATHING. PROVIDE GAP BETWEEN PANELS TO ALLOW FOR NATURAL EXPANSION/CONTRACTION (1/8" GAP TYP).
- LOCATE ALL OPENINGS AND PENETRATIONS AND VERIFY NO CONFLICT WITH FLOOR FRAMING. MECHANICAL, ELECTRICAL, AND PLUMBING DRAWINGS BY OTHERS.
- ALL WOOD LOCATED WITHIN 8" OF FINISHED GRADE, EXPOSED TO WEATHER OR IN CONTACT WITH CONCRETE SHALL BE PRESSURE TREATED. ALL FASTENERS IN CONTACT WITH FIRE-RETARDANT OR PRESSURE-TREATED WOOD SHALL BE COVERED IN PROTECTIVE COATING (I.E. HDG OR SIM).
- ALL BEAMS SHALL BE SUPPORTED BY MIN TWO STUDS BELOW EACH END, UNLESS NOTED OTHERWISE ON PLAN. ALL BEAMS SHALL BE FRAMED FLUSH WITH JOISTS UNO. "DROPPED BEAM" OR "DB" INDICATES T/B/EAM EQUAL B/JOISTS. "TOP FLUSH" OR "TF" INDICATES T/B/EAM EQUAL T/JOISTS AND B/BEAM EXTENDING BELOW B/JOISTS. "BOTTOM FLUSH" OR "BF" INDICATES B/BEAM EQUAL B/JOISTS AND T/B/EAM EXTENDING ABOVE T/JOISTS.
- ALL NON-BEARING WALLS TO BE FRAMED MIN 0.25" UNDER FLOOR SYSTEM.
- STUD QUANTITIES, POST SIZE, HOLDOWN, AND SHEARWALL REQUIREMENTS PER WALL FRAMING AND SHEARWALL PLAN BELOW.
- ALL POSTS ABOVE THE FLOOR FRAMING SHALL BE BLOCKED WITHIN THE FLOOR DEPTH ("VERTICAL GRAIN BLKG", "VERTICAL CRUSH BLKG", OR "VCB"). BLOCKING WIDTH SHALL MATCH WIDTH OF POST OR BUNDLED STUDS ABOVE AND EXTEND FULL FLOOR DEPTH.
- HORIZONTAL STRAPS INDICATED ON FRAMING PLANS SHALL BE CENTERED OVER THE TOP PLATE, BEAM, OR BLOCKING. STRAP LENGTH PER PLAN.
- ALL TIES AND HANGERS TO BE MANUFACTURED BY SIMPSON STRONG-TIE. INSTALLATION PER MANUFACTURER'S RECOMMENDATIONS. ALTERNATIVE SOLUTIONS SHALL BE SUBMITTED TO EOR FOR APPROVAL PRIOR TO INSTALLATION. REFER TO TYPICAL HANGER SCHEDULE FOR HANGER SIZE UNO ON PLAN OR DETAILS.
- ENGINEERED FLOOR JOISTS AND FLOOR TRUSSES TO BE DESIGNED BY OTHERS. REFER TO STRUCTURAL GENERAL NOTES FOR SUBMITTAL INFORMATION, AND DESIGN CRITERIA.
- FIRE-PROOFING AND MOISTURE-PROOFING REQUIREMENTS BY OTHERS.

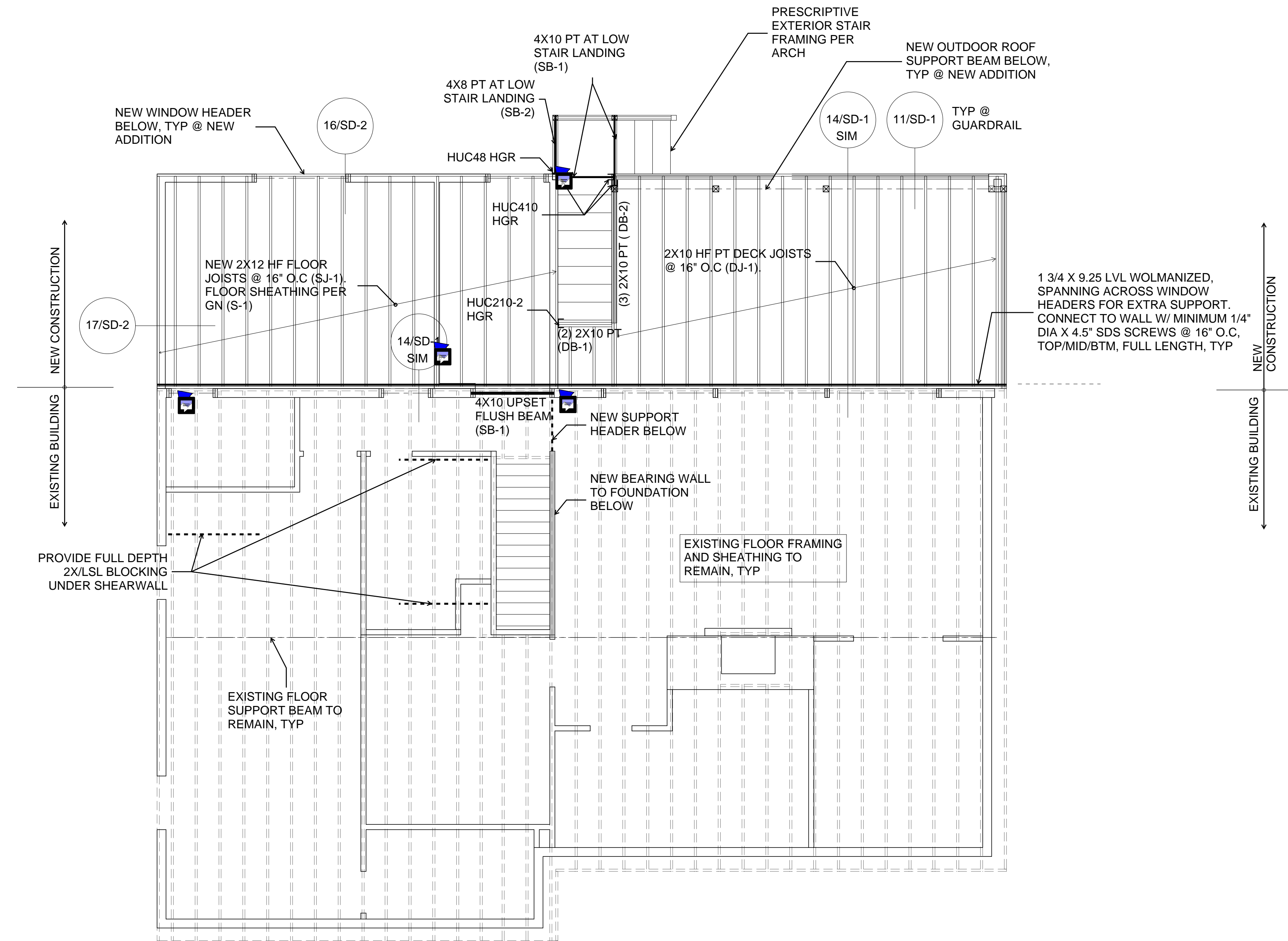

## FRAMING LEGEND

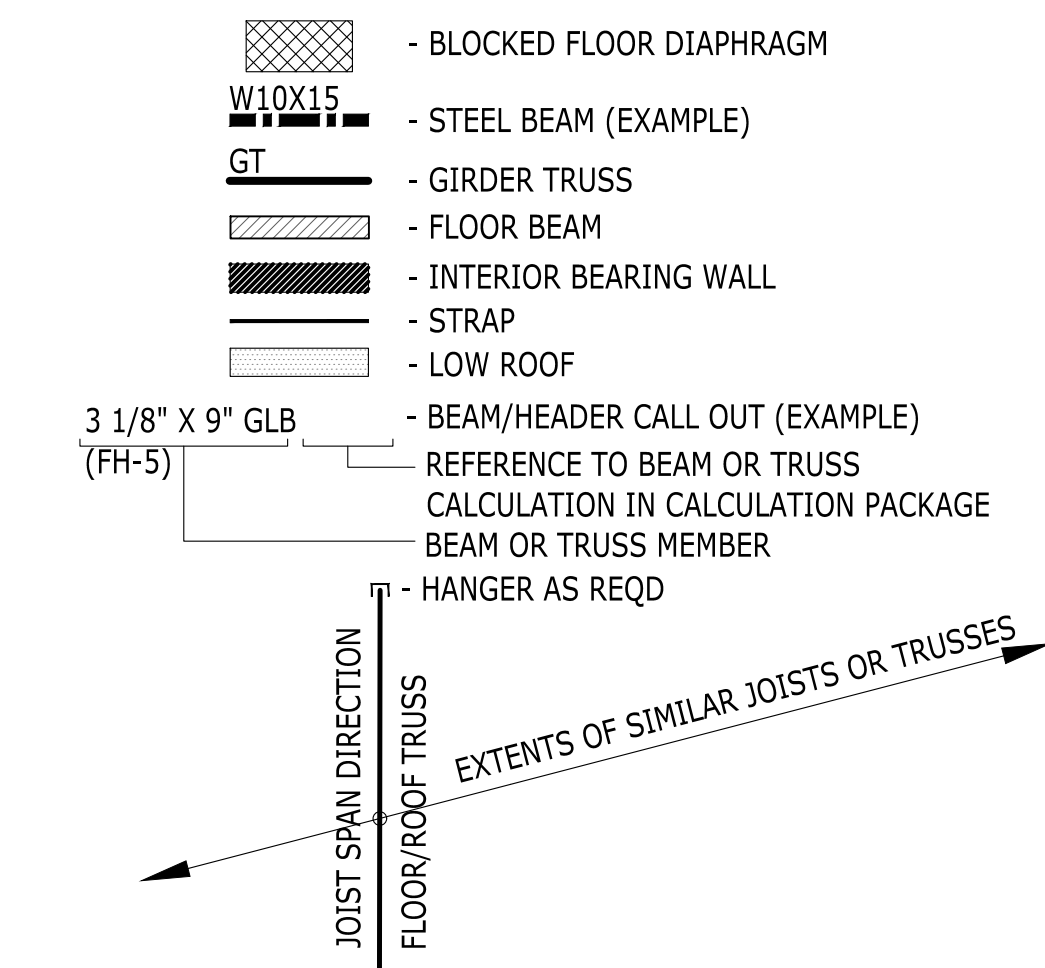

TYPICAL JOIST HANGER SCHEDULE			
TJ1210			
11 7/8"	2-PLY 11 7/8"	14"	2-PLY 14"
IUS2.06/11.88	MIU4.28/11	IUS2.06/14	MIU4.28/14
2X8 OR 2X10 (UNO PER PLAN W/ INDIVIDUAL HANGERS)			
1-PLY		2-PLY	
LUS210		LUS210-2	

TYPICAL BEAM HANGER SCHEDULE				
LVL / LSL / PSL				
	1 3/4"	3 1/2"	5 1/4"	7"
11 7/8"	HUS1.81/10	HHUS410	HGUS5.50/12	HGUS7.25/12
14"	HUS1.81/10	HHUS410	HGUS5.50/14	HGUS7.25/14

**MAIN FLOOR FRAMING PLAN**



**LONGITUDE**  
ONE TWENTY  
ENGINEERING & DESIGN

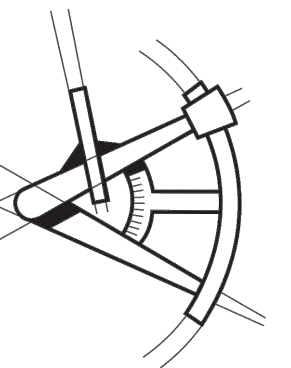

REVISIONS

DESCRIPTION	DATE	BY

PROJECT NAME

QUI RESIDENCE REMODEL

8028 SE 36TH ST  
MERCER ISLAND,  
WA 98040

PROJECT NUMBER

S200831-6

DRAWN BY - MRT

CHECKED BY - MRT

SHEET DATE - 9-2-2020

SCALE

24X36 SHEET: 1/4" = 1'-0"

DESCRIPTION

**MAIN FLOOR FRAMING PLAN**

SHEET **S-4**

SEE FOUNDATION NOTES IF  
POST-INSTALLED FOR ANCHOR  
GUIDELINES/SPECIFICATIONS

SHEAR WALL SCHEDULE

WALL	SHEATHING	PANEL EDGE NAILING (COMMON OR GALV BOX NAILS)	PANEL EDGE STUDS	ANCHOR BOLTS 5/8"Ø EMBED 7"	RIM CONNECTION		
					AT MUD SILL/ PLATE	AT ROOF EAVE TOP PLATE	AT SILL PLATE (SINKER NAIL .148Ø x 3 1/4")
SW6	7/16" APA PLY ONE SIDE	8d AT 6" O.C.	2x	48" O.C. IN 2x PLATE	LTP4 AT 24" O.C.	RBC AT 16" O.C.	16d AT 6" O.C.
SW4	7/16" APA PLY ONE SIDE	8d AT 4" O.C.	2x	32" O.C. IN 2x PLATE	LTP4 AT 16" O.C.	RBC AT 12" O.C.	16d AT 4" O.C.
SW3	7/16" APA PLY ONE SIDE	8d AT 3" O.C.	3x	16" O.C. IN 2x PLATE	LTP4 AT 16" O.C.	RBC AT 8" O.C.	16d AT 3" O.C.
SW2	7/16" APA PLY ONE SIDE	8d AT 2" O.C.	3x	12" O.C. IN 2x PLATE	LTP4 AT 12" O.C.	RBC AT 8" O.C.	16d AT 2" O.C.
2W4	7/16" APA PLY TWO SIDES	8d AT 4" O.C. EA SIDE	3x	24" O.C. IN 3x PLATE	LTP4+A35 @ 16" O.C. EA SIDE	N.A. AT ROOF EAVE	(2) ROWS 16d AT 4" O.C.
2W3	7/16" APA PLY TWO SIDES	8d AT 3" O.C. EA SIDE	3x	16" O.C. IN 3x PLATE	LTP4+A35 @ 16" O.C. EA SIDE	N.A. AT ROOF EAVE	(2) ROWS 16d AT 3" O.C.
2W2	7/16" APA PLY TWO SIDES	8d AT 2" O.C. EA SIDE	3x	16" O.C. IN 3x PLATE	LTP4+A35 @ 12" O.C. EA SIDE	N.A. AT ROOF EAVE	(2) ROWS 16d AT 2" O.C.

NOTES: 1) FOR NON-SHEAR WALL, PROVIDE ANCHOR BOLTS @ 72" O.C.

WALL FRAMING AND SHEAR  
WALL NOTES

- GENERAL STRUCTURAL NOTES AND ABBREVIATIONS PER SHEET S-1.
- VERIFY ALL DIMENSIONS AND ELEVATIONS WITH ARCH.
- LUMBER GRADE PER GENERAL STRUCTURAL NOTES.
- ALL BUNDLED STUDS SPECIFIED PER PLAN SHALL BE CONNECTED TOGETHER WITH 16d @ 6" O.C.
- EXTERIOR WALL STUDS SHALL BE 2X6 @ 16" O.C. ( $\leq 10'$ ), 2X6 @ 12" O.C. ( $> 10'$ ) UNO. INTERIOR WALL STUDS SHALL BE 2X4 @ 16" O.C. UNO. ALL INTERIOR NON-BEARING WALLS TO BE FRAMED MIN 0.25" UNDER FLOOR SYSTEM.
- PROVIDE ONE KING STUD AND ONE JACK STUD MINIMUM AT EVERY HEADER UNO. JACK STUDS SHOULD BE CONTINUOUS TO THE FOUNDATION AND SHALL HAVE VERTICAL CRUSH BLOCKING WITHIN THE FLOOR FRAMING DEPTH MATCHING THE WIDTH OF JACK STUDS.
- SHEARWALL SHEATHING AND NAILING REQUIREMENTS PER SHEARWALL SCHEDULE. ALL EXTERIOR WALLS SHALL BE TYPE SW6 UNO.
- ALL SHEATHING PANEL EDGES TO OCCUR OVER STUDS, PLATES, RIMS OR HORIZONTAL BLOCKING. PANEL EDGE NAILING PER SHEARWALL SCHEDULE, FIELD NAILING AT 12" O.C. UNO.
- PROVIDE MIN TWO 2X STUDS AT EACH END OF SHEARWALL UNO. PROVIDE PANEL EDGE NAILING INTO EACH STUD AT END OF WALL.
- SHEARWALL PANEL EDGE STUDS INDICATE THE MINIMUM STUD WIDTH AT ABUTTING PANEL EDGES. TWO 2X STUDS ARE AN ACCEPTABLE ALTERNATE FOR 3X STUDS. TWO 2X STUDS ARE TO BE NAILED TOGETHER WITH TWO ROWS 10d NAILS AT 6" O.C. (4" O.C. @ SW2 AND 2W2). AT DOUBLE SIDED SHEARWALLS VERTICAL PANEL EDGES TO BE STAGGERED ON OPPOSITE SIDES OF THE WALL EXCEPT END OF SHEARWALL.
- LTP4 INSTALLED OVER PLYWOOD SHALL USE 8d COMMON NAILS (.131Ø X 2.5") LTP4 INSTALLED DIRECTLY AGAINST FRAMING MAY USE 8d SHORT (.131X 1.5") RBC INSTALLED DIRECTLY AGAINST FRAMING USE 10d SHORT (.148X 1.5").
- WINDOW STRAP INDICATES THAT A WINDOW IS INCORPORATED WITHIN THE SHEAR WALL. REFER TO FORCE-TRANSFER AROUND OPENING DETAIL FOR FRAMING REQUIREMENTS.
- STHD HOLD-DOWNS ARE DIMENSIONED TO CENTER OF STRAP. HDU/HD HOLLOW-DOWNS ARE DIMENSIONED TO CENTER OF ANCHOR BOLT.
- SILL ANCHOR BOLTS (J-BOLTS) SHALL BE ASTM F1554 (36KSI) HDG, ASTM A307 (36KSI) HDG OR SIM. ANCHOR BOLTS TO BE 5/8"Ø X 7" MIN EMBEDMENT. SPACING PER SHEARWALL SCHEDULE (72" O.C. MAX). EACH ANCHOR BOLT TO HAVE STANDARD HDG NUT AND WASHER INSTALLED OVER 3"X3"X1/4" HDG PLATE WASHER WITH AND EDGE OF THE PLATE WASHER LOCATED WITHIN 1/2" OF SHEATHED FACE OF WALL. FOR TWO-SIDED SHEARWALLS W/ 2X6 WALL FRAMING USE 4X4X1/4" PLATE WASHERS OR STAGGER ANCHOR BOLTS SO THAT EVERY OTHER PLATE WASHER IS LOCATED WITHIN 1/2" OF EACH FACE OF THE WALL.
- ALL HANGERS TO BE MANUFACTURED BY SIMPSON STRONG-TIE. INSTALLATION PER MANUFACTURER'S RECOMMENDATIONS. ALTERNATIVE SOLUTIONS SHALL BE SUBMITTED TO EOR FOR APPROVAL PRIOR TO INSTALLATION. REFER TO TYPICAL HANGER SCHEDULE FOR HANGER SIZE UNO ON PLAN OR DETAILS.
- FIRE-PROOFING AND MOISTURE-PROOFING REQUIREMENTS BY OTHERS.

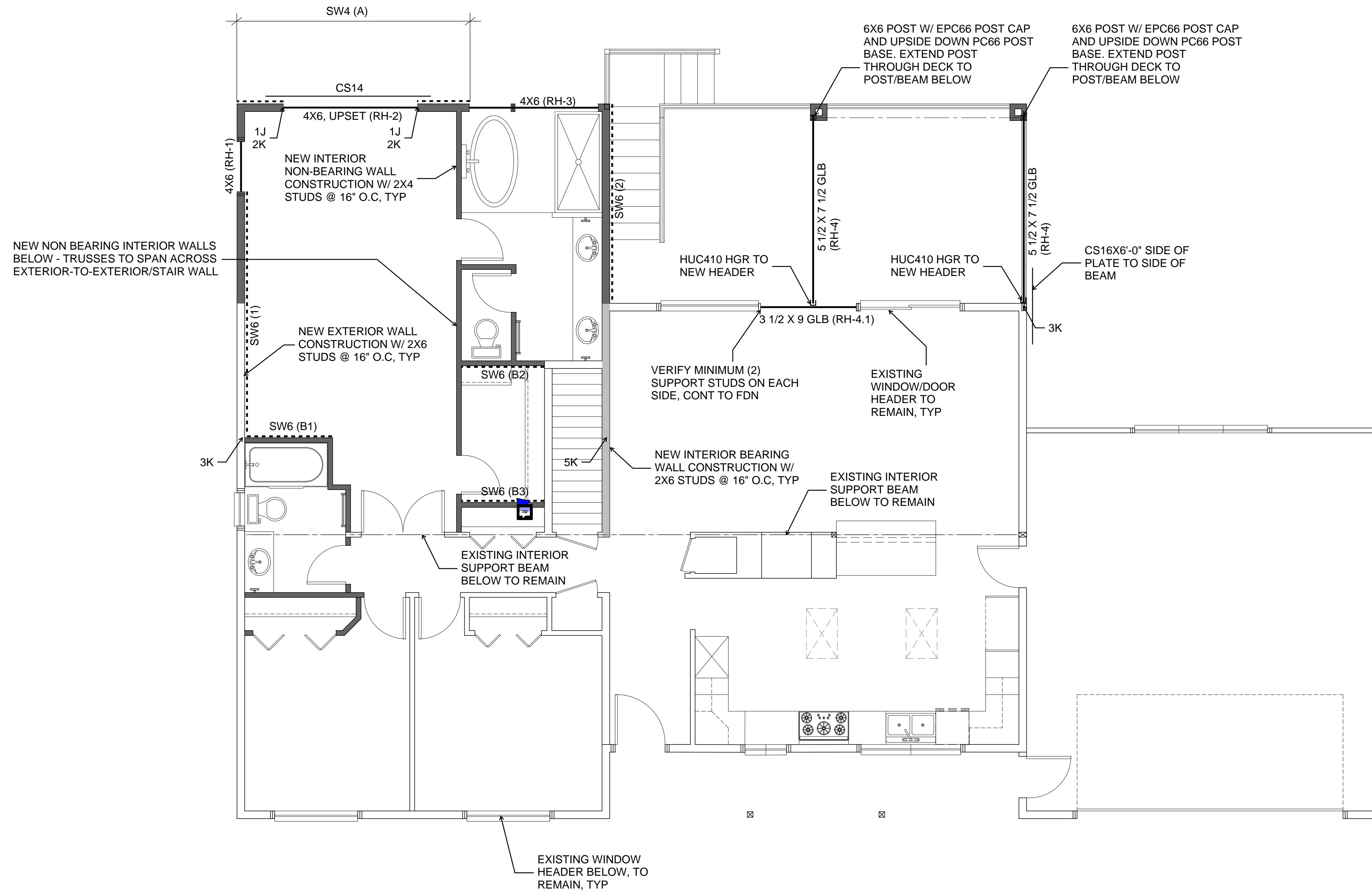

FRAMING AND SHEATHING LEGEND

- HOLD-DOWN BY SIMPSON (STHD/MST/HDU/HD, TYP)
- INDICATES THE NUMBER OF KING AND JACK STUDS
- INDICATES SHEARWALL LOCATION (SW# - SHEAR WALL MARK)
- HORIZONTAL STRAP (EXAMPLE)
- HEADER
- SHEAR WALL CALLOUT  
REFERENCE TO WALL DESIGNATION IN THE CALCULATION PACKAGE  
REFERENCE TO SHEAR WALL TYPE PER SHEAR WALL SCHEDULE
- EXAMPLE  
REFERENCE TO BEAM OR TRUSS CALCULATION IN  
CALCULATION PACKAGE  
BEAM OR TRUSS MEMBER

MAIN FLOOR WALL FRAMING & SHEAR-WALL PLAN



LONGITUDE  
ONE TWENTY  
ENGINEERING & DESIGN

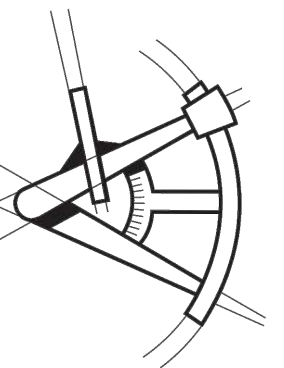

REVISIONS

DESCRIPTION DATE BY

PROJECT NAME

QUI RESIDENCE  
REMODEL

8028 SE 36TH ST  
MERCER ISLAND,  
WA 98040

PROJECT NUMBER

S200831-6

DRAWN BY - MRT

CHECKED BY - MRT

SHEET DATE - 9-2-2020

SCALE

24X36 SHEET: 1/4" = 1'-0"

MAIN FLOOR WALL FRAMING PLAN &  
SHEAR-WALL PLAN

DESCRIPTION SHEET S-5



# ROOF FRAMING NOTES

- GENERAL STRUCTURAL NOTES AND ABBREVIATIONS PER SHEET S-1.
- VERIFY ALL DIMENSIONS AND ELEVATIONS WITH ARCH.
- ROOF SHEATHING PER GENERAL NOTES. ALL SHEATHING TO BE GLUED AND NAILED TO FRAMING PER MANUFACTURER RECOMMENDATIONS. USE 8d COMMON NAILS (0.131" X 2 1/2") @ 6" O.C. AT PANEL EDGES AND AT ALL FRAMING DESIGNATED "WITH EDGE NAILING" OR "W/EN", AND 12" O.C. IN THE FIELD. UNO. PANEL EDGE JOINTS TO BE STAGGERED BETWEEN ADJACENT PANELS OF SHEATHING. PROVIDE GAP BETWEEN PANELS TO ALLOW FOR NATURAL EXPANSION/CONTRACTION (1/8" GAP TYP).
- ALL ROOF TRUSSES SHALL BE SPACED NO FURTHER APART THAN 24" O.C. AND SHALL BE CONNECTED TO TOP PLATE WITH H2.5 TIE UNO.
- ALL GIRDER TRUSSES SHALL BE CONNECTED TO TOP PLATE WITH TWO H6 TIES UNO.
- LOCATE ALL OPENINGS AND PENETRATIONS AND VERIFY NO CONFLICT WITH ROOF FRAMING. MECHANICAL, ELECTRICAL, AND PLUMBING DRAWINGS BY OTHERS.
- ALL BEAMS AND GIRDER TRUSSES SHALL BE SUPPORTED BY MIN TWO STUDS BELOW EACH END, UNLESS NOTED OTHERWISE ON PLAN. ALL BEAMS SHALL BE FRAMED FLUSH WITH JOISTS UNO. "DROPPED BEAM" OR "DB" INDICATES T/BEAM EQUAL B/JOISTS. "TOP FLUSH" OR "TF" INDICATES T/BEAM EQUAL T/JOISTS AND B/BEAM EXTENDING BELOW B/JOISTS. "BOTTOM FLUSH" OR "BF" INDICATES B/BEAM EQUAL B/JOISTS AND T/BEAM EXTENDING ABOVE T/JOISTS.
- ALL NON-BEARING WALLS TO BE FRAMED MIN 0.25" UNDER FLOOR SYSTEM.
- STUD QUANTITIES, POST SIZE, HOLDOWN, AND SHEARWALL REQUIREMENTS PER WALL FRAMING AND SHEARWALL PLAN BELOW.
- HORIZONTAL STRAPS INDICATED ON FRAMING PLANS SHALL BE CENTERED OVER THE TOP PLATE, BEAM, OR BLOCKING. STRAP LENGTH PER PLAN UNO.
- ALL HANGERS TO BE MANUFACTURED BY SIMPSON STRONG-TIE. INSTALLATION PER MANUFACTURER'S RECOMMENDATIONS. ALTERNATIVE SOLUTIONS SHALL BE SUBMITTED TO EOR FOR APPROVAL PRIOR TO INSTALLATION. REFER TO TYPICAL HANGER SCHEDULE FOR HANGER SIZE UNO ON PLAN OR DETAILS. HANGERS FOR ROOF TRUSSES BY OTHERS.
- ENGINEERED ROOF JOISTS AND ROOF TRUSSES TO BE DESIGNED BY OTHERS. REFER TO STRUCTURAL GENERAL NOTES FOR SUBMITTAL INFORMATION, AND DESIGN CRITERIA.
  - STANDARD DEAD AND LIVE LOADS SHALL BE USED FOR TRUSS DESIGN. REFERENCE STRUCTURAL GENERAL NOTES FOR MORE INFORMATION.
  - CHANGES TO LAYOUT MUST BE SUBMITTED TO THE ARCHITECT AND EOR FOR REVIEW AND APPROVAL.
  - TRUSS SUBMITTAL PACKAGE TO BE PROVIDED TO EOR FOR REVIEW. REFERENCE STRUCTURAL GENERAL NOTES FOR SUBMITTAL REQUIREMENTS.
  - (XXX LBS SHEAR/DRAW) INDICATES SHEAR TRANSFER LOAD. SHEAR TRUSS SHALL BE DESIGNED TO BE ABLE TO TRANSFER SPECIFIED LATERAL LOAD APPLIED AT THE TOP CHORD TO THE BOTTOM CHORD AND INTO SHEARWALL BELOW.
  - ROOF TRUSSES SHOULD BE DESIGNED FOR ADDITIONAL LOADS WHERE APPLICABLE AS SPECIFIED BY THE ARCHITECT (I.E. MECHANICAL UNITS, ROOF DECKS AND PATIOS, GREEN ROOFS, SOLAR UNITS AND ETC).
  - TRUSS DESIGN FOR BEARING AT TOP PLATES TO BE DESIGNED FOR COMPRESSION PERPENDICULAR TO GRAIN.
- FIRE-PROOFING AND MOISTURE-PROOFING REQUIREMENTS BY OTHERS.
- ROOF COVERINGS AND ROOFING MATERIAL BY OTHERS.
- ROOF DRAINAGE BY OTHERS.
- ATTIC VENTILATION BY OTHERS.

TYPICAL JOIST HANGER SCHEDULE			
TJ210			
11 7/8"	2-PLY 11 7/8"	14"	2-PLY 14"
IUS2.06/11.88	MIU4.28/11	IUS2.06/14	MIU4.28/14
2X8, 2X10 OR 2X12 (UNO PER PLAN)			
1-PLY		2-PLY	
LUS210		LUS210-2	

  

TYPICAL BEAM HANGER SCHEDULE			
LVL / LSL / PSL			
	1 3/4"	3 1/2"	5 1/4"
11 7/8"	HUS1.81/10	HHUS410	HGUS5.50/12
14"	HUS1.81/10	HHUS410	HGUS5.50/14

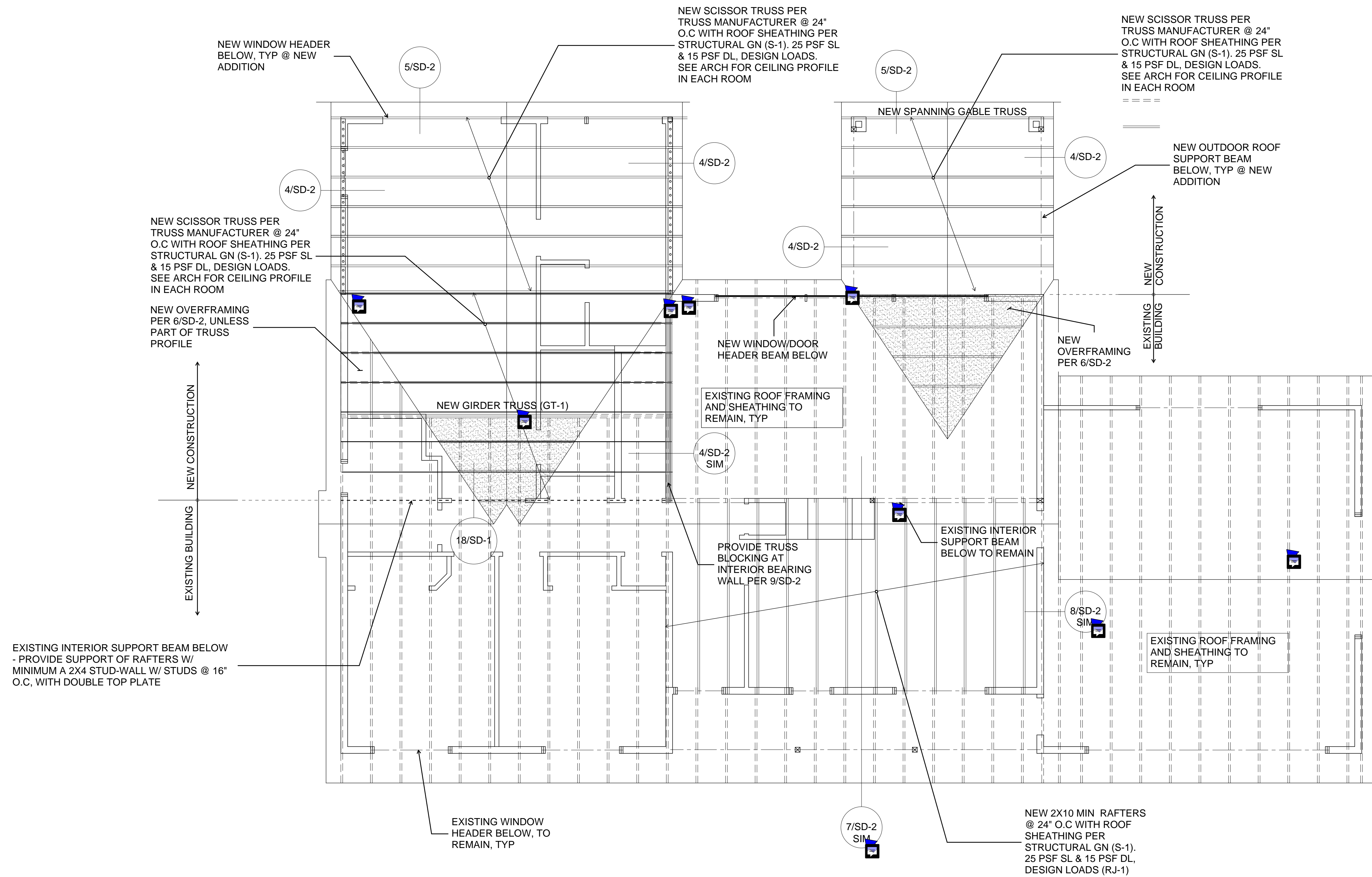

**ROOF FRAMING PLAN**

### FRAMING LEGEND

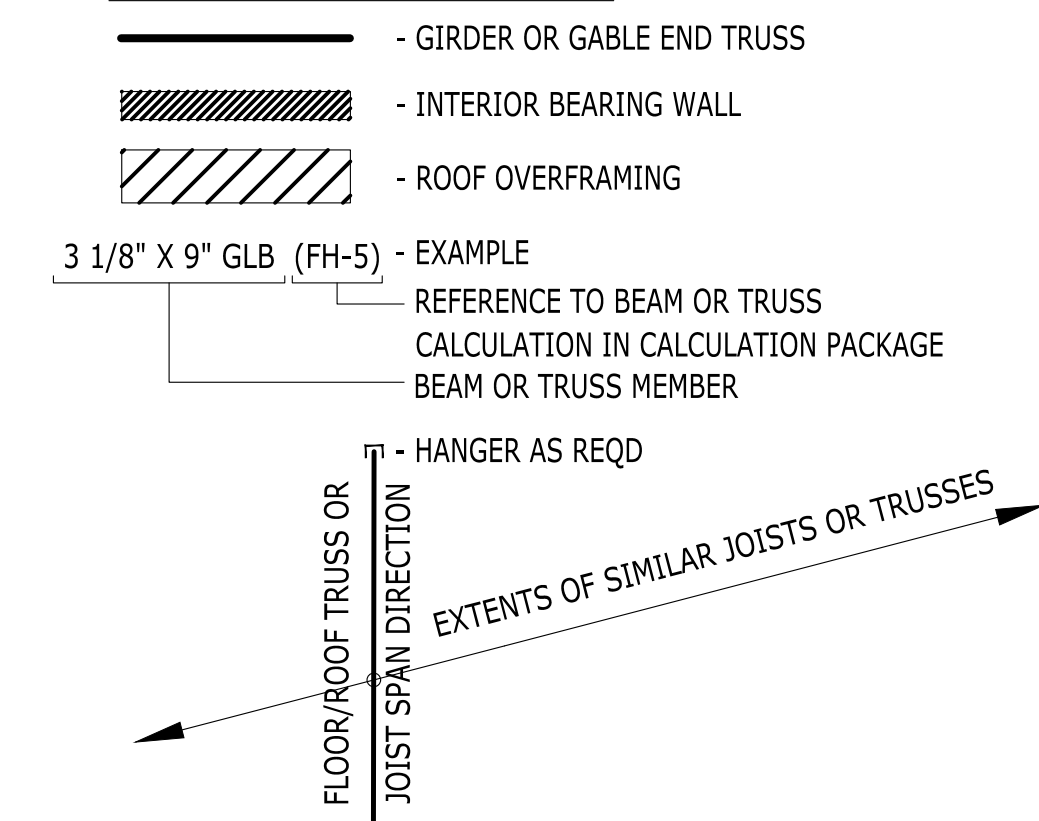

**LONGITUDE**  
ONE TWENTY<sup>°</sup>  
ENGINEERING & DESIGN

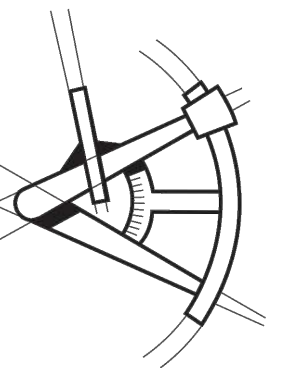

REVISIONS

DESCRIPTION	DATE	BY

PROJECT NAME

QUI RESIDENCE REMODEL  
8028 SE 36TH ST  
MERCER ISLAND, WA 98040  
PROJECT NUMBER

S200831-6

DRAWN BY - MRT

CHECKED BY - MRT

SHEET DATE - 9-2-2020

SCALE

24X36 SHEET: 1/4" = 1'-0"

ROOF FRAMING PLAN  
SHEET S-6



**LONGITUDE**  
**ONE TWENTY**<sup>®</sup>  
ENGINEERING & DESIGN

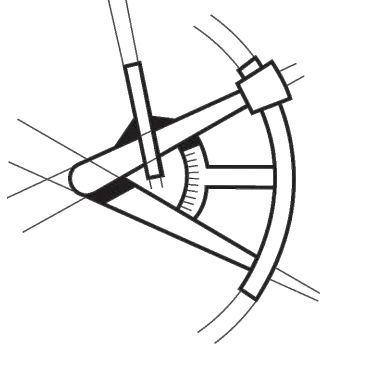

REVISIONS

DESCRIPTION	DATE	BY

PROJECT NAME

**QUI RESIDENCE REMODEL**

8028 SE 36TH ST  
MERCER ISLAND,  
WA 98040

PROJECT NUMBER

**S200831-6**

DRAWN BY - MRT

CHECKED BY - MRT

SHEET DATE - 9-2-2020

SCALE

24X36 SHEET: 1/4" = 1'-0"

DESCRIPTION

**STRUCTURAL DETAILS**

SHEET **SD-1**

**STEM WALL FOOTING SCHEDULE**

FOOTING WIDTH PER PLAN	FOOTING DEPTH	LONGITUDINAL REINFORCEMENT	TRANSVERSE REINFORCEMENT
1'-4"	8"	(2)#4, CONT	N/A
1'-6"	8"	(3)#4, CONT	N/A
1'-6"	10"	(3)#4, CONT	#4@12" O.C.

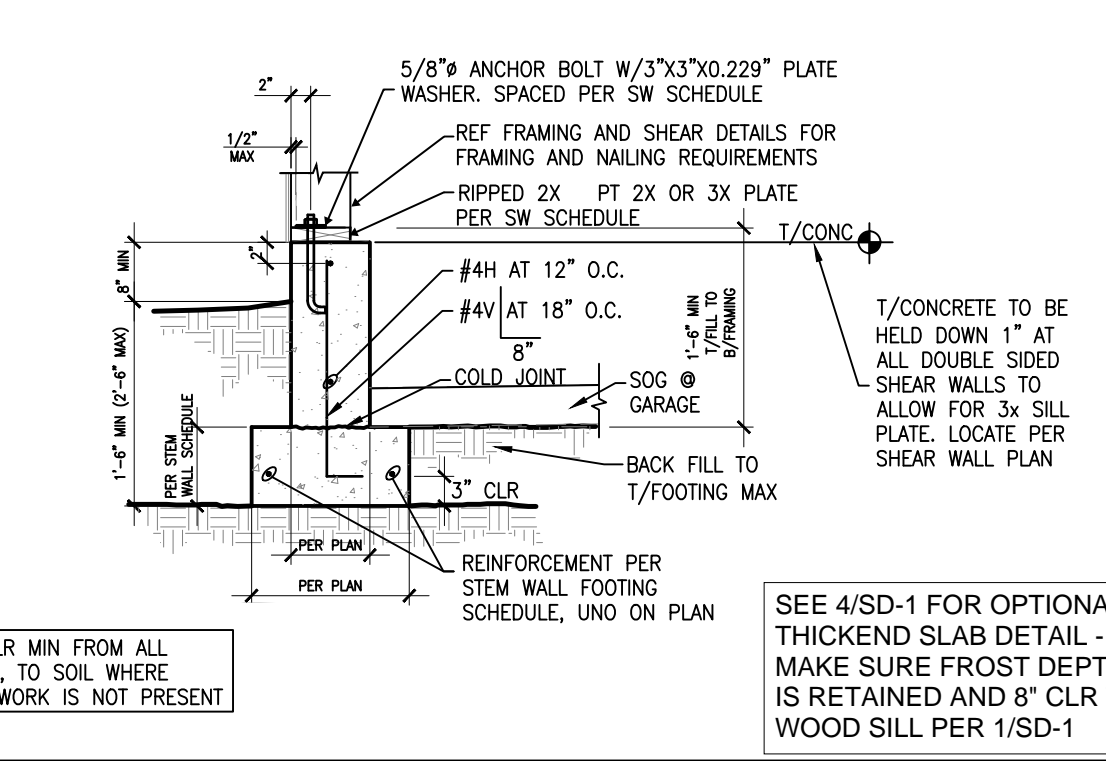

**1 STEM WALL AT EXTERIOR**

**ISOLATED FOOTING SCHEDULE**

FOOTING SIZE PER PLAN	REINFORCEMENT
24" X 24" X 10"	(3)#4, EA WAY, BTM
30" X 30" X 10"	(3)#4, EA WAY, BTM
36" X 36" X 12"	(4)#4, EA WAY, BTM
48" X 48" X 12"	(5)#4, EA WAY, TOP/BTM
60" X 36" X 12"	(6)#4 SHORT, (4)#4 LONG, BTM

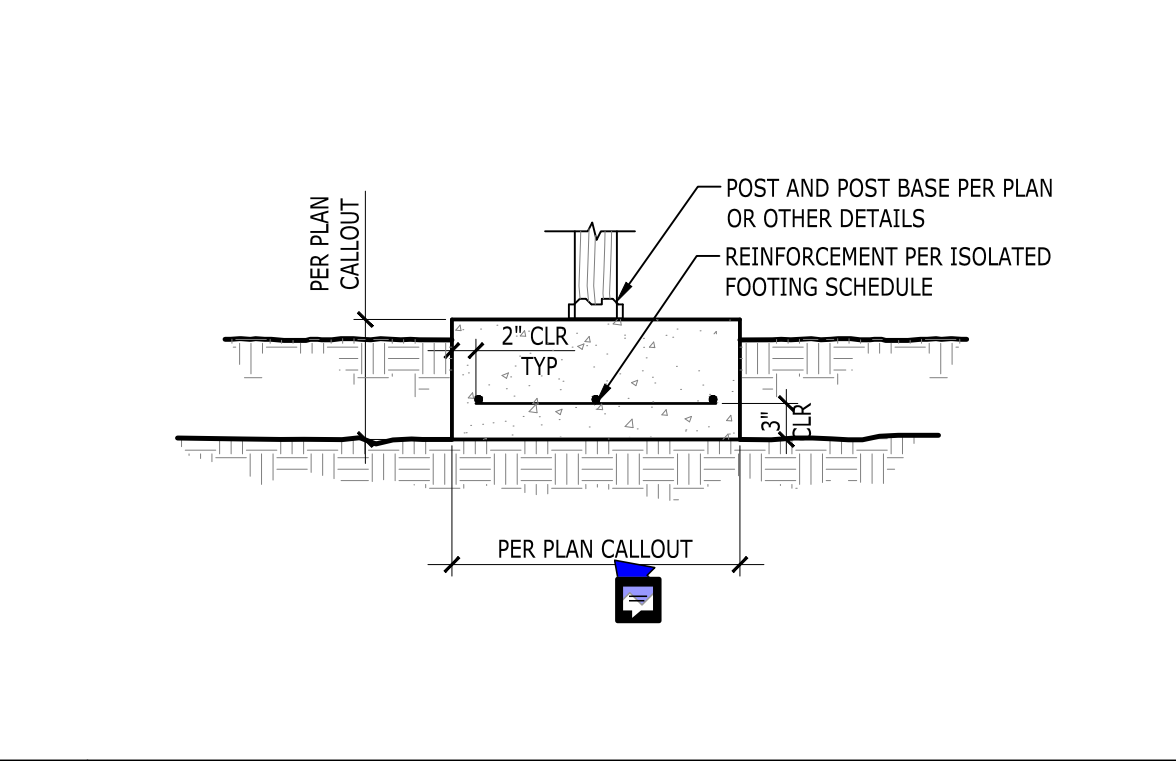

**2 ISOLATED INTERIOR FOOTING**

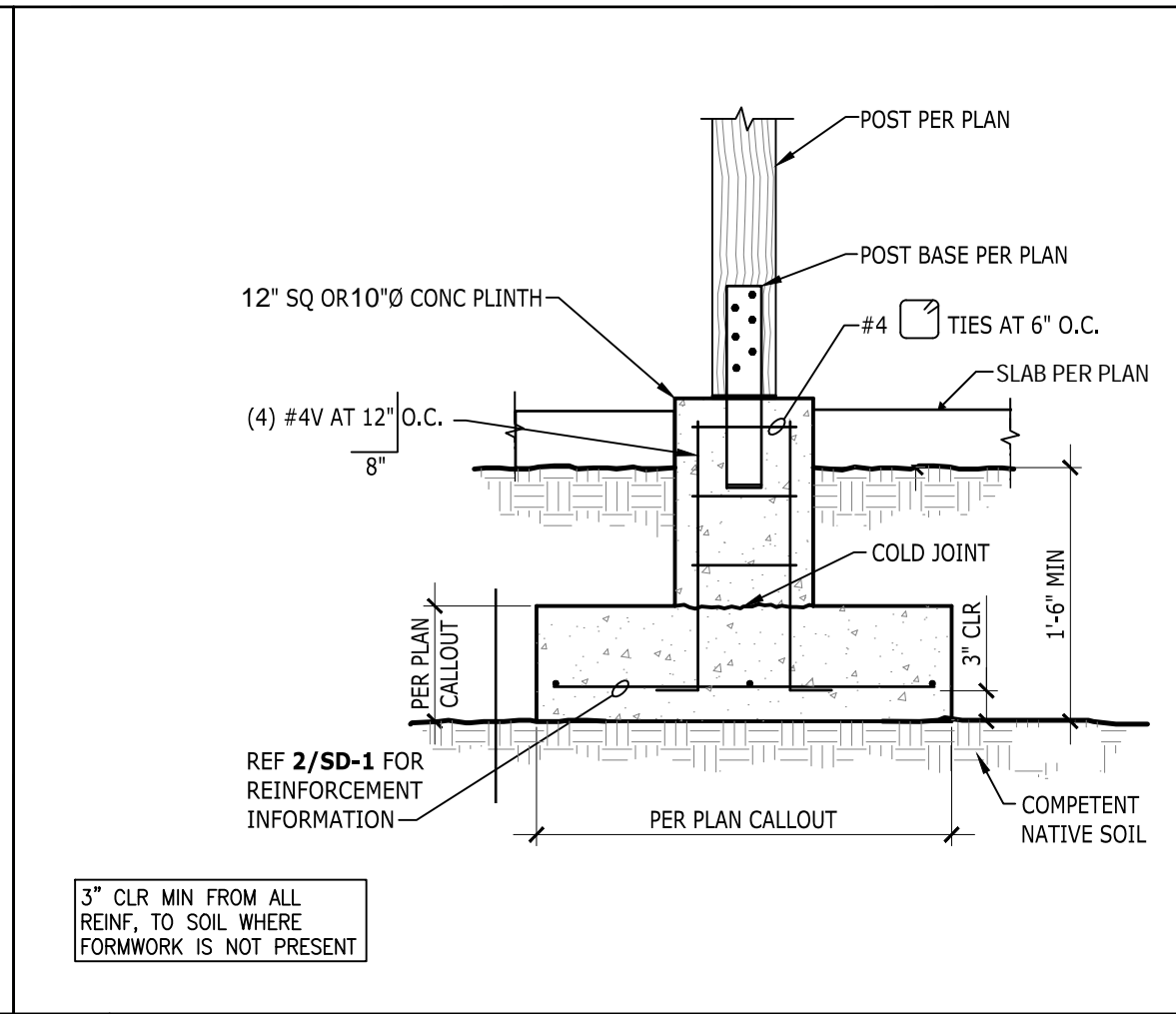

**3 ISOLATED EXTERIOR FOOTING**

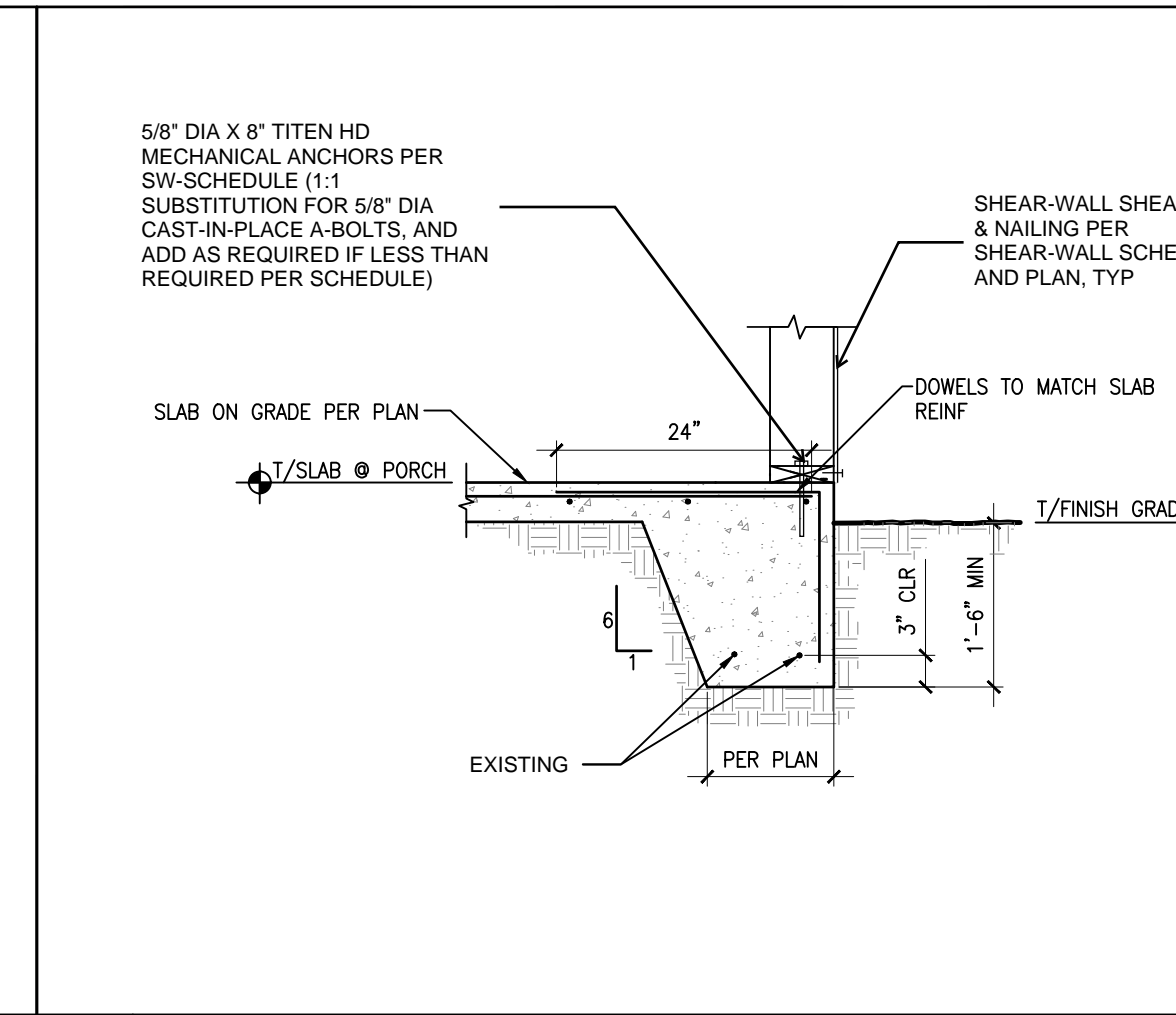

**4 TYPICAL THICKENED SLAB EDGE TURN DOWN**

**LAP SPLICE AND STANDARD HOOK LENGTH FOR CORNER BARS**

BAR SIZE PER WALL	LAP SPLICE LENGTH	STD HOOK LENGTH
#4	2'-6"	0'-8"
#5	3'-0"	0'-10"
#6	3'-8"	1'-0"
#8	5'-0"	1'-3"

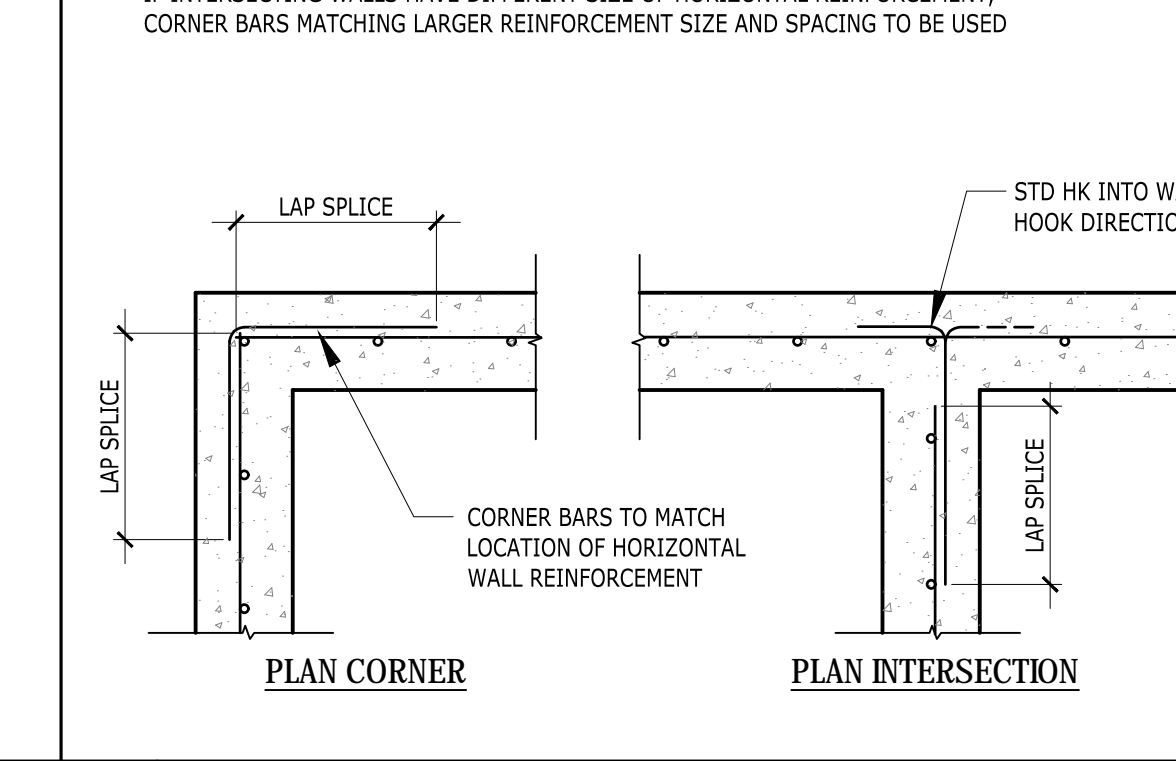

**5 CORNER BARS AT CONCRETE WALLS**

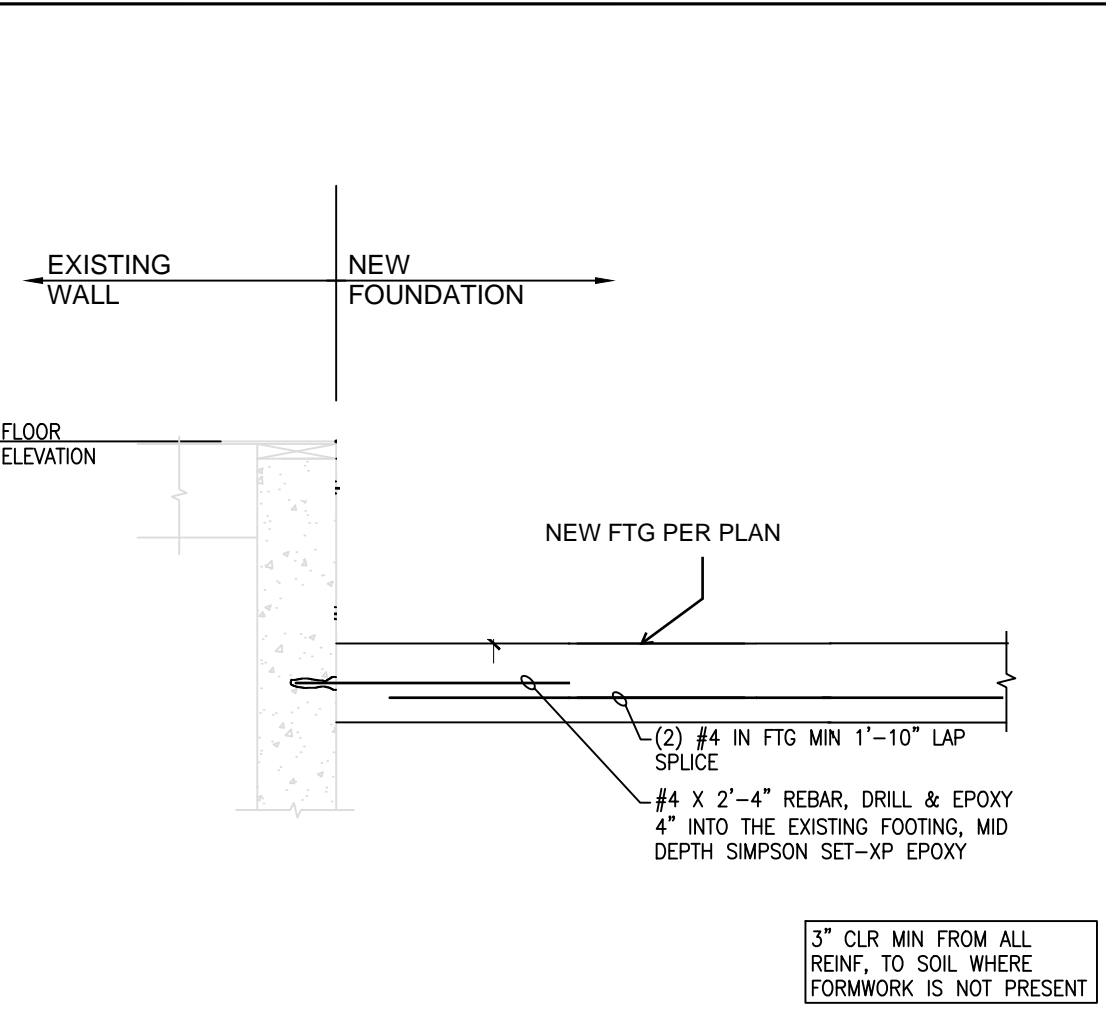

**7 CONSTRUCTION/CONTROL JOINT DETAILS**

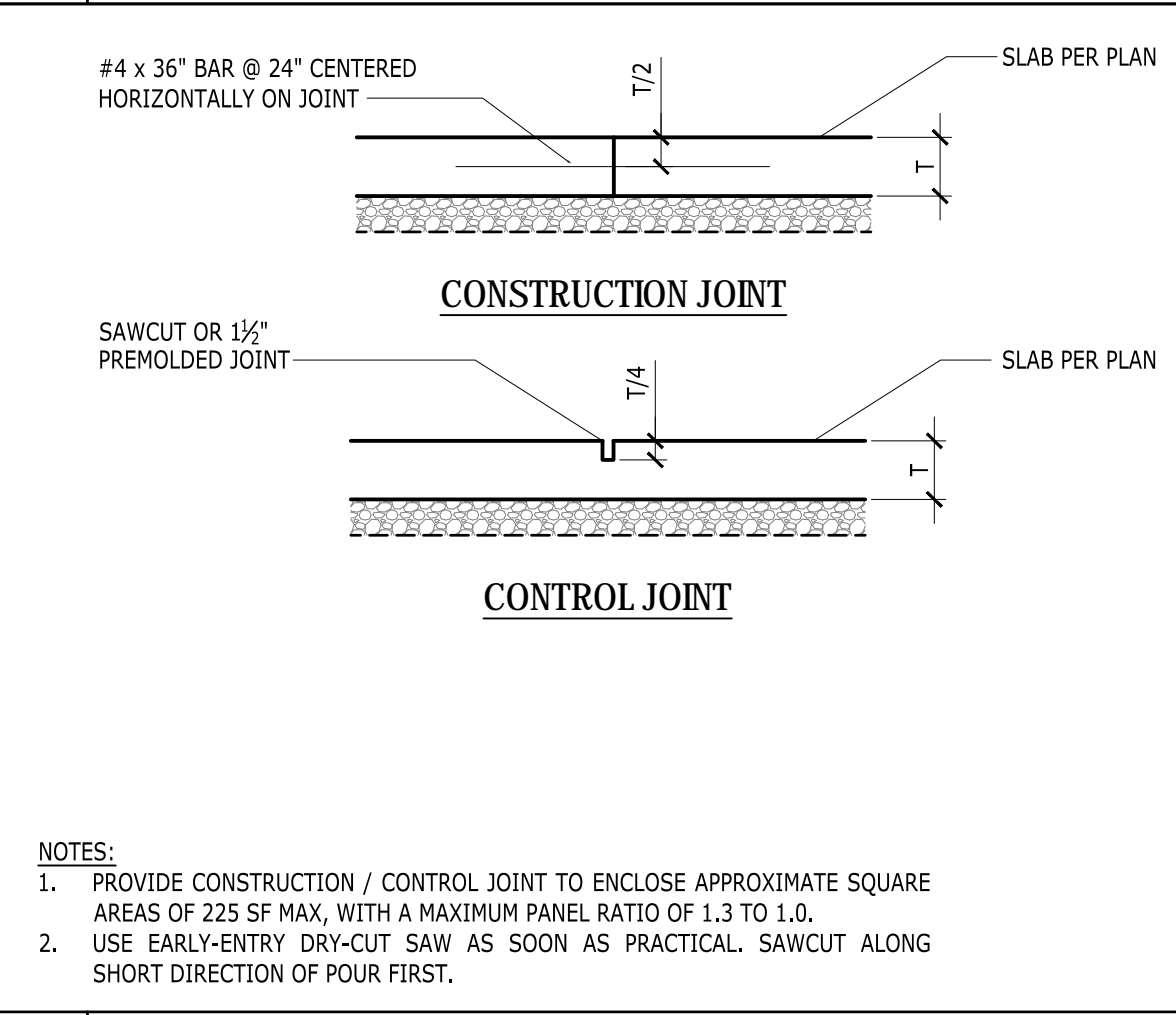

**8 BAR BEND AND HOOK DETAILS**

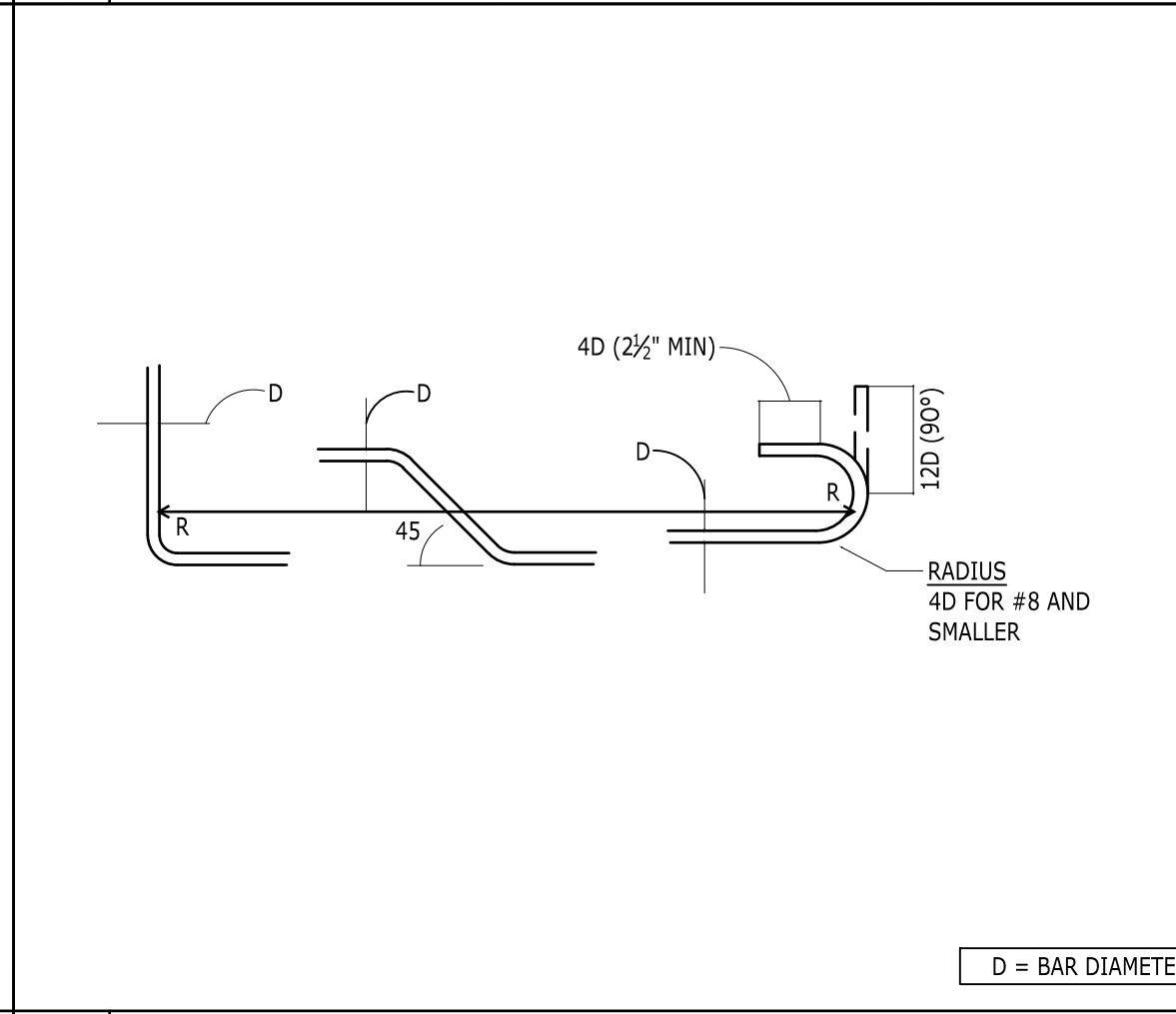

**9 THICKENED SLAB/FTG UNDER BEARING WALL**

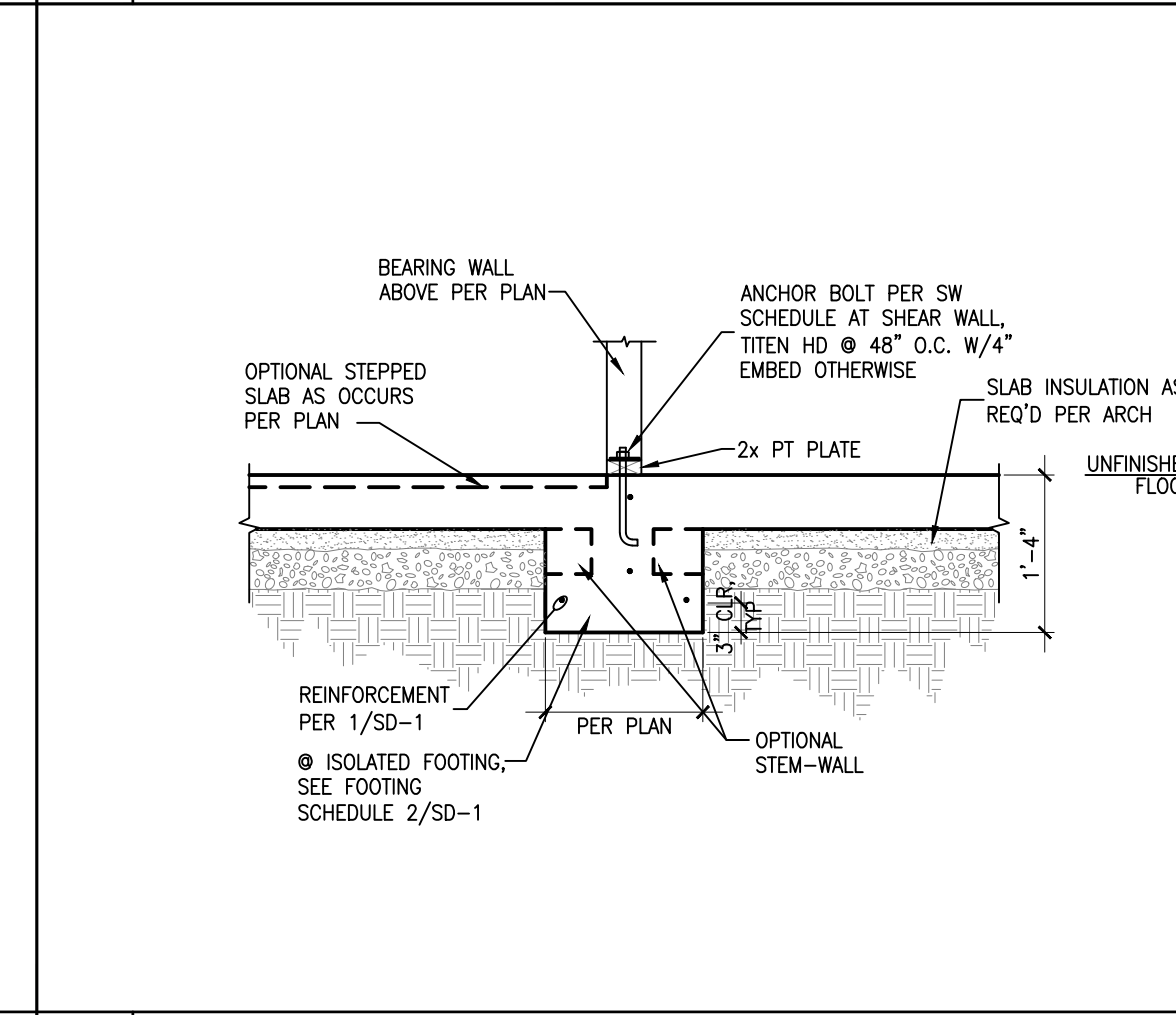

**15 HOLD-DOWN DETAIL**

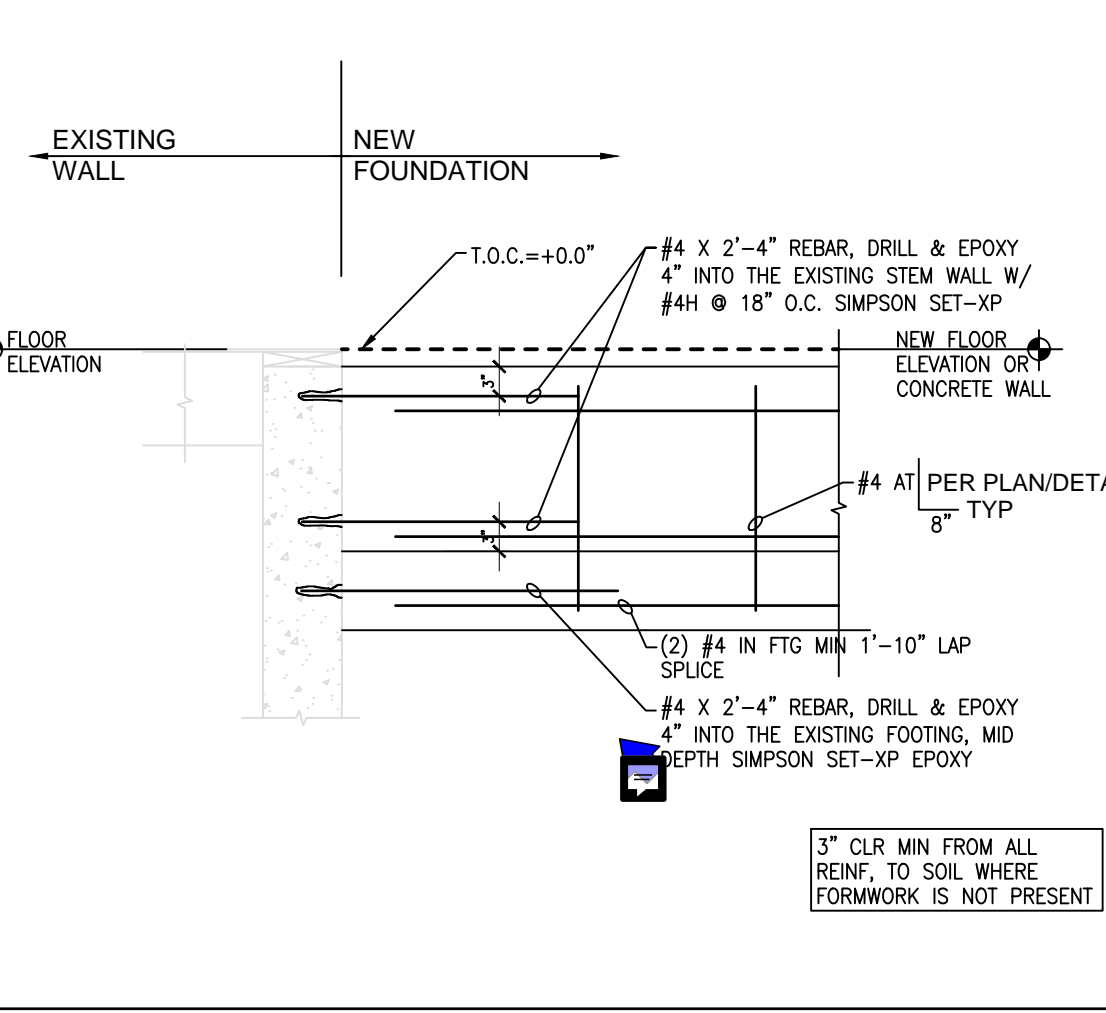

**11 FOUNDATION DETAIL**

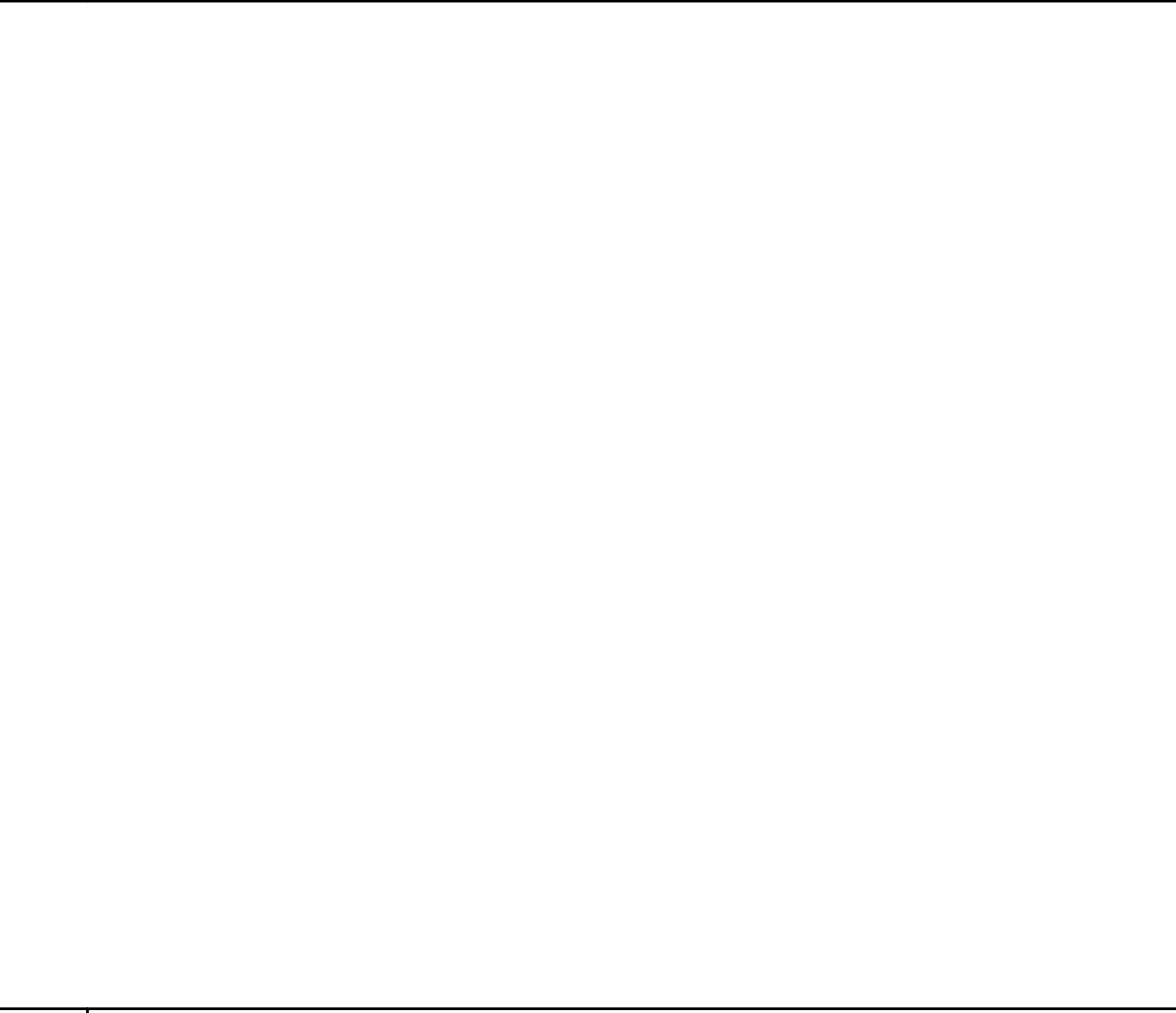

**13 BEAM AT DISCONTINUOUS TOP PLATES**

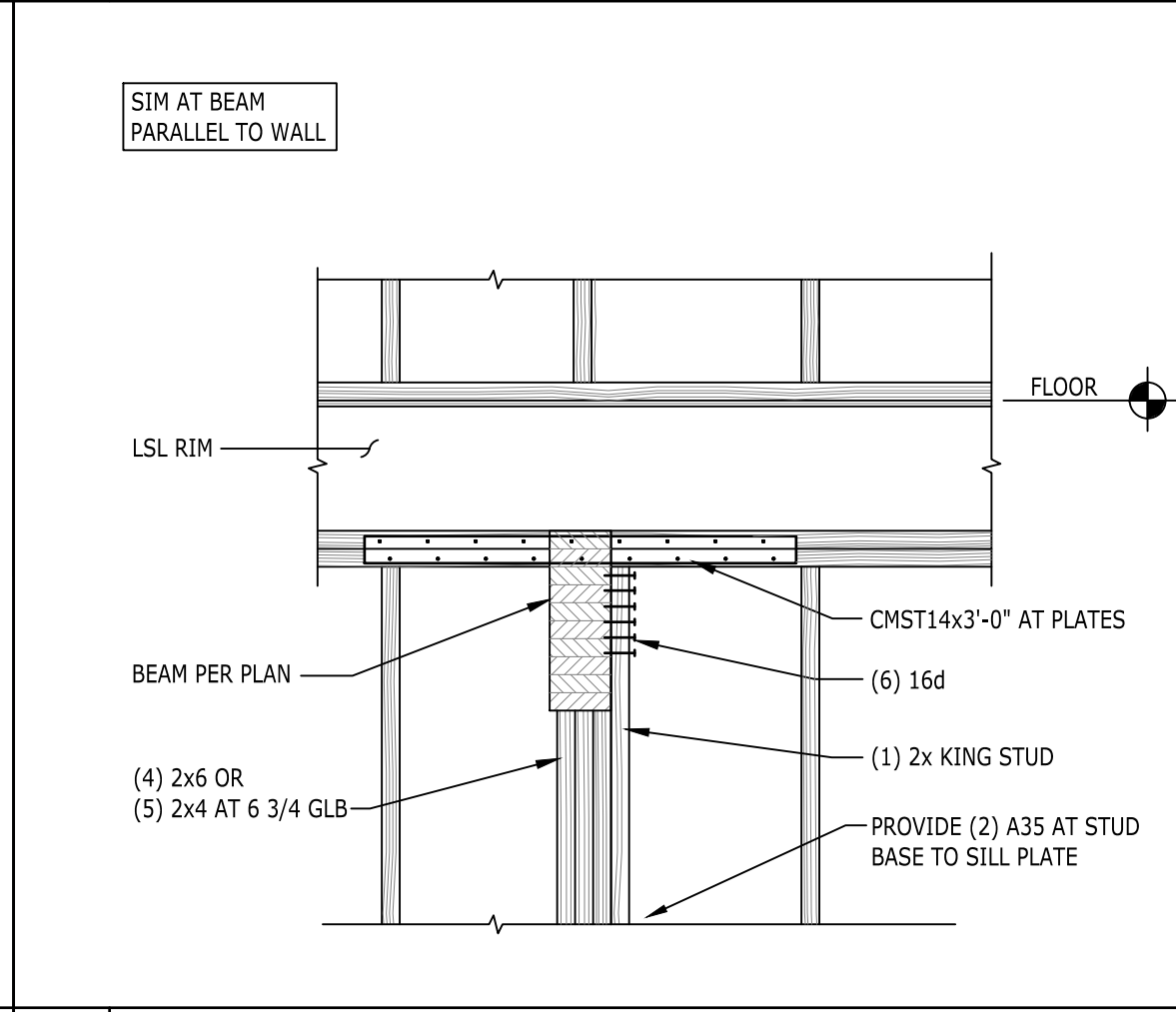

**17 CEILING FRAMING AT NON-BEARING WALL**

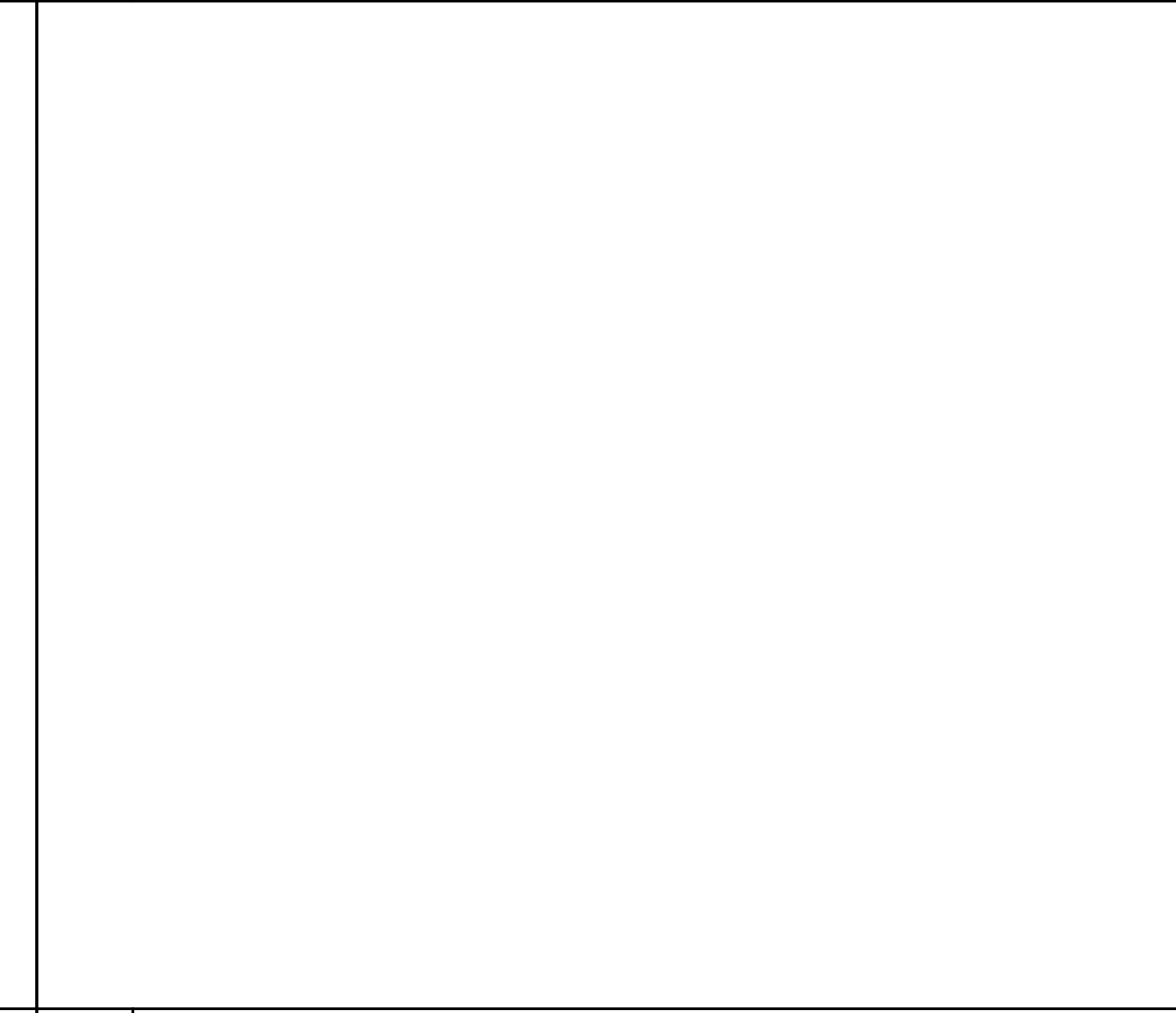

**18 FLOOR FRAMING AT INTERIOR BEARING WALL**

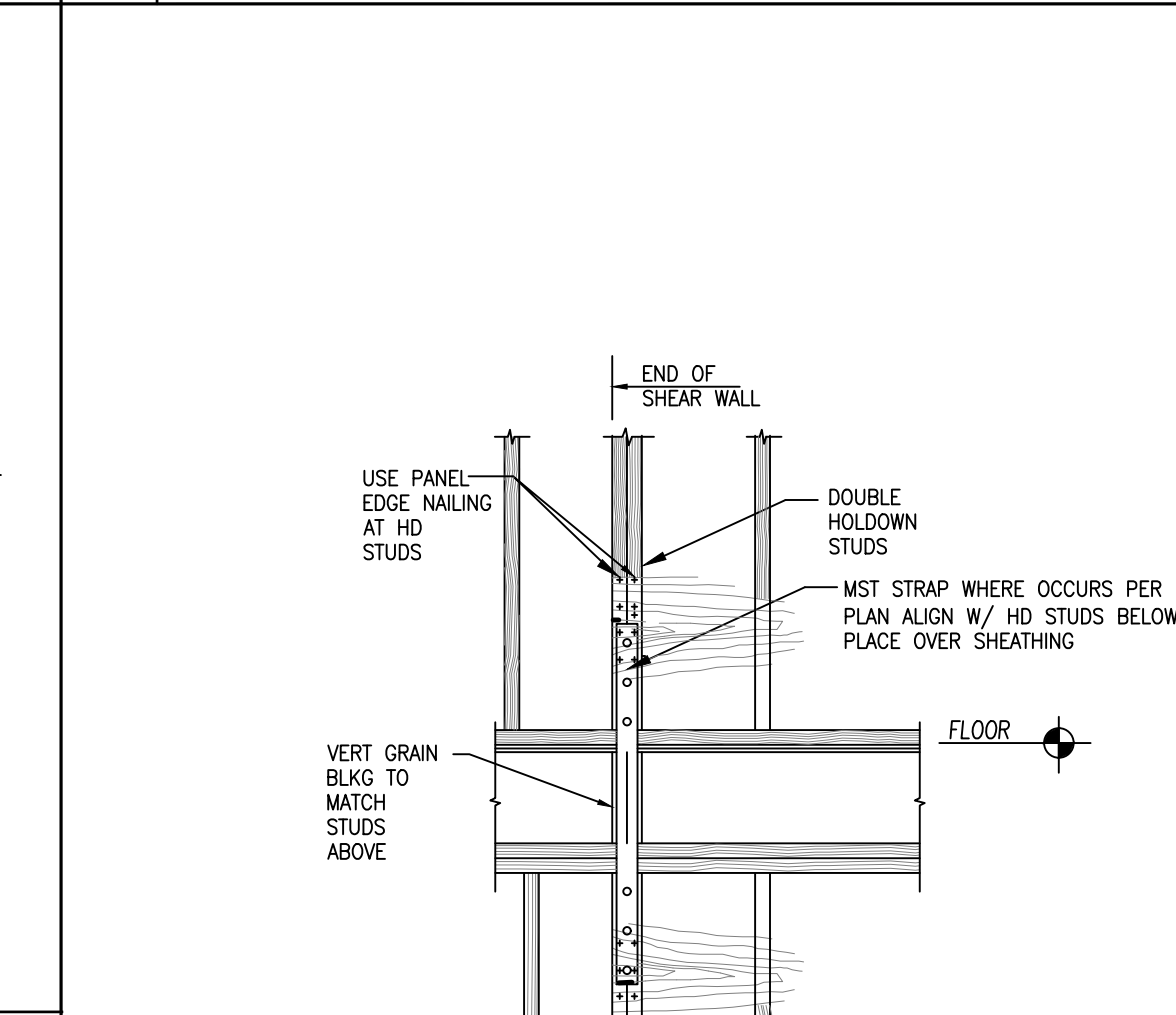

**19 FLOOR TO BEAM CONNECTION**

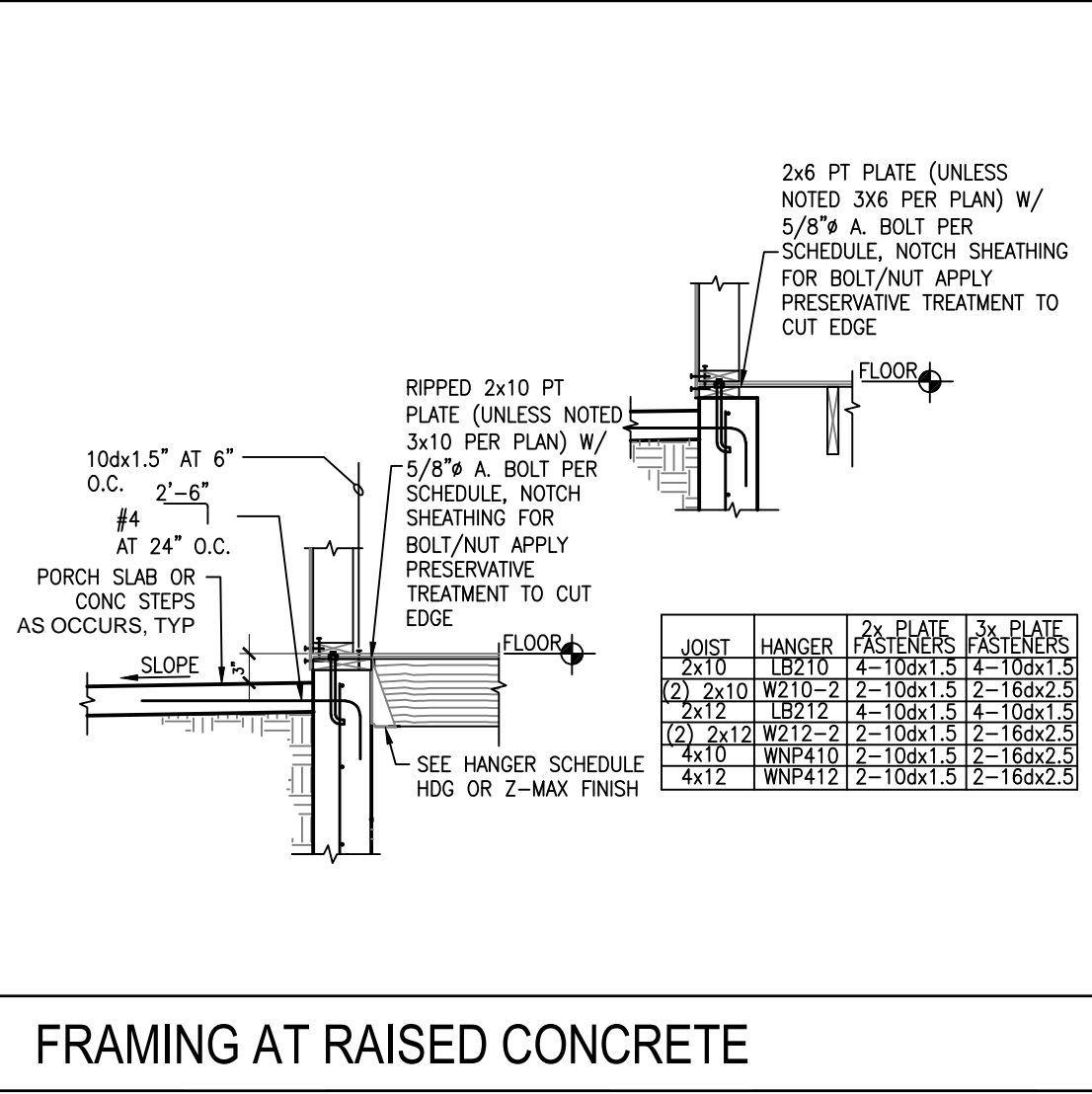

**16 FRAMING AT RAISED CONCRETE**

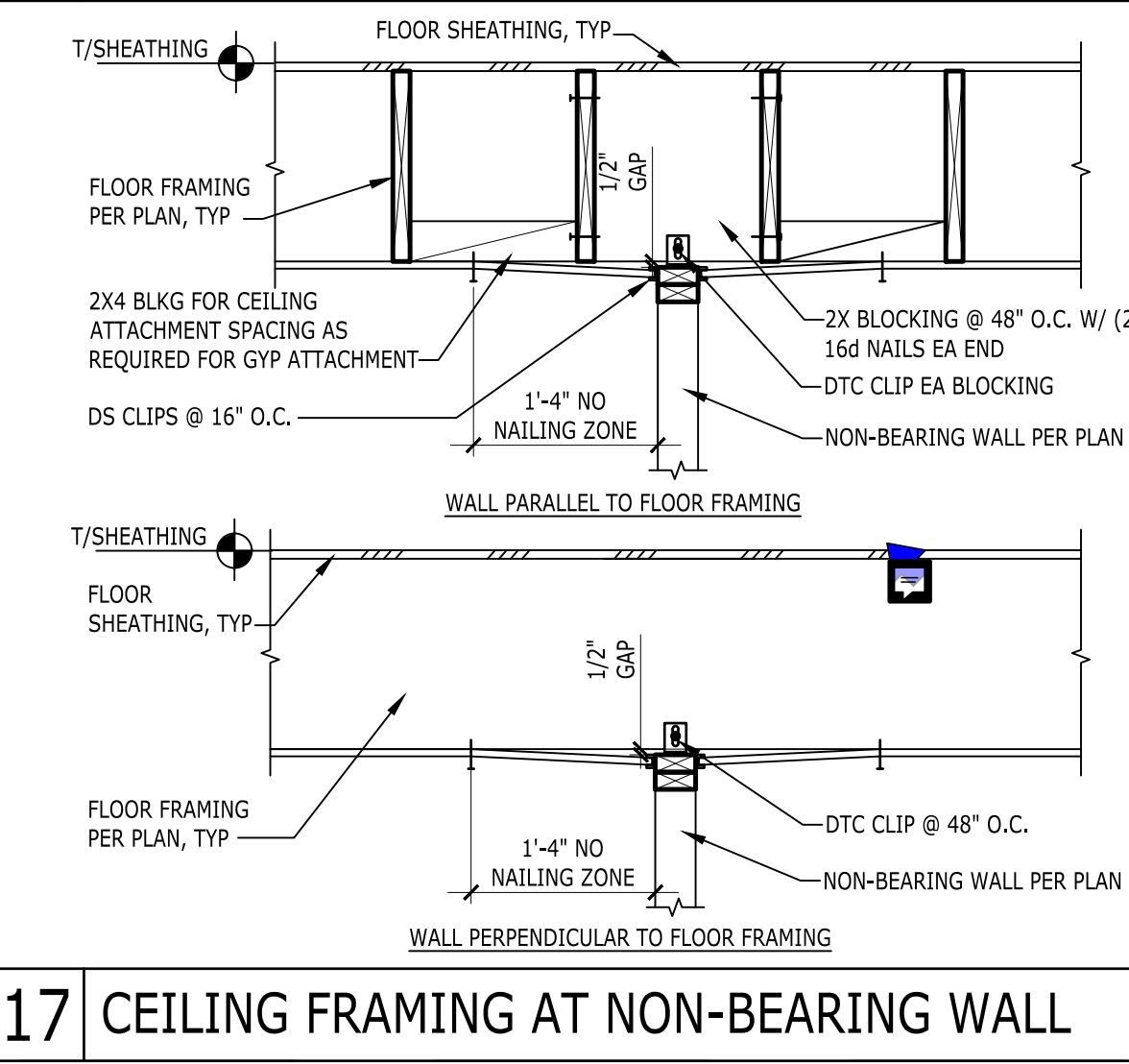

**17 CEILING FRAMING AT NON-BEARING WALL**

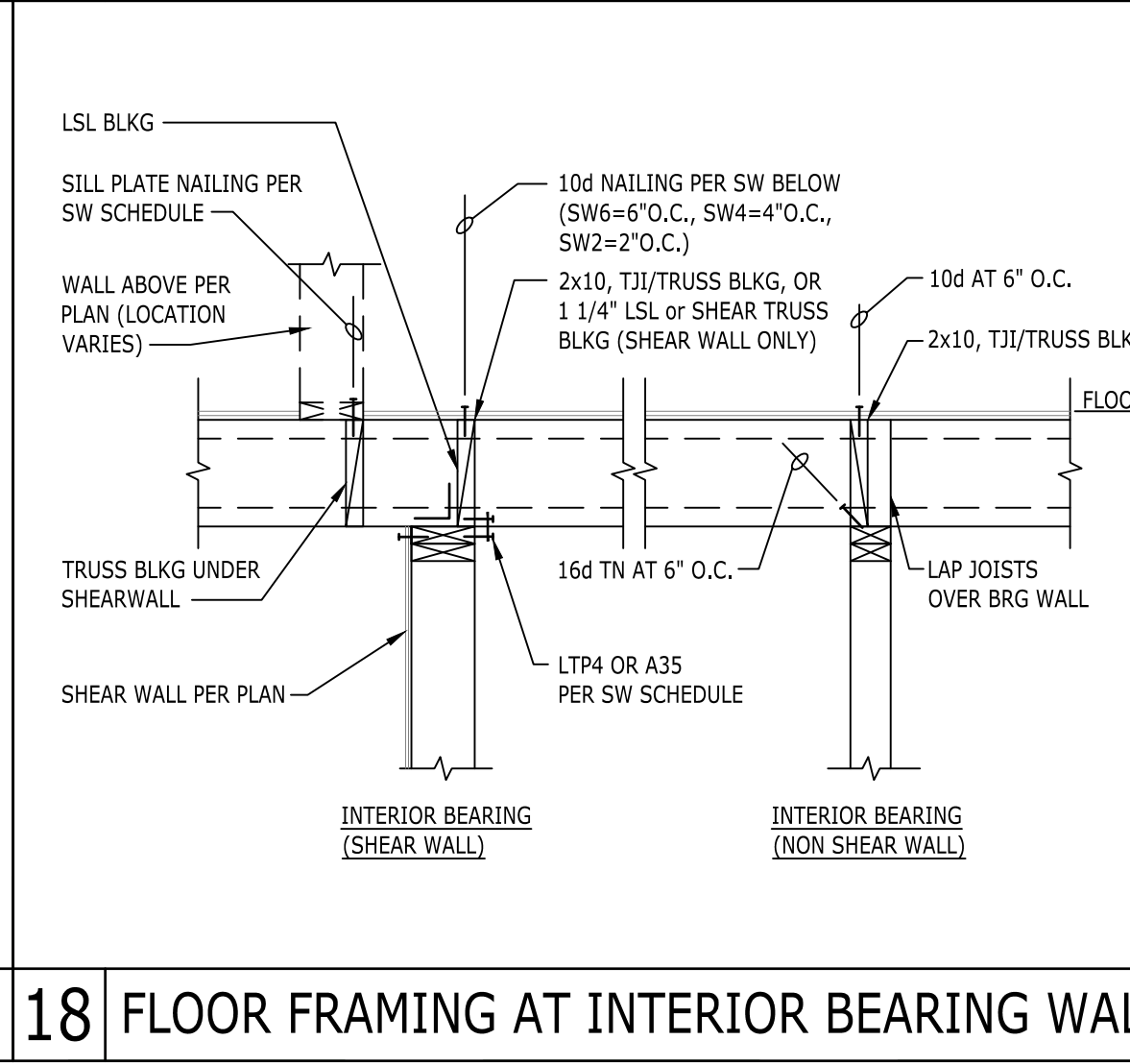

**18 FLOOR FRAMING AT INTERIOR BEARING WALL**

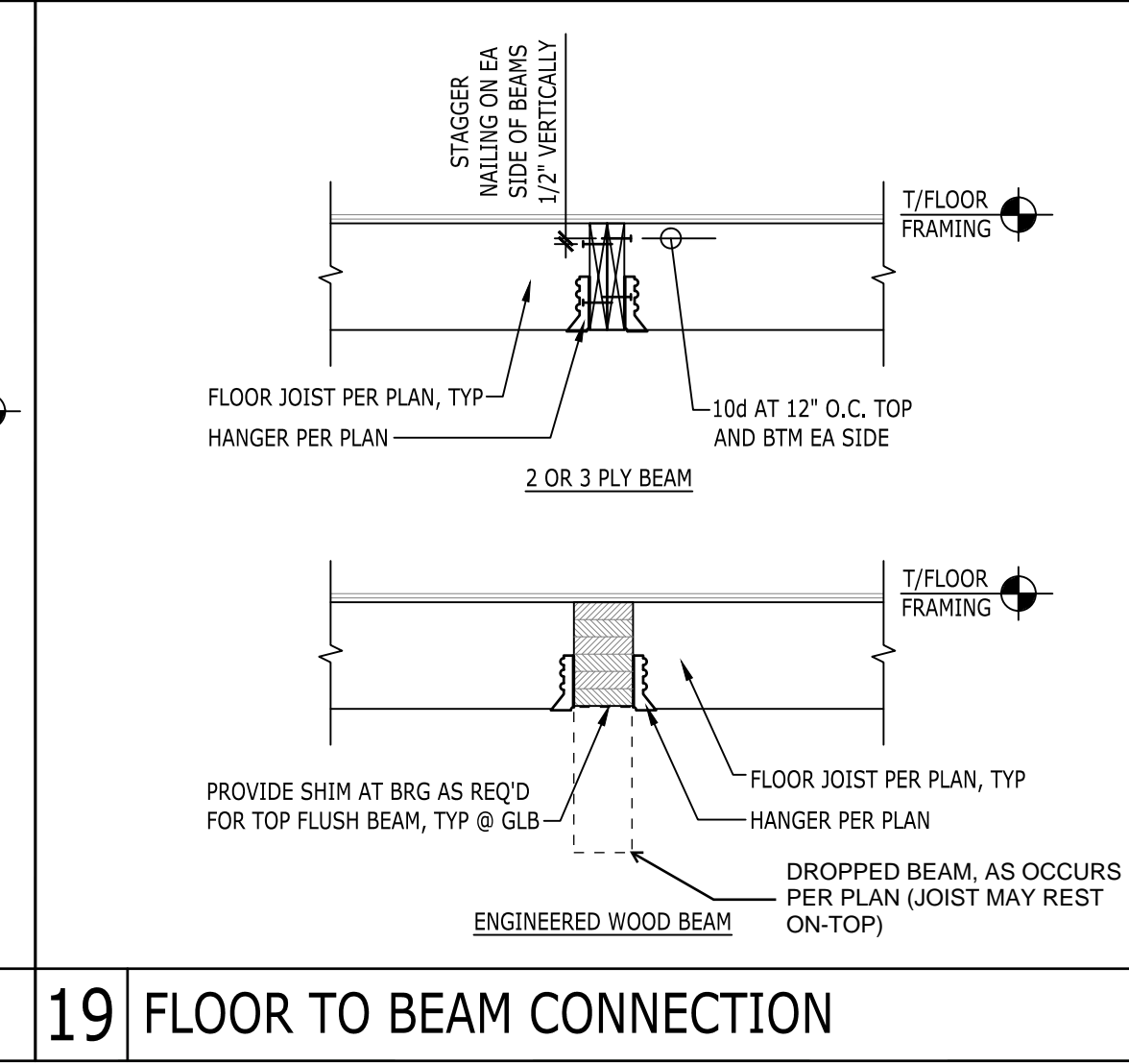

**19 FLOOR TO BEAM CONNECTION**

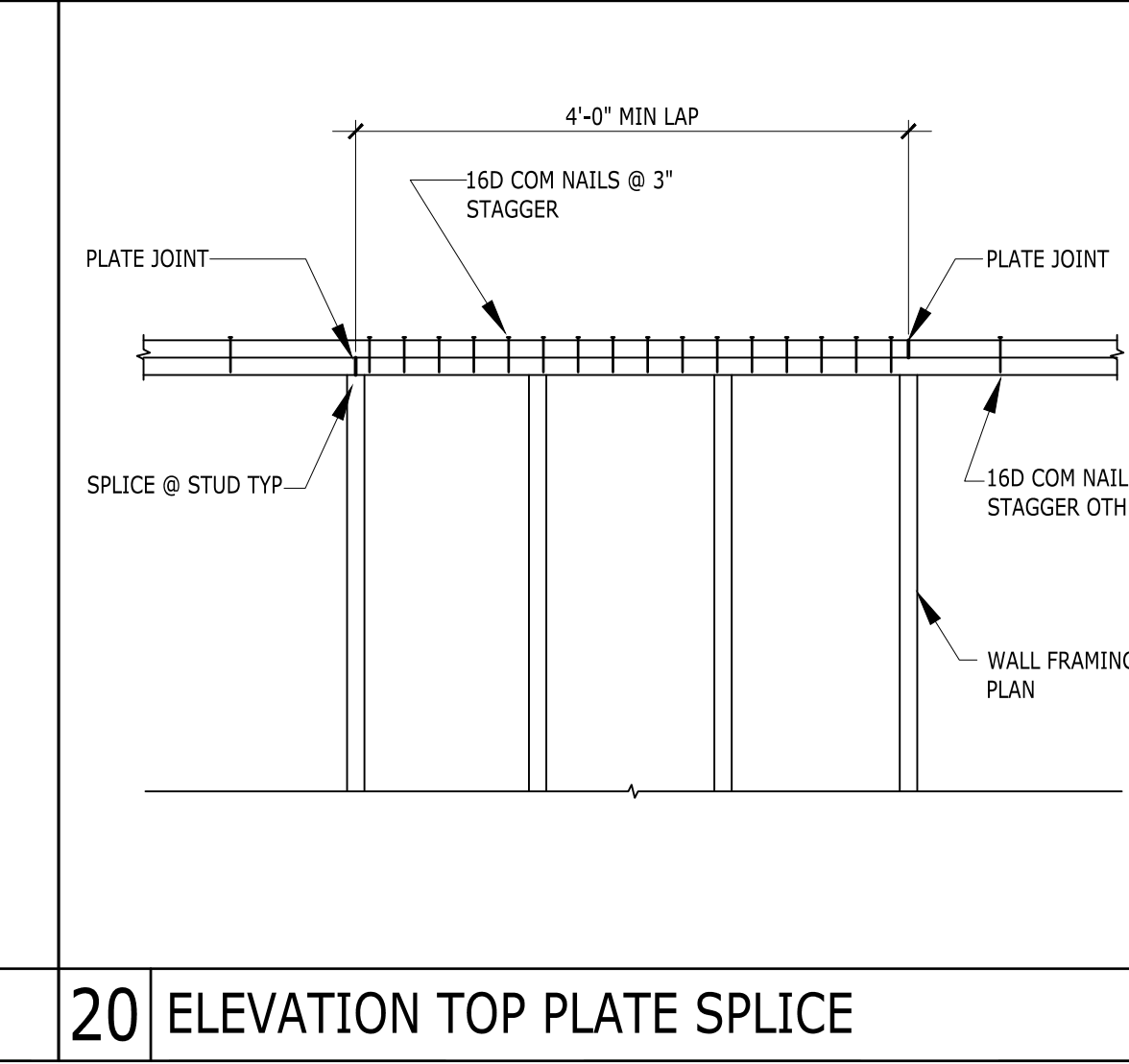

**20 ELEVATION TOP PLATE SPLICE**



LONGITUDE  
ONE TWENTY  
ENGINEERING & DESIGN

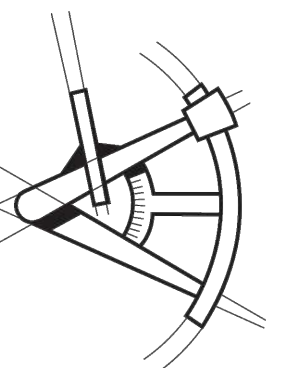

REVISIONS

DESCRIPTION DATE BY

PROJECT NAME

QUI RESIDENCE

REMODEL

8028 SE 36TH ST

MERCER ISLAND,

WA 98040

PROJECT NUMBER

S200831-6

DRAWN BY - MRT

CHECKED BY - MRT

SHEET DATE - 9-2-2020

SCALE

24X36 SHEET: 1/4" = 1'-0"

STRUCTURAL DETAILS

SHEET SD-2

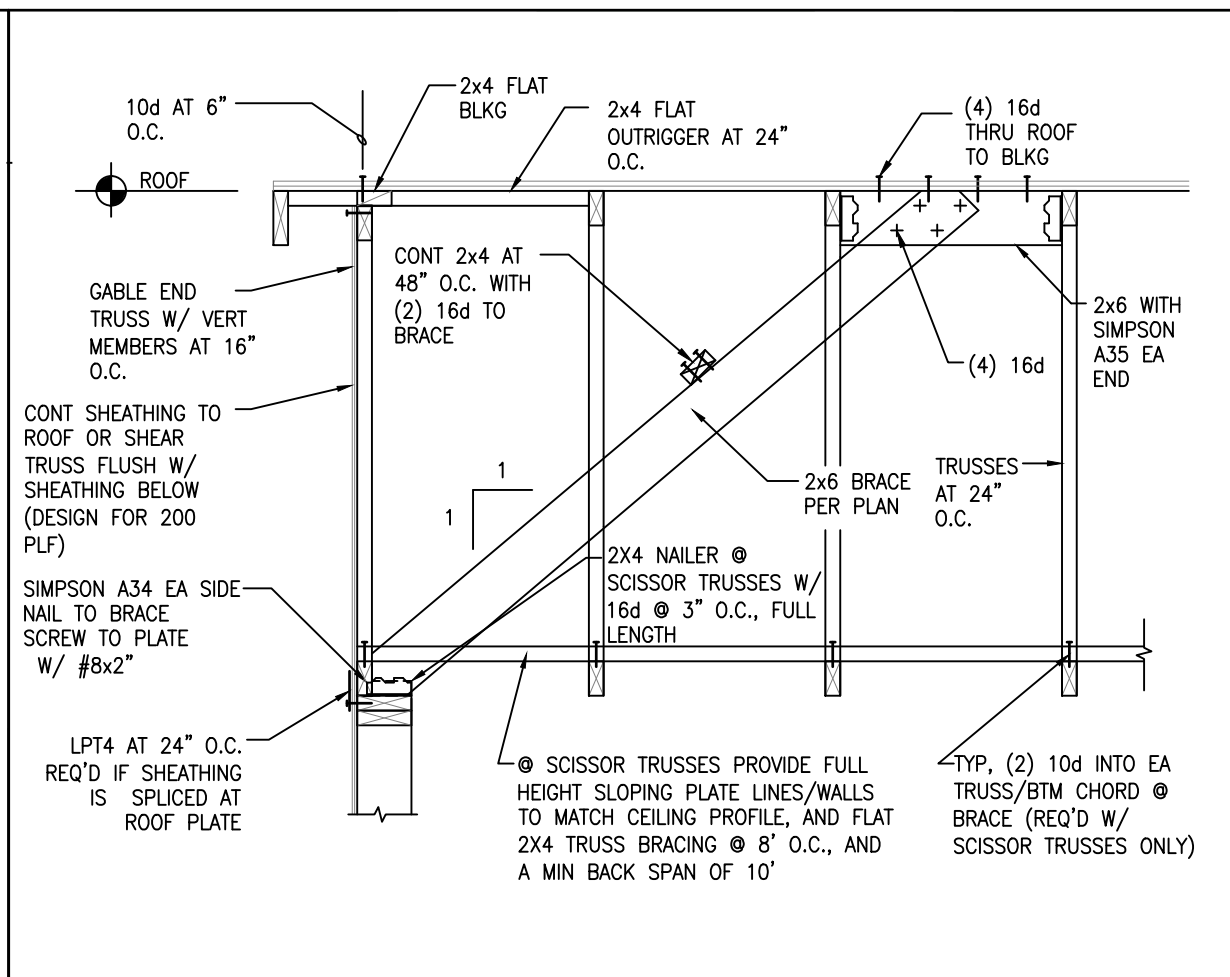

5 GABLE END FRAMING (FLAT OR SCISSOR)

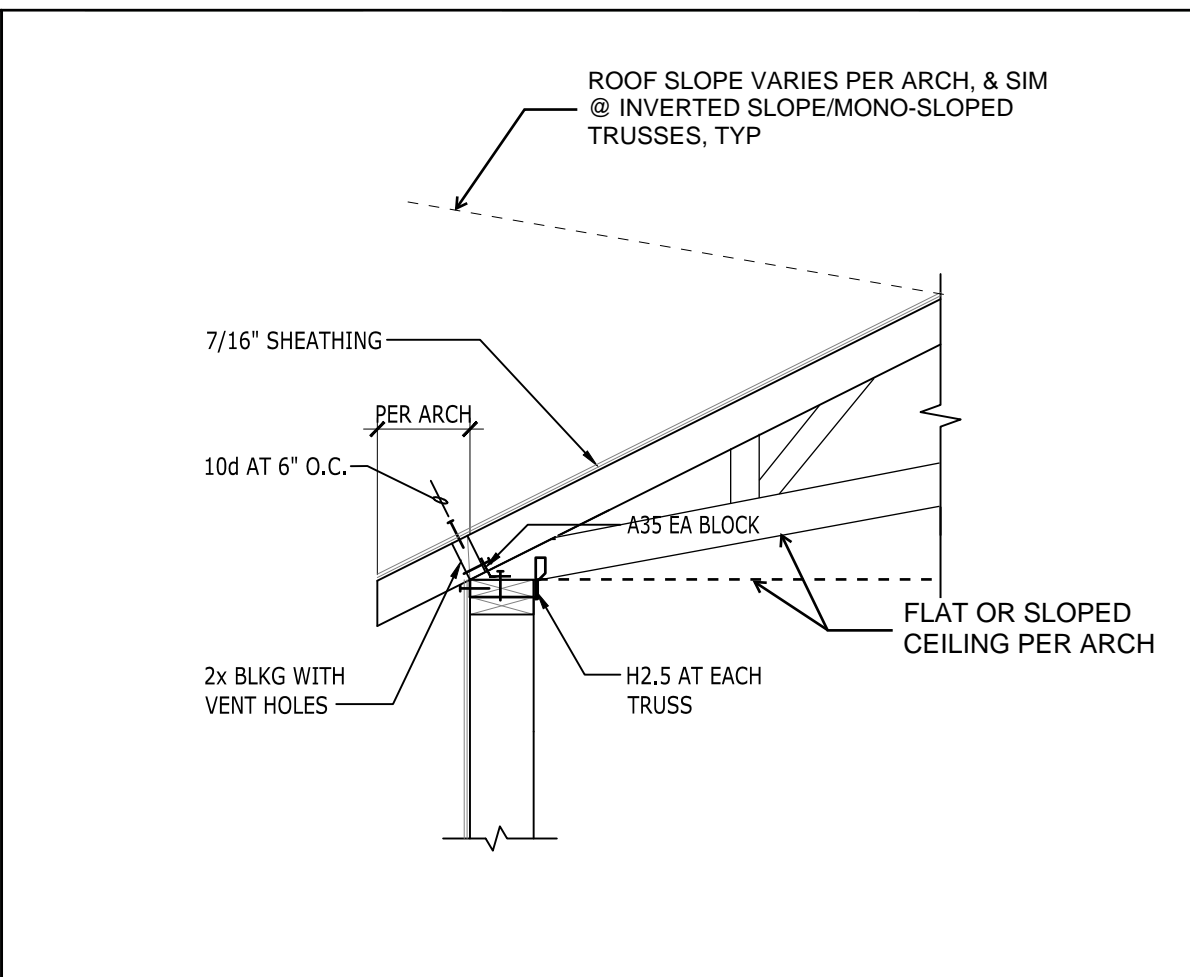

4 HIP ROOF FRAMING (FLAT OR SCISSOR)

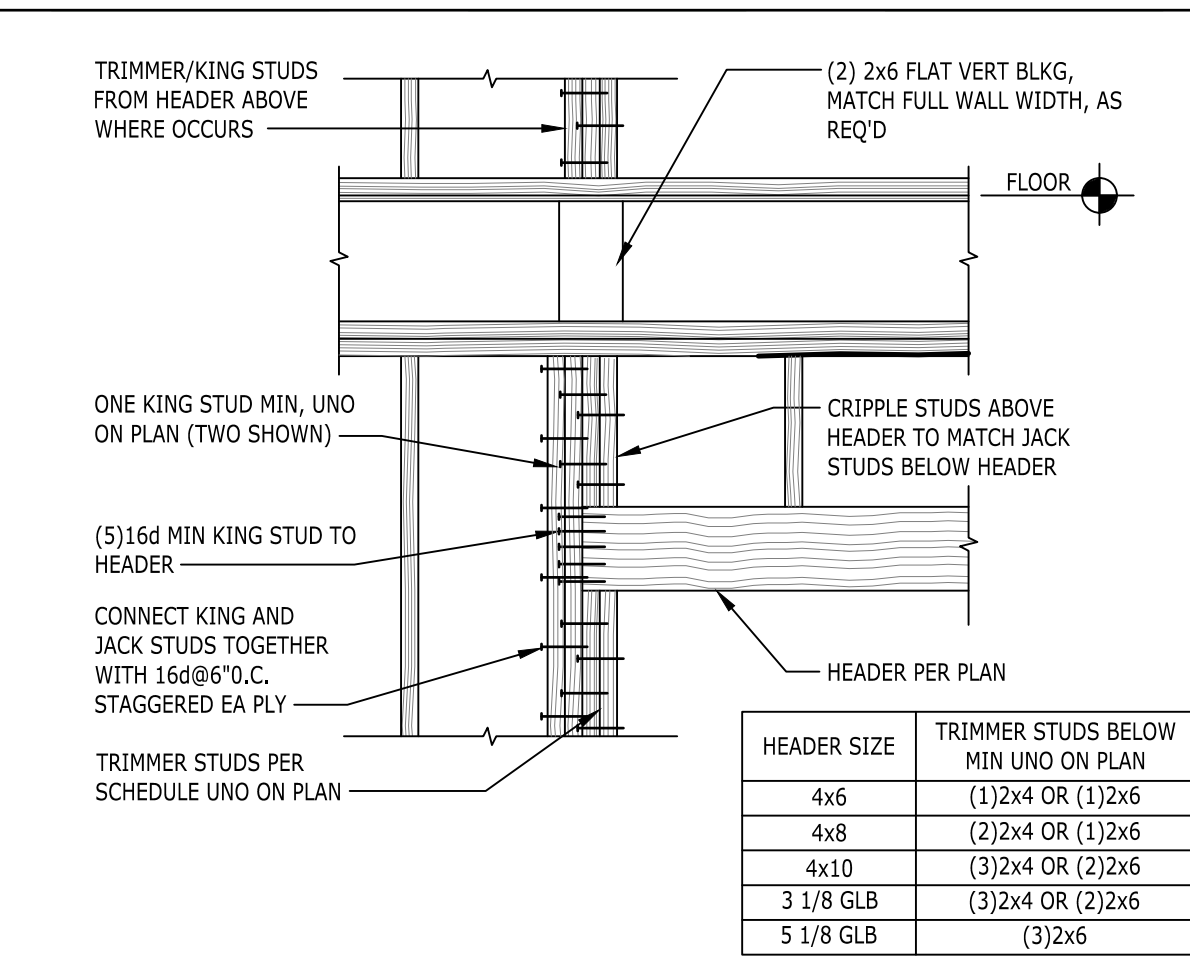

3 TYPICAL HEADER FRAMING

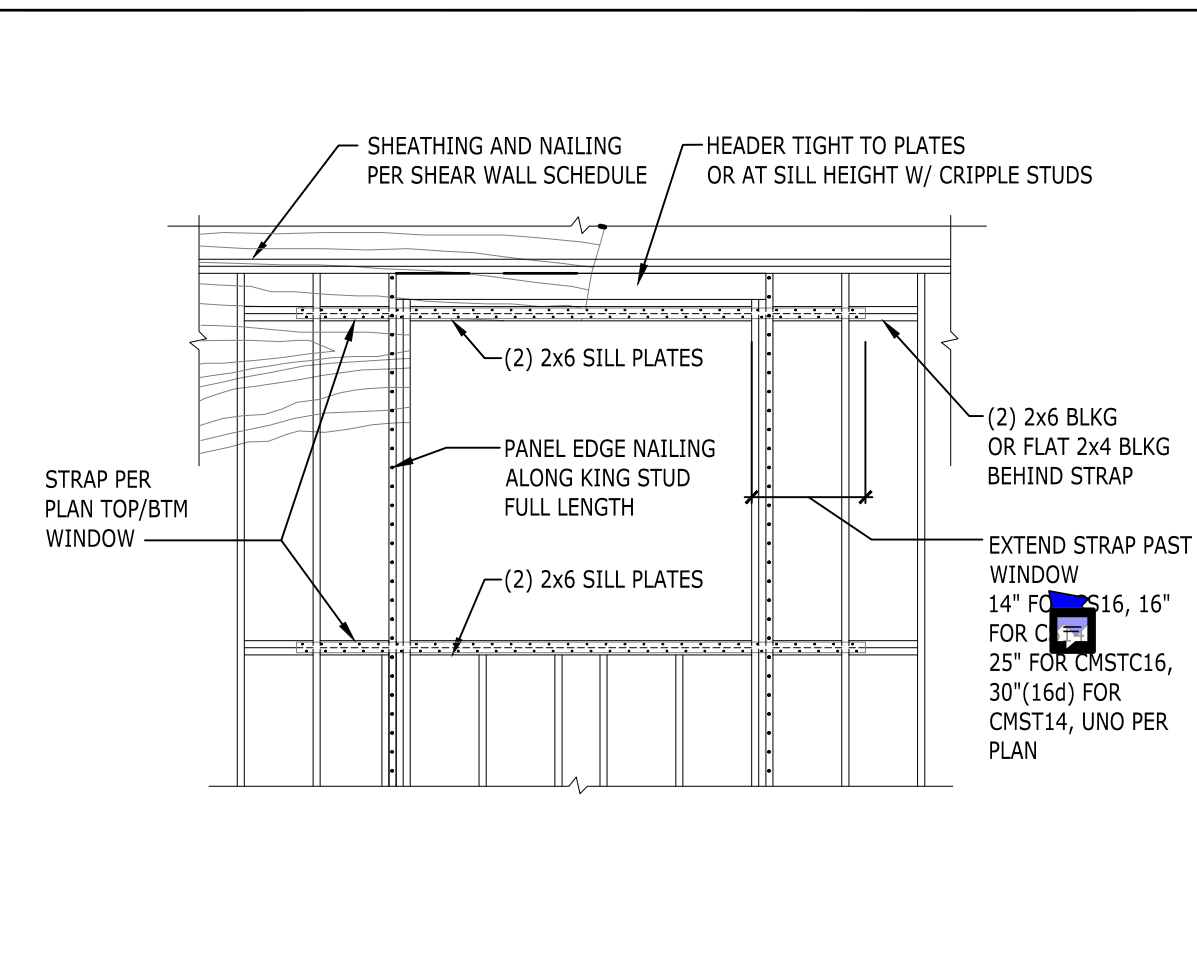

2 STRAPS AROUND WINDOWS

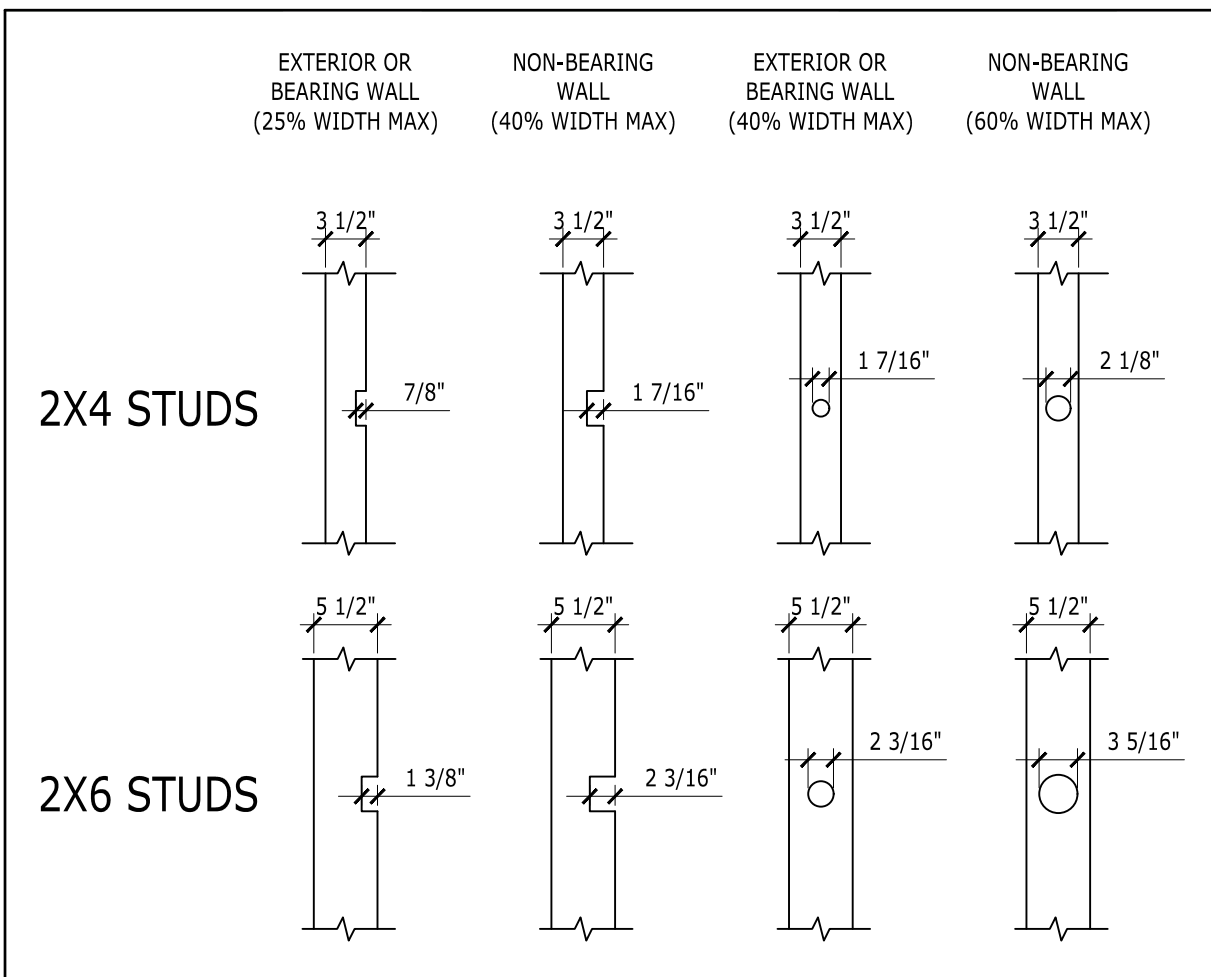

1 ALLOWABLE STUD NOTCHING AND BORING



9 TYPICAL TRUSS BLOCKING

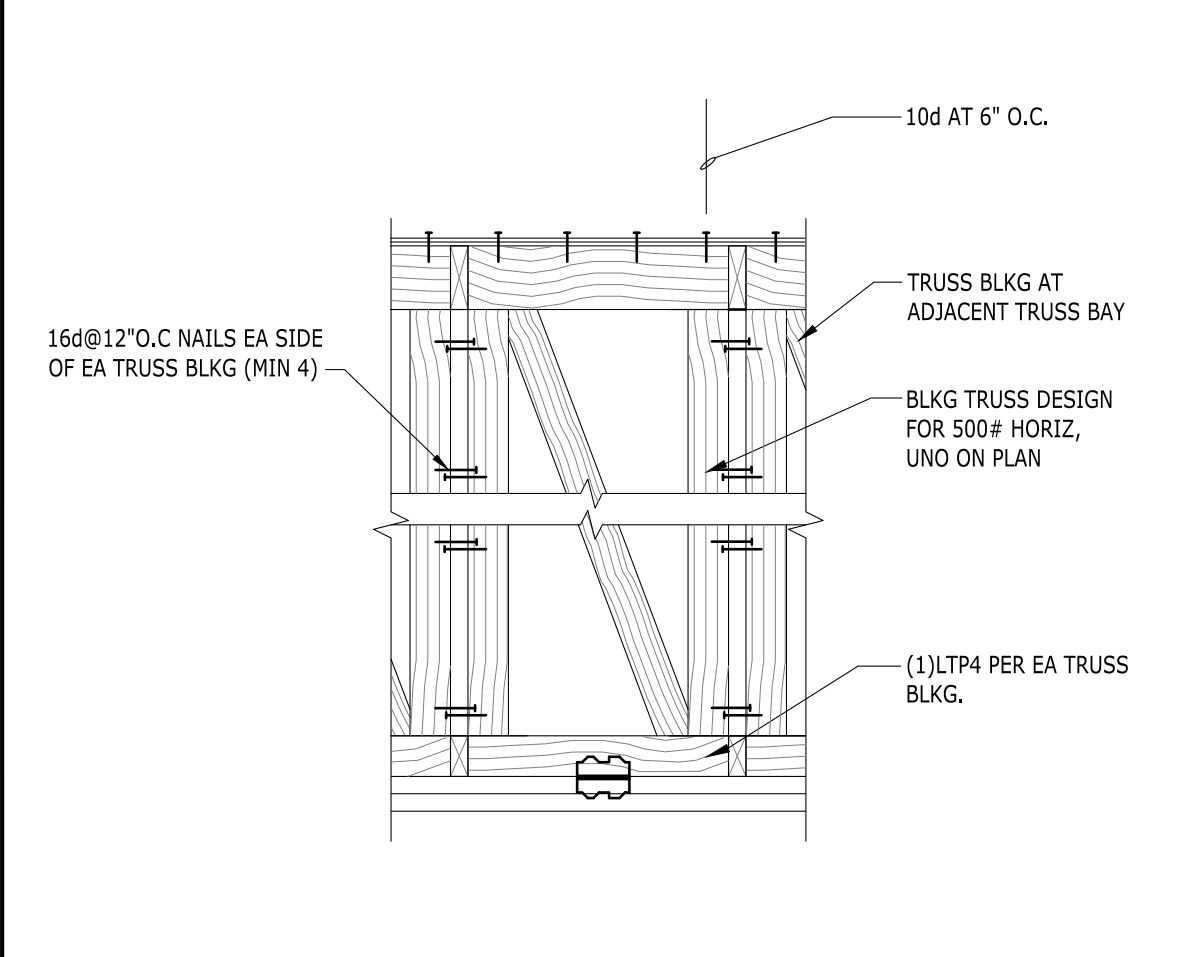

8 RAFTER DETAIL (GABLE)

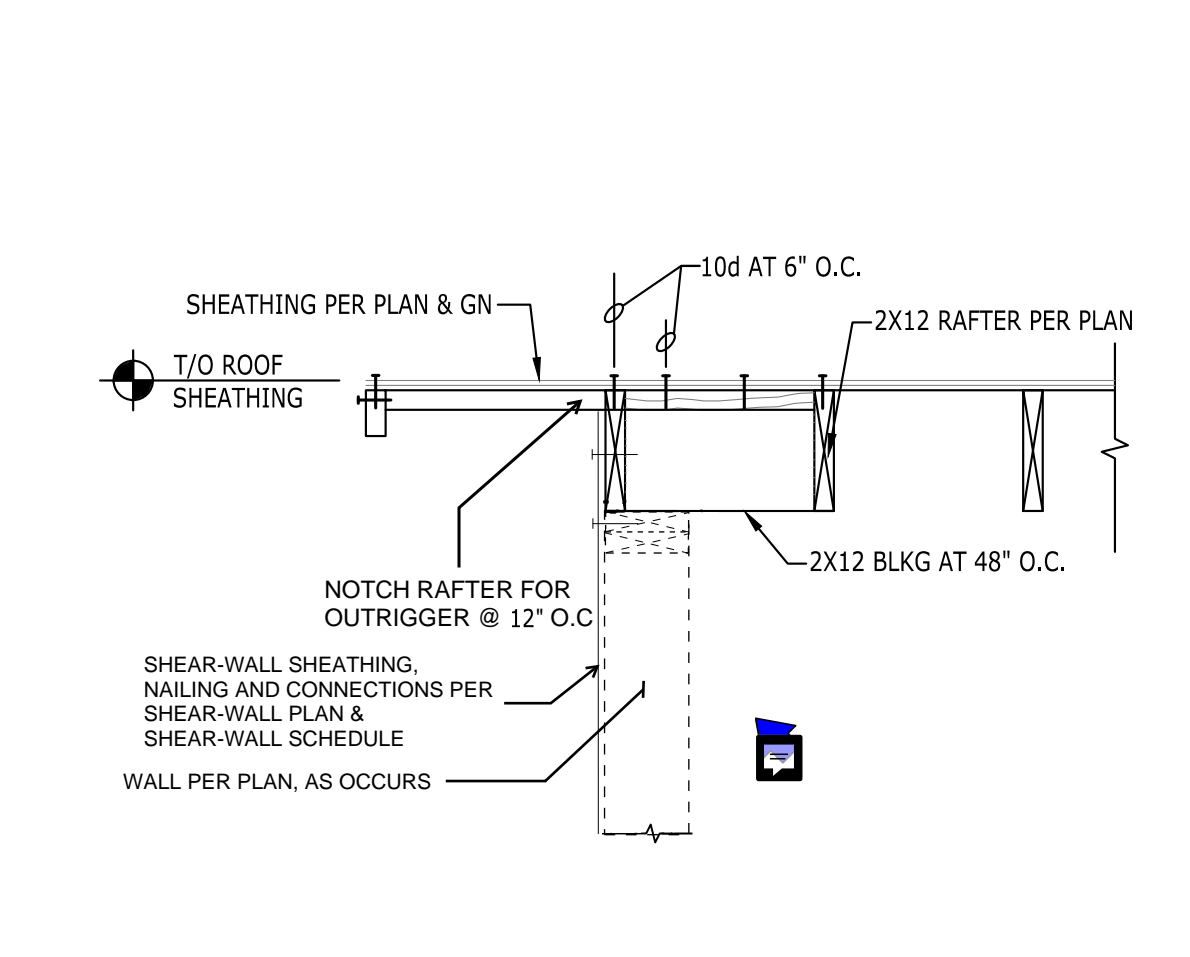

7 RAFTER DETAIL (HIP)

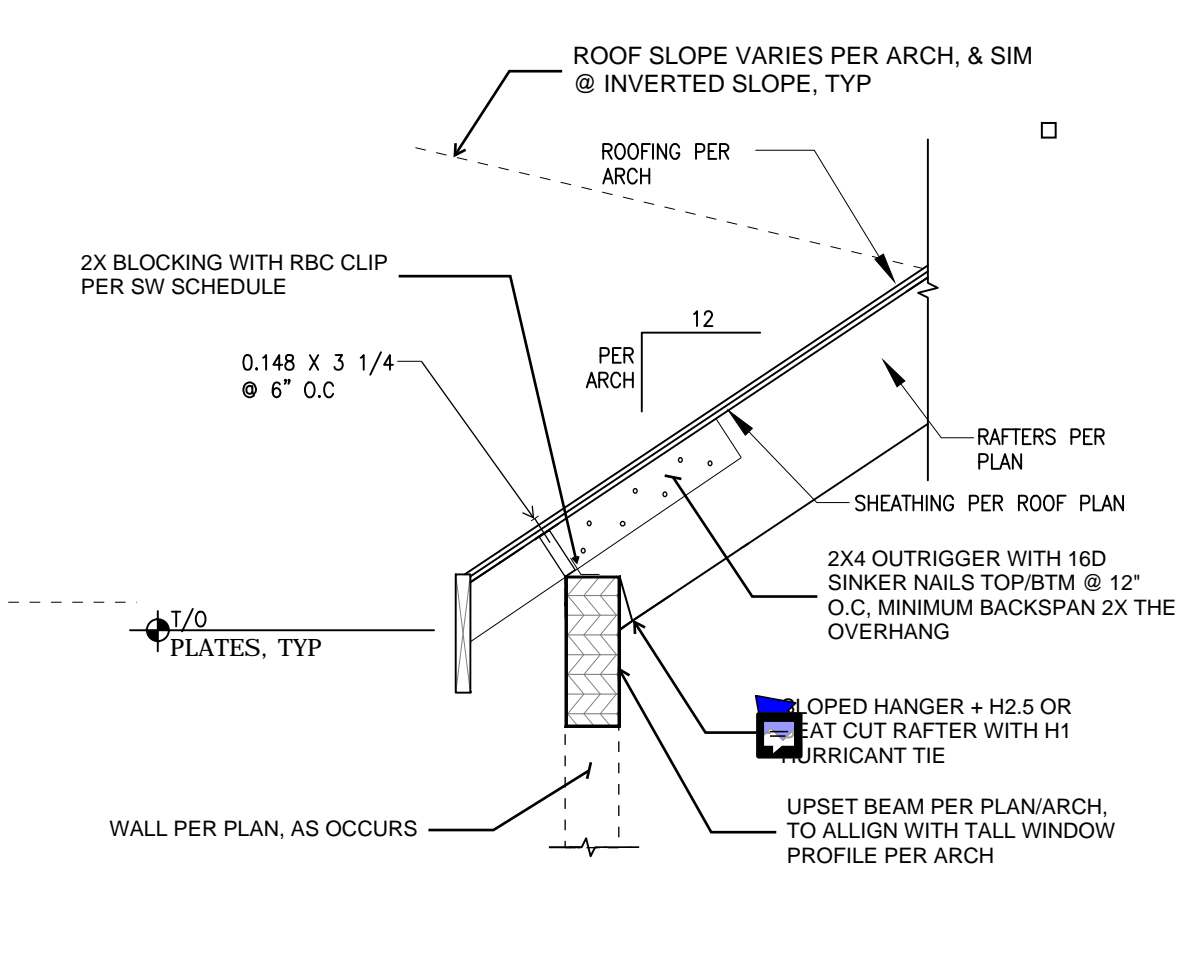

6 ROOF OVERFRAMING

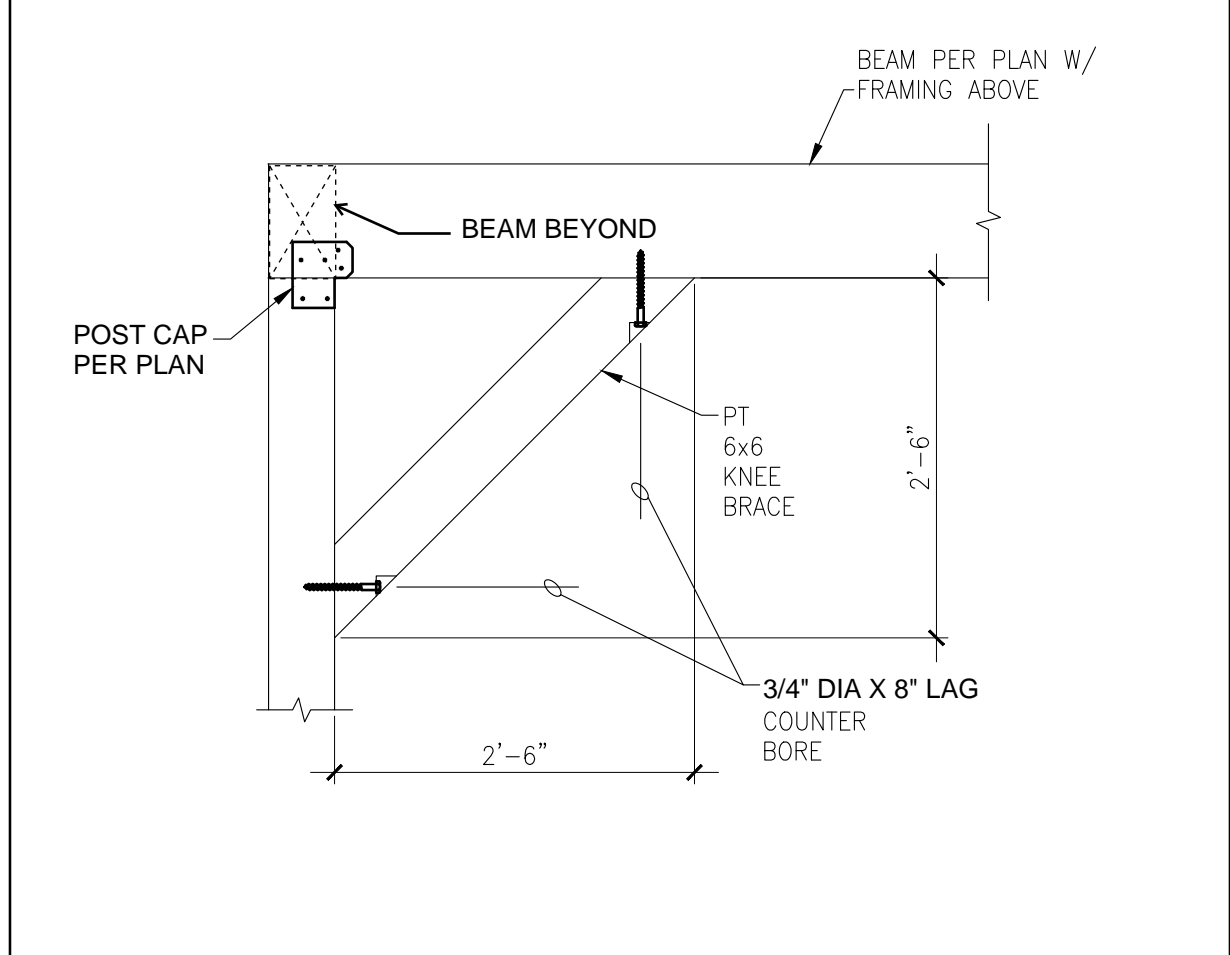

15 CORNER BRACE AT DECK

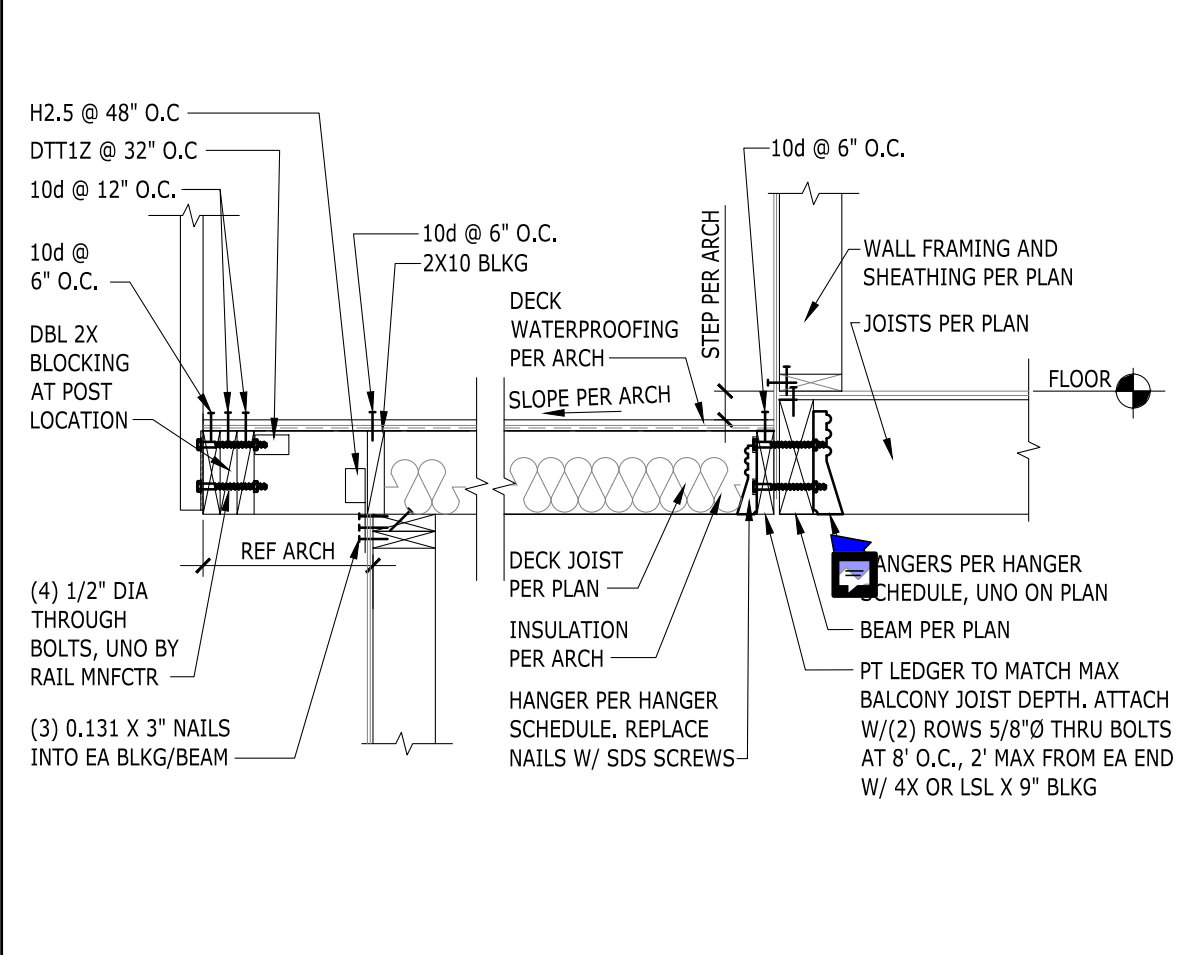

14 DECK FRAMING

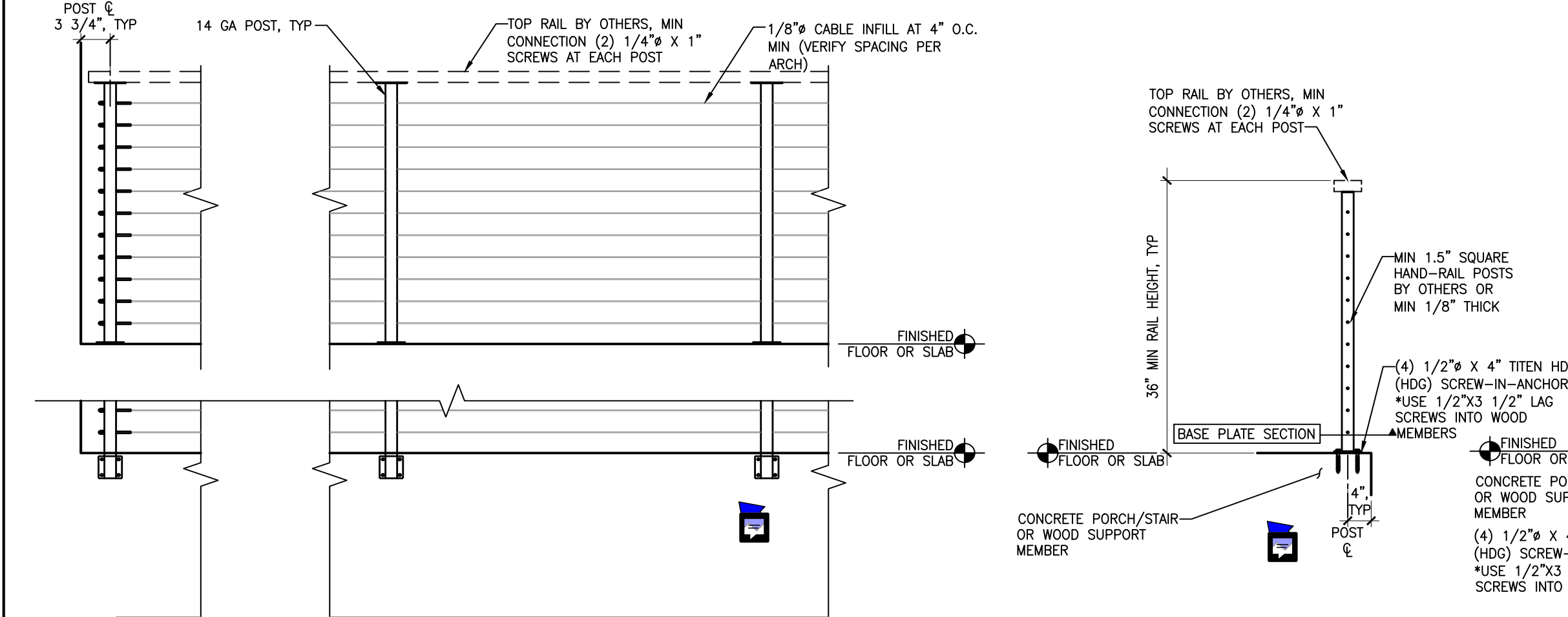
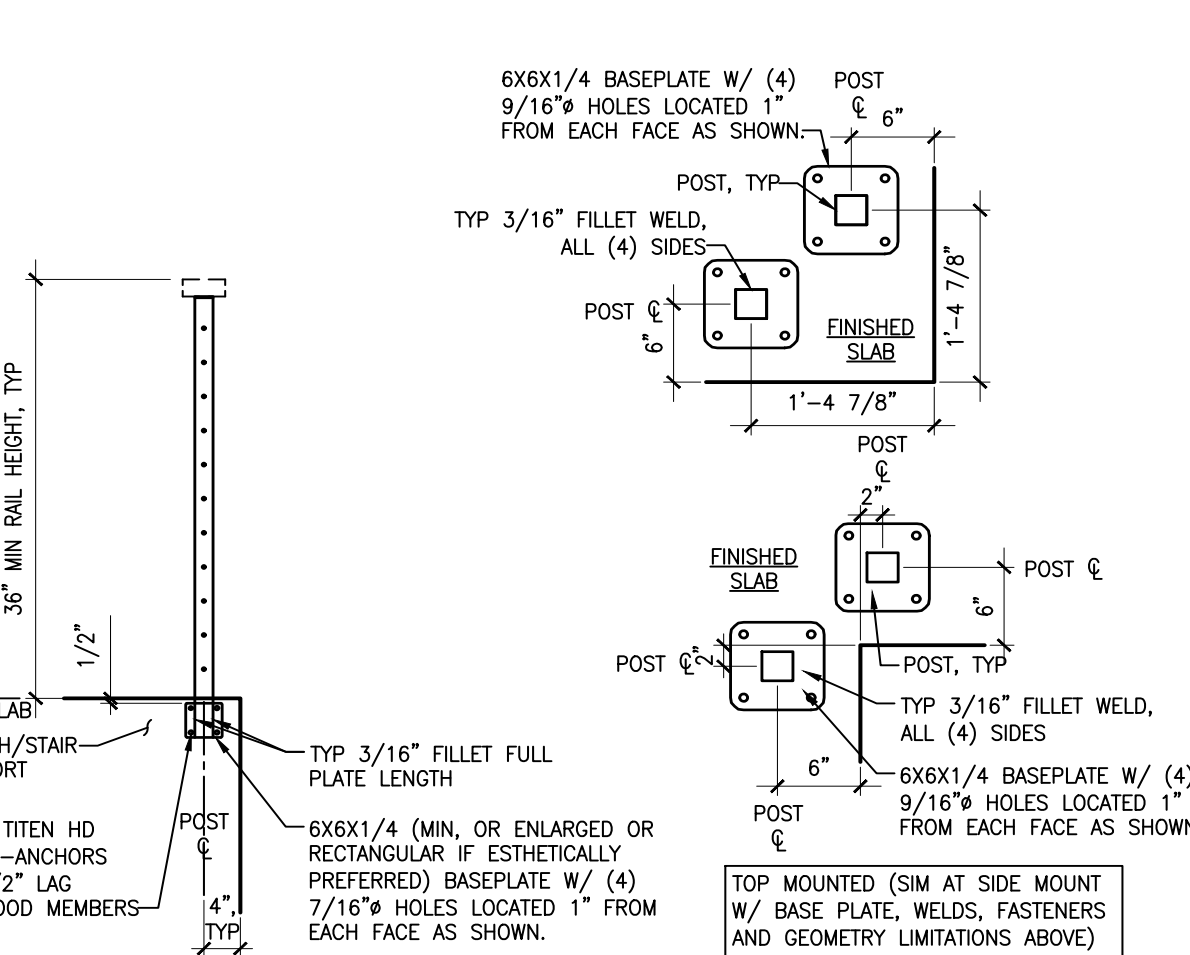

11 TYP END POST ELEVATION TYP INTERMEDIATE POST ELEVATION TOP MOUNTED RAILING SECTION SIDE MOUNTED OPTION BASE PLATE SECTION

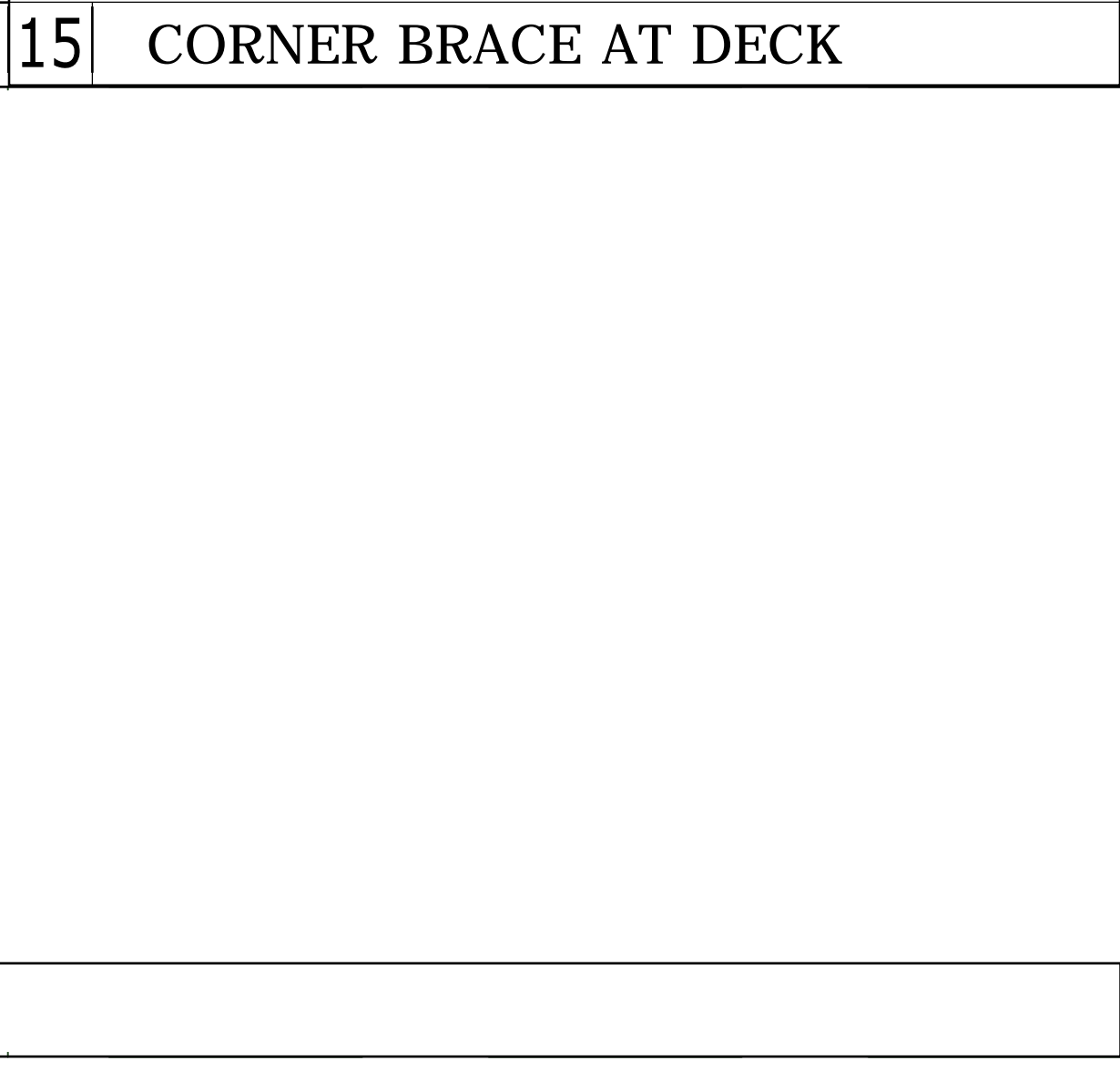

17 SHEAR TRANSFER AT EXTERIOR WALL

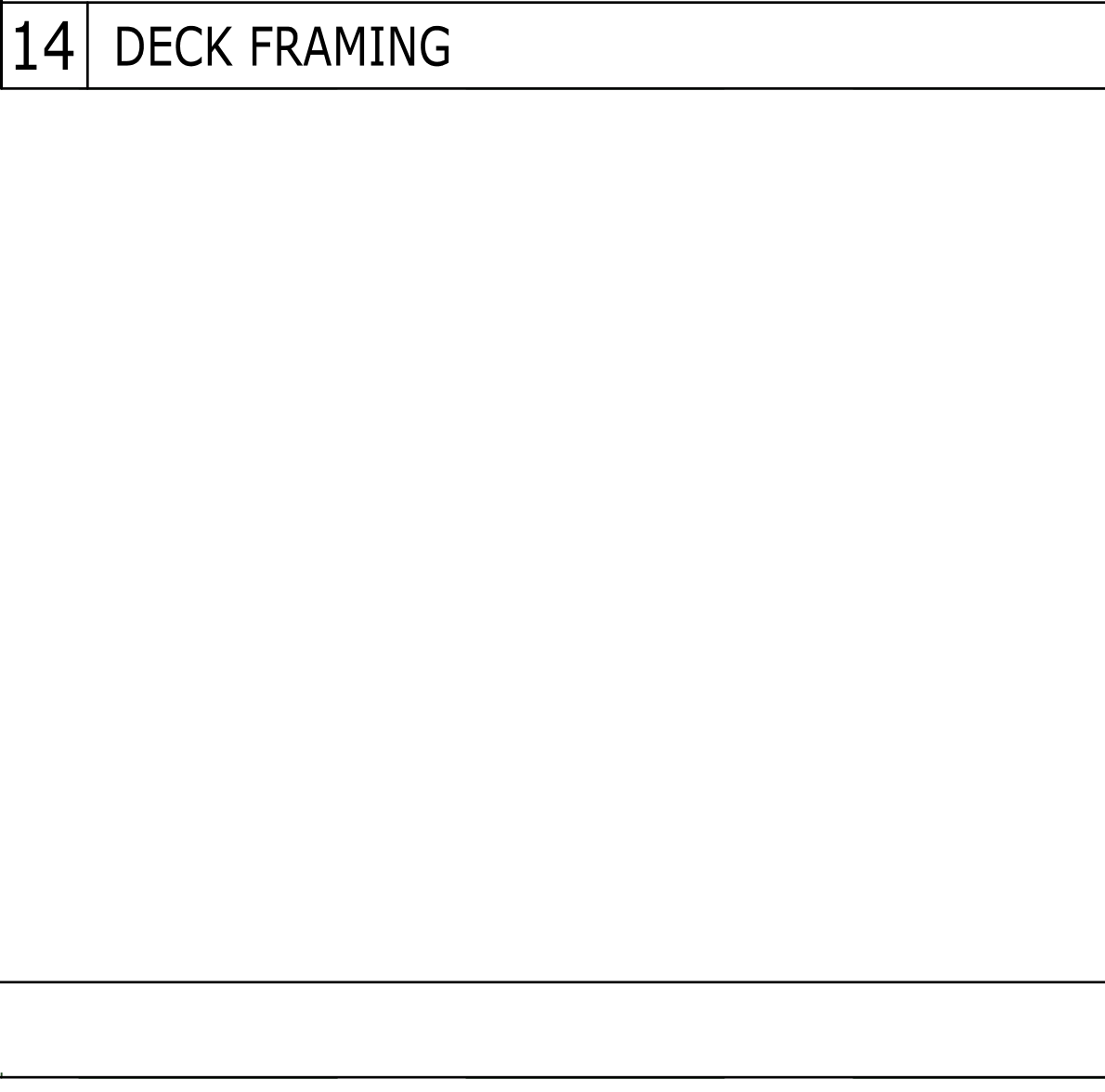

18 SHEAR TRANSFER AT EXTERIOR WALL

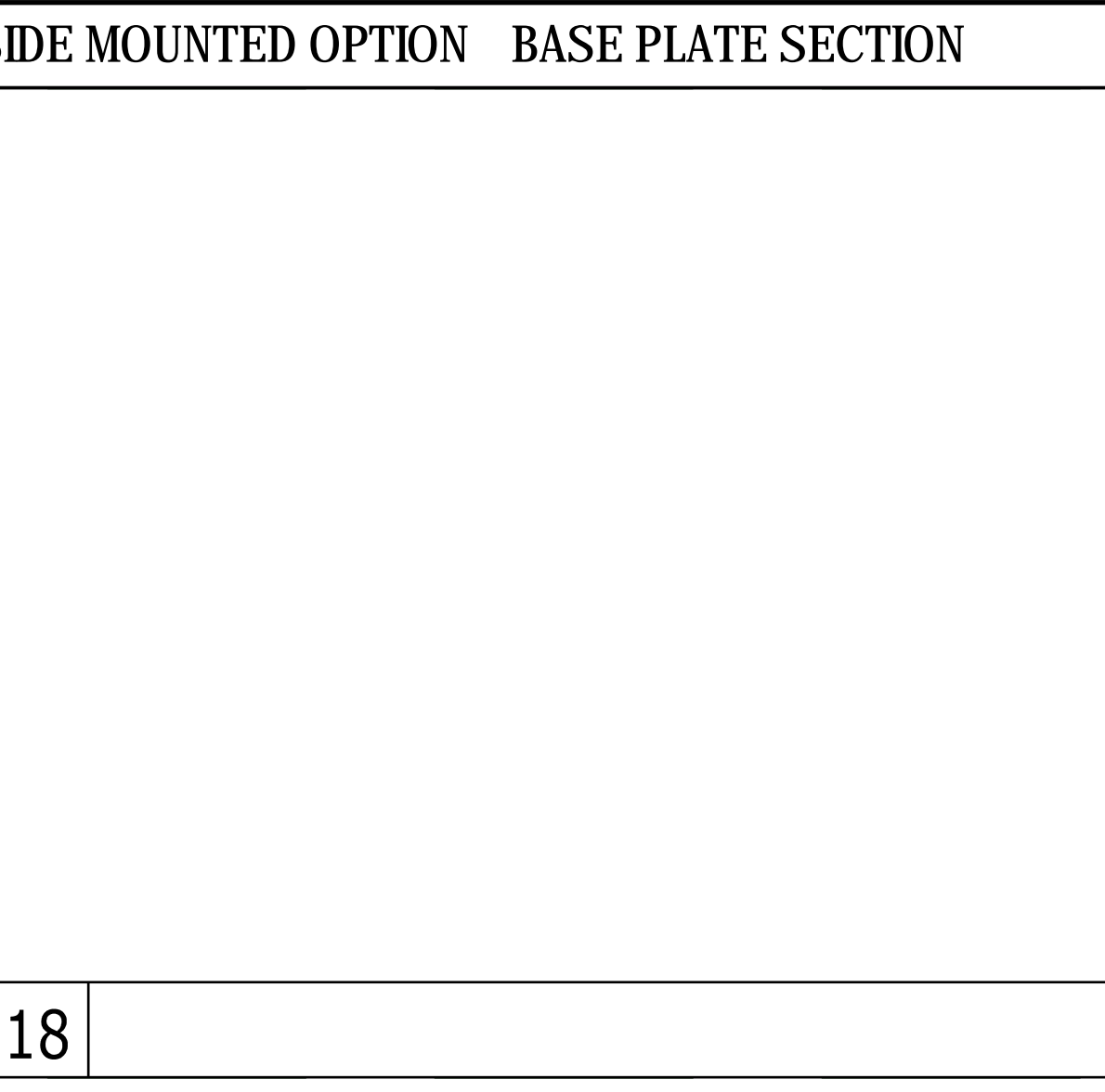

16 SHEAR TRANSFER AT EXTERIOR WALL

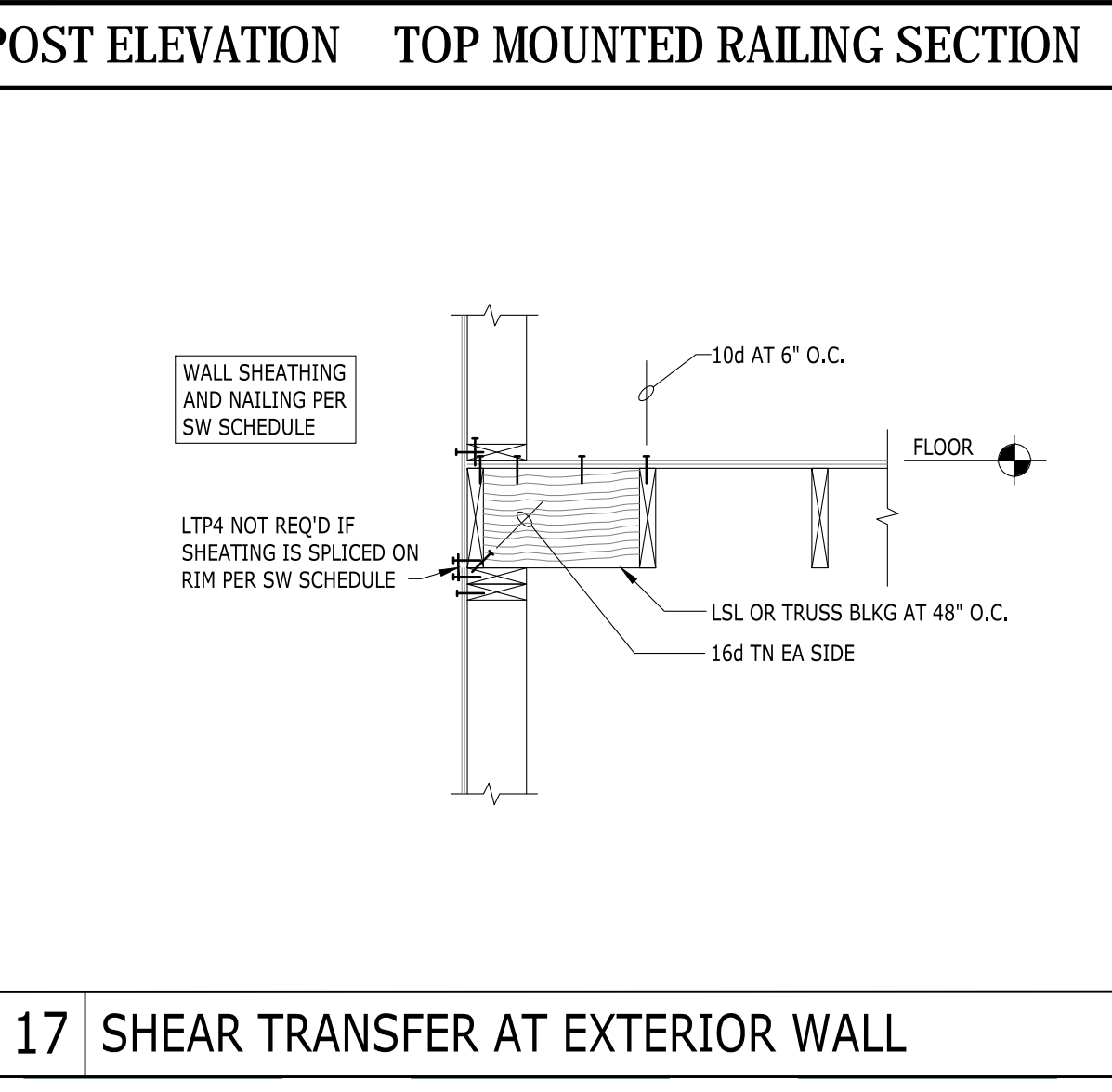

17 SHEAR TRANSFER AT EXTERIOR WALL

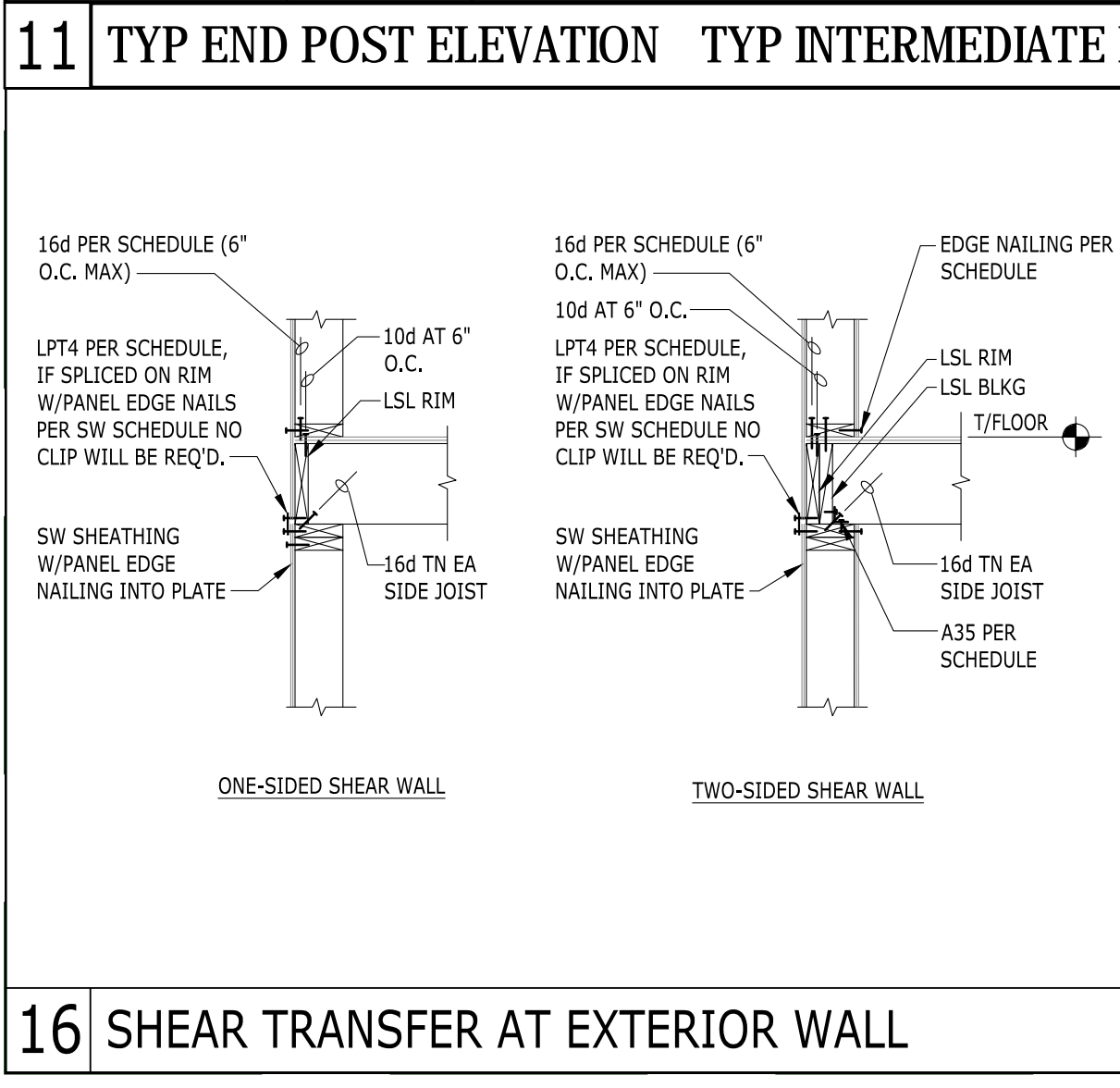

16 SHEAR TRANSFER AT EXTERIOR WALL