

Construction Stormwater General Permit (CSWGP)

Stormwater Pollution Prevention Plan (SWPPP)

for
Koneru SFR

Prepared for:
**Department of Ecology
Northwest Regional Office
3190 160th Avenue SE
Bellevue, WA 98008-5452
425-649-7000**

Permittee / Owner	Developer	Operator / Contractor
Dheeraj Koneru	TBD	TBD

6610 East Mercer Way

Mercer Island, WA 98040

Certified Erosion and Sediment Control Lead (CESCL)

Name	Organization	Contact Phone Number
TBD	TBD	TBD

SWPPP Prepared By

Name	Organization	Contact Phone Number
John Anderson	PACE Engineers	425-827-2014

SWPPP Preparation Date

December 22, 2021

Project Construction Dates

Activity / Phase	Start Date	End Date
Grading Permit	5/01/2022	8/01/2022

List of Acronyms and Abbreviations

Acronym / Abbreviation	Explanation
303(d)	Section of the Clean Water Act pertaining to Impaired Waterbodies
BFO	Bellingham Field Office of the Department of Ecology
BMP(s)	Best Management Practice(s)
CESCL	Certified Erosion and Sediment Control Lead
CO₂	Carbon Dioxide
CRO	Central Regional Office of the Department of Ecology
CSWGP	Construction Stormwater General Permit
CWA	Clean Water Act
DMR	Discharge Monitoring Report
DO	Dissolved Oxygen
Ecology	Washington State Department of Ecology
EPA	United States Environmental Protection Agency
ERO	Eastern Regional Office of the Department of Ecology
ERTS	Environmental Report Tracking System
ESC	Erosion and Sediment Control
GULD	General Use Level Designation
NPDES	National Pollutant Discharge Elimination System
NTU	Nephelometric Turbidity Units
NWRO	Northwest Regional Office of the Department of Ecology
pH	Power of Hydrogen
RCW	Revised Code of Washington
SPCC	Spill Prevention, Control, and Countermeasure
su	Standard Units
SWMMEW	Stormwater Management Manual for Eastern Washington
SWMMWW	Stormwater Management Manual for Western Washington
SWPPP	Stormwater Pollution Prevention Plan
TESC	Temporary Erosion and Sediment Control
SWRO	Southwest Regional Office of the Department of Ecology
TMDL	Total Maximum Daily Load
VFO	Vancouver Field Office of the Department of Ecology
WAC	Washington Administrative Code
WSDOT	Washington Department of Transportation
WWHM	Western Washington Hydrology Model

Project Information (1.0)

Project/Site Name: Koneru SFR
Street/Location: 6610 East Mercer Way
City: Mercer Island State: WA Zip code: 98040
Subdivision: N/A
Receiving waterbody: Sammamish River

Existing Conditions (1.1)

Total acreage (including support activities such as off-site equipment staging yards, material storage areas, borrow areas).

Total acreage: 1.15
Disturbed acreage: 1.10
Existing structures: N/A
Landscape topography: Slopes ranging from 3% to 5.5%
Drainage patterns: 100% of on-site stormwater flows east to Lake Washington. Stormwater will follow the same flow pattern after the site has been developed.
Existing Vegetation: Maintained grass lawn, landscaping, and brush
Critical Areas (wetlands, streams, high erosion risk, steep or difficult to stabilize slopes):
Lake Washington

List of known impairments for 303(d) listed or Total Maximum Daily Load (TMDL) for the receiving waterbody: N/A

Table 1 includes a list of suspected and/or known contaminants associated with the construction activity.

Table 1 – Summary of Site Pollutant Constituents

Constituent (Pollutant)	Location	Depth	Concentration
N/A	N/A	N/A	N/A

Proposed Construction Activities (1.2)

Description of site development (example: subdivision):

Construction of single-family residence, associated driveway, associated utilities.

Description of construction activities (example: site preparation, demolition, excavation):

Construction activities will include site preparation (TESC measures), installing utilities, construction of driveway and single-family residence.

Description of site drainage including flow from and onto adjacent properties. Must be consistent with Site Map in Appendix A:

The site is currently developed with a storm system consisting of a catch basin within the existing driveway that conveys surface water runoff and roof runoff east where it is discharged directly to Lake Washington. The proposed project will maintain the existing drainage flowpath in the developed condition.

Description of final stabilization (example: extent of revegetation, paving, landscaping):

Final stabilization will include paving and landscaping.

Contaminated Site Information:

Proposed activities regarding contaminated soils or groundwater (example: on-site treatment system, authorized sanitary sewer discharge):

N/A

Construction Stormwater Best Management Practices (BMPs) (2.0)

The SWPPP is a living document reflecting current conditions and changes throughout the life of the project. These changes may be informal (i.e. hand-written notes and deletions). Update the SWPPP when the CESCL has noted a deficiency in BMPs or deviation from original design.

The 13 Elements (2.1)

Element 1: Preserve Vegetation / Mark Clearing Limits (2.1.1)

Construction limits will clearly be marked prior to construction to protect adjacent properties and reduce the area of exposed soil. Any trees to be preserved will be marked clearly on the plans and in the field. Natural vegetation and native topsoil will be retained in an undisturbed state to the maximum extent possible. The relevant BMPs to preserving vegetation and marking clearing limits are listed in this section.

List and describe BMPs:

- BMP C101: Preserve Natural Vegetation
- BMP C233: Silt Fence

Installation Schedules: Prior to any construction, the fencing shall be installed at all necessary locations. Clearing limits are shown on the TESC plan and delineated with BMP C233.

Inspection and Maintenance plan: Any fence damage or visibility reduction shall be repaired or replaced immediately.

Responsible Staff: CESCL

Element 2: Establish Construction Access (2.1.2)

Construction activities occurring on unpaved areas shall be minimized, but an access point shall be stabilized prior to construction to reduce the amount of sediment transported onto paved roads by vehicles or equipment. All wastewater coming from the site during construction will be controlled. The BMPs related to establishing construction access for this project will be listed in this section.

List and describe BMPs:

- BMP C105: Stabilized Construction Entrance

The site will utilize the existing driveway as a construction entrance.

Installation Schedules: The construction entrance currently exists.

Inspection and Maintenance plan: Inspection and maintenance standards per BMP C105 shall be followed. The construction entrance shall be inspected at least once per day to ensure no sediment is being tracked onto the public roadway or adjacent private driveways.

Any sediment that has been tracked onto the pavement shall be removed by shoveling or street sweeping, and not by washing down the street. Do not use any sweeper that will create dust and throw sediment into the storm system. Transport the collected sediment to a controlled sediment disposal area that has been established on site.

Responsible Staff: CESCL

Element 3: Control Flow Rates (2.1.3)

Will you construct stormwater retention and/or detention facilities?

Yes No

Will you use permanent infiltration ponds or other low impact development (example: rain gardens, bio-retention, porous pavement) to control flow during construction?

Yes No

List and describe BMPs:

- N/A

Installation Schedules: N/A

Inspection and Maintenance plan: N/A

Responsible Staff: CESCL

Element 4: Install Sediment Controls (2.1.4)

List and describe BMPs:

- BMP C233: Silt Fence

Installation Schedules: The silt fence shall be installed before construction begins and remain in place until the site is stabilized. Silt fence shall be installed as shown on the TESC plan.

Inspection and Maintenance plan: If there is any sign of failure or damage to the silt fence, it should be repaired immediately.

Responsible Staff: CESCL

Element 5: Stabilize Soils (2.1.5)

West of the Cascade Mountains Crest

Season	Dates	Number of Days Soils Can be Left Exposed
During the Dry Season	May 1 – September 30	7 days
During the Wet Season	October 1 – April 30	2 days

Soils must be stabilized at the end of the shift before a holiday or weekend if needed based on the weather forecast.

Anticipated project dates: Start date: May 1, 2022 End date: August 1, 2022

Will you construct during the wet season?

No

List and describe BMPs:

- BMP C120: Temporary and Permanent Seeding
- BMP C121: Mulching
- BMP C123: Plastic Covering
- BMP C126: Topsoiling
- BMP C140: Dust Control

Installation Schedules: When at any point soil is exposed, any of the BMPs listed above shall be utilized at the contractor's discretion. Soil stockpiles will be temporarily covered by plastic sheeting. All stockpiled soils shall be stabilized from erosion, and where possible, be located away from storm drain outlets.

Inspection and Maintenance plan: Soil stockpiles shall be inspected at a minimum of once a week.

Responsible Staff: CESCL

Element 6: Protect Slopes (2.1.6)

Will steep slopes be present at the site during construction?

No Yes

There are no steep slopes located on site.

List and describe BMPs:

- BMP C120: Temporary and Permanent Seeding
- BMP C123: Plastic Covering

Installation Schedules: To the contractor's discretion, the BMPs listed above shall be used to protect any steep slopes that may be created during construction though none are anticipated.

Inspection and Maintenance plan: Inspection and maintenance standards, as listed in the BMPs, shall be followed throughout construction. If the slope's cover is damaged or not performing as it should, repairs or replacement shall happen immediately.

Responsible Staff: CESCL

Element 7: Protect Drain Inlets (2.1.7)

List and describe BMPs:

- BMP C220: Inlet Protection

Installation Schedules: Inlets will be inspected weekly at a minimum and daily during storm events.

Inspection and Maintenance plan: Inlet protection devices will be cleaned (or removed and replaced), when sediment has filled the device by one third (1/3) or as specified by the manufacturer.

Responsible Staff: CESCL

Element 8: Stabilize Channels and Outlets (2.1.8)

Provide stabilization, including armoring material, adequate to prevent erosion of outlets, adjacent stream banks, slopes, and downstream reaches, will be installed at the outlets of all conveyance systems.

List and describe BMPs:

- BMP C209: Outlet Protection
- BMP C202: Riprap Channel Lining

Installation Schedules: Outlet protection will be installed prior to final placement of outlet storm pipe to Lake Washington. Riprap outfall protection is proposed for installation at the pipe outlet to Lake Washington for the permanent condition.

Inspection and Maintenance plan:

- Inspect and repair as needed
- Add rock as needed to maintain intended function
- Clean energy dissipator if sediment builds up

Responsible Staff: CESCL

Element 9: Control Pollutants (2.1.9)

The following pollutants are anticipated to be present on-site:

Table 2 – Pollutants

Pollutant (and source, if applicable)
Fuel – contaminated soil if a vehicle is found to be leaking

List and describe BMPs:

- BMP C150: Materials on Hand
- BMP C153: Material Delivery, Storage, and Containment

Installation Schedules: The BMPs listed above shall be implemented as needed to prevent the contamination of stormwater.

Inspection and Maintenance plan:

- Waste materials and demolition debris shall be handled in a manner that does not cause any contamination of stormwater.
- Provide cover, containment, and protection from vandalism for all chemicals, liquid products, petroleum products, and other materials that have the potential to pose a threat to human health and the environment. Secondary containment, an impervious structure capable of containing 110% of the volume of the largest tank, should be provided for all tanks holding pollutants. Double-walled tanks do not require secondary containment. If stormwater becomes polluted within the containment structure, it must be managed appropriately based upon the type of pollutant.
- When conducting maintenance or repairs under heavy equipment and vehicles, drip pans or other spill prevention control measure shall be used. This includes oil changes, hydraulic system drain down, solvent and de-greasing cleaning operations, fuel tank drain down and removal, and other activities which may result in discharge or spillage of pollutants to the ground or into stormwater runoff. Contaminated surfaces shall be cleaned immediately following any incident.
- Wheel wash or tire bath wastewater shall be discharged to a separate onsite treatment system that prevents any discharge into the surface water. These systems include closed-loop recirculation, upland applications, or sanitary sewer.
- Agricultural chemicals, such as pesticides or fertilizers, should only be applied when necessary, and in a manner that will not result in any chemicals entering the stormwater runoff. Follow manufacturers' recommendations for application rates and procedures.

- Use BMPs to prevent or treat contamination of stormwater runoff by pH modifying sources such as bulk cement, cement kiln dust, fly ash, new concrete washing and curing waters, waste streams generated from concrete grinding and sawing, exposed aggregate processes, and concrete pumping and mixer washout waters.
- Written approval from the Department of Ecology is required prior to using chemical treatment other than CO2 or dry ice to adjust pH.
- Clean contaminated surfaces immediately following any discharge or spill incident.

Responsible Staff: CESCL

Will maintenance, fueling, and/or repair of heavy equipment and vehicles occur on-site?

No

List and describe BMPs: N/A

Installation Schedules: N/A

Inspection and Maintenance plan: N/A

Responsible Staff: N/A

Will wheel wash or tire bath system BMPs be used during construction?

No

List and describe BMPs: N/A

Installation Schedules: N/A

Inspection and Maintenance plan: N/A

Responsible Staff: N/A

Will pH-modifying sources be present on-site?

No

Table 3 – pH-Modifying Sources

	None
	Bulk cement
	Cement kiln dust

	Fly ash
	Other cementitious materials
	New concrete washing or curing waters
	Waste streams generated from concrete grinding and sawing
	Exposed aggregate processes
	Dewatering concrete vaults
	Concrete pumping and mixer washout waters
	Recycled concrete
	Other (i.e. calcium lignosulfate) [please describe]

List and describe BMPs:

- N/A

Installation Schedules: N/A

Inspection and Maintenance plan: N/A

Responsible Staff: CESCL

<p>Concrete trucks must not be washed out onto the ground, or into storm drains, open ditches, streets, or streams. Excess concrete must not be dumped on-site, except in designated concrete washout areas with appropriate BMPs installed.</p>
--

Element 10: Control Dewatering (2.1.10)

Dewatering is not anticipated for this site.

Table 4 – Dewatering BMPs

	Infiltration
	Transport off-site in a vehicle (vacuum truck for legal disposal)
	Ecology-approved on-site chemical treatment or other suitable treatment technologies
	Sanitary or combined sewer discharge with local sewer district approval (last resort)
	Use of sedimentation bag with discharge to ditch or swale (small volumes of localized dewatering)

List and describe BMPs:

- N/A

Installation Schedules: N/A

Inspection and Maintenance plan: N/A

Responsible Staff: CESCL

Element 11: Maintain BMPs (2.1.11)

All temporary and permanent Erosion and Sediment Control (ESC) BMPs shall be maintained and repaired as needed to ensure continued performance of their intended function.

Maintenance and repair shall be conducted in accordance with each particular BMP specification (see *Volume II of the SWMMWW* or *Chapter 7 of the SWMMEW*).

Visual monitoring of all BMPs installed at the site will be conducted at least once every calendar week and within 24 hours of any stormwater or non-stormwater discharge from the site. If the site becomes inactive and is temporarily stabilized, the inspection frequency may be reduced to once every calendar month.

All temporary ESC BMPs shall be removed within 30 days after final site stabilization is achieved or after the temporary BMPs are no longer needed.

Trapped sediment shall be stabilized on-site or removed. Disturbed soil resulting from removal of either BMPs or vegetation shall be permanently stabilized.

Additionally, protection must be provided for all BMPs installed for the permanent control of stormwater from sediment and compaction. BMPs that are to remain in place following completion of construction shall be examined and restored to full operating condition. If sediment enters these BMPs during construction, the sediment shall be removed, and the facility shall be returned to conditions specified in the construction documents.

Element 12: Manage the Project (2.1.12)

The project will be managed based on the following principles:

- Projects will be phased to the maximum extent practicable and seasonal work limitations will be taken into account.
- Inspection and monitoring:
 - Inspection, maintenance and repair of all BMPs will occur as needed to ensure performance of their intended function.
 - Site inspections and monitoring will be conducted in accordance with Special Condition S4 of the CSWGP. Sampling locations are indicated on the [Site Map](#). Sampling station(s) are located in accordance with applicable requirements of the CSWGP.
- Maintain an updated SWPPP.
 - The SWPPP will be updated, maintained, and implemented in accordance with Special Conditions S3, S4, and S9 of the CSWGP.

As site work progresses the SWPPP will be modified routinely to reflect changing site conditions. The SWPPP will be reviewed monthly to ensure the content is current.

Table 5 – Management

x	Design the project to fit the existing topography, soils, and drainage patterns
x	Emphasize erosion control rather than sediment control
x	Minimize the extent and duration of the area exposed
x	Keep runoff velocities low
x	Retain sediment on-site
x	Thoroughly monitor site and maintain all ESC measures
	Schedule major earthwork during the dry season
	Other (please describe)

Element 13: Protect Low Impact Development (LID) BMPs (2.1.13)

There will not be any LID BMPs used onsite.

Pollution Prevention Team (3.0)

Table 7 – Team Information

Title	Name(s)	Phone Number
Certified Erosion and Sediment Control Lead (CESCL)	TBD	TBD
Resident Engineer	John Anderson, PE	(425) 827-2014
Emergency Ecology Contact	After Hours Emergency Number	(425) 649-7000
Emergency Permittee/ Owner Contact	TBD	TBD
Non-Emergency Owner Contact	TBD	TBD
Monitoring Personnel	TBD	TBD
Ecology Regional Office	Northwest Regional Office	(425) 649-7000

Monitoring and Sampling Requirements (4.0)

Monitoring includes visual inspection, sampling for water quality parameters of concern, and documentation of the inspection and sampling findings in a site log book. A site log book will be maintained for all on-site construction activities and will include:

- A record of the implementation of the SWPPP and other permit requirements
- Site inspections
- Stormwater sampling data

A blank site inspection form is located in Appendix D.

The site log book must be maintained on-site within reasonable access to the site and be made available upon request to Ecology or the local jurisdiction.

Numeric effluent limits may be required for certain discharges to 303(d) listed waterbodies. See CSWGP Special Condition S8 and Section 5 of this template.

Site Inspection (4.1)

Site inspections will be conducted at least once every calendar week and within 24 hours following any discharge from the site. For sites that are temporarily stabilized and inactive, the required frequency is reduced to once per calendar month.

The discharge point(s) are indicated on the Site Map (see Appendix A) and in accordance with the applicable requirements of the CSWGP.

Stormwater Quality Sampling (4.2)

Turbidity Sampling (4.2.1)

Requirements include calibrated turbidity meter or transparency tube to sample site discharges for compliance with the CSWGP. Sampling will be conducted at all discharge points at least once per calendar week.

Method for sampling turbidity:

Table 8 – Turbidity Sampling Method

	Turbidity Meter/Turbidimeter (required for disturbances 5 acres or greater in size)
	Transparency Tube (option for disturbances less than 1 acre and up to 5 acres in size)

The benchmark for turbidity value is 25 nephelometric turbidity units (NTU) and a transparency less than 33 centimeters.

If the discharge's turbidity is 26 to 249 NTU or the transparency is less than 33 cm but equal to or greater than 6 cm, the following steps will be conducted:

1. Review the SWPPP for compliance with Special Condition S9. Make appropriate revisions within 7 days of the date the discharge exceeded the benchmark.
2. Immediately begin the process to fully implement and maintain appropriate source control and/or treatment BMPs as soon as possible. Address the problems within 10 days of the date the discharge exceeded the benchmark. If installation of necessary treatment BMPs is not feasible within 10 days, Ecology may approve additional time when the Permittee requests an extension within the initial 10-day response period.
3. Document BMP implementation and maintenance in the site log book.

If the turbidity exceeds 250 NTU or the transparency is 6 cm or less at any time, the following steps will be conducted:

1. Telephone or submit an electronic report to the applicable Ecology Region's Environmental Report Tracking System (ERTS) within 24 hours.
<https://www.ecology.wa.gov/About-us/Get-involved/Report-an-environmental-issue>
 - Central Region (Benton, Chelan, Douglas, Kittitas, Klickitat, Okanogan, Yakima): (509) 575-2490
 - Eastern Region (Adams, Asotin, Columbia, Ferry, Franklin, Garfield, Grant, Lincoln, Pend Oreille, Spokane, Stevens, Walla Walla, Whitman): (509) 329-3400
 - Northwest Region (King, Kitsap, Island, San Juan, Skagit, Snohomish, Whatcom): (425) 649-7000
 - Southwest Region (Clallam, Clark, Cowlitz, Grays Harbor, Jefferson, Lewis, Mason, Pacific, Pierce, Skamania, Thurston, Wahkiakum,): (360) 407-6300
2. Immediately begin the process to fully implement and maintain appropriate source control and/or treatment BMPs as soon as possible. Address the problems within 10 days of the date the discharge exceeded the benchmark. If installation of necessary treatment BMPs is not feasible within 10 days, Ecology may approve additional time when the Permittee requests an extension within the initial 10-day response period
3. Document BMP implementation and maintenance in the site log book.
4. Continue to sample discharges daily until one of the following is true:
 - Turbidity is 25 NTU (or lower).
 - Transparency is 33 cm (or greater).
 - Compliance with the water quality limit for turbidity is achieved.
 - 1 - 5 NTU over background turbidity, if background is less than 50 NTU
 - 1% - 10% over background turbidity, if background is 50 NTU or greater
 - The discharge stops or is eliminated.

pH Sampling (4.2.2)

pH monitoring is required for “Significant concrete work” (i.e. greater than 1000 cubic yards poured concrete or recycled concrete over the life of the project). The use of engineered soils (soil amendments including but not limited to Portland cement-treated base [CTB], cement kiln dust [CKD] or fly ash) also requires pH monitoring.

For significant concrete work, pH sampling will start the first day concrete is poured and continue until it is cured, typically three (3) weeks after the last pour.

For engineered soils and recycled concrete, pH sampling begins when engineered soils or recycled concrete are first exposed to precipitation and continues until the area is fully stabilized.

If the measured pH is 8.5 or greater, the following measures will be taken:

1. Prevent high pH water from entering storm sewer systems or surface water.
2. Adjust or neutralize the high pH water to the range of 6.5 to 8.5 su using appropriate technology such as carbon dioxide (CO₂) sparging (liquid or dry ice).
3. Written approval will be obtained from Ecology prior to the use of chemical treatment other than CO₂ sparging or dry ice.

Method for sampling pH:

Table 8 – pH Sampling Method

	pH meter
	pH test kit
	Wide range pH indicator paper

Discharges to 303(d) or Total Maximum Daily Load (TMDL) Waterbodies (5.0)

303(d) Listed Waterbodies (5.1)

Is the receiving water 303(d) (Category 5) listed for turbidity, fine sediment, phosphorus, or pH?

No

List the impairment(s):

N/A

List and describe BMPs:

N/A

Results showing that the receiving waterbody is not listed as 303(d) can be found in Appendix E.

TMDL Waterbodies (5.2)

Waste Load Allocation for CWSGP discharges:

The project site does not discharge to a listed TMDL water body.

List and describe BMPs:

N/A

Reporting and Record Keeping (6.0)

Record Keeping (6.1)

Site Log Book (6.1.1)

A site log book will be maintained for all on-site construction activities and will include:

- A record of the implementation of the SWPPP and other permit requirements
- Site inspections
- Sample logs

Records Retention (6.1.2)

Records will be retained during the life of the project and for a minimum of three (3) years following the termination of permit coverage in accordance with Special Condition S5.C of the CSWGP.

Permit documentation to be retained on-site:

- CSWGP
- Permit Coverage Letter
- SWPPP
- Site Log Book

Permit documentation will be provided within 14 days of receipt of a written request from Ecology. A copy of the SWPPP or access to the SWPPP will be provided to the public when requested in writing in accordance with Special Condition S5.G.2.b of the CSWGP.

Updating the SWPPP (6.1.3)

The SWPPP will be modified if:

- Found ineffective in eliminating or significantly minimizing pollutants in stormwater discharges from the site.
- There is a change in design, construction, operation, or maintenance at the construction site that has, or could have, a significant effect on the discharge of pollutants to waters of the State.

The SWPPP will be modified within seven (7) days if inspection(s) or investigation(s) determine additional or modified BMPs are necessary for compliance. An updated timeline for BMP implementation will be prepared.

Reporting (6.2)

Discharge Monitoring Reports (6.2.1)

Cumulative soil disturbance is one (1) acre or larger; therefore, Discharge Monitoring Reports (DMRs) will be submitted to Ecology monthly. If there was no discharge during a given monitoring period the DMR will be submitted as required, reporting “No Discharge”. The DMR due date is fifteen (15) days following the end of each calendar month.

DMRs will be reported online through Ecology’s WQWebDMR System.

To sign up for WQWebDMR go to:

<https://www.ecology.wa.gov/Regulations-Permits/Guidance-technical-assistance/Water-quality-permits-guidance/WQWebPortal-guidance>

Notification of Noncompliance (6.2.2)

If any of the terms and conditions of the permit is not met, and the resulting noncompliance may cause a threat to human health or the environment, the following actions will be taken:

1. Ecology will be notified within 24-hours of the failure to comply by calling the applicable Regional office ERTS phone number (Regional office numbers listed below).
2. Immediate action will be taken to prevent the discharge/pollution or otherwise stop or correct the noncompliance. If applicable, sampling and analysis of any noncompliance will be repeated immediately, and the results submitted to Ecology within five (5) days of becoming aware of the violation.
3. A detailed written report describing the noncompliance will be submitted to Ecology within five (5) days, unless requested earlier by Ecology.

Anytime turbidity sampling indicates turbidity is 250 NTUs or greater, or water transparency is 6 cm or less, the Ecology Regional office will be notified by phone within 24 hours of analysis as required by Special Condition S5.A of the CSWGP.

- Central Region at (509) 575-2490 for Benton, Chelan, Douglas, Kittitas, Klickitat, Okanogan, or Yakima County
- Eastern Region at (509) 329-3400 for Adams, Asotin, Columbia, Ferry, Franklin, Garfield, Grant, Lincoln, Pend Oreille, Spokane, Stevens, Walla Walla, or Whitman County
- Northwest Region at (425) 649-7000 for Island, King, Kitsap, San Juan, Skagit, Snohomish, or Whatcom County
- Southwest Region at (360) 407-6300 for Clallam, Clark, Cowlitz, Grays Harbor, Jefferson, Lewis, Mason, Pacific, Pierce, Skamania, Thurston, or Wahkiakum

Include the following information:

1. Your name and / Phone number
2. Permit number
3. City / County of project
4. Sample results
5. Date / Time of call
6. Date / Time of sample
7. Project name

In accordance with Special Condition S4.D.5.b of the CSWGP, the Ecology Regional office will be notified if chemical treatment other than CO₂ sparging is planned for adjustment of high pH water.

Appendix/Glossary

A. Site Map

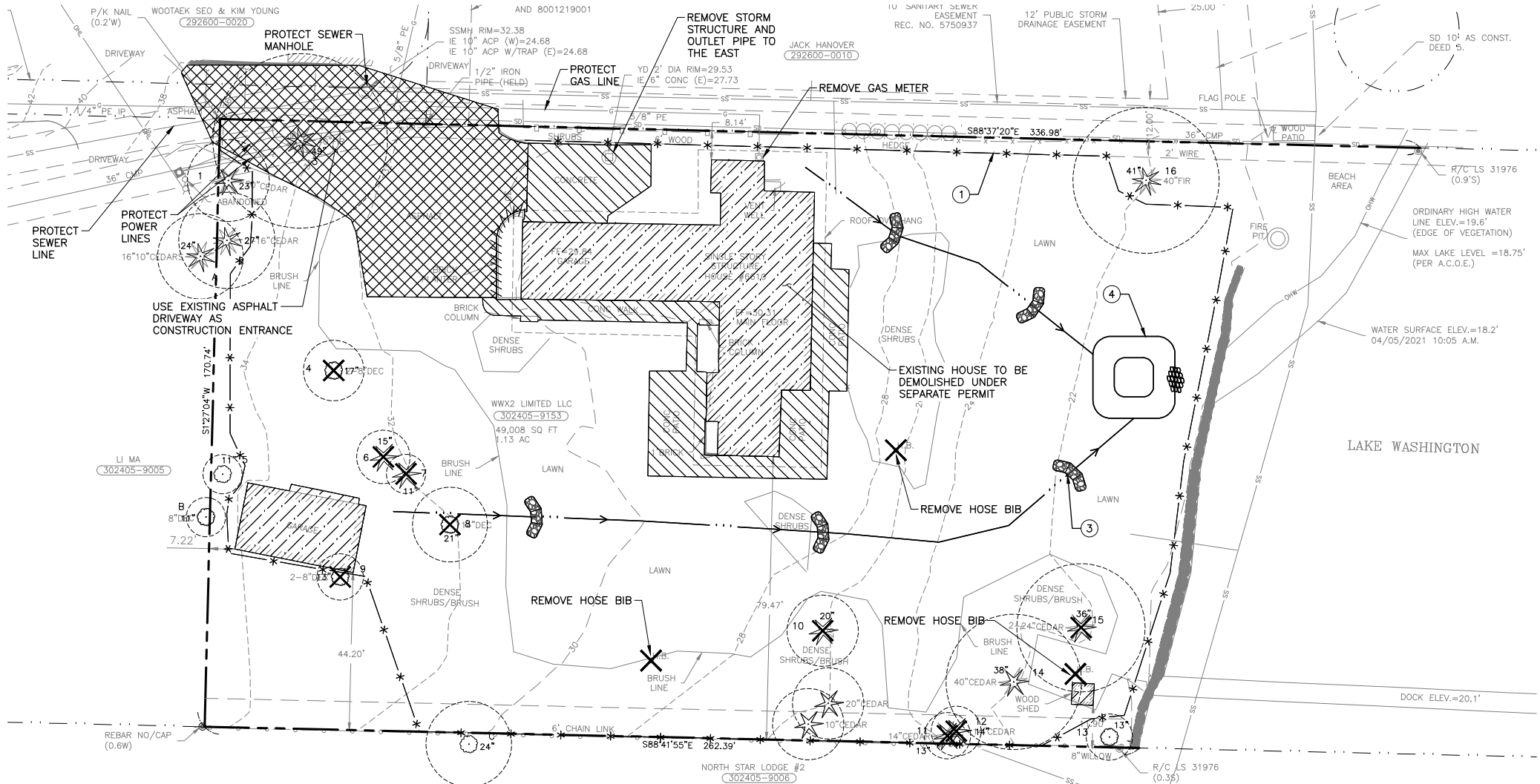

LEGEND:

- INLET PROTECTION
- SILT FENCE
- TREE PROTECTION FENCE PER CITY OF KIRKLAND DETAIL ON SEE SHEET C1.1
- PNA PROTECTION BOUNDARY
- INTERCEPTOR SWALE
- DEMOLISH FEATURE
- STRUCTURE TO BE DEMOLISHED
- PAVEMENT TO BE REMOVED
- CONCRETE TO BE REMOVED
- OBJECT TO BE REMOVED
- CHECK DAM PER CITY OF MERCER ISLAND DETAIL X.XX ON SHEET C1.1
- TEMPORARY SEDIMENT TRAP

GENERAL NOTES:

1. PRIOR TO ORDERING MATERIALS AND CONSTRUCTION, THE CONTRACTOR SHALL REVIEW THE PROJECT PLANS AND SITE CONDITIONS AND IDENTIFY IF ANY CONFLICTS EXIST. THE CONTRACTOR SHALL CALL "ONE-CALL" AND IDENTIFY AND ABOVE OR BELOW GRADE FEATURES ARE IN CONFLICT WITH THE PLANS. IF CONFLICTS EXIST CONTACT PACE ENGINEERS (425) 827-2014 WITH THE HORIZONTAL AND VERTICAL LOCATION OF THE CONFLICTS.
2. ALL WORK SHALL BE PERFORMED PER THE MOST CURRENT VERSION OF THE CITY OF MERCER ISLAND STANDARDS AND SPECIFICATIONS AS PROVIDED IN THIS PLAN SET.
3. SITE INSPECTIONS SHALL BE CONDUCTED BY A CERTIFIED EROSION AND SEDIMENT CONTROL LEAD (CESCL) WHO SHALL BE PRESENT ON-SITE OR ON-CALL AT ALL TIMES.

PROJECT CESCL: _____
 PHONE: _____

EROSION CONTROL NOTES:

- ① INSTALL SILT FENCE AT CLEARING LIMITS PER DETAIL X.XX ON SHEET C2.1.
- ② INSTALL TREE PROTECTION FENCING PER DETAIL ON SHEET C2.1.
- ③ INSTALL INTERCEPTOR SWALE WITH CHECK DAMS PER DETAIL ON SHEET C2.1.
- ④ SEDIMENT TRAP PER DETAIL ON SHEET 2.1.

CONSTRUCTION SEQUENCE

1. INSTALL FILTER FABRIC FENCES WHERE SHOWN ON THE PLAN.
2. INSTALL PROTECTION FENCING AROUND TREES WHERE SHOWN ON THE PLAN.
3. COORDINATE AND ATTEND PRE-CONSTRUCTION MEETING WITH CITY INSPECTOR.
4. INSTALL ROCK FOR CONSTRUCTION ACCESS.
5. DEMOLISH EXISTING HOUSE, GARAGE AND SHED WITHIN THE PROPERTY.
6. ROUGH GRADE SITE TO ESTABLISH BUILDING PAD AND DRIVEWAY.
7. INSTALL SEWER, STORM, WATER SERVICE LINES. FROM MAIN TO BUILDING SITE.
8. INSTALL BUILDING FOUNDATION.
9. FINISH GRADE LOT AND INSTALL LANDSCAPE PLANTING.
10. INSTALL FINAL PAVEMENT LIFT FOR DRIVEWAY.
11. REMOVE TESC MEASURES UPON APPROVAL OF CITY OF MERCER ISLAND INSPECTOR.

FILE NAME: P:\21436\KONERU\RESUBMIT\ENGINEERING\DWG\BUILDING\PERMIT\21436_TESC-SRF.DWG
 USER: JAV
 PLOT TIME: 12/21/2021 6:13 PM
 PLOT FILE: 21436_BDR.dwg
 9433-11-SRV.dwg
 121436_TREE.dwg
 21436_TESC.dwg

CALL BEFORE YOU DIG 811
 UNDERGROUND SERVICE (USA)

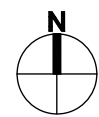

HORIZ. 0 10 20 40
 Scale in Feet

NO.	REVISION	DATE

PACE
 An Engineering Services Company
 11255 Kirkland Way, Suite 300
 Kirkland, WA 98033
 P. 425.827.2014 | F. 425.827.5043
 www.paceengr.com

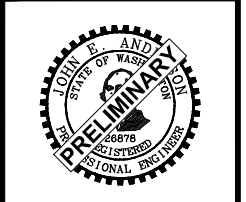

DHEERAJ KONERU
 7002 93RD AVENUE SE
 MERCER ISLAND, WA 98040

KONERU BUILDING PERMIT
 6610 EAST MERCER WAY
 MERCER ISLAND, WA 98040
 #####

VERIFY SCALE
 BAR IS ONE INCH ON ORIGINAL DRAWING.
 IF NOT ONE INCH ON THIS SHEET, ADJUST SCALES ACCORDINGLY.
 SCALE: 1"=20'
 DATE: 07/20/21
 DESIGNED BY: MA
 CHECKED BY: JA
 PACE PROJECT NO. 21436.00
C2.0
 SHEET

B. BMP Detail

BMP C101: Preserving Natural Vegetation

Purpose

The purpose of preserving natural vegetation is to reduce erosion wherever practicable. Limiting site disturbance is the single most effective method for reducing erosion. For example, conifers can hold up to about 50 percent of all rain that falls during a storm. Up to 20-30 percent of this rain may never reach the ground but is taken up by the tree or evaporates. Another benefit is that the rain held in the tree can be released slowly to the ground after the storm.

Conditions of Use

Natural vegetation should be preserved on steep slopes, near perennial and intermittent watercourses or swales, and on building sites in wooded areas.

- As required by local governments.
- Phase construction to preserve natural vegetation on the project site for as long as possible during the construction period.

Design and Installation Specifications

Natural vegetation can be preserved in natural clumps or as individual trees, shrubs and vines.

The preservation of individual plants is more difficult because heavy equipment is generally used to remove unwanted vegetation. The points to remember when attempting to save individual plants are:

- Is the plant worth saving? Consider the location, species, size, age, vigor, and the work involved. Local governments may also have ordinances to save natural vegetation and trees.
- Fence or clearly mark areas around trees that are to be saved. It is preferable to keep ground disturbance away from the trees at least as far out as the dripline.

Plants need protection from three kinds of injuries:

- *Construction Equipment* - This injury can be above or below the ground level. Damage results from scarring, cutting of roots, and compaction of the soil. Placing a fenced buffer zone around plants to be saved prior to construction can prevent construction equipment injuries.
- *Grade Changes* - Changing the natural ground level will alter grades, which affects the plant's ability to obtain the necessary air, water, and minerals. Minor fills usually do not cause problems although sensitivity between species does vary and should be checked. Trees can typically tolerate fill of 6 inches or less. For shrubs

and other plants, the fill should be less.

When there are major changes in grade, it may become necessary to supply air to the roots of plants. This can be done by placing a layer of gravel and a tile system over the roots before the fill is made. A tile system protects a tree from a raised grade. The tile system should be laid out on the original grade leading from a dry well around the tree trunk. The system should then be covered with small stones to allow air to circulate over the root area.

Lowering the natural ground level can seriously damage trees and shrubs. The highest percentage of the plant roots are in the upper 12 inches of the soil and cuts of only 2-3 inches can cause serious injury. To protect the roots it may be necessary to terrace the immediate area around the plants to be saved. If roots are exposed, construction of retaining walls may be needed to keep the soil in place. Plants can also be preserved by leaving them on an undisturbed, gently sloping mound. To increase the chances for survival, it is best to limit grade changes and other soil disturbances to areas outside the dripline of the plant.

- *Excavations* - Protect trees and other plants when excavating for drainfields, power, water, and sewer lines. Where possible, the trenches should be routed around trees and large shrubs. When this is not possible, it is best to tunnel under them. This can be done with hand tools or with power augers. If it is not possible to route the trench around plants to be saved, then the following should be observed:
 - Cut as few roots as possible. When you have to cut, cut clean. Paint cut root ends with a wood dressing like asphalt base paint if roots will be exposed for more than 24-hours.
 - Backfill the trench as soon as possible.
 - Tunnel beneath root systems as close to the center of the main trunk to preserve most of the important feeder roots.

Some problems that can be encountered with a few specific trees are:

- Maple, Dogwood, Red alder, Western hemlock, Western red cedar, and Douglas fir do not readily adjust to changes in environment and special care should be taken to protect these trees.
- The windthrow hazard of Pacific silver fir and madrona is high, while that of Western hemlock is moderate. The danger of windthrow increases where dense stands have been thinned. Other species (unless they are on shallow, wet soils less than 20 inches deep) have a low windthrow hazard.
- Cottonwoods, maples, and willows have water-seeking roots. These can cause trouble in sewer lines and infiltration fields. On the other hand, they thrive in high moisture conditions that other trees would not.
- Thinning operations in pure or mixed stands of Grand fir, Pacific silver fir, Noble fir,

Sitka spruce, Western red cedar, Western hemlock, Pacific dogwood, and Red alder can cause serious disease problems. Disease can become established through damaged limbs, trunks, roots, and freshly cut stumps. Diseased and weakened trees are also susceptible to insect attack.

Maintenance Standards

Inspect flagged and/or fenced areas regularly to make sure flagging or fencing has not been removed or damaged. If the flagging or fencing has been damaged or visibility reduced, it shall be repaired or replaced immediately and visibility restored.

- If tree roots have been exposed or injured, “prune” cleanly with an appropriate pruning saw or loppers directly above the damaged roots and recover with native soils. Treatment of sap flowing trees (fir, hemlock, pine, soft maples) is not advised as sap forms a natural healing barrier.

BMP C102: Buffer Zones

Purpose

Creation of an undisturbed area or strip of natural vegetation or an established suitable planting that will provide a living filter to reduce soil erosion and runoff velocities.

Conditions of Use

Natural buffer zones are used along streams, wetlands and other bodies of water that need protection from erosion and sedimentation. Vegetative buffer zones can be used to protect natural swales and can be incorporated into the natural landscaping of an area.

Critical-areas buffer zones should not be used as sediment treatment areas. These areas shall remain completely undisturbed. The local permitting authority may expand the buffer widths temporarily to allow the use of the expanded area for removal of sediment.

Design and Installation Specifications

- Preserving natural vegetation or plantings in clumps, blocks, or strips is generally the easiest and most successful method.
- Leave all unstable steep slopes in natural vegetation.
- Mark clearing limits and keep all equipment and construction debris out of the natural areas and buffer zones. Steel construction fencing is the most effective method in protecting sensitive areas and buffers. Alternatively, wire-backed silt fence on steel posts is marginally effective. Flagging alone is typically not effective.
- Keep all excavations outside the dripline of trees and shrubs.
- Do not push debris or extra soil into the buffer zone area because it will cause

damage from burying and smothering.

- Vegetative buffer zones for streams, lakes or other waterways shall be established by the local permitting authority or other state or federal permits or approvals.

Maintenance Standards

Inspect the area frequently to make sure flagging remains in place and the area remains undisturbed. Replace all damaged flagging immediately.

BMP C103: High Visibility Fence

Purpose

Fencing is intended to:

1. Restrict clearing to approved limits.
2. Prevent disturbance of sensitive areas, their buffers, and other areas required to be left undisturbed.
3. Limit construction traffic to designated construction entrances, exits, or internal roads.
4. Protect areas where marking with survey tape may not provide adequate protection.

Conditions of Use

To establish clearing limits plastic, fabric, or metal fence may be used:

- At the boundary of sensitive areas, their buffers, and other areas required to be left uncleared.
- As necessary to control vehicle access to and on the site.

Design and Installation Specifications

High visibility plastic fence shall be composed of a high-density polyethylene material and shall be at least four feet in height. Posts for the fencing shall be steel or wood and placed every 6 feet on center (maximum) or as needed to ensure rigidity. The fencing shall be fastened to the post every six inches with a polyethylene tie. On long continuous lengths of fencing, a tension wire or rope shall be used as a top stringer to prevent sagging between posts. The fence color shall be high visibility orange. The fence tensile strength shall be 360 lbs./ft. using the ASTM D4595 testing method.

If appropriate install fabric silt fence in accordance with [BMP C233: Silt Fence \(p.367\)](#) to act as high visibility fence. Silt fence shall be at least 3 feet high and must be highly visible to meet the requirements of this BMP.

Metal fences shall be designed and installed according to the manufacturer's specifications.

Metal fences shall be at least 3 feet high and must be highly visible.

Fences shall not be wired or stapled to trees.

Maintenance Standards

If the fence has been damaged or visibility reduced, it shall be repaired or replaced immediately and visibility restored.

BMP C105: Stabilized Construction Entrance / Exit

Purpose

Stabilized Construction entrances are established to reduce the amount of sediment transported onto paved roads by vehicles or equipment. This is done by constructing a stabilized pad of quarry spalls at entrances and exits for construction sites.

Conditions of Use

Construction entrances shall be stabilized wherever traffic will be entering or leaving a construction site if paved roads or other paved areas are within 1,000 feet of the site.

For residential construction provide stabilized construction entrances for each residence, rather than only at the main subdivision entrance. Stabilized surfaces shall be of sufficient length/width to provide vehicle access/parking, based on lot size/configuration.

On large commercial, highway, and road projects, the designer should include enough extra materials in the contract to allow for additional stabilized entrances not shown in the initial Construction SWPPP. It is difficult to determine exactly where access to these projects will take place; additional materials will enable the contractor to install them where needed.

Design and Installation Specifications

See [Figure II-4.1.1 Stabilized Construction Entrance \(p.273\)](#) for details. Note: the 100' minimum length of the entrance shall be reduced to the maximum practicable size when the size or configuration of the site does not allow the full length (100').

Construct stabilized construction entrances with a 12-inch thick pad of 4-inch to 8-inch quarry spalls, a 4-inch course of asphalt treated base (ATB), or use existing pavement. Do not use crushed concrete, cement, or calcium chloride for construction entrance stabilization because these products raise pH levels in stormwater and concrete discharge to surface waters of the State is prohibited.

A separation geotextile shall be placed under the spalls to prevent fine sediment from pumping up into the rock pad. The geotextile shall meet the following standards:

Grab Tensile Strength (ASTM D4751)	200 psi min.
Grab Tensile Elongation (ASTM D4632)	30% max.
Mullen Burst Strength (ASTM D3786-80a)	400 psi min.
AOS (ASTM D4751)	20-45 (U.S. standard sieve size)

- Consider early installation of the first lift of asphalt in areas that will be paved; this can be used as a stabilized entrance. Also consider the installation of excess concrete as a stabilized entrance. During large concrete pours, excess concrete is often available for this purpose.
- Fencing (see [BMP C103: High Visibility Fence \(p.269\)](#)) shall be installed as necessary to restrict traffic to the construction entrance.
- Whenever possible, the entrance shall be constructed on a firm, compacted sub-grade. This can substantially increase the effectiveness of the pad and reduce the need for maintenance.
- Construction entrances should avoid crossing existing sidewalks and back of walk drains if at all possible. If a construction entrance must cross a sidewalk or back of walk drain, the full length of the sidewalk and back of walk drain must be covered and protected from sediment leaving the site.

Maintenance Standards

Quarry spalls shall be added if the pad is no longer in accordance with the specifications.

- If the entrance is not preventing sediment from being tracked onto pavement, then alternative measures to keep the streets free of sediment shall be used. This may include replacement/cleaning of the existing quarry spalls, street sweeping, an increase in the dimensions of the entrance, or the installation of a wheel wash.
- Any sediment that is tracked onto pavement shall be removed by shoveling or street sweeping. The sediment collected by sweeping shall be removed or stabilized on site. The pavement shall not be cleaned by washing down the street, except when high efficiency sweeping is ineffective and there is a threat to public safety. If it is necessary to wash the streets, the construction of a small sump to contain the wash water shall be considered. The sediment would then be washed into the sump where it can be controlled.
- Perform street sweeping by hand or with a high efficiency sweeper. Do not use a non-high efficiency mechanical sweeper because this creates dust and throws soils into storm systems or conveyance ditches.

- Any quarry spalls that are loosened from the pad, which end up on the roadway shall be removed immediately.
- If vehicles are entering or exiting the site at points other than the construction entrance(s), fencing (see BMP C103) shall be installed to control traffic.
- Upon project completion and site stabilization, all construction accesses intended as permanent access for maintenance shall be permanently stabilized.

Figure II-4.1.1 Stabilized Construction Entrance

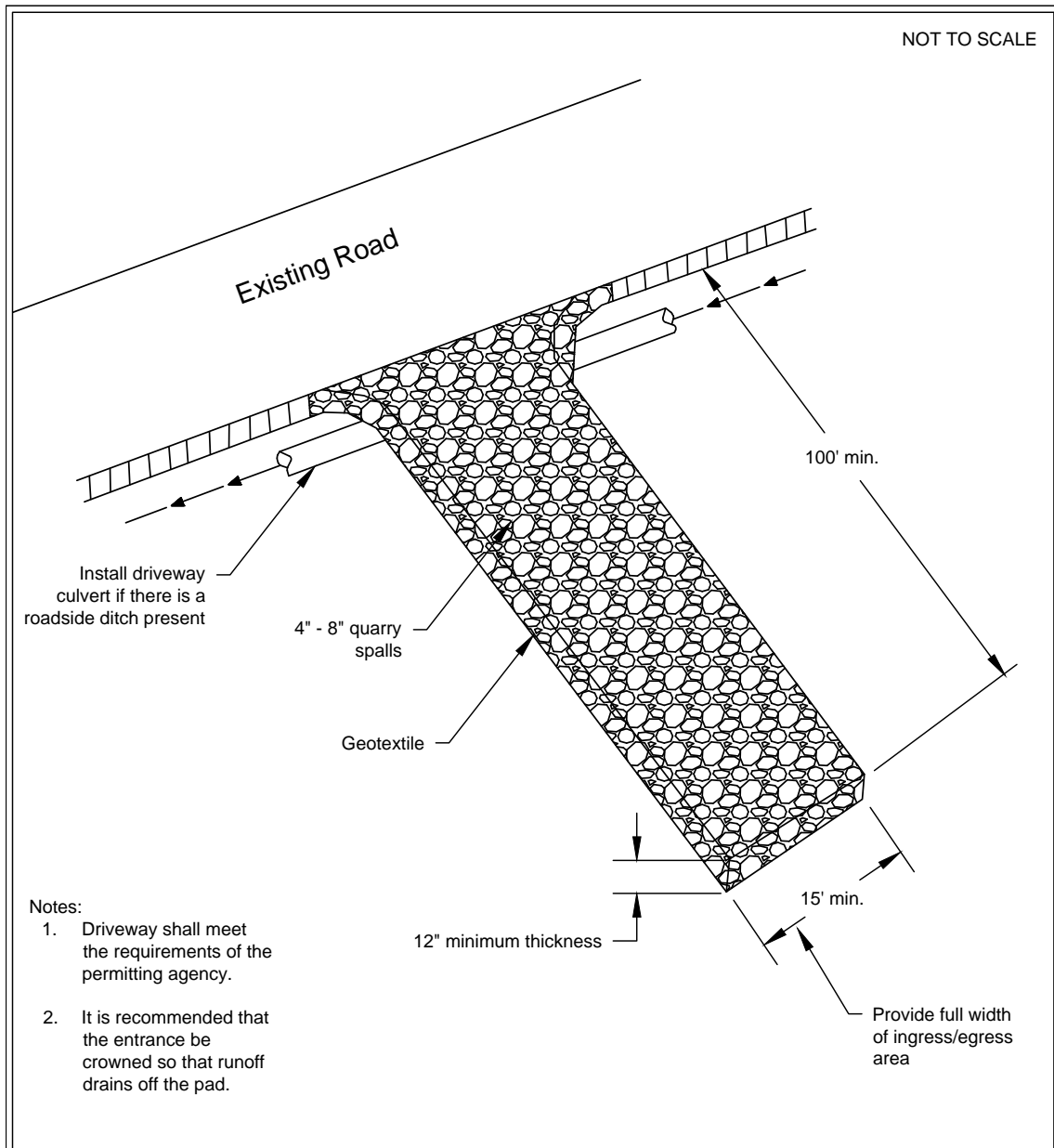

**Figure II-4.1.1
Stabilized Construction Entrance**

Revised June 2015

Please see <http://www.ecy.wa.gov/copyright.html> for copyright notice including permissions, limitation of liability, and disclaimer.

Approved as Equivalent

Ecology has approved products as able to meet the requirements of [BMP C105: Stabilized Construction Entrance / Exit](#). The products did not pass through the Technology Assessment Protocol – Ecology (TAPE) process. Local jurisdictions may choose not to accept this product approved as equivalent, or may require additional testing prior to consideration for local use. The products are available for review on Ecology’s website at <http://www.ecy.wa.gov/programs/wq/stormwater/newtech/equivalent.html>

BMP C106: Wheel Wash

Purpose

Wheel washes reduce the amount of sediment transported onto paved roads by motor vehicles.

Conditions of Use

When a stabilized construction entrance (see [BMP C105: Stabilized Construction Entrance / Exit \(p.270\)](#)) is not preventing sediment from being tracked onto pavement.

- Wheel washing is generally an effective BMP when installed with careful attention to topography. For example, a wheel wash can be detrimental if installed at the top of a slope abutting a right-of-way where the water from the dripping truck can run unimpeded into the street.
- Pressure washing combined with an adequately sized and surfaced pad with direct drainage to a large 10-foot x 10-foot sump can be very effective.
- Discharge wheel wash or tire bath wastewater to a separate on-site treatment system that prevents discharge to surface water, such as closed-loop recirculation or upland land application, or to the sanitary sewer with local sewer district approval.
- Wheel wash or tire bath wastewater should not include wastewater from concrete washout areas.

Design and Installation Specifications

Suggested details are shown in [Figure II-4.1.2 Wheel Wash \(p.276\)](#). The Local Permitting Authority may allow other designs. A minimum of 6 inches of asphalt treated base (ATB) over crushed base material or 8 inches over a good subgrade is recommended to pave the wheel wash.

Use a low clearance truck to test the wheel wash before paving. Either a belly dump or lowboy will work well to test clearance.

Keep the water level from 12 to 14 inches deep to avoid damage to truck hubs and filling the truck tongues with water.

- Storm drain inlets shall be protected to prevent sediment-laden water entering the storm drain system (see [BMP C220: Storm Drain Inlet Protection \(p.357\)](#)).

Maintenance Standards

Inspect stabilized areas regularly, especially after large storm events.

Crushed rock, gravel base, etc., shall be added as required to maintain a stable driving surface and to stabilize any areas that have eroded.

Following construction, these areas shall be restored to pre-construction condition or better to prevent future erosion.

Perform street cleaning at the end of each day or more often if necessary.

BMP C120: Temporary and Permanent Seeding

Purpose

Seeding reduces erosion by stabilizing exposed soils. A well-established vegetative cover is one of the most effective methods of reducing erosion.

Conditions of Use

Use seeding throughout the project on disturbed areas that have reached final grade or that will remain unworked for more than 30 days.

The optimum seeding windows for western Washington are April 1 through June 30 and September 1 through October 1.

Between July 1 and August 30 seeding requires irrigation until 75 percent grass cover is established.

Between October 1 and March 30 seeding requires a cover of mulch with straw or an erosion control blanket until 75 percent grass cover is established.

Review all disturbed areas in late August to early September and complete all seeding by the end of September. Otherwise, vegetation will not establish itself enough to provide more than average protection.

- Mulch is required at all times for seeding because it protects seeds from heat, moisture loss, and transport due to runoff. Mulch can be applied on top of the seed or simultaneously by hydroseeding. See [BMP C121: Mulching \(p.284\)](#) for specifications.
- Seed and mulch, all disturbed areas not otherwise vegetated at final site stabilization. Final stabilization means the completion of all soil disturbing activities at the site and the establishment of a permanent vegetative cover, or equivalent per-

manent stabilization measures (such as pavement, riprap, gabions, or geotextiles) which will prevent erosion.

Design and Installation Specifications

Seed retention/detention ponds as required.

Install channels intended for vegetation before starting major earthwork and hydroseed with a Bonded Fiber Matrix. For vegetated channels that will have high flows, install erosion control blankets over hydroseed. Before allowing water to flow in vegetated channels, establish 75 percent vegetation cover. If vegetated channels cannot be established by seed before water flow; install sod in the channel bottom—over hydromulch and erosion control blankets.

- Confirm the installation of all required surface water control measures to prevent seed from washing away.
- Hydroseed applications shall include a minimum of 1,500 pounds per acre of mulch with 3 percent tackifier. See [BMP C121: Mulching \(p.284\)](#) for specifications.
- Areas that will have seeding only and not landscaping may need compost or meal-based mulch included in the hydroseed in order to establish vegetation. Re-install native topsoil on the disturbed soil surface before application.
- When installing seed via hydroseeding operations, only about 1/3 of the seed actually ends up in contact with the soil surface. This reduces the ability to establish a good stand of grass quickly. To overcome this, consider increasing seed quantities by up to 50 percent.
- Enhance vegetation establishment by dividing the hydromulch operation into two phases:
 1. Phase 1- Install all seed and fertilizer with 25-30 percent mulch and tackifier onto soil in the first lift.
 2. Phase 2- Install the rest of the mulch and tackifier over the first lift.

Or, enhance vegetation by:

1. Installing the mulch, seed, fertilizer, and tackifier in one lift.
2. Spread or blow straw over the top of the hydromulch at a rate of 800-1000 pounds per acre.
3. Hold straw in place with a standard tackifier.

Both of these approaches will increase cost moderately but will greatly improve and enhance vegetative establishment. The increased cost may be offset by the reduced need for:

- Irrigation.
- Reapplication of mulch.
- Repair of failed slope surfaces.

This technique works with standard hydromulch (1,500 pounds per acre minimum) and BFM/MBFMs (3,000 pounds per acre minimum).

- Seed may be installed by hand if:
 - Temporary and covered by straw, mulch, or topsoil.
 - Permanent in small areas (usually less than 1 acre) and covered with mulch, topsoil, or erosion blankets.
 - The seed mixes listed in the tables below include recommended mixes for both temporary and permanent seeding.
 - Apply these mixes, with the exception of the wetland mix, at a rate of 120 pounds per acre. This rate can be reduced if soil amendments or slow-release fertilizers are used.
 - Consult the local suppliers or the local conservation district for their recommendations because the appropriate mix depends on a variety of factors, including location, exposure, soil type, slope, and expected foot traffic. Alternative seed mixes approved by the local authority may be used.
 - Other mixes may be appropriate, depending on the soil type and hydrology of the area.
- [Table II-4.1.2 Temporary Erosion Control Seed Mix \(p.280\)](#) lists the standard mix for areas requiring a temporary vegetative cover.

Table II-4.1.2 Temporary Erosion Control Seed Mix

	% Weight	% Purity	% Germination
Chewings or annual blue grass <i>Festuca rubra var. commutata</i> or <i>Poa annua</i>	40	98	90
Perennial rye <i>Lolium perenne</i>	50	98	90
Redtop or colonial bentgrass <i>Agrostis alba</i> or <i>Agrostis tenuis</i>	5	92	85
White dutch clover <i>Trifolium repens</i>	5	98	90

- [Table II-4.1.3 Landscaping Seed Mix \(p.281\)](#) lists a recommended mix for landscaping seed.

Table II-4.1.3 Landscaping Seed Mix

	% Weight	% Purity	% Germination
Perennial rye blend <i>Lolium perenne</i>	70	98	90
Chewings and red fescue blend <i>Festuca rubra</i> var. <i>commutata</i> or <i>Festuca rubra</i>	30	98	90

- [Table II-4.1.4 Low-Growing Turf Seed Mix \(p.281\)](#) lists a turf seed mix for dry situations where there is no need for watering. This mix requires very little maintenance.

Table II-4.1.4 Low-Growing Turf Seed Mix

	% Weight	% Purity	% Germination
Dwarf tall fescue (several varieties) <i>Festuca arundinacea</i> var.	45	98	90
Dwarf perennial rye (Barclay) <i>Lolium perenne</i> var. <i>barclay</i>	30	98	90
Red fescue <i>Festuca rubra</i>	20	98	90
Colonial bentgrass <i>Agrostis tenuis</i>	5	98	90

- [Table II-4.1.5 Bioswale Seed Mix* \(p.281\)](#) lists a mix for bioswales and other intermittently wet areas.

Table II-4.1.5 Bioswale Seed Mix*

	% Weight	% Purity	% Germination
Tall or meadow fescue <i>Festuca arundinacea</i> or <i>Festuca elatior</i>	75-80	98	90
Seaside/Creeping bentgrass <i>Agrostis palustris</i>	10-15	92	85
Redtop bentgrass <i>Agrostis alba</i> or <i>Agrostis gigantea</i>	5-10	90	80
* Modified Briargreen, Inc. Hydroseeding Guide Wetlands Seed Mix			

- [Table II-4.1.6 Wet Area Seed Mix* \(p.282\)](#) lists a low-growing, relatively non-invasive seed mix appropriate for very wet areas that are not regulated wetlands. Apply

this mixture at a rate of 60 pounds per acre. Consult Hydraulic Permit Authority (HPA) for seed mixes if applicable.

Table II-4.1.6 Wet Area Seed Mix*

	% Weight	% Purity	% Germination
Tall or meadow fescue <i>Festuca arundinacea</i> or <i>Festuca elatior</i>	60-70	98	90
Seaside/Creeping bentgrass <i>Agrostis palustris</i>	10-15	98	85
Meadow foxtail <i>Alepocurus pratensis</i>	10-15	90	80
Alsike clover <i>Trifolium hybridum</i>	1-6	98	90
Redtop bentgrass <i>Agrostis alba</i>	1-6	92	85
* Modified Briargreen, Inc. Hydroseeding Guide Wetlands Seed Mix			

- [Table II-4.1.7 Meadow Seed Mix \(p.282\)](#) lists a recommended meadow seed mix for infrequently maintained areas or non-maintained areas where colonization by native plants is desirable. Likely applications include rural road and utility right-of-way. Seeding should take place in September or very early October in order to obtain adequate establishment prior to the winter months. Consider the appropriateness of clover, a fairly invasive species, in the mix. Amending the soil can reduce the need for clover.

Table II-4.1.7 Meadow Seed Mix

	% Weight	% Purity	% Germination
Redtop or Oregon bentgrass <i>Agrostis alba</i> or <i>Agrostis oregonensis</i>	20	92	85
Red fescue <i>Festuca rubra</i>	70	98	90
White dutch clover <i>Trifolium repens</i>	10	98	90

• **Roughening and Rototilling:**

- The seedbed should be firm and rough. Roughen all soil no matter what the slope. Track walk slopes before seeding if engineering purposes require

compaction. Backblading or smoothing of slopes greater than 4H:1V is not allowed if they are to be seeded.

- Restoration-based landscape practices require deeper incorporation than that provided by a simple single-pass rototilling treatment. Wherever practical, initially rip the subgrade to improve long-term permeability, infiltration, and water inflow qualities. At a minimum, permanent areas shall use soil amendments to achieve organic matter and permeability performance defined in engineered soil/landscape systems. For systems that are deeper than 8 inches complete the rototilling process in multiple lifts, or prepare the engineered soil system per specifications and place to achieve the specified depth.

- **Fertilizers:**

- Conducting soil tests to determine the exact type and quantity of fertilizer is recommended. This will prevent the over-application of fertilizer.
- Organic matter is the most appropriate form of fertilizer because it provides nutrients (including nitrogen, phosphorus, and potassium) in the least water-soluble form.
- In general, use 10-4-6 N-P-K (nitrogen-phosphorus-potassium) fertilizer at a rate of 90 pounds per acre. Always use slow-release fertilizers because they are more efficient and have fewer environmental impacts. Do not add fertilizer to the hydromulch machine, or agitate, more than 20 minutes before use. Too much agitation destroys the slow-release coating.
- There are numerous products available that take the place of chemical fertilizers. These include several with seaweed extracts that are beneficial to soil microbes and organisms. If 100 percent cottonseed meal is used as the mulch in hydroseed, chemical fertilizer may not be necessary. Cottonseed meal provides a good source of long-term, slow-release, available nitrogen.

- **Bonded Fiber Matrix and Mechanically Bonded Fiber Matrix:**

- On steep slopes use Bonded Fiber Matrix (BFM) or Mechanically Bonded Fiber Matrix (MBFM) products. Apply BFM/MBFM products at a minimum rate of 3,000 pounds per acre of mulch with approximately 10 percent tackifier. Achieve a minimum of 95 percent soil coverage during application. Numerous products are available commercially. Installed products per manufacturer's instructions. Most products require 24-36 hours to cure before rainfall and cannot be installed on wet or saturated soils. Generally, products come in 40-50 pound bags and include all necessary ingredients except for seed and fertilizer.

- BFM and MBFMs provide good alternatives to blankets in most areas requiring vegetation establishment. Advantages over blankets include:
 - BFM and MBFMs do not require surface preparation.
 - Helicopters can assist in installing BFM and MBFMs in remote areas.
 - On slopes steeper than 2.5H:1V, blanket installers may require ropes and harnesses for safety.
 - Installing BFM and MBFMs can save at least \$1,000 per acre compared to blankets.

Maintenance Standards

Reseed any seeded areas that fail to establish at least 80 percent cover (100 percent cover for areas that receive sheet or concentrated flows). If reseeding is ineffective, use an alternate method such as sodding, mulching, or nets/blankets. If winter weather prevents adequate grass growth, this time limit may be relaxed at the discretion of the local authority when sensitive areas would otherwise be protected.

- Reseed and protect by mulch any areas that experience erosion after achieving adequate cover. Reseed and protect by mulch any eroded area.
- Supply seeded areas with adequate moisture, but do not water to the extent that it causes runoff.

Approved as Equivalent

Ecology has approved products as able to meet the requirements of [BMP C120: Temporary and Permanent Seeding](#). The products did not pass through the Technology Assessment Protocol – Ecology (TAPE) process. Local jurisdictions may choose not to accept this product approved as equivalent, or may require additional testing prior to consideration for local use. The products are available for review on Ecology’s website at <http://www.ecy.wa.gov/programs/wq/stormwater/newtech/equivalent.html>.

BMP C121: Mulching

Purpose

Mulching soils provides immediate temporary protection from erosion. Mulch also enhances plant establishment by conserving moisture, holding fertilizer, seed, and topsoil in place, and moderating soil temperatures. There is an enormous variety of mulches that can be used. This section discusses only the most common types of mulch.

Conditions of Use

As a temporary cover measure, mulch should be used:

- For less than 30 days on disturbed areas that require cover.
- At all times for seeded areas, especially during the wet season and during the hot summer months.
- During the wet season on slopes steeper than 3H:1V with more than 10 feet of vertical relief.

Mulch may be applied at any time of the year and must be refreshed periodically.

- For seeded areas mulch may be made up of 100 percent: cottonseed meal; fibers made of wood, recycled cellulose, hemp, kenaf; compost; or blends of these. Tackifier shall be plant-based, such as guar or alpha plantago, or chemical-based such as polyacrylamide or polymers. Any mulch or tackifier product used shall be installed per manufacturer's instructions. Generally, mulches come in 40-50 pound bags. Seed and fertilizer are added at time of application.

Design and Installation Specifications

For mulch materials, application rates, and specifications, see [Table II-4.1.8 Mulch Standards and Guidelines \(p.286\)](#). Always use a 2-inch minimum mulch thickness; increase the thickness until the ground is 95% covered (i.e. not visible under the mulch layer). Note: Thickness may be increased for disturbed areas in or near sensitive areas or other areas highly susceptible to erosion.

Where the option of "Compost" is selected, it should be a coarse compost that meets the following size gradations when tested in accordance with the U.S. Composting Council "Test Methods for the Examination of Compost and Composting" (TMECC) Test Method 02.02-B.

Coarse Compost

Minimum Percent passing 3" sieve openings 100%

Minimum Percent passing 1" sieve openings 90%

Minimum Percent passing ¾" sieve openings 70%

Minimum Percent passing ¼" sieve openings 40%

Mulch used within the ordinary high-water mark of surface waters should be selected to minimize potential flotation of organic matter. Composted organic materials have higher specific gravities (densities) than straw, wood, or chipped material. Consult Hydraulic Permit Authority (HPA) for mulch mixes if applicable.

Maintenance Standards

- The thickness of the cover must be maintained.
- Any areas that experience erosion shall be remulched and/or protected with a net

or blanket. If the erosion problem is drainage related, then the problem shall be fixed and the eroded area remulched.

Table II-4.1.8 Mulch Standards and Guidelines

Mulch Material	Quality Standards	Application Rates	Remarks
Straw	Air-dried; free from undesirable seed and coarse material.	2"-3" thick; 5 bales per 1,000 sf or 2-3 tons per acre	Cost-effective protection when applied with adequate thickness. Hand-application generally requires greater thickness than blown straw. The thickness of straw may be reduced by half when used in conjunction with seeding. In windy areas straw must be held in place by crimping, using a tackifier, or covering with netting. Blown straw always has to be held in place with a tackifier as even light winds will blow it away. Straw, however, has several deficiencies that should be considered when selecting mulch materials. It often introduces and/or encourages the propagation of weed species and it has no significant long-term benefits. It should also not be used within the ordinary high-water elevation of surface waters (due to flotation).
Hydromulch	No growth inhibiting factors.	Approx. 25-30 lbs per 1,000 sf or 1,500 - 2,000 lbs per acre	Shall be applied with hydromulcher. Shall not be used without seed and tackifier unless the application rate is at least doubled. Fibers longer than about 3/4 - 1 inch clog hydromulch equipment. Fibers should be kept to less than 3/4 inch.
Compost	No visible water or dust during handling. Must be produced per WAC 173-350, Solid Waste Handling Standards, but may have up to 35%	2" thick min.; approx. 100 tons per acre (approx. 800 lbs per yard)	More effective control can be obtained by increasing thickness to 3". Excellent mulch for protecting final grades until landscaping because it can be directly seeded or tilled into soil as an amendment. Compost used for mulch has a coarser size gradation than compost used for BMP C125: Topsoiling / Composting (p.297) or BMP T5.13: Post-Construction Soil Quality and Depth (p.911) . It is more stable and practical to use in wet areas and during rainy weather conditions. Do not use near wetlands or near phosphorous impaired water bodies.

Table II-4.1.8 Mulch Standards and Guidelines (continued)

Mulch Material	Quality Standards	Application Rates	Remarks
	biosolids.		
Chipped Site Vegetation	Average size shall be several inches. Gradations from fines to 6 inches in length for texture, variation, and interlocking properties.	2" thick min.;	This is a cost-effective way to dispose of debris from clearing and grubbing, and it eliminates the problems associated with burning. Generally, it should not be used on slopes above approx. 10% because of its tendency to be transported by runoff. It is not recommended within 200 feet of surface waters. If seeding is expected shortly after mulch, the decomposition of the chipped vegetation may tie up nutrients important to grass establishment.
Wood-based Mulch or Wood Straw	No visible water or dust during handling. Must be purchased from a supplier with a Solid Waste Handling Permit or one exempt from solid waste regulations.	2" thick min.; approx. 100 tons per acre (approx. 800 lbs. per cubic yard)	This material is often called "hog or hogged fuel". The use of mulch ultimately improves the organic matter in the soil. Special caution is advised regarding the source and composition of wood-based mulches. Its preparation typically does not provide any weed seed control, so evidence of residual vegetation in its composition or known inclusion of weed plants or seeds should be monitored and prevented (or minimized).
Wood Strand Mulch	A blend of loose, long, thin wood pieces derived from native conifer or deciduous trees with	2" thick min.	Cost-effective protection when applied with adequate thickness. A minimum of 95-percent of the wood strand shall have lengths between 2 and 10-inches, with a width and thickness between 1/16 and 3/8-inches. The mulch shall not contain resin, tannin, or other compounds in quantities that would be detrimental to plant life. Sawdust or wood shavings shall not be used as mulch. (WSDOT specification (9-14.4(4)))

Table II-4.1.8 Mulch Standards and Guidelines (continued)

Mulch Material	Quality Standards	Application Rates	Remarks
	high length-to-width ratio.		

BMP C122: Nets and Blankets

Purpose

Erosion control nets and blankets are intended to prevent erosion and hold seed and mulch in place on steep slopes and in channels so that vegetation can become well established. In addition, some nets and blankets can be used to permanently reinforce turf to protect drainage ways during high flows. Nets (commonly called matting) are strands of material woven into an open, but high-tensile strength net (for example, coconut fiber matting). Blankets are strands of material that are not tightly woven, but instead form a layer of interlocking fibers, typically held together by a biodegradable or photodegradable netting (for example, excelsior or straw blankets). They generally have lower tensile strength than nets, but cover the ground more completely. Coir (coconut fiber) fabric comes as both nets and blankets.

Conditions of Use

Erosion control nets and blankets should be used:

- To aid permanent vegetated stabilization of slopes 2H:1V or greater and with more than 10 feet of vertical relief.
- For drainage ditches and swales (highly recommended). The application of appropriate netting or blanket to drainage ditches and swales can protect bare soil from channelized runoff while vegetation is established. Nets and blankets also can capture a great deal of sediment due to their open, porous structure. Nets and blankets can be used to permanently stabilize channels and may provide a cost-effective, environmentally preferable alternative to riprap. 100 percent synthetic blankets manufactured for use in ditches may be easily reused as temporary ditch liners.

Disadvantages of blankets include:

- Surface preparation required.
- On slopes steeper than 2.5H:1V, blanket installers may need to be roped and harnessed for safety.
- They cost at least \$4,000-6,000 per acre installed.

Advantages of blankets include:

- Installation without mobilizing special equipment.
- Installation by anyone with minimal training
- Installation in stages or phases as the project progresses.
- Installers can hand place seed and fertilizer as they progress down the slope.
- Installation in any weather.
- There are numerous types of blankets that can be designed with various parameters in mind. Those parameters include: fiber blend, mesh strength, longevity, biodegradability, cost, and availability.

Design and Installation Specifications

- See [Figure II-4.1.3 Channel Installation \(p.292\)](#) and [Figure II-4.1.4 Slope Installation \(p.293\)](#) for typical orientation and installation of blankets used in channels and as slope protection. Note: these are typical only; all blankets must be installed per manufacturer's installation instructions.
- Installation is critical to the effectiveness of these products. If good ground contact is not achieved, runoff can concentrate under the product, resulting in significant erosion.
- Installation of Blankets on Slopes:
 1. Complete final grade and track walk up and down the slope.
 2. Install hydromulch with seed and fertilizer.
 3. Dig a small trench, approximately 12 inches wide by 6 inches deep along the top of the slope.
 4. Install the leading edge of the blanket into the small trench and staple approximately every 18 inches. NOTE: Staples are metal, "U"-shaped, and a minimum of 6 inches long. Longer staples are used in sandy soils. Biodegradable stakes are also available.
 5. Roll the blanket slowly down the slope as installer walks backwards. NOTE: The blanket rests against the installer's legs. Staples are installed as the blanket is unrolled. It is critical that the proper staple pattern is used for the blanket being installed. The blanket is not to be allowed to roll down the slope on its own as this stretches the blanket making it impossible to maintain soil contact. In addition, no one is allowed to walk on the blanket after it is in place.
 6. If the blanket is not long enough to cover the entire slope length, the trailing edge of the upper blanket should overlap the leading edge of the lower

blanket and be stapled. On steeper slopes, this overlap should be installed in a small trench, stapled, and covered with soil.

- With the variety of products available, it is impossible to cover all the details of appropriate use and installation. Therefore, it is critical that the design engineer consult the manufacturer's information and that a site visit takes place in order to ensure that the product specified is appropriate. Information is also available at the following web sites:

1. WSDOT (Section 3.2.4):

<http://www.wsdot.wa.gov/NR/rdonlyres/3B41E087-FA86-4717-932D-D7A8556CCD57/0/ErosionTrainingManual.pdf>

2. Texas Transportation Institute:

http://www.txdot.gov/business/doing_business/product_evaluation/erosion_control.htm

- Use jute matting in conjunction with mulch ([BMP C121: Mulching \(p.284\)](#)). Excelsior, woven straw blankets and coir (coconut fiber) blankets may be installed without mulch. There are many other types of erosion control nets and blankets on the market that may be appropriate in certain circumstances.
- In general, most nets (e.g., jute matting) require mulch in order to prevent erosion because they have a fairly open structure. Blankets typically do not require mulch because they usually provide complete protection of the surface.
- Extremely steep, unstable, wet, or rocky slopes are often appropriate candidates for use of synthetic blankets, as are riverbanks, beaches and other high-energy environments. If synthetic blankets are used, the soil should be hydromulched first.
- 100-percent biodegradable blankets are available for use in sensitive areas. These organic blankets are usually held together with a paper or fiber mesh and stitching which may last up to a year.
- Most netting used with blankets is photodegradable, meaning they break down under sunlight (not UV stabilized). However, this process can take months or years even under bright sun. Once vegetation is established, sunlight does not reach the mesh. It is not uncommon to find non-degraded netting still in place several years after installation. This can be a problem if maintenance requires the use of mowers or ditch cleaning equipment. In addition, birds and small animals can become trapped in the netting.

Maintenance Standards

- Maintain good contact with the ground. Erosion must not occur beneath the net or blanket.

- Repair and staple any areas of the net or blanket that are damaged or not in close contact with the ground.
- Fix and protect eroded areas if erosion occurs due to poorly controlled drainage.

Figure II-4.1.3 Channel Installation

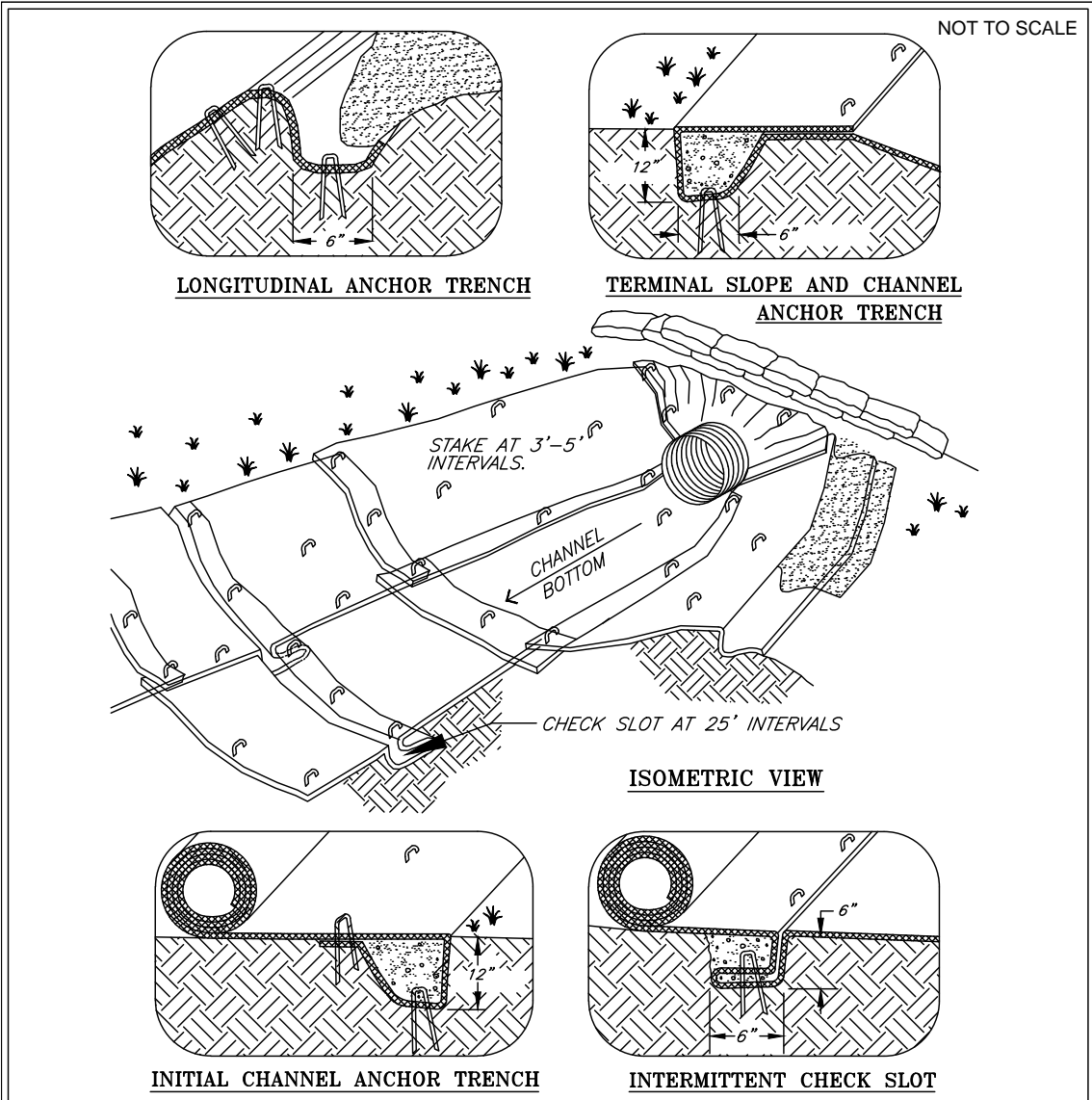

Source: Clackamas County 2009
Erosion Prevention Planning and
Design Manual

- Notes:
1. Check slots to be constructed per manufacturers specifications.
 2. Staking or stapling layout per manufacturers specifications.

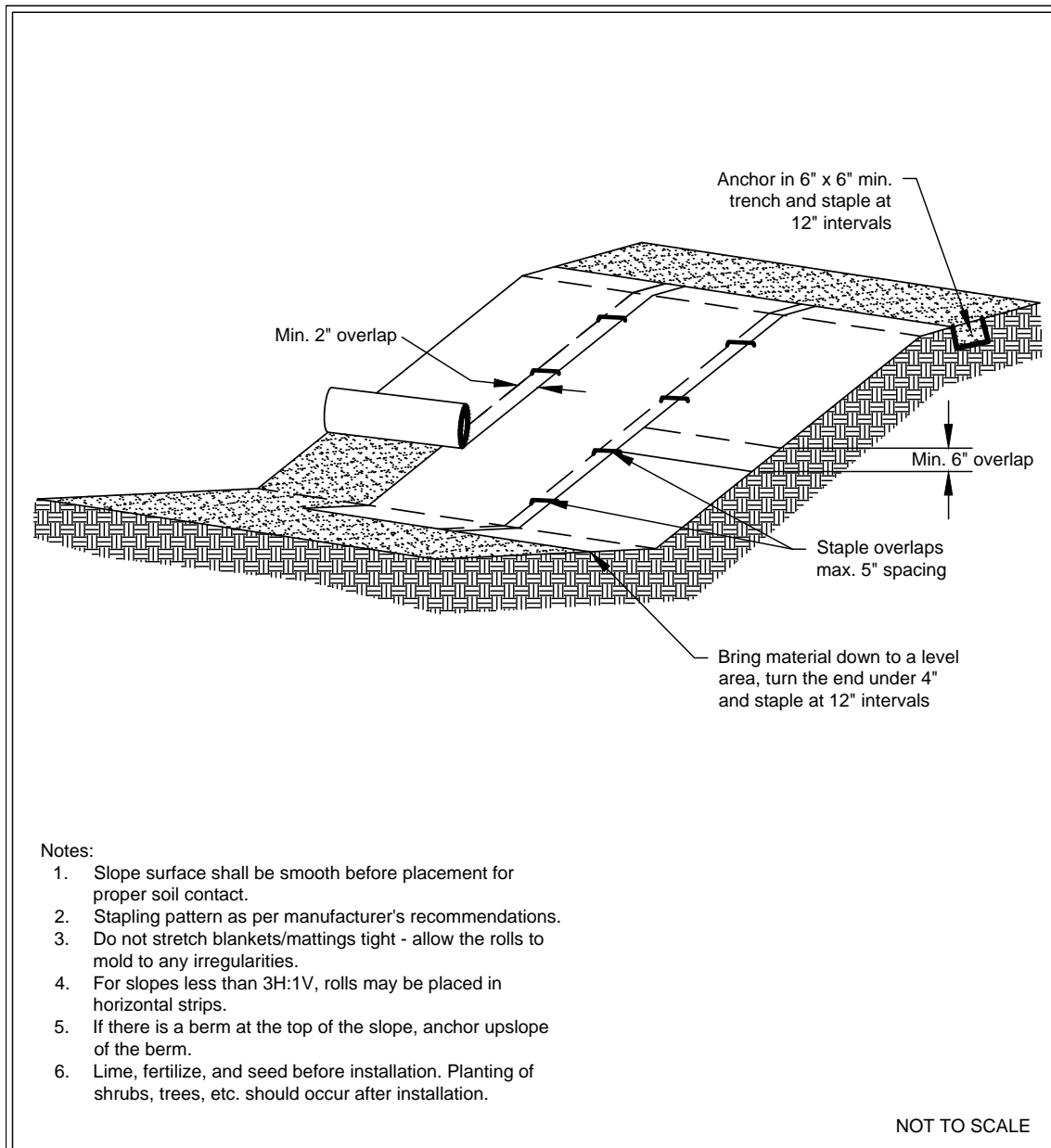

**Figure II-4.1.3
Channel Installation**

Revised June 2015

Please see <http://www.ecy.wa.gov/copyright.html> for copyright notice including permissions, limitation of liability, and disclaimer.

Figure II-4.1.4 Slope Installation



Notes:

1. Slope surface shall be smooth before placement for proper soil contact.
2. Stapling pattern as per manufacturer's recommendations.
3. Do not stretch blankets/mattings tight - allow the rolls to mold to any irregularities.
4. For slopes less than 3H:1V, rolls may be placed in horizontal strips.
5. If there is a berm at the top of the slope, anchor upslope of the berm.
6. Lime, fertilize, and seed before installation. Planting of shrubs, trees, etc. should occur after installation.



Figure II-4.1.4 Slope Installation

Revised June 2015

Please see <http://www.ecy.wa.gov/copyright.html> for copyright notice including permissions, limitation of liability, and disclaimer.

BMP C123: Plastic Covering

Purpose

Plastic covering provides immediate, short-term erosion protection to slopes and disturbed areas.

Conditions of Use

Plastic covering may be used on disturbed areas that require cover measures for less than 30 days, except as stated below.

- Plastic is particularly useful for protecting cut and fill slopes and stockpiles. Note: The relatively rapid breakdown of most polyethylene sheeting makes it unsuitable for long-term (greater than six months) applications.
- Due to rapid runoff caused by plastic covering, do not use this method upslope of areas that might be adversely impacted by concentrated runoff. Such areas include steep and/or unstable slopes.
- Plastic sheeting may result in increased runoff volumes and velocities, requiring additional on-site measures to counteract the increases. Creating a trough with wattles or other material can convey clean water away from these areas.
- To prevent undercutting, trench and backfill rolled plastic covering products.
- While plastic is inexpensive to purchase, the added cost of installation, maintenance, removal, and disposal make this an expensive material, up to \$1.50-2.00 per square yard.
- Whenever plastic is used to protect slopes install water collection measures at the base of the slope. These measures include plastic-covered berms, channels, and pipes used to convey clean rainwater away from bare soil and disturbed areas. Do not mix clean runoff from a plastic covered slope with dirty runoff from a project.
- Other uses for plastic include:
 1. Temporary ditch liner.
 2. Pond liner in temporary sediment pond.
 3. Liner for bermed temporary fuel storage area if plastic is not reactive to the type of fuel being stored.
 4. Emergency slope protection during heavy rains.
 5. Temporary drainpipe (“elephant trunk”) used to direct water.

Design and Installation Specifications

- Plastic slope cover must be installed as follows:
 1. Run plastic up and down slope, not across slope.
 2. Plastic may be installed perpendicular to a slope if the slope length is less than 10 feet.
 3. Minimum of 8-inch overlap at seams.
 4. On long or wide slopes, or slopes subject to wind, tape all seams.
 5. Place plastic into a small (12-inch wide by 6-inch deep) slot trench at the top of the slope and backfill with soil to keep water from flowing underneath.
 6. Place sand filled burlap or geotextile bags every 3 to 6 feet along seams and tie them together with twine to hold them in place.
 7. Inspect plastic for rips, tears, and open seams regularly and repair immediately. This prevents high velocity runoff from contacting bare soil which causes extreme erosion.
 8. Sandbags may be lowered into place tied to ropes. However, all sandbags must be staked in place.
- Plastic sheeting shall have a minimum thickness of 0.06 millimeters.
- If erosion at the toe of a slope is likely, a gravel berm, riprap, or other suitable protection shall be installed at the toe of the slope in order to reduce the velocity of runoff.

Maintenance Standards

- Torn sheets must be replaced and open seams repaired.
- Completely remove and replace the plastic if it begins to deteriorate due to ultra-violet radiation.
- Completely remove plastic when no longer needed.
- Dispose of old tires used to weight down plastic sheeting appropriately.

Approved as Equivalent

Ecology has approved products as able to meet the requirements of [BMP C123: Plastic Covering](#). The products did not pass through the Technology Assessment Protocol – Ecology (TAPE) process. Local jurisdictions may choose not to accept this product approved as equivalent, or may require additional testing prior to consideration for local use. The products are available for review on Ecology’s website at <http://www.ecy.wa.gov/programs/wq/stormwater/newtech/equivalent.html>

BMP C124: Sodding

Purpose

The purpose of sodding is to establish permanent turf for immediate erosion protection and to stabilize drainage ways where concentrated overland flow will occur.

Conditions of Use

Sodding may be used in the following areas:

- Disturbed areas that require short-term or long-term cover.
- Disturbed areas that require immediate vegetative cover.
- All waterways that require vegetative lining. Waterways may also be seeded rather than sodded, and protected with a net or blanket.

Design and Installation Specifications

Sod shall be free of weeds, of uniform thickness (approximately 1-inch thick), and shall have a dense root mat for mechanical strength.

The following steps are recommended for sod installation:

- Shape and smooth the surface to final grade in accordance with the approved grading plan. The swale needs to be overexcavated 4 to 6 inches below design elevation to allow room for placing soil amendment and sod.
- Amend 4 inches (minimum) of compost into the top 8 inches of the soil if the organic content of the soil is less than ten percent or the permeability is less than 0.6 inches per hour. See <http://www.ecy.wa.gov/programs/swfa/organics/soil.html> for further information.
- Fertilize according to the supplier's recommendations.
- Work lime and fertilizer 1 to 2 inches into the soil, and smooth the surface.
- Lay strips of sod beginning at the lowest area to be sodded and perpendicular to the direction of water flow. Wedge strips securely into place. Square the ends of each strip to provide for a close, tight fit. Stagger joints at least 12 inches. Staple on slopes steeper than 3H:1V. Staple the upstream edge of each sod strip.
- Roll the sodded area and irrigate.
- When sodding is carried out in alternating strips or other patterns, seed the areas between the sod immediately after sodding.

Maintenance Standards

If the grass is unhealthy, the cause shall be determined and appropriate action taken to reestablish a healthy groundcover. If it is impossible to establish a healthy groundcover due to frequent saturation, instability, or some other cause, the sod shall be removed, the area seeded with an appropriate mix, and protected with a net or blanket.

BMP C125: Topsoiling / Composting

Purpose

Topsoiling and composting provide a suitable growth medium for final site stabilization with vegetation. While not a permanent cover practice in itself, topsoiling and composting are an integral component of providing permanent cover in those areas where there is an unsuitable soil surface for plant growth. Use this BMP in conjunction with other BMPs such as seeding, mulching, or sodding. Note that this BMP is functionally the same as [BMP T5.13: Post-Construction Soil Quality and Depth \(p.911\)](#) which is required for all disturbed areas that will be developed as lawn or landscaped areas at the completed project site.

Native soils and disturbed soils that have been organically amended not only retain much more stormwater, but they also serve as effective biofilters for urban pollutants and, by supporting more vigorous plant growth, reduce the water, fertilizer and pesticides needed to support installed landscapes. Topsoil does not include any subsoils but only the material from the top several inches including organic debris.

Conditions of Use

- Permanent landscaped areas shall contain healthy topsoil that reduces the need for fertilizers, improves overall topsoil quality, provides for better vegetal health and vitality, improves hydrologic characteristics, and reduces the need for irrigation.
- Leave native soils and the duff layer undisturbed to the maximum extent practicable. Stripping of existing, properly functioning soil system and vegetation for the purpose of topsoiling during construction is not acceptable. Preserve existing soil systems in undisturbed and uncompacted conditions if functioning properly.
- Areas that already have good topsoil, such as undisturbed areas, do not require soil amendments.
- Restore, to the maximum extent practical, native soils disturbed during clearing and grading to a condition equal to or better than the original site condition's moisture-holding capacity. Use on-site native topsoil, incorporate amendments into on-site soil, or import blended topsoil to meet this requirement.
- Topsoiling is a required procedure when establishing vegetation on shallow soils, and soils of critically low pH (high acid) levels.

- Beware of where the topsoil comes from, and what vegetation was on site before disturbance, invasive plant seeds may be included and could cause problems for establishing native plants, landscaped areas, or grasses.
- Topsoil from the site will contain mycorrhizal bacteria that are necessary for healthy root growth and nutrient transfer. These native mycorrhiza are acclimated to the site and will provide optimum conditions for establishing grasses. Use commercially available mycorrhiza products when using off-site topsoil.

Design and Installation Specifications

Meet the following requirements for disturbed areas that will be developed as lawn or landscaped areas at the completed project site:

- Maximize the depth of the topsoil wherever possible to provide the maximum possible infiltration capacity and beneficial growth medium. Topsoil shall have:
 - A minimum depth of 8-inches. Scarify subsoils below the topsoil layer at least 4-inches with some incorporation of the upper material to avoid stratified layers, where feasible. Ripping or re-structuring the subgrade may also provide additional benefits regarding the overall infiltration and interflow dynamics of the soil system.
 - A minimum organic content of 10% dry weight in planting beds, and 5% organic matter content in turf areas. Incorporate organic amendments to a minimum 8-inch depth except where tree roots or other natural features limit the depth of incorporation.
 - A pH between 6.0 and 8.0 or matching the pH of the undisturbed soil.
 - If blended topsoil is imported, then fines should be limited to 25 percent passing through a 200 sieve.
 - Mulch planting beds with 2 inches of organic material
- Accomplish the required organic content, depth, and pH by returning native topsoil to the site, importing topsoil of sufficient organic content, and/or incorporating organic amendments. When using the option of incorporating amendments to meet the organic content requirement, use compost that meets the compost specification for Bioretention (See [BMP T7.30: Bioretention Cells, Swales, and Planter Boxes \(p.959\)](#)), with the exception that the compost may have up to 35% biosolids or manure.
- Sections three through seven of the document entitled, *Guidelines and Resources for Implementing Soil Quality and Depth BMP T5.13 in WDOE Stormwater Management Manual for Western Washington*, provides useful guidance for implementing whichever option is chosen. It includes guidance for pre-approved default strategies and guidance for custom strategies. Check with your local jurisdiction

concerning its acceptance of this guidance. It is available through the organization, Soils for Salmon. As of this printing the document may be found at: http://www.soilsforsalmon.org/pdf/Soil_BMP_Manual.pdf.

- The final composition and construction of the soil system will result in a natural selection or favoring of certain plant species over time. For example, incorporation of topsoil may favor grasses, while layering with mildly acidic, high-carbon amendments may favor more woody vegetation.
- Allow sufficient time in scheduling for topsoil spreading prior to seeding, sodding, or planting.
- Take care when applying top soil to subsoils with contrasting textures. Sandy topsoil over clayey subsoil is a particularly poor combination, as water creeps along the junction between the soil layers and causes the topsoil to slough. If topsoil and subsoil are not properly bonded, water will not infiltrate the soil profile evenly and it will be difficult to establish vegetation. The best method to prevent a lack of bonding is to actually work the topsoil into the layer below for a depth of at least 6 inches.
- Field exploration of the site shall be made to determine if there is surface soil of sufficient quantity and quality to justify stripping. Topsoil shall be friable and loamy (loam, sandy loam, silt loam, sandy clay loam, and clay loam). Avoid areas of natural ground water recharge.
- Stripping shall be confined to the immediate construction area. A 4-inch to 6-inch stripping depth is common, but depth may vary depending on the particular soil. All surface runoff control structures shall be in place prior to stripping.
- Do not place topsoil while in a frozen or muddy condition, when the subgrade is excessively wet, or when conditions exist that may otherwise be detrimental to proper grading or proposed sodding or seeding.
- In any areas requiring grading remove and stockpile the duff layer and topsoil on site in a designated, controlled area, not adjacent to public resources and critical areas. Stockpiled topsoil is to be reapplied to other portions of the site where feasible.
- Locate the topsoil stockpile so that it meets specifications and does not interfere with work on the site. It may be possible to locate more than one pile in proximity to areas where topsoil will be used.

Stockpiling of topsoil shall occur in the following manner:

- Side slopes of the stockpile shall not exceed 2H:1V.
- Between October 1 and April 30:

- An interceptor dike with gravel outlet and silt fence shall surround all topsoil.
- Within 2 days complete erosion control seeding, or covering stockpiles with clear plastic, or other mulching materials.
- Between May 1 and September 30:
 - An interceptor dike with gravel outlet and silt fence shall surround all topsoil if the stockpile will remain in place for a longer period of time than active construction grading.
 - Within 7 days complete erosion control seeding, or covering stockpiles with clear plastic, or other mulching materials.
- When native topsoil is to be stockpiled and reused the following should apply to ensure that the mycorrhizal bacterial, earthworms, and other beneficial organisms will not be destroyed:
 1. Re-install topsoil within 4 to 6 weeks.
 2. Do not allow the saturation of topsoil with water.
 3. Do not use plastic covering.

Maintenance Standards

- Inspect stockpiles regularly, especially after large storm events. Stabilize any areas that have eroded.
- Establish soil quality and depth toward the end of construction and once established, protect from compaction, such as from large machinery use, and from erosion.
- Plant and mulch soil after installation.
- Leave plant debris or its equivalent on the soil surface to replenish organic matter.
- Reduce and adjust, where possible, the use of irrigation, fertilizers, herbicides and pesticides, rather than continuing to implement formerly established practices.

BMP C126: Polyacrylamide (PAM) for Soil Erosion Protection

Purpose

Polyacrylamide (PAM) is used on construction sites to prevent soil erosion.

Applying PAM to bare soil in advance of a rain event significantly reduces erosion and controls sediment in two ways. First, PAM increases the soil's available pore volume,

BMP C140: Dust Control

Purpose

Dust control prevents wind transport of dust from disturbed soil surfaces onto roadways, drainage ways, and surface waters.

Conditions of Use

- In areas (including roadways) subject to surface and air movement of dust where on-site and off-site impacts to roadways, drainage ways, or surface waters are likely.

Design and Installation Specifications

- Vegetate or mulch areas that will not receive vehicle traffic. In areas where planting, mulching, or paving is impractical, apply gravel or landscaping rock.
- Limit dust generation by clearing only those areas where immediate activity will take place, leaving the remaining area(s) in the original condition. Maintain the original ground cover as long as practical.
- Construct natural or artificial windbreaks or windscreens. These may be designed as enclosures for small dust sources.
- Sprinkle the site with water until surface is wet. Repeat as needed. To prevent carryout of mud onto street, refer to [BMP C105: Stabilized Construction Entrance / Exit \(p.270\)](#).
- Irrigation water can be used for dust control. Irrigation systems should be installed as a first step on sites where dust control is a concern.
- Spray exposed soil areas with a dust palliative, following the manufacturer's instructions and cautions regarding handling and application. Used oil is prohibited from use as a dust suppressant. Local governments may approve other dust palliatives such as calcium chloride or PAM.
- PAM ([BMP C126: Polyacrylamide \(PAM\) for Soil Erosion Protection \(p.300\)](#)) added to water at a rate of 0.5 lbs. per 1,000 gallons of water per acre and applied from a water truck is more effective than water alone. This is due to increased infiltration of water into the soil and reduced evaporation. In addition, small soil particles are bonded together and are not as easily transported by wind. Adding PAM may actually reduce the quantity of water needed for dust control. Use of PAM could be a cost-effective dust control method.

Techniques that can be used for unpaved roads and lots include:

- Lower speed limits. High vehicle speed increases the amount of dust stirred up from unpaved roads and lots.
- Upgrade the road surface strength by improving particle size, shape, and mineral types that make up the surface and base materials.
- Add surface gravel to reduce the source of dust emission. Limit the amount of fine particles (those smaller than .075 mm) to 10 to 20 percent.
- Use geotextile fabrics to increase the strength of new roads or roads undergoing reconstruction.
- Encourage the use of alternate, paved routes, if available.
- Restrict use of paved roadways by tracked vehicles and heavy trucks to prevent damage to road surface and base.
- Apply chemical dust suppressants using the admix method, blending the product with the top few inches of surface material. Suppressants may also be applied as surface treatments.
- Pave unpaved permanent roads and other trafficked areas.
- Use vacuum street sweepers.
- Remove mud and other dirt promptly so it does not dry and then turn into dust.
- Limit dust-causing work on windy days.
- Contact your local Air Pollution Control Authority for guidance and training on other dust control measures. Compliance with the local Air Pollution Control Authority constitutes compliance with this BMP.

Maintenance Standards

Respray area as necessary to keep dust to a minimum.

BMP C150: Materials on Hand

Purpose

Keep quantities of erosion prevention and sediment control materials on the project site at all times to be used for regular maintenance and emergency situations such as unexpected heavy summer rains. Having these materials on-site reduces the time needed to implement BMPs when inspections indicate that existing BMPs are not meeting the Construction SWPPP requirements. In addition, contractors can save money by buying some materials in bulk and storing them at their office or yard.

Conditions of Use

- Construction projects of any size or type can benefit from having materials on hand. A small commercial development project could have a roll of plastic and some gravel available for immediate protection of bare soil and temporary berm construction. A large earthwork project, such as highway construction, might have several tons of straw, several rolls of plastic, flexible pipe, sandbags, geotextile fabric and steel “T” posts.
- Materials are stockpiled and readily available before any site clearing, grubbing, or earthwork begins. A large contractor or developer could keep a stockpile of materials that are available for use on several projects.
- If storage space at the project site is at a premium, the contractor could maintain the materials at their office or yard. The office or yard must be less than an hour from the project site.

Design and Installation Specifications

Depending on project type, size, complexity, and length, materials and quantities will vary. A good minimum list of items that will cover numerous situations includes:

Material
Clear Plastic, 6 mil
Drainpipe, 6 or 8 inch diameter
Sandbags, filled
Straw Bales for mulching,
Quarry Spalls
Washed Gravel
Geotextile Fabric
Catch Basin Inserts
Steel "T" Posts
Silt fence material
Straw Wattles

Maintenance Standards

- All materials with the exception of the quarry spalls, steel “T” posts, and gravel should be kept covered and out of both sun and rain.
- Re-stock materials used as needed.

BMP C151: Concrete Handling

Purpose

Concrete work can generate process water and slurry that contain fine particles and high pH, both of which can violate water quality standards in the receiving water. Concrete spillage or concrete discharge to surface waters of the State is prohibited. Use this BMP to minimize and eliminate concrete, concrete process water, and concrete slurry from entering waters of the state.

Conditions of Use

Any time concrete is used, utilize these management practices. Concrete construction projects include, but are not limited to, the following:

- Curbs
- Sidewalks
- Roads
- Bridges
- Foundations
- Floors
- Runways

Design and Installation Specifications

- Assure that washout of concrete trucks, chutes, pumps, and internals is performed at an approved off-site location or in designated concrete washout areas. Do not wash out concrete trucks onto the ground, or into storm drains, open ditches, streets, or streams. Refer to [BMP C154: Concrete Washout Area \(p.317\)](#) for information on concrete washout areas.
- Return unused concrete remaining in the truck and pump to the originating batch plant for recycling. Do not dump excess concrete on site, except in designated concrete washout areas.
- Wash off hand tools including, but not limited to, screeds, shovels, rakes, floats, and trowels into formed areas only.
- Wash equipment difficult to move, such as concrete pavers in areas that do not directly drain to natural or constructed stormwater conveyances.
- Do not allow washdown from areas, such as concrete aggregate driveways, to drain directly to natural or constructed stormwater conveyances.
- Contain washwater and leftover product in a lined container when no formed areas

are available. Dispose of contained concrete in a manner that does not violate ground water or surface water quality standards.

- Always use forms or solid barriers for concrete pours, such as pilings, within 15-feet of surface waters.
- Refer to [BMP C252: High pH Neutralization Using CO2 \(p.409\)](#) and [BMP C253: pH Control for High pH Water \(p.412\)](#) for pH adjustment requirements.
- Refer to the Construction Stormwater General Permit for pH monitoring requirements if the project involves one of the following activities:
 - Significant concrete work (greater than 1,000 cubic yards poured concrete or recycled concrete used over the life of a project).
 - The use of engineered soils amended with (but not limited to) Portland cement-treated base, cement kiln dust or fly ash.
 - Discharging stormwater to segments of water bodies on the 303(d) list (Category 5) for high pH.

Maintenance Standards

Check containers for holes in the liner daily during concrete pours and repair the same day.

BMP C152: Sawcutting and Surfacing Pollution Prevention

Purpose

Sawcutting and surfacing operations generate slurry and process water that contains fine particles and high pH (concrete cutting), both of which can violate the water quality standards in the receiving water. Concrete spillage or concrete discharge to surface waters of the State is prohibited. Use this BMP to minimize and eliminate process water and slurry created through sawcutting or surfacing from entering waters of the State.

Conditions of Use

Utilize these management practices anytime sawcutting or surfacing operations take place. Sawcutting and surfacing operations include, but are not limited to, the following:

- Sawing
- Coring
- Grinding
- Roughening

- Hydro-demolition
- Bridge and road surfacing

Design and Installation Specifications

- Vacuum slurry and cuttings during cutting and surfacing operations.
- Slurry and cuttings shall not remain on permanent concrete or asphalt pavement overnight.
- Slurry and cuttings shall not drain to any natural or constructed drainage conveyance including stormwater systems. This may require temporarily blocking catch basins.
- Dispose of collected slurry and cuttings in a manner that does not violate ground water or surface water quality standards.
- Do not allow process water generated during hydro-demolition, surface roughening or similar operations to drain to any natural or constructed drainage conveyance including stormwater systems. Dispose process water in a manner that does not violate ground water or surface water quality standards.
- Handle and dispose cleaning waste material and demolition debris in a manner that does not cause contamination of water. Dispose of sweeping material from a pick-up sweeper at an appropriate disposal site.

Maintenance Standards

Continually monitor operations to determine whether slurry, cuttings, or process water could enter waters of the state. If inspections show that a violation of water quality standards could occur, stop operations and immediately implement preventive measures such as berms, barriers, secondary containment, and vacuum trucks.

BMP C153: Material Delivery, Storage and Containment

Purpose

Prevent, reduce, or eliminate the discharge of pollutants to the stormwater system or watercourses from material delivery and storage. Minimize the storage of hazardous materials on-site, store materials in a designated area, and install secondary containment.

Conditions of Use

These procedures are suitable for use at all construction sites with delivery and storage of the following materials:

- Petroleum products such as fuel, oil and grease
- Soil stabilizers and binders (e.g., Polyacrylamide)
- Fertilizers, pesticides and herbicides
- Detergents
- Asphalt and concrete compounds
- Hazardous chemicals such as acids, lime, adhesives, paints, solvents, and curing compounds
- Any other material that may be detrimental if released to the environment

Design and Installation Specifications

The following steps should be taken to minimize risk:

- Temporary storage area should be located away from vehicular traffic, near the construction entrance(s), and away from waterways or storm drains.
- Material Safety Data Sheets (MSDS) should be supplied for all materials stored. Chemicals should be kept in their original labeled containers.
- Hazardous material storage on-site should be minimized.
- Hazardous materials should be handled as infrequently as possible.
- During the wet weather season (Oct 1 – April 30), consider storing materials in a covered area.
- Materials should be stored in secondary containments, such as earthen dike, horse trough, or even a children’s wading pool for non-reactive materials such as detergents, oil, grease, and paints. Small amounts of material may be secondarily contained in “bus boy” trays or concrete mixing trays.
- Do not store chemicals, drums, or bagged materials directly on the ground. Place these items on a pallet and, when possible, and within secondary containment.
- If drums must be kept uncovered, store them at a slight angle to reduce ponding of rainwater on the lids to reduce corrosion. Domed plastic covers are inexpensive and snap to the top of drums, preventing water from collecting.

Material Storage Areas and Secondary Containment Practices:

- Liquids, petroleum products, and substances listed in 40 CFR Parts 110, 117, or 302 shall be stored in approved containers and drums and shall not be overfilled. Containers and drums shall be stored in temporary secondary containment facilities.
- Temporary secondary containment facilities shall provide for a spill containment

volume able to contain 10% of the total enclosed container volume of all containers, or 110% of the capacity of the largest container within its boundary, whichever is greater.

- Secondary containment facilities shall be impervious to the materials stored therein for a minimum contact time of 72 hours.
- Secondary containment facilities shall be maintained free of accumulated rainwater and spills. In the event of spills or leaks, accumulated rainwater and spills shall be collected and placed into drums. These liquids shall be handled as hazardous waste unless testing determines them to be non-hazardous.
- Sufficient separation should be provided between stored containers to allow for spill cleanup and emergency response access.
- During the wet weather season (Oct 1 – April 30), each secondary containment facility shall be covered during non-working days, prior to and during rain events.
- Keep material storage areas clean, organized and equipped with an ample supply of appropriate spill clean-up material (spill kit).
- The spill kit should include, at a minimum:
 - 1-Water Resistant Nylon Bag
 - 3-Oil Absorbent Socks 3"x 4'
 - 2-Oil Absorbent Socks 3"x 10'
 - 12-Oil Absorbent Pads 17"x19"
 - 1-Pair Splash Resistant Goggles
 - 3-Pair Nitrile Gloves
 - 10-Disposable Bags with Ties
 - Instructions

BMP C154: Concrete Washout Area

Purpose

Prevent or reduce the discharge of pollutants to stormwater from concrete waste by conducting washout off-site, or performing on-site washout in a designated area to prevent pollutants from entering surface waters or ground water.

Conditions of Use

Concrete washout area best management practices are implemented on construction projects where:

- Concrete is used as a construction material
- It is not possible to dispose of all concrete wastewater and washout off-site (ready mix plant, etc.).
- Concrete trucks, pumpers, or other concrete coated equipment are washed on-site.
- Note: If less than 10 concrete trucks or pumpers need to be washed out on-site, the washwater may be disposed of in a formed area awaiting concrete or an upland disposal site where it will not contaminate surface or ground water. The upland disposal site shall be at least 50 feet from sensitive areas such as storm drains, open ditches, or water bodies, including wetlands.

Design and Installation Specifications

Implementation

The following steps will help reduce stormwater pollution from concrete wastes:

- Perform washout of concrete trucks at an approved off-site location or in designated concrete washout areas only.
- Do not wash out concrete trucks onto the ground, or into storm drains, open ditches, streets, or streams.
- Do not allow excess concrete to be dumped on-site, except in designated concrete washout areas.
- Concrete washout areas may be prefabricated concrete washout containers, or self-installed structures (above-grade or below-grade).
- Prefabricated containers are most resistant to damage and protect against spills and leaks. Companies may offer delivery service and provide regular maintenance and disposal of solid and liquid waste.
- If self-installed concrete washout areas are used, below-grade structures are preferred over above-grade structures because they are less prone to spills and leaks.
- Self-installed above-grade structures should only be used if excavation is not practical.

Education

- Discuss the concrete management techniques described in this BMP with the ready-mix concrete supplier before any deliveries are made.
- Educate employees and subcontractors on the concrete waste management techniques described in this BMP.
- Arrange for contractor's superintendent or Certified Erosion and Sediment Control

Lead (CESCL) to oversee and enforce concrete waste management procedures.

- A sign should be installed adjacent to each temporary concrete washout facility to inform concrete equipment operators to utilize the proper facilities.

Contracts

Incorporate requirements for concrete waste management into concrete supplier and sub-contractor agreements.

Location and Placement

- Locate washout area at least 50 feet from sensitive areas such as storm drains, open ditches, or water bodies, including wetlands.
- Allow convenient access for concrete trucks, preferably near the area where the concrete is being poured.
- If trucks need to leave a paved area to access washout, prevent track-out with a pad of rock or quarry spalls (see [BMP C105: Stabilized Construction Entrance / Exit \(p.270\)](#)). These areas should be far enough away from other construction traffic to reduce the likelihood of accidental damage and spills.
- The number of facilities you install should depend on the expected demand for storage capacity.
- On large sites with extensive concrete work, washouts should be placed in multiple locations for ease of use by concrete truck drivers.

On-site Temporary Concrete Washout Facility, Transit Truck Washout Procedures:

- Temporary concrete washout facilities shall be located a minimum of 50 ft from sensitive areas including storm drain inlets, open drainage facilities, and water-courses. See [Figure II-4.1.7a Concrete Washout Area \(p.322\)](#), [Figure II-4.1.7b Concrete Washout Area \(p.323\)](#), and [Figure II-4.1.8 Prefabricated Concrete Washout Container w/Ramp \(p.324\)](#).
- Concrete washout facilities shall be constructed and maintained in sufficient quantity and size to contain all liquid and concrete waste generated by washout operations.
- Washout of concrete trucks shall be performed in designated areas only.
- Concrete washout from concrete pumper bins can be washed into concrete pumper trucks and discharged into designated washout area or properly disposed of off-site.
- Once concrete wastes are washed into the designated area and allowed to

harden, the concrete should be broken up, removed, and disposed of per applicable solid waste regulations. Dispose of hardened concrete on a regular basis.

- Temporary Above-Grade Concrete Washout Facility
 - Temporary concrete washout facility (type above grade) should be constructed as shown on the details below, with a recommended minimum length and minimum width of 10 ft, but with sufficient quantity and volume to contain all liquid and concrete waste generated by washout operations.
 - Plastic lining material should be a minimum of 10 mil polyethylene sheeting and should be free of holes, tears, or other defects that compromise the impermeability of the material.
- Temporary Below-Grade Concrete Washout Facility
 - Temporary concrete washout facilities (type below grade) should be constructed as shown on the details below, with a recommended minimum length and minimum width of 10 ft. The quantity and volume should be sufficient to contain all liquid and concrete waste generated by washout operations.
 - Lath and flagging should be commercial type.
 - Plastic lining material shall be a minimum of 10 mil polyethylene sheeting and should be free of holes, tears, or other defects that compromise the impermeability of the material.
 - Liner seams shall be installed in accordance with manufacturers' recommendations.
 - Soil base shall be prepared free of rocks or other debris that may cause tears or holes in the plastic lining material.

Maintenance Standards

Inspection and Maintenance

- Inspect and verify that concrete washout BMPs are in place prior to the commencement of concrete work.
- During periods of concrete work, inspect daily to verify continued performance.
 - Check overall condition and performance.
 - Check remaining capacity (% full).
 - If using self-installed washout facilities, verify plastic liners are intact and side-walls are not damaged.
 - If using prefabricated containers, check for leaks.

- Washout facilities shall be maintained to provide adequate holding capacity with a minimum freeboard of 12 inches.
- Washout facilities must be cleaned, or new facilities must be constructed and ready for use once the washout is 75% full.
- If the washout is nearing capacity, vacuum and dispose of the waste material in an approved manner.
 - Do not discharge liquid or slurry to waterways, storm drains or directly onto ground.
 - Do not use sanitary sewer without local approval.
 - Place a secure, non-collapsing, non-water collecting cover over the concrete washout facility prior to predicted wet weather to prevent accumulation and overflow of precipitation.
 - Remove and dispose of hardened concrete and return the structure to a functional condition. Concrete may be reused on-site or hauled away for disposal or recycling.
- When you remove materials from the self-installed concrete washout, build a new structure; or, if the previous structure is still intact, inspect for signs of weakening or damage, and make any necessary repairs. Re-line the structure with new plastic after each cleaning.

Removal of Temporary Concrete Washout Facilities

- When temporary concrete washout facilities are no longer required for the work, the hardened concrete, slurries and liquids shall be removed and properly disposed of.
- Materials used to construct temporary concrete washout facilities shall be removed from the site of the work and disposed of or recycled.
- Holes, depressions or other ground disturbance caused by the removal of the temporary concrete washout facilities shall be backfilled, repaired, and stabilized to prevent erosion.

Figure II-4.1.7a Concrete Washout Area

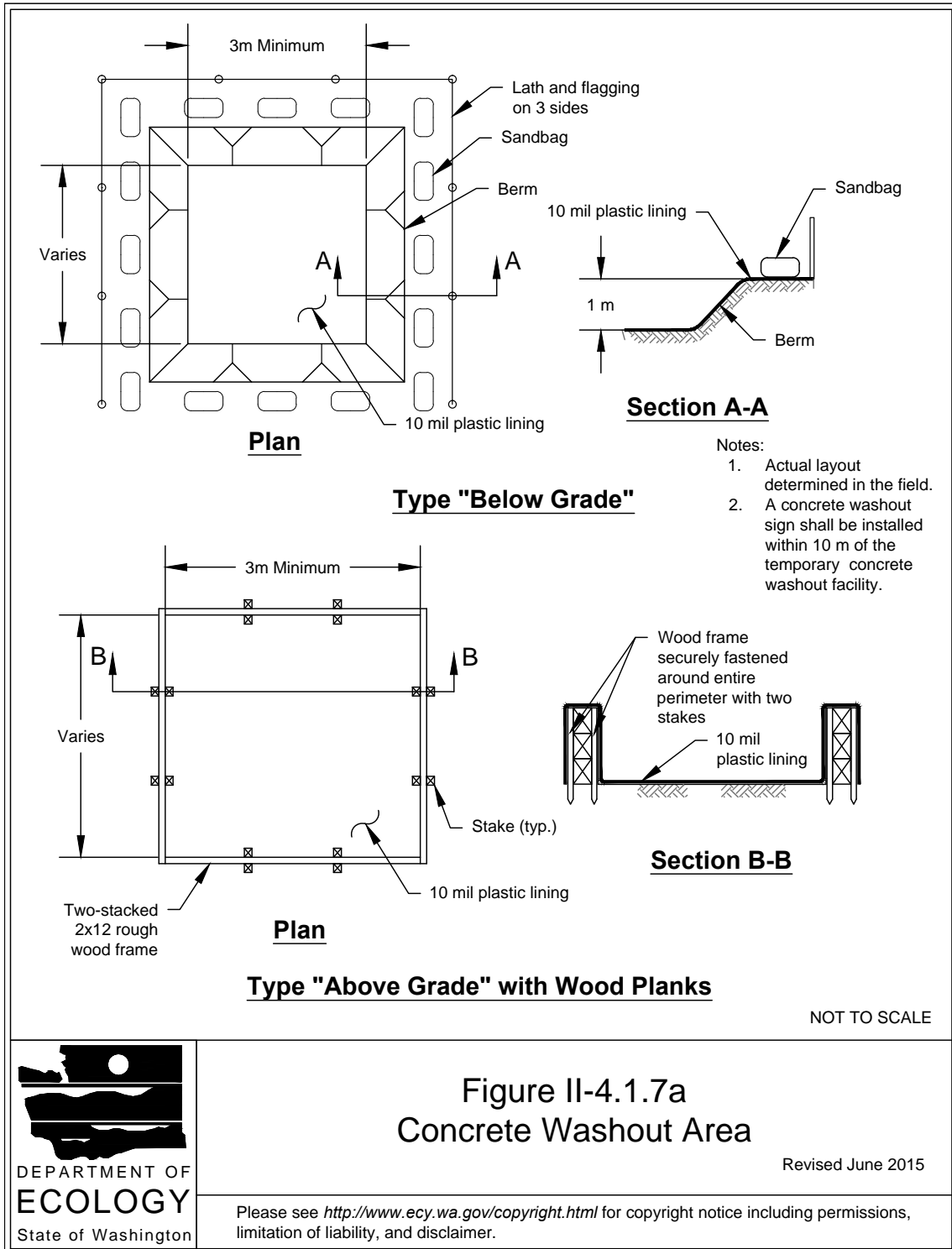
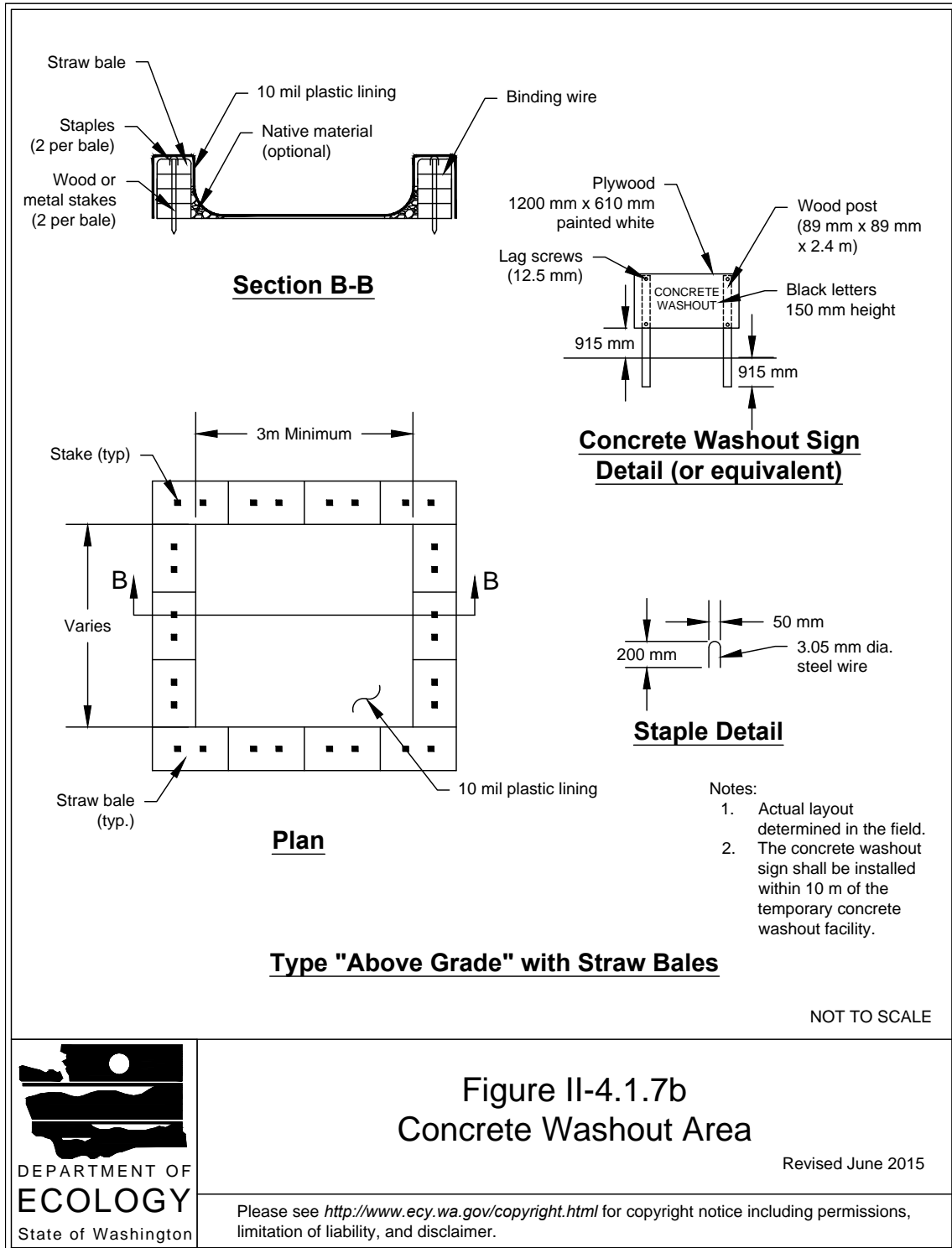

**Figure II-4.1.7a
Concrete Washout Area**

Revised June 2015

Please see <http://www.ecy.wa.gov/copyright.html> for copyright notice including permissions, limitation of liability, and disclaimer.

Figure II-4.1.7b Concrete Washout Area



**Figure II-4.1.7b
Concrete Washout Area**

Revised June 2015

Please see <http://www.ecy.wa.gov/copyright.html> for copyright notice including permissions, limitation of liability, and disclaimer.

Figure II-4.1.8 Prefabricated Concrete Washout Container w/Ramp

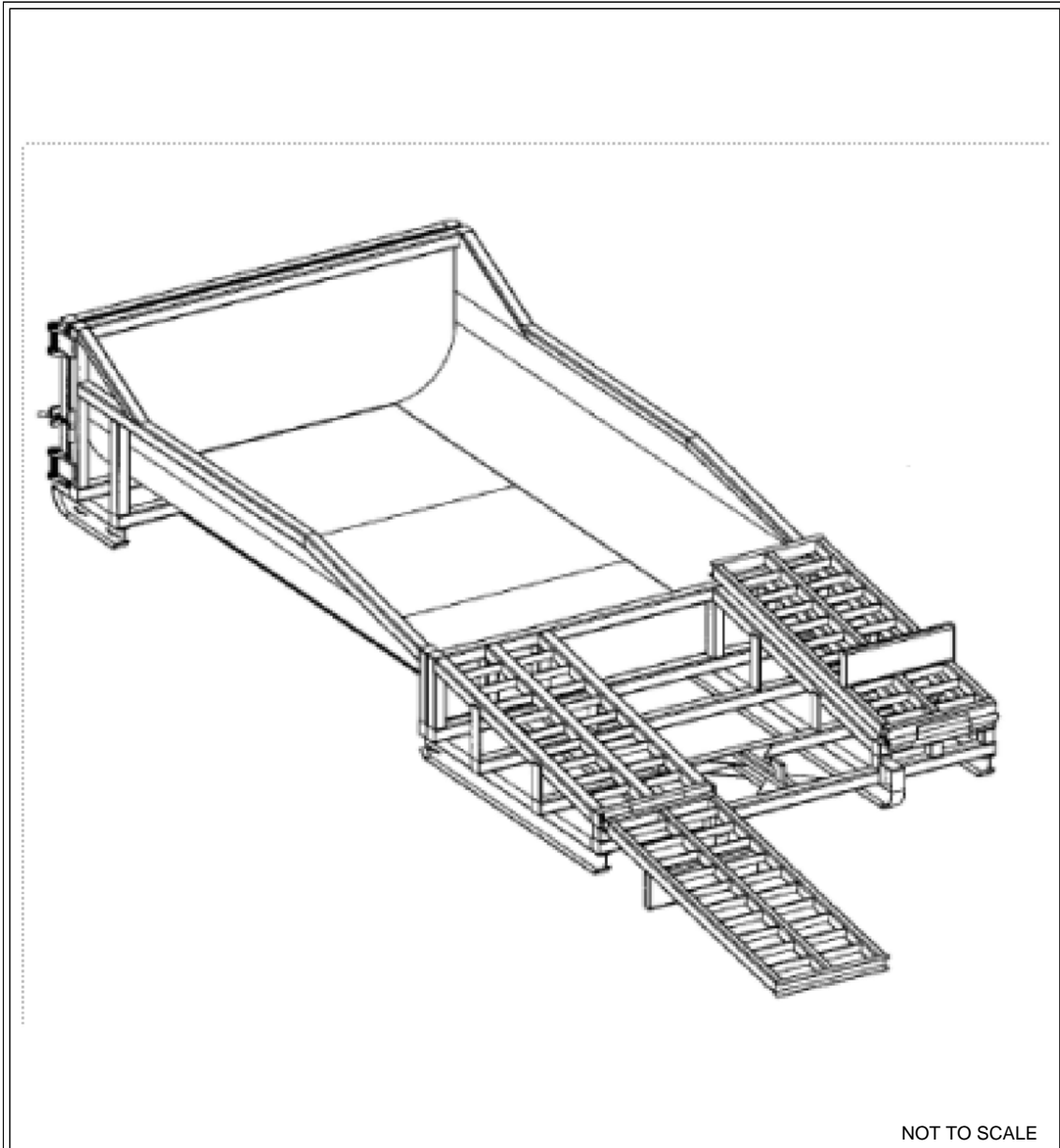

Figure II-4.1.8
Prefabricated Concrete Washout Container
w/Ramp

Revised June 2015

Please see <http://www.ecy.wa.gov/copyright.html> for copyright notice including permissions, limitation of liability, and disclaimer.

BMP C160: Certified Erosion and Sediment Control Lead

Purpose

The project proponent designates at least one person as the responsible representative in charge of erosion and sediment control (ESC), and water quality protection. The designated person shall be the Certified Erosion and Sediment Control Lead (CESCL) who is responsible for ensuring compliance with all local, state, and federal erosion and sediment control and water quality requirements.

Conditions of Use

A CESCL shall be made available on projects one acre or larger that discharge stormwater to surface waters of the state. Sites less than one acre may have a person without CESCL certification conduct inspections; sampling is not required on sites that disturb less than an acre.

- The CESCL shall:
 - Have a current certificate proving attendance in an erosion and sediment control training course that meets the minimum ESC training and certification requirements established by Ecology (see details below).

Ecology will maintain a list of ESC training and certification providers at:
<http://www.ecy.wa.gov/programs/wq/stormwater/cescl.html>

OR

- Be a Certified Professional in Erosion and Sediment Control (CPESC); for additional information go to: <http://www.envirocertintl.org/cpesc/>

Specifications

- Certification shall remain valid for three years.
- The CESCL shall have authority to act on behalf of the contractor or developer and shall be available, or on-call, 24 hours per day throughout the period of construction.
- The Construction SWPPP shall include the name, telephone number, fax number, and address of the designated CESCL.
- A CESCL may provide inspection and compliance services for multiple construction projects in the same geographic region.

Duties and responsibilities of the CESCL shall include, but are not limited to the following:

- Maintaining permit file on site at all times which includes the Construction SWPPP and any associated permits and plans.
- Directing BMP installation, inspection, maintenance, modification, and removal.
- Updating all project drawings and the Construction SWPPP with changes made.
- Completing any sampling requirements including reporting results using WebDMR.
- Keeping daily logs, and inspection reports. Inspection reports should include:
 - Inspection date/time.
 - Weather information; general conditions during inspection and approximate amount of precipitation since the last inspection.
 - A summary or list of all BMPs implemented, including observations of all erosion/sediment control structures or practices. The following shall be noted:
 1. Locations of BMPs inspected.
 2. Locations of BMPs that need maintenance.
 3. Locations of BMPs that failed to operate as designed or intended.
 4. Locations of where additional or different BMPs are required.
 - Visual monitoring results, including a description of discharged stormwater. The presence of suspended sediment, turbid water, discoloration, and oil sheen shall be noted, as applicable.
 - Any water quality monitoring performed during inspection.
 - General comments and notes, including a brief description of any BMP repairs, maintenance or installations made as a result of the inspection.
- Facilitate, participate in, and take corrective actions resulting from inspections performed by outside agencies or the owner.

BMP C162: Scheduling

Purpose

Sequencing a construction project reduces the amount and duration of soil exposed to erosion by wind, rain, runoff, and vehicle tracking.

Conditions of Use

The construction sequence schedule is an orderly listing of all major land-disturbing activities together with the necessary erosion and sedimentation control measures

planned for the project. This type of schedule guides the contractor on work to be done before other work is started so that serious erosion and sedimentation problems can be avoided.

Following a specified work schedule that coordinates the timing of land-disturbing activities and the installation of control measures is perhaps the most cost-effective way of controlling erosion during construction. The removal of surface ground cover leaves a site vulnerable to accelerated erosion. Construction procedures that limit land clearing provide timely installation of erosion and sedimentation controls, and restore protective cover quickly can significantly reduce the erosion potential of a site.

Design Considerations

- Minimize construction during rainy periods.
- Schedule projects to disturb only small portions of the site at any one time. Complete grading as soon as possible. Immediately stabilize the disturbed portion before grading the next portion. Practice staged seeding in order to revegetate cut and fill slopes as the work progresses.

II-4.2 Runoff Conveyance and Treatment BMPs

This section contains the standards and specifications for Runoff Conveyance and Treatment BMPs. [Table II-4.2.1 Runoff Conveyance and Treatment BMPs by SWPPP Element \(p.327\)](#), below, shows the relationship of the BMPs in [II-4.2 Runoff Conveyance and Treatment BMPs](#) to the Construction Stormwater Pollution Prevention Plan (SWPPP) Elements described in [II-3.3.3 Step 3 - Construction SWPPP Development and Implementation \(p.236\)](#).

Table II-4.2.1 Runoff Conveyance and Treatment BMPs by SWPPP Element

BMP or Element Name	Element #3 Control Flow Rates	Element #4 Install Sediment Controls	Element #6 Protect Slopes	Element #7 Protect Drain Inlets	Element #8 Stabilize Channels and Outlets	Element #9 Control Pollutants	Element #10 Control De-Watering	Element #13 Protect Low Impact Development
BMP C200: Interceptor Dike and Swale (p.331)			✓					✓

**Table II-4.2.1 Runoff Conveyance and Treatment BMPs by SWPPP
Element (continued)**

BMP or Element Name	Element #3 Control Flow Rates	Element #4 Install Sediment Controls	Element #6 Protect Slopes	Element #7 Protect Drain Inlets	Element #8 Stabilize Channels and Outlets	Element #9 Control Pollutants	Element #10 Control De-Watering	Element #13 Protect Low Impact Development
for High pH Water (p.412)								

BMP C200: Interceptor Dike and Swale

Purpose

Provide a ridge of compacted soil, or a ridge with an upslope swale, at the top or base of a disturbed slope or along the perimeter of a disturbed construction area to convey stormwater. Use the dike and/or swale to intercept the runoff from unprotected areas and direct it to areas where erosion can be controlled. This can prevent storm runoff from entering the work area or sediment-laden runoff from leaving the construction site.

Conditions of Use

Where the runoff from an exposed site or disturbed slope must be conveyed to an erosion control facility which can safely convey the stormwater.

- Locate upslope of a construction site to prevent runoff from entering disturbed area.
- When placed horizontally across a disturbed slope, it reduces the amount and velocity of runoff flowing down the slope.
- Locate downslope to collect runoff from a disturbed area and direct water to a sediment basin.

Design and Installation Specifications

- Dike and/or swale and channel must be stabilized with temporary or permanent vegetation or other channel protection during construction.
- Channel requires a positive grade for drainage; steeper grades require channel protection and check dams.
- Review construction for areas where overtopping may occur.
- Can be used at top of new fill before vegetation is established.

- May be used as a permanent diversion channel to carry the runoff.
- Sub-basin tributary area should be one acre or less.
- Design capacity for the peak volumetric flow rate calculated using a 10-minute time step from a 10-year, 24-hour storm, assuming a Type 1A rainfall distribution, for temporary facilities. Alternatively, use 1.6 times the 10-year, 1-hour flow indicated by an approved continuous runoff model. For facilities that will also serve on a permanent basis, consult the local government's drainage requirements.

Interceptor dikes shall meet the following criteria:

- Top Width: 2 feet minimum.
- Height: 1.5 feet minimum on berm.
- Side Slope: 2H:1V or flatter.
- Grade: Depends on topography, however, dike system minimum is 0.5%, and maximum is 1%.
- Compaction: Minimum of 90 percent ASTM D698 standard proctor.
- Horizontal Spacing of Interceptor Dikes:

Average Slope	Slope Percent	Flowpath Length
20H:1V or less	3-5%	300 feet
(10 to 20)H:1V	5-10%	200 feet
(4 to 10)H:1V	10-25%	100 feet
(2 to 4)H:1V	25-50%	50 feet

- Stabilization: depends on velocity and reach
- Slopes <5%: Seed and mulch applied within 5 days of dike construction (see [BMP C121: Mulching \(p.284\)](#)).
- Slopes 5 - 40%: Dependent on runoff velocities and dike materials. Stabilization should be done immediately using either sod or riprap or other measures to avoid erosion.
- The upslope side of the dike shall provide positive drainage to the dike outlet. No erosion shall occur at the outlet. Provide energy dissipation measures as necessary. Sediment-laden runoff must be released through a sediment trapping facility.
- Minimize construction traffic over temporary dikes. Use temporary cross culverts for channel crossing.

Interceptor swales shall meet the following criteria:

- Bottom Width: 2 feet minimum; the cross-section bottom shall be level.
- Depth: 1-foot minimum.

- Side Slope: 2H:1V or flatter.
- Grade: Maximum 5 percent, with positive drainage to a suitable outlet (such as a sediment pond).
- Stabilization: Seed as per [BMP C120: Temporary and Permanent Seeding \(p.278\)](#), or [BMP C202: Channel Lining \(p.338\)](#), 12 inches thick riprap pressed into the bank and extending at least 8 inches vertical from the bottom.

Inspect diversion dikes and interceptor swales once a week and after every rainfall. Immediately remove sediment from the flow area.

Damage caused by construction traffic or other activity must be repaired before the end of each working day.

Check outlets and make timely repairs as needed to avoid gully formation. When the area below the temporary diversion dike is permanently stabilized, remove the dike and fill and stabilize the channel to blend with the natural surface.

BMP C201: Grass-Lined Channels

Purpose

To provide a channel with a vegetative lining for conveyance of runoff. See [Figure II-4.2.1 Typical Grass-Lined Channels \(p.336\)](#) for typical grass-lined channels.

Conditions of Use

This practice applies to construction sites where concentrated runoff needs to be contained to prevent erosion or flooding.

- When a vegetative lining can provide sufficient stability for the channel cross section and at lower velocities of water (normally dependent on grade). This means that the channel slopes are generally less than 5 percent and space is available for a relatively large cross section.
- Typical uses include roadside ditches, channels at property boundaries, outlets for diversions, and other channels and drainage ditches in low areas.
- Channels that will be vegetated should be installed before major earthwork and hydroseeded with a bonded fiber matrix (BFM). The vegetation should be well established (i.e., 75 percent cover) before water is allowed to flow in the ditch. With channels that will have high flows, erosion control blankets should be installed over the hydroseed. If vegetation cannot be established from seed before water is allowed in the ditch, sod should be installed in the bottom of the ditch in lieu of hydromulch and blankets.

Design and Installation Specifications

Locate the channel where it can conform to the topography and other features such as roads.

- Locate them to use natural drainage systems to the greatest extent possible.
- Avoid sharp changes in alignment or bends and changes in grade.
- Do not reshape the landscape to fit the drainage channel.
- The maximum design velocity shall be based on soil conditions, type of vegetation, and method of revegetation, but at no times shall velocity exceed 5 feet/second. The channel shall not be overtopped by the peak volumetric flow rate calculated using a 10-minute time step from a 10-year, 24-hour storm, assuming a Type 1A rainfall distribution. Alternatively, use 1.6 times the 10-year, 1-hour flow indicated by an approved continuous runoff model to determine a flow rate which the channel must contain.
- Where the grass-lined channel will also function as a permanent stormwater conveyance facility, consult the drainage conveyance requirements of the local government with jurisdiction.
- An established grass or vegetated lining is required before the channel can be used to convey stormwater, unless stabilized with nets or blankets.
- If design velocity of a channel to be vegetated by seeding exceeds 2 ft/sec, a temporary channel liner is required. Geotextile or special mulch protection such as fiberglass roving or straw and netting provides stability until the vegetation is fully established. See [Figure II-4.2.2 Temporary Channel Liners \(p.337\)](#).
- Check dams shall be removed when the grass has matured sufficiently to protect the ditch or swale unless the slope of the swale is greater than 4 percent. The area beneath the check dams shall be seeded and mulched immediately after dam removal.
- If vegetation is established by sodding, the permissible velocity for established vegetation may be used and no temporary liner is needed.
- Do not subject grass-lined channel to sedimentation from disturbed areas. Use sediment-trapping BMPs upstream of the channel.
- V-shaped grass channels generally apply where the quantity of water is small, such as in short reaches along roadsides. The V-shaped cross section is least desirable because it is difficult to stabilize the bottom where velocities may be high.
- Trapezoidal grass channels are used where runoff volumes are large and slope is low so that velocities are nonerosive to vegetated linings. (Note: it is difficult to

construct small parabolic shaped channels.)

- Subsurface drainage, or riprap channel bottoms, may be necessary on sites that are subject to prolonged wet conditions due to long duration flows or a high water table.
- Provide outlet protection at culvert ends and at channel intersections.
- Grass channels, at a minimum, should carry peak runoff for temporary construction drainage facilities from the 10-year, 24-hour storm without eroding. Where flood hazard exists, increase the capacity according to the potential damage.
- Grassed channel side slopes generally are constructed 3H:1V or flatter to aid in the establishment of vegetation and for maintenance.
- Construct channels a minimum of 0.2 foot larger around the periphery to allow for soil bulking during seedbed preparations and sod buildup.

Maintenance Standards

During the establishment period, check grass-lined channels after every rainfall.

- After grass is established, periodically check the channel; check it after every heavy rainfall event. Immediately make repairs.
- It is particularly important to check the channel outlet and all road crossings for bank stability and evidence of piping or scour holes.
- Remove all significant sediment accumulations to maintain the designed carrying capacity. Keep the grass in a healthy, vigorous condition at all times, since it is the primary erosion protection for the channel.

Figure II-4.2.1 Typical Grass-Lined Channels

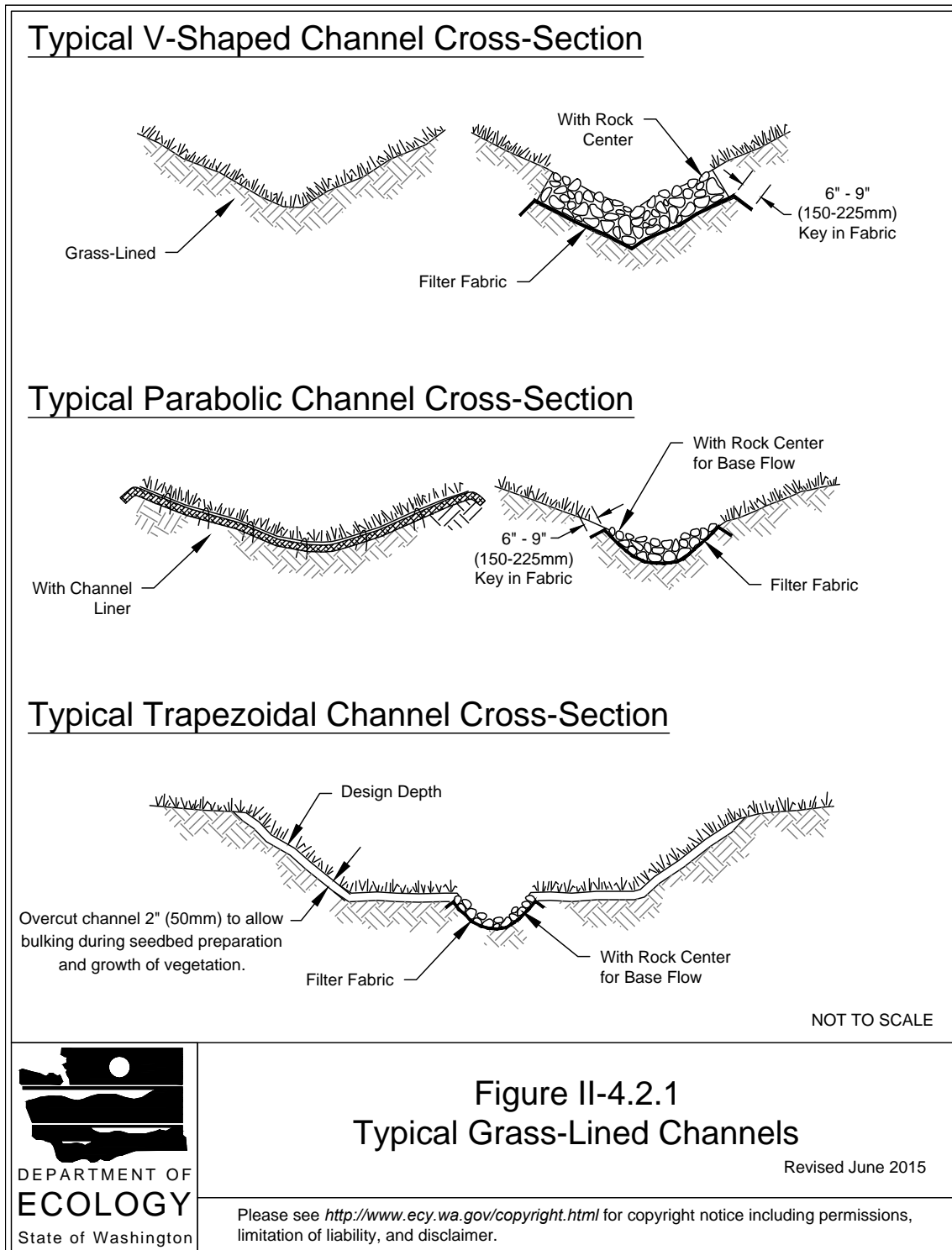
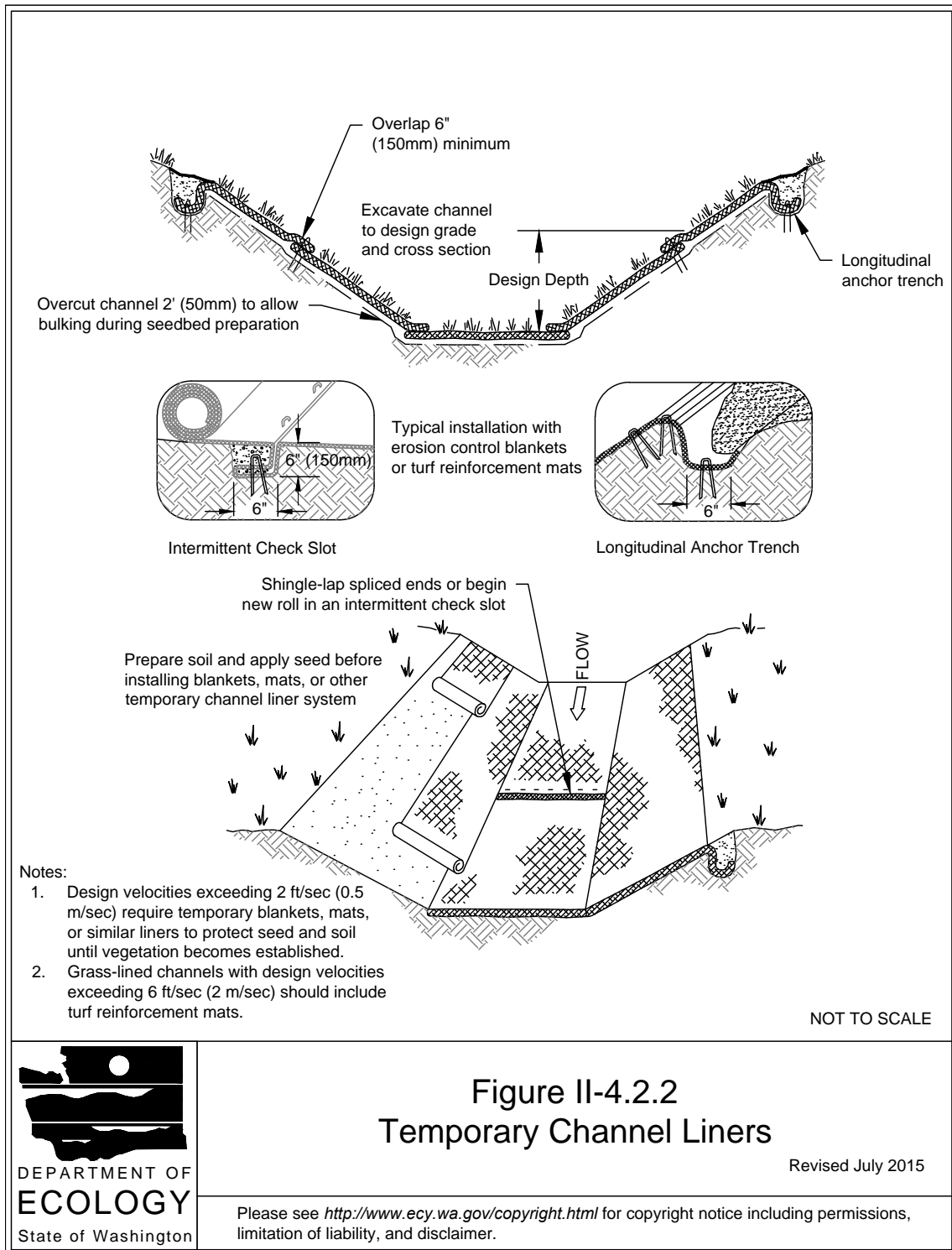

Figure II-4.2.2 Temporary Channel Liners



**Figure II-4.2.2
Temporary Channel Liners**

Revised July 2015

Please see <http://www.ecy.wa.gov/copyright.html> for copyright notice including permissions, limitation of liability, and disclaimer.

BMP C202: Channel Lining

Purpose

To protect channels by providing a channel liner using either blankets or riprap.

Conditions of Use

When natural soils or vegetated stabilized soils in a channel are not adequate to prevent channel erosion.

- When a permanent ditch or pipe system is to be installed and a temporary measure is needed.
- In almost all cases, synthetic and organic coconut blankets are more effective than riprap for protecting channels from erosion. Blankets can be used with and without vegetation. Blanketed channels can be designed to handle any expected flow and longevity requirement. Some synthetic blankets have a predicted life span of 50 years or more, even in sunlight.
- Other reasons why blankets are better than rock include the availability of blankets over rock. In many areas of the state, rock is not easily obtainable or is very expensive to haul to a site. Blankets can be delivered anywhere. Rock requires the use of dump trucks to haul and heavy equipment to place. Blankets usually only require laborers with hand tools, and sometimes a backhoe.
- The Federal Highway Administration recommends not using flexible liners whenever the slope exceeds 10 percent or the shear stress exceeds 8 lbs/ft².

Design and Installation Specifications

See [BMP C122: Nets and Blankets \(p.288\)](#) for information on blankets.

Since riprap is used where erosion potential is high, construction must be sequenced so that the riprap is put in place with the minimum possible delay.

- Disturbance of areas where riprap is to be placed should be undertaken only when final preparation and placement of the riprap can follow immediately behind the initial disturbance. Where riprap is used for outlet protection, the riprap should be placed before or in conjunction with the construction of the pipe or channel so that it is in place when the pipe or channel begins to operate.
- The designer, after determining the riprap size that will be stable under the flow conditions, shall consider that size to be a minimum size and then, based on riprap gradations actually available in the area, select the size or sizes that equal or exceed the minimum size. The possibility of drainage structure damage by children shall be considered in selecting a riprap size, especially if there is nearby water or a gully in which to toss the stones.

BMP C207: Check Dams

Purpose

Construction of small dams across a swale or ditch reduces the velocity of concentrated flow and dissipates energy at the check dam.

Conditions of Use

Where temporary channels or permanent channels are not yet vegetated, channel lining is infeasible, and/or velocity checks are required.

- Check dams may not be placed in streams unless approved by the State Department of Fish and Wildlife. Check dams may not be placed in wetlands without approval from a permitting agency.
- Do not place check dams below the expected backwater from any salmonid bearing water between October 1 and May 31 to ensure that there is no loss of high flow refuge habitat for overwintering juvenile salmonids and emergent salmonid fry.
- Construct rock check dams from appropriately sized rock. The rock used must be large enough to stay in place given the expected design flow through the channel. The rock must be placed by hand or by mechanical means (no dumping of rock to form dam) to achieve complete coverage of the ditch or swale and to ensure that the center of the dam is lower than the edges.
- Check dams may also be constructed of either rock or pea-gravel filled bags. Numerous new products are also available for this purpose. They tend to be reusable, quick and easy to install, effective, and cost efficient.
- Place check dams perpendicular to the flow of water.
- The dam should form a triangle when viewed from the side. This prevents undercutting as water flows over the face of the dam rather than falling directly onto the ditch bottom.
- Before installing check dams impound and bypass upstream water flow away from the work area. Options for bypassing include pumps, siphons, or temporary channels.
- Check dams in association with sumps work more effectively at slowing flow and retaining sediment than just a check dam alone. A deep sump should be provided immediately upstream of the check dam.
- In some cases, if carefully located and designed, check dams can remain as permanent installations with very minor regrading. They may be left as either spillways, in which case accumulated sediment would be graded and seeded, or as

check dams to prevent further sediment from leaving the site.

- The maximum spacing between the dams shall be such that the toe of the upstream dam is at the same elevation as the top of the downstream dam.
- Keep the maximum height at 2 feet at the center of the dam.
- Keep the center of the check dam at least 12 inches lower than the outer edges at natural ground elevation.
- Keep the side slopes of the check dam at 2H:1V or flatter.
- Key the stone into the ditch banks and extend it beyond the abutments a minimum of 18 inches to avoid washouts from overflow around the dam.
- Use filter fabric foundation under a rock or sand bag check dam. If a blanket ditch liner is used, filter fabric is not necessary. A piece of organic or synthetic blanket cut to fit will also work for this purpose.
- In the case of grass-lined ditches and swales, all check dams and accumulated sediment shall be removed when the grass has matured sufficiently to protect the ditch or swale - unless the slope of the swale is greater than 4 percent. The area beneath the check dams shall be seeded and mulched immediately after dam removal.
- Ensure that channel appurtenances, such as culvert entrances below check dams, are not subject to damage or blockage from displaced stones. [Figure II-4.2.7 Rock Check Dam \(p.354\)](#) depicts a typical rock check dam.

Maintenance Standards

Check dams shall be monitored for performance and sediment accumulation during and after each runoff producing rainfall. Sediment shall be removed when it reaches one half the sump depth.

- Anticipate submergence and deposition above the check dam and erosion from high flows around the edges of the dam.
- If significant erosion occurs between dams, install a protective riprap liner in that portion of the channel.

Approved as Equivalent

Ecology has approved products as able to meet the requirements of [BMP C207: Check Dams](#). The products did not pass through the Technology Assessment Protocol – Ecology (TAPE) process. Local jurisdictions may choose not to accept this product approved as equivalent, or may require additional testing prior to consideration for local use. The products are available for review on Ecology’s website at <http://www.ecy.wa.gov/programs/wq/stormwater/newtech/equivalent.html>

Figure II-4.2.7 Rock Check Dam

View Looking Upstream

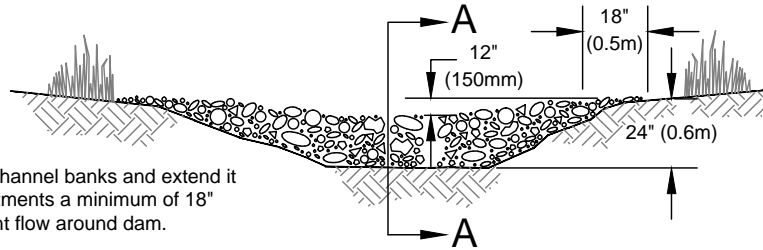

Note:
Key stone into channel banks and extend it beyond the abutments a minimum of 18" (0.5m) to prevent flow around dam.

Section A-A

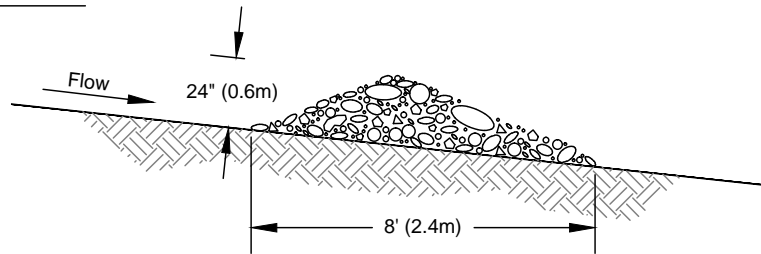

Spacing Between Check Dams

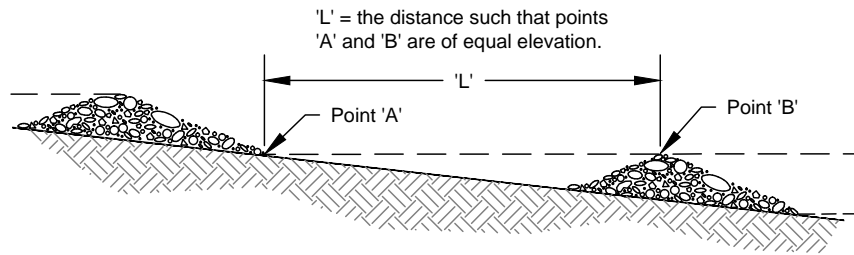

NOT TO SCALE



**Figure II-4.2.7
Rock Check Dam**

Revised July 2015

Please see <http://www.ecy.wa.gov/copyright.html> for copyright notice including permissions, limitation of liability, and disclaimer.

- In the case of grass-lined ditches and swales, check dams and accumulated sediment shall be removed when the grass has matured sufficiently to protect the ditch or swale unless the slope of the swale is greater than 4 percent. The area beneath the check dams shall be seeded and mulched immediately after dam removal.

Maintenance Standards

- Triangular silt dams shall be inspected for performance and sediment accumulation during and after each runoff producing rainfall. Sediment shall be removed when it reaches one half the height of the dam.
- Anticipate submergence and deposition above the triangular silt dam and erosion from high flows around the edges of the dam. Immediately repair any damage or any undercutting of the dam.

BMP C209: Outlet Protection

Purpose

Outlet protection prevents scour at conveyance outlets and minimizes the potential for downstream erosion by reducing the velocity of concentrated stormwater flows.

Conditions of Use

Outlet protection is required at the outlets of all ponds, pipes, ditches, or other conveyances, and where runoff is conveyed to a natural or manmade drainage feature such as a stream, wetland, lake, or ditch.

Design and Installation Specifications

The receiving channel at the outlet of a culvert shall be protected from erosion by rock lining a minimum of 6 feet downstream and extending up the channel sides a minimum of 1-foot above the maximum tailwater elevation or 1-foot above the crown, whichever is higher. For large pipes (more than 18 inches in diameter), the outlet protection lining of the channel is lengthened to four times the diameter of the culvert.

- Standard wingwalls, and tapered outlets and paved channels should also be considered when appropriate for permanent culvert outlet protection. (See WSDOT Hydraulic Manual, available through WSDOT Engineering Publications).
- Organic or synthetic erosion blankets, with or without vegetation, are usually more effective than rock, cheaper, and easier to install. Materials can be chosen using manufacturer product specifications. ASTM test results are available for most products and the designer can choose the correct material for the expected flow.
- With low flows, vegetation (including sod) can be effective.
- The following guidelines shall be used for riprap outlet protection:

1. If the discharge velocity at the outlet is less than 5 fps (pipe slope less than 1 percent), use 2-inch to 8-inch riprap. Minimum thickness is 1-foot.
 2. For 5 to 10 fps discharge velocity at the outlet (pipe slope less than 3 percent), use 24-inch to 48-inch riprap. Minimum thickness is 2 feet.
 3. For outlets at the base of steep slope pipes (pipe slope greater than 10 percent), an engineered energy dissipater shall be used.
- Filter fabric or erosion control blankets should always be used under riprap to prevent scour and channel erosion.
 - New pipe outfalls can provide an opportunity for low-cost fish habitat improvements. For example, an alcove of low-velocity water can be created by constructing the pipe outfall and associated energy dissipater back from the stream edge and digging a channel, over-widened to the upstream side, from the outfall. Overwintering juvenile and migrating adult salmonids may use the alcove as shelter during high flows. Bank stabilization, bioengineering, and habitat features may be required for disturbed areas. This work may require a HPA. See [Volume V \(p.765\)](#) for more information on outfall system design.

Maintenance Standards

- Inspect and repair as needed.
- Add rock as needed to maintain the intended function.
- Clean energy dissipater if sediment builds up.

BMP C220: Storm Drain Inlet Protection

Purpose

Storm drain inlet protection prevents coarse sediment from entering drainage systems prior to permanent stabilization of the disturbed area.

Conditions of Use

Use storm drain inlet protection at inlets that are operational before permanent stabilization of the disturbed drainage area. Provide protection for all storm drain inlets downslope and within 500 feet of a disturbed or construction area, unless conveying runoff entering catch basins to a sediment pond or trap.

Also consider inlet protection for lawn and yard drains on new home construction. These small and numerous drains coupled with lack of gutters in new home construction can add significant amounts of sediment into the roof drain system. If possible delay installing lawn and yard drains until just before landscaping or cap these drains to pre-

vent sediment from entering the system until completion of landscaping. Provide 18-inches of sod around each finished lawn and yard drain.

[Table II-4.2.2 Storm Drain Inlet Protection \(p.358\)](#) lists several options for inlet protection. All of the methods for storm drain inlet protection tend to plug and require a high frequency of maintenance. Limit drainage areas to one acre or less. Possibly provide emergency overflows with additional end-of-pipe treatment where stormwater ponding would cause a hazard.

Table II-4.2.2 Storm Drain Inlet Protection

Type of Inlet Protection	Emergency Overflow	Applicable for Paved/ Earthen Surfaces	Conditions of Use
Drop Inlet Protection			
Excavated drop inlet protection	Yes, temporary flooding will occur	Earthen	Applicable for heavy flows. Easy to maintain. Large area Requirement: 30'x30'/acre
Block and gravel drop inlet protection	Yes	Paved or Earthen	Applicable for heavy concentrated flows. Will not pond.
Gravel and wire drop inlet protection	No		Applicable for heavy concentrated flows. Will pond. Can withstand traffic.
Catch basin filters	Yes	Paved or Earthen	Frequent Maintenance required.
Curb Inlet Protection			
Curb inlet protection with wooden weir	Small capacity overflow	Paved	Used for sturdy, more compact installation.
Block and gravel curb inlet protection	Yes	Paved	Sturdy, but limited filtration.
Culvert Inlet Protection			
Culvert inlet Sediment trap			18 month expected life.

Design and Installation Specifications

Excavated Drop Inlet Protection - An excavated impoundment around the storm drain. Sediment settles out of the stormwater prior to entering the storm drain.

- Provide a depth of 1-2 ft as measured from the crest of the inlet structure.
- Slope sides of excavation no steeper than 2H:1V.
- Minimum volume of excavation 35 cubic yards.
- Shape basin to fit site with longest dimension oriented toward the longest inflow area.
- Install provisions for draining to prevent standing water problems.
- Clear the area of all debris.
- Grade the approach to the inlet uniformly.
- Drill weep holes into the side of the inlet.
- Protect weep holes with screen wire and washed aggregate.
- Seal weep holes when removing structure and stabilizing area.
- Build a temporary dike, if necessary, to the down slope side of the structure to prevent bypass flow.

Block and Gravel Filter - A barrier formed around the storm drain inlet with standard concrete blocks and gravel. See [Figure II-4.2.8 Block and Gravel Filter \(p.360\)](#).

- Provide a height of 1 to 2 feet above inlet.
- Recess the first row 2-inches into the ground for stability.
- Support subsequent courses by placing a 2x4 through the block opening.
- Do not use mortar.
- Lay some blocks in the bottom row on their side for dewatering the pool.
- Place hardware cloth or comparable wire mesh with ½-inch openings over all block openings.
- Place gravel just below the top of blocks on slopes of 2H:1V or flatter.
- An alternative design is a gravel donut.
- Provide an inlet slope of 3H:1V.
- Provide an outlet slope of 2H:1V.
- Provide a 1-foot wide level stone area between the structure and the inlet.
- Use inlet slope stones 3 inches in diameter or larger.
- Use gravel ½- to ¾-inch at a minimum thickness of 1-foot for the outlet slope.

Figure II-4.2.8 Block and Gravel Filter

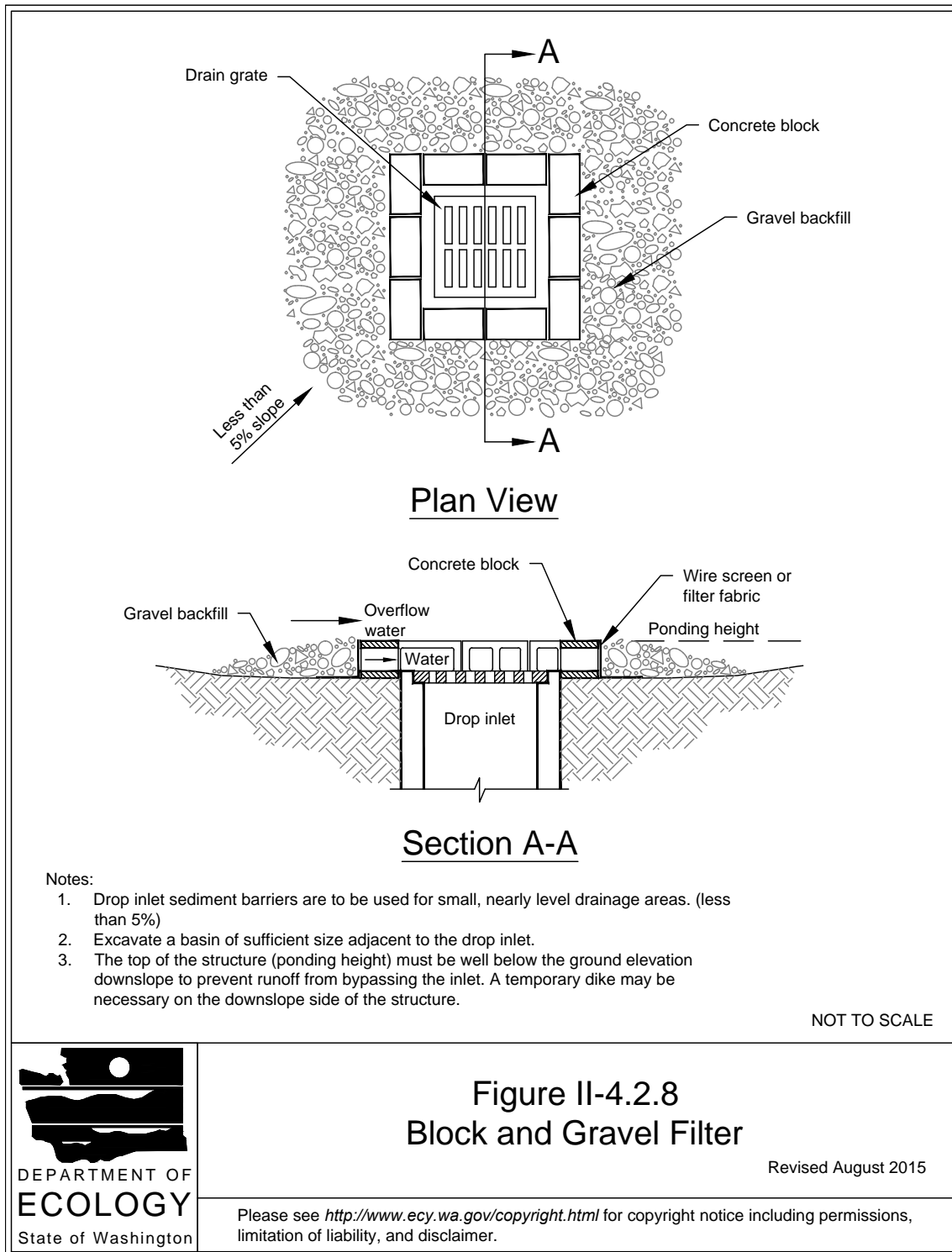

**Figure II-4.2.8
Block and Gravel Filter**

Revised August 2015

Please see <http://www.ecy.wa.gov/copyright.html> for copyright notice including permissions, limitation of liability, and disclaimer.

Gravel and Wire Mesh Filter - A gravel barrier placed over the top of the inlet. This structure does not provide an overflow.

- Use a hardware cloth or comparable wire mesh with ½-inch openings.
- Use coarse aggregate.
- Provide a height 1-foot or more, 18-inches wider than inlet on all sides.
- Place wire mesh over the drop inlet so that the wire extends a minimum of 1-foot beyond each side of the inlet structure.
- Overlap the strips if more than one strip of mesh is necessary.
- Place coarse aggregate over the wire mesh.
- Provide at least a 12-inch depth of gravel over the entire inlet opening and extend at least 18-inches on all sides.

Catchbasin Filters – Use inserts designed by manufacturers for construction sites. The limited sediment storage capacity increases the amount of inspection and maintenance required, which may be daily for heavy sediment loads. To reduce maintenance requirements combine a catchbasin filter with another type of inlet protection. This type of inlet protection provides flow bypass without overflow and therefore may be a better method for inlets located along active rights-of-way.

- Provides 5 cubic feet of storage.
- Requires dewatering provisions.
- Provides a high-flow bypass that will not clog under normal use at a construction site.
- Insert the catchbasin filter in the catchbasin just below the grating.

Curb Inlet Protection with Wooden Weir – Barrier formed around a curb inlet with a wooden frame and gravel.

- Use wire mesh with ½-inch openings.
- Use extra strength filter cloth.
- Construct a frame.
- Attach the wire and filter fabric to the frame.
- Pile coarse washed aggregate against wire/fabric.
- Place weight on frame anchors.

Block and Gravel Curb Inlet Protection – Barrier formed around a curb inlet with concrete blocks and gravel. See [Figure II-4.2.9 Block and Gravel Curb Inlet Protection \(p.363\)](#).

- Use wire mesh with ½-inch openings.
- Place two concrete blocks on their sides abutting the curb at either side of the inlet opening. These are spacer blocks.
- Place a 2x4 stud through the outer holes of each spacer block to align the front blocks.
- Place blocks on their sides across the front of the inlet and abutting the spacer blocks.
- Place wire mesh over the outside vertical face.
- Pile coarse aggregate against the wire to the top of the barrier.

Curb and Gutter Sediment Barrier – Sandbag or rock berm (riprap and aggregate) 3 feet high and 3 feet wide in a horseshoe shape. See [Figure II-4.2.10 Curb and Gutter Barrier \(p.364\)](#).

- Construct a horseshoe shaped berm, faced with coarse aggregate if using riprap, 3 feet high and 3 feet wide, at least 2 feet from the inlet.
- Construct a horseshoe shaped sedimentation trap on the outside of the berm sized to sediment trap standards for protecting a culvert inlet.

Maintenance Standards

- Inspect catch basin filters frequently, especially after storm events. Clean and replace clogged inserts. For systems with clogged stone filters: pull away the stones from the inlet and clean or replace. An alternative approach would be to use the clogged stone as fill and put fresh stone around the inlet.
- Do not wash sediment into storm drains while cleaning. Spread all excavated material evenly over the surrounding land area or stockpile and stabilize as appropriate.

Approved as Equivalent

Ecology has approved products as able to meet the requirements of [BMP C220: Storm Drain Inlet Protection](#). The products did not pass through the Technology Assessment Protocol – Ecology (TAPE) process. Local jurisdictions may choose not to accept this product approved as equivalent, or may require additional testing prior to consideration for local use. The products are available for review on Ecology’s website at <http://www.ecy.wa.gov/programs/wq/stormwater/newtech/equivalent.html>

Figure II-4.2.9 Block and Gravel Curb Inlet Protection

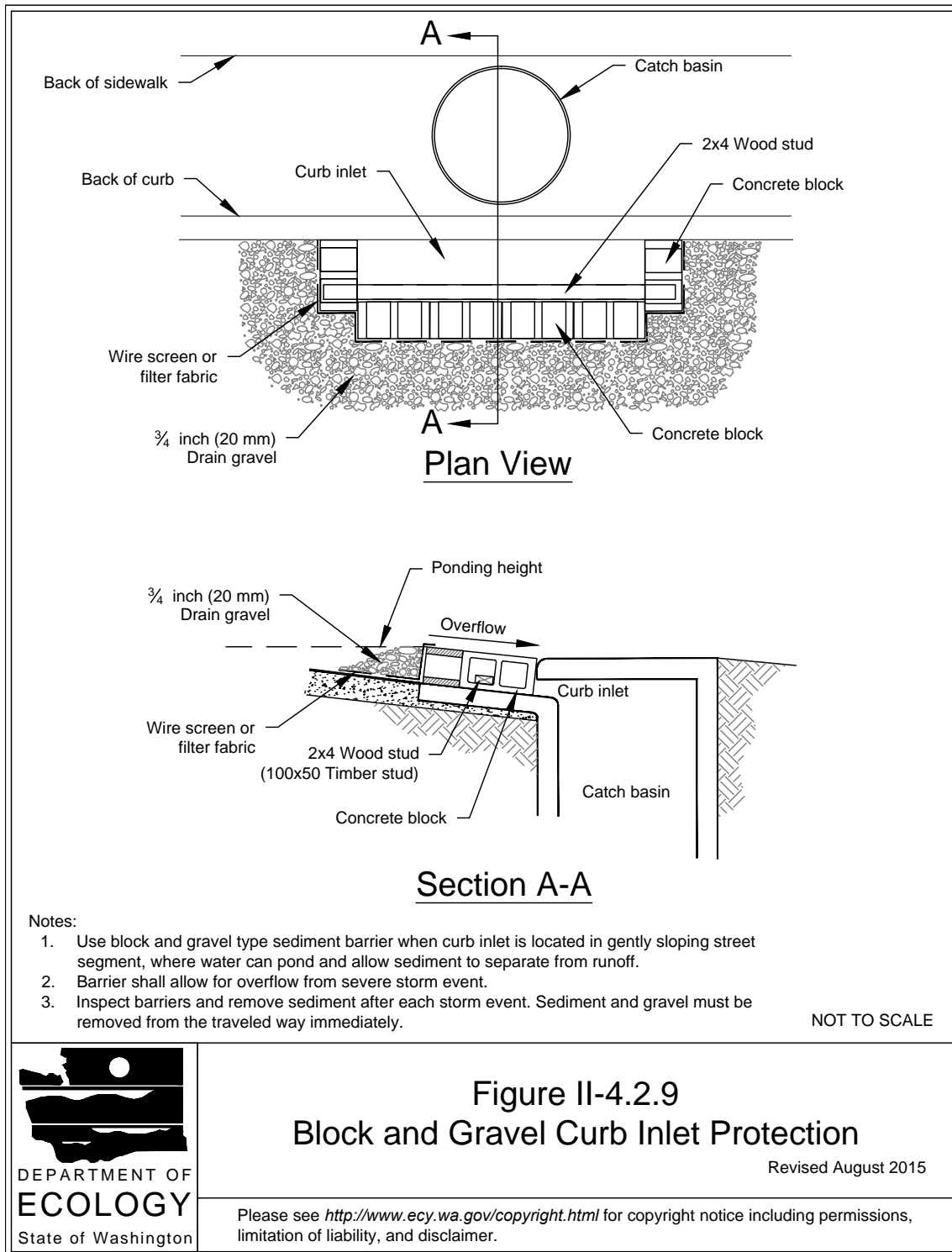
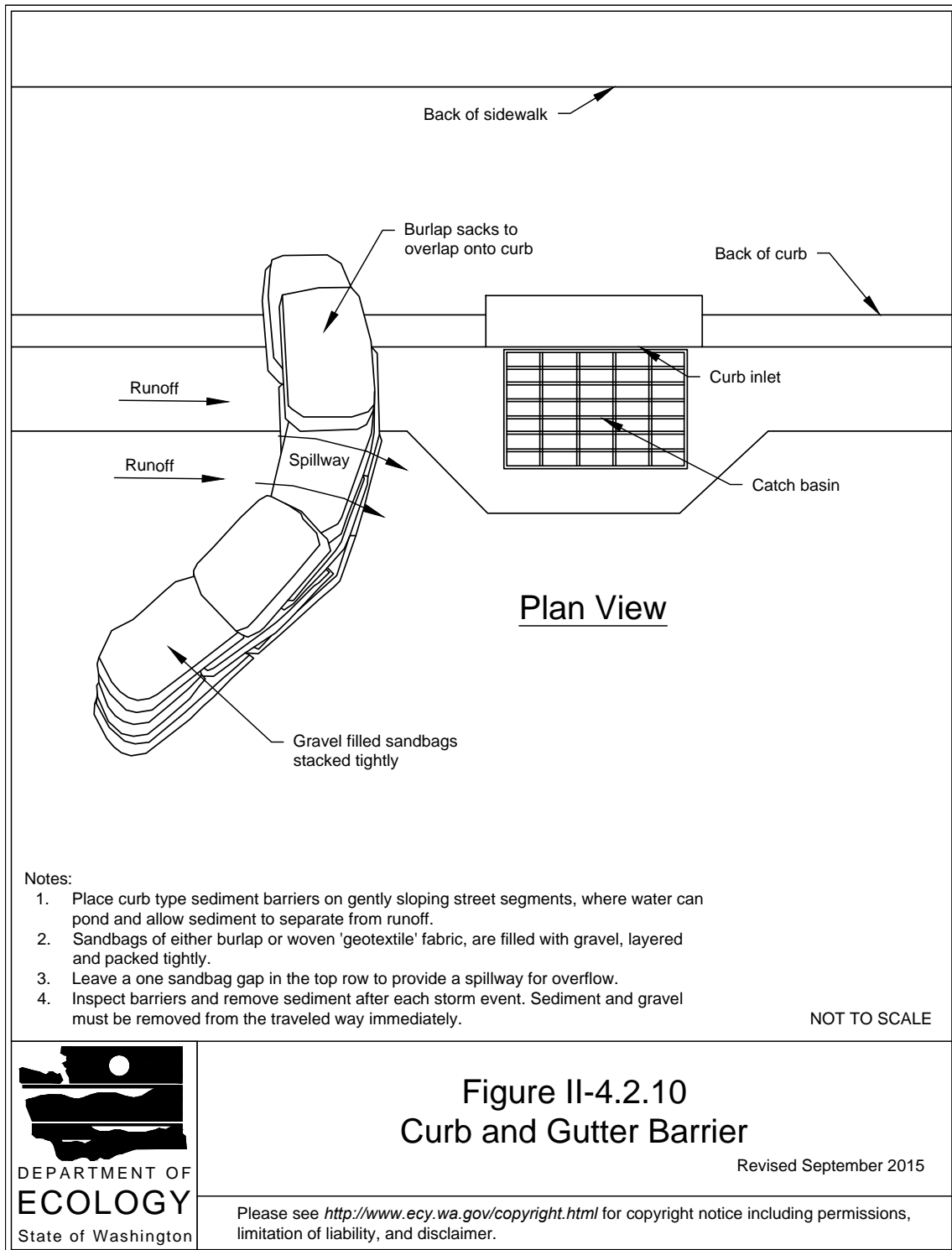

**Figure II-4.2.9
Block and Gravel Curb Inlet Protection**

Revised August 2015

Please see <http://www.ecy.wa.gov/copyright.html> for copyright notice including permissions, limitation of liability, and disclaimer.

Figure II-4.2.10 Curb and Gutter Barrier



**Figure II-4.2.10
Curb and Gutter Barrier**

Revised September 2015

Please see <http://www.ecy.wa.gov/copyright.html> for copyright notice including permissions, limitation of liability, and disclaimer.

BMP C232: Gravel Filter Berm

Purpose

A gravel filter berm is constructed on rights-of-way or traffic areas within a construction site to retain sediment by using a filter berm of gravel or crushed rock.

Conditions of Use

Where a temporary measure is needed to retain sediment from rights-of-way or in traffic areas on construction sites.

Design and Installation Specifications

- Berm material shall be $\frac{3}{4}$ to 3 inches in size, washed well-grade gravel or crushed rock with less than 5 percent fines.
- Spacing of berms:
 - Every 300 feet on slopes less than 5 percent
 - Every 200 feet on slopes between 5 percent and 10 percent
 - Every 100 feet on slopes greater than 10 percent
- Berm dimensions:
 - 1 foot high with 3H:1V side slopes
 - 8 linear feet per 1 cfs runoff based on the 10-year, 24-hour design storm

Maintenance Standards

- Regular inspection is required. Sediment shall be removed and filter material replaced as needed.

BMP C233: Silt Fence

Purpose

Use of a silt fence reduces the transport of coarse sediment from a construction site by providing a temporary physical barrier to sediment and reducing the runoff velocities of overland flow. See [Figure II-4.2.12 Silt Fence \(p.369\)](#) for details on silt fence construction.

Conditions of Use

Silt fence may be used downslope of all disturbed areas.

- Silt fence shall prevent soil carried by runoff water from going beneath, through, or over the top of the silt fence, but shall allow the water to pass through the fence.
- Silt fence is not intended to treat concentrated flows, nor is it intended to treat substantial amounts of overland flow. Convey any concentrated flows through the drainage system to a sediment pond.
- Do not construct silt fences in streams or use in V-shaped ditches. Silt fences do not provide an adequate method of silt control for anything deeper than sheet or overland flow.

Figure II-4.2.12 Silt Fence

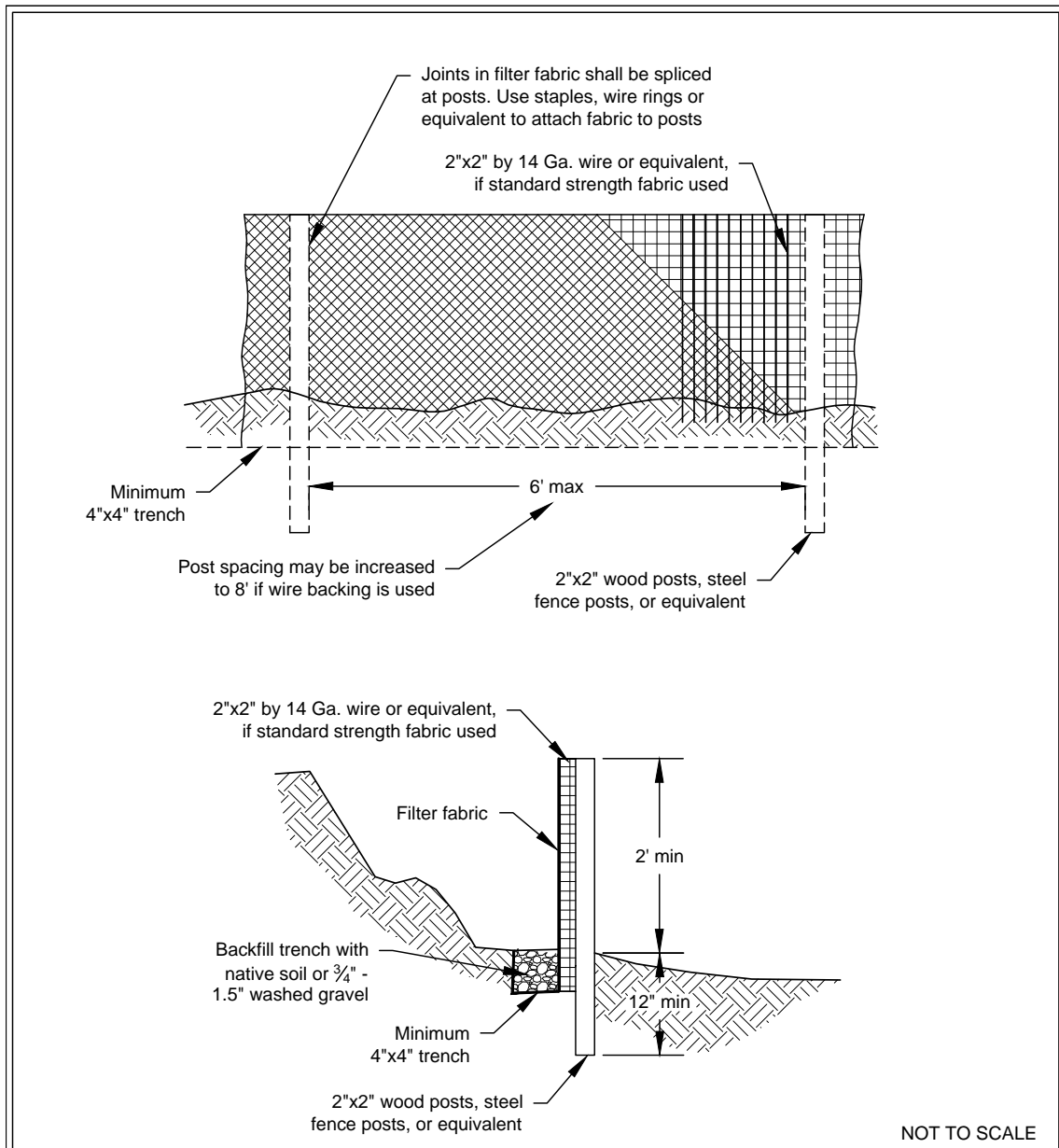

**Figure II-4.2.12
Silt Fence**

Revised October 2014

Please see <http://www.ecy.wa.gov/copyright.html> for copyright notice including permissions, limitation of liability, and disclaimer.

Design and Installation Specifications

- Use in combination with sediment basins or other BMPs.
- Maximum slope steepness (normal (perpendicular) to fence line) 1H:1V.
- Maximum sheet or overland flow path length to the fence of 100 feet.
- Do not allow flows greater than 0.5 cfs.
- The geotextile used shall meet the following standards. All geotextile properties listed below are minimum average roll values (i.e., the test result for any sampled roll in a lot shall meet or exceed the values shown in [Table II-4.2.3 Geotextile Standards \(p.370\)](#)):

Table II-4.2.3 Geotextile Standards

Polymeric Mesh AOS (ASTM D4751)	0.60 mm maximum for slit film woven (#30 sieve). 0.30 mm maximum for all other geotextile types (#50 sieve). 0.15 mm minimum for all fabric types (#100 sieve).
Water Permittivity (ASTM D4491)	0.02 sec ⁻¹ minimum
Grab Tensile Strength (ASTM D4632)	180 lbs. Minimum for extra strength fabric. 100 lbs minimum for standard strength fabric.
Grab Tensile Strength (ASTM D4632)	30% maximum
Ultraviolet Resistance (ASTM D4355)	70% minimum

- Support standard strength fabrics with wire mesh, chicken wire, 2-inch x 2-inch wire, safety fence, or jute mesh to increase the strength of the fabric. Silt fence materials are available that have synthetic mesh backing attached.
- Filter fabric material shall contain ultraviolet ray inhibitors and stabilizers to provide a minimum of six months of expected usable construction life at a temperature range of 0°F. to 120°F.
- One-hundred percent biodegradable silt fence is available that is strong, long lasting, and can be left in place after the project is completed, if permitted by local regulations.
- Refer to [Figure II-4.2.12 Silt Fence \(p.369\)](#) for standard silt fence details. Include the following standard Notes for silt fence on construction plans and specifications:

1. The contractor shall install and maintain temporary silt fences at the locations shown in the Plans.
2. Construct silt fences in areas of clearing, grading, or drainage prior to starting those activities.
3. The silt fence shall have a 2-foot min. and a 2½-foot max. height above the original ground surface.
4. The filter fabric shall be sewn together at the point of manufacture to form filter fabric lengths as required. Locate all sewn seams at support posts. Alternatively, two sections of silt fence can be overlapped, provided the Contractor can demonstrate, to the satisfaction of the Engineer, that the overlap is long enough and that the adjacent fence sections are close enough together to prevent silt laden water from escaping through the fence at the overlap.
5. Attach the filter fabric on the up-slope side of the posts and secure with staples, wire, or in accordance with the manufacturer's recommendations. Attach the filter fabric to the posts in a manner that reduces the potential for tearing.
6. Support the filter fabric with wire or plastic mesh, dependent on the properties of the geotextile selected for use. If wire or plastic mesh is used, fasten the mesh securely to the up-slope side of the posts with the filter fabric up-slope of the mesh.
7. Mesh support, if used, shall consist of steel wire with a maximum mesh spacing of 2-inches, or a prefabricated polymeric mesh. The strength of the wire or polymeric mesh shall be equivalent to or greater than 180 lbs. grab tensile strength. The polymeric mesh must be as resistant to the same level of ultra-violet radiation as the filter fabric it supports.
8. Bury the bottom of the filter fabric 4-inches min. below the ground surface. Backfill and tamp soil in place over the buried portion of the filter fabric, so that no flow can pass beneath the fence and scouring cannot occur. When wire or polymeric back-up support mesh is used, the wire or polymeric mesh shall extend into the ground 3-inches min.
9. Drive or place the fence posts into the ground 18-inches min. A 12-inch min. depth is allowed if topsoil or other soft subgrade soil is not present and 18-inches cannot be reached. Increase fence post min. depths by 6 inches if the fence is located on slopes of 3H:1V or steeper and the slope is perpendicular to the fence. If required post depths cannot be obtained, the posts shall be adequately secured by bracing or guying to prevent overturning of the fence due to sediment loading.
10. Use wood, steel or equivalent posts. The spacing of the support posts shall

be a maximum of 6-feet. Posts shall consist of either:

- Wood with dimensions of 2-inches by 2-inches wide min. and a 3-foot min. length. Wood posts shall be free of defects such as knots, splits, or gouges.
 - No. 6 steel rebar or larger.
 - ASTM A 120 steel pipe with a minimum diameter of 1-inch.
 - U, T, L, or C shape steel posts with a minimum weight of 1.35 lbs./ft.
 - Other steel posts having equivalent strength and bending resistance to the post sizes listed above.
11. Locate silt fences on contour as much as possible, except at the ends of the fence, where the fence shall be turned uphill such that the silt fence captures the runoff water and prevents water from flowing around the end of the fence.
 12. If the fence must cross contours, with the exception of the ends of the fence, place gravel check dams perpendicular to the back of the fence to minimize concentrated flow and erosion. The slope of the fence line where contours must be crossed shall not be steeper than 3H:1V.
 - Gravel check dams shall be approximately 1-foot deep at the back of the fence. Gravel check dams shall be continued perpendicular to the fence at the same elevation until the top of the check dam intercepts the ground surface behind the fence.
 - Gravel check dams shall consist of crushed surfacing base course, gravel backfill for walls, or shoulder ballast. Gravel check dams shall be located every 10 feet along the fence where the fence must cross contours.
- Refer to [Figure II-4.2.13 Silt Fence Installation by Slicing Method \(p.374\)](#) for slicing method details. Silt fence installation using the slicing method specifications:
 1. The base of both end posts must be at least 2- to 4-inches above the top of the filter fabric on the middle posts for ditch checks to drain properly. Use a hand level or string level, if necessary, to mark base points before installation.
 2. Install posts 3- to 4-feet apart in critical retention areas and 6- to 7-feet apart in standard applications.
 3. Install posts 24-inches deep on the downstream side of the silt fence, and as close as possible to the filter fabric, enabling posts to support the filter fabric from upstream water pressure.
 4. Install posts with the nipples facing away from the filter fabric.

5. Attach the filter fabric to each post with three ties, all spaced within the top 8-inches of the filter fabric. Attach each tie diagonally 45 degrees through the filter fabric, with each puncture at least 1-inch vertically apart. Each tie should be positioned to hang on a post nipple when tightening to prevent sagging.
6. Wrap approximately 6-inches of fabric around the end posts and secure with 3 ties.
7. No more than 24-inches of a 36-inch filter fabric is allowed above ground level.

Compact the soil immediately next to the filter fabric with the front wheel of the tractor, skid steer, or roller exerting at least 60 pounds per square inch. Compact the upstream side first and then each side twice for a total of four trips. Check and correct the silt fence installation for any deviation before compaction. Use a flat-bladed shovel to tuck fabric deeper into the ground if necessary.

Figure II-4.2.13 Silt Fence Installation by Slicing Method

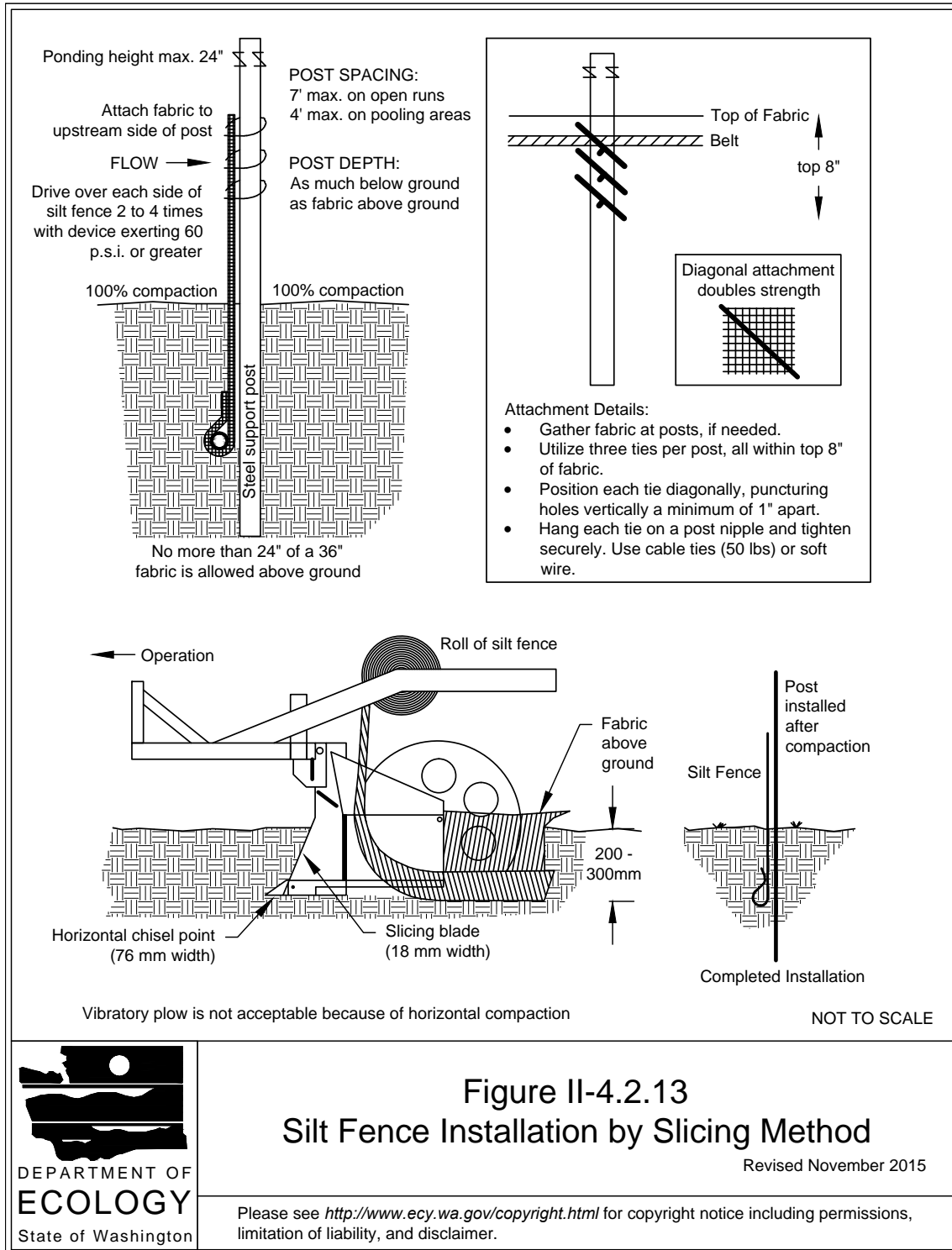

**Figure II-4.2.13
Silt Fence Installation by Slicing Method**

Revised November 2015



Please see <http://www.ecy.wa.gov/copyright.html> for copyright notice including permissions, limitation of liability, and disclaimer.

Design and Installation Specifications

- The vegetated strip shall consist of a minimum of a 25-foot flowpath length continuous strip of dense vegetation with topsoil. Grass-covered, landscaped areas are generally not adequate because the volume of sediment overwhelms the grass. Ideally, vegetated strips shall consist of undisturbed native growth with a well-developed soil that allows for infiltration of runoff.
- The slope within the strip shall not exceed 4H:1V.
- The uphill boundary of the vegetated strip shall be delineated with clearing limits.

Maintenance Standards

- Any areas damaged by erosion or construction activity shall be seeded immediately and protected by mulch.
- If more than 5 feet of the original vegetated strip width has had vegetation removed or is being eroded, sod must be installed.
- If there are indications that concentrated flows are traveling across the buffer, surface water controls must be installed to reduce the flows entering the buffer, or additional perimeter protection must be installed.

BMP C235: Wattles

Purpose

Wattles are temporary erosion and sediment control barriers consisting of straw, compost, or other material that is wrapped in biodegradable tubular plastic or similar encasing material. They reduce the velocity and can spread the flow of rill and sheet runoff, and can capture and retain sediment. Wattles are typically 8 to 10 inches in diameter and 25 to 30 feet in length. Wattles are placed in shallow trenches and staked along the contour of disturbed or newly constructed slopes. See [Figure II-4.2.14 Wattles \(p.378\)](#) for typical construction details. WSDOT Standard Plan I-30.30-00 also provides information on Wattles (<http://www.wsdot.wa.gov/Design/Standards/Plans.htm#SectionI>)

Conditions of Use

- Use wattles:
 - In disturbed areas that require immediate erosion protection.
 - On exposed soils during the period of short construction delays, or over winter months.
 - On slopes requiring stabilization until permanent vegetation can be established.

- The material used dictates the effectiveness period of the wattle. Generally, Wattles are typically effective for one to two seasons.
- Prevent rilling beneath wattles by properly entrenching and abutting wattles together to prevent water from passing between them.

Design Criteria

- Install wattles perpendicular to the flow direction and parallel to the slope contour.
- Narrow trenches should be dug across the slope on contour to a depth of 3- to 5- inches on clay soils and soils with gradual slopes. On loose soils, steep slopes, and areas with high rainfall, the trenches should be dug to a depth of 5- to 7- inches, or 1/2 to 2/3 of the thickness of the wattle.
- Start building trenches and installing wattles from the base of the slope and work up. Spread excavated material evenly along the uphill slope and compacted using hand tamping or other methods.
- Construct trenches at intervals of 10- to 25-feet depending on the steepness of the slope, soil type, and rainfall. The steeper the slope the closer together the trenches.
- Install the wattles snugly into the trenches and abut tightly end to end. Do not overlap the ends.
- Install stakes at each end of the wattle, and at 4-foot centers along entire length of wattle.
- If required, install pilot holes for the stakes using a straight bar to drive holes through the wattle and into the soil.
- Wooden stakes should be approximately 3/4 x 3/4 x 24 inches min. Willow cuttings or 3/8-inch rebar can also be used for stakes.
- Stakes should be driven through the middle of the wattle, leaving 2 to 3 inches of the stake protruding above the wattle.

Maintenance Standards

- Wattles may require maintenance to ensure they are in contact with soil and thoroughly entrenched, especially after significant rainfall on steep sandy soils.

Figure II-4.2.14 Wattles

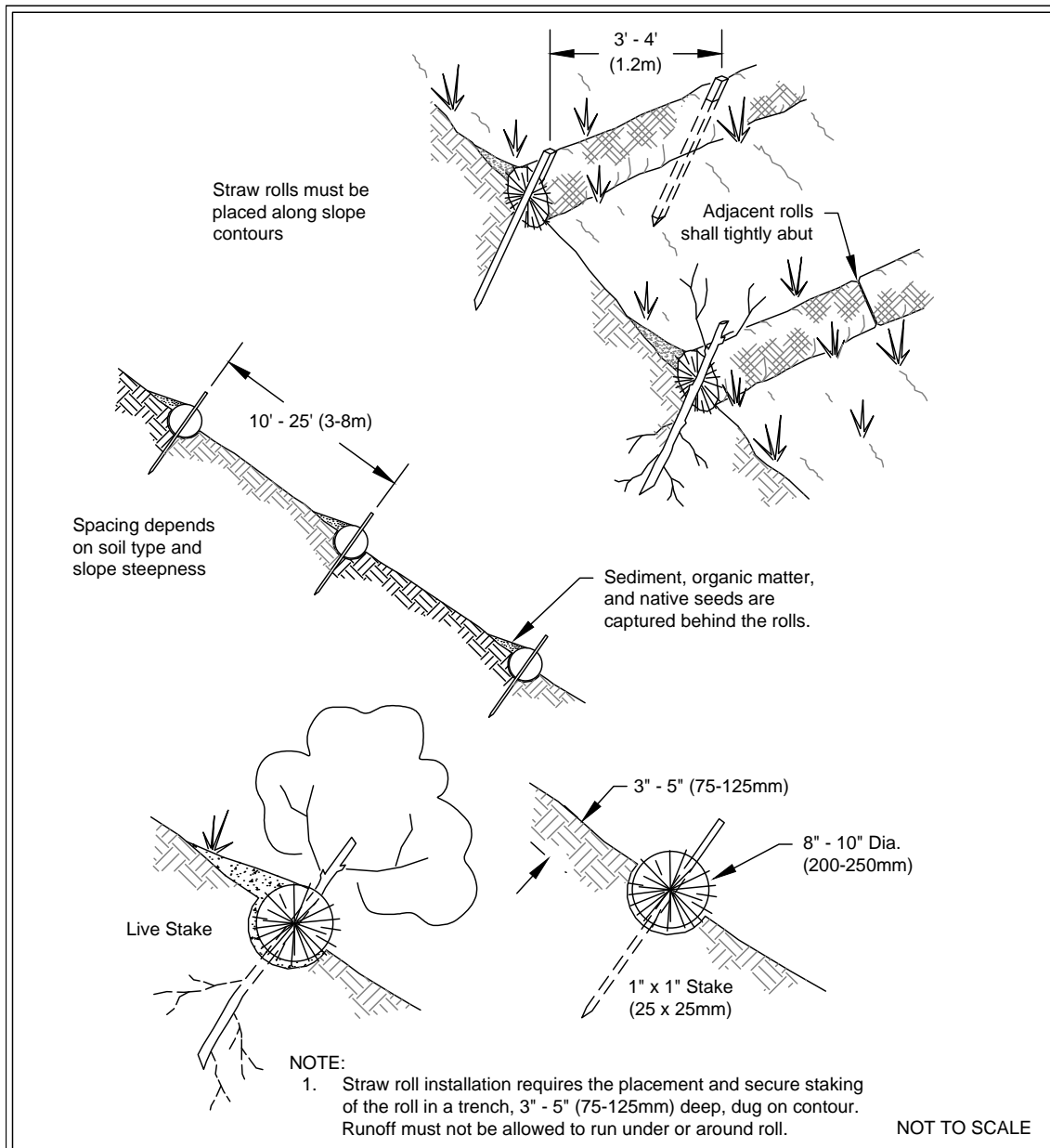

**Figure II-4.2.14
Wattles**

Revised November 2015

Please see <http://www.ecy.wa.gov/copyright.html> for copyright notice including permissions, limitation of liability, and disclaimer.

- Inspect the slope after significant storms and repair any areas where wattles are not tightly abutted or water has scoured beneath the wattles.

Approved as Equivalent

Ecology has approved products as able to meet the requirements of [BMP C235: Wattles](#). The products did not pass through the Technology Assessment Protocol – Ecology (TAPE) process. Local jurisdictions may choose not to accept this product approved as equivalent, or may require additional testing prior to consideration for local use. The products are available for review on Ecology’s website at <http://www.ecy.wa.gov/programs/wq/stormwater/newtech/equivalent.html>

BMP C236: Vegetative Filtration

Purpose

Vegetative Filtration may be used in conjunction with [BMP C241: Temporary Sediment Pond \(p.388\)](#), [BMP C206: Level Spreader \(p.348\)](#) and a pumping system with surface intake to improve turbidity levels of stormwater discharges by filtering through existing vegetation where undisturbed forest floor duff layer or established lawn with thatch layer are present. Vegetative Filtration can also be used to infiltrate dewatering waste from foundations, vaults, and trenches as long as runoff does not occur.

Conditions of Use

- For every five acre of disturbed soil use one acre of grass field, farm pasture, or wooded area. Reduce or increase this area depending on project size, ground water table height, and other site conditions.
- Wetlands shall not be used for filtration.
- Do not use this BMP in areas with a high ground water table, or in areas that will have a high seasonal ground water table during the use of this BMP.
- This BMP may be less effective on soils that prevent the infiltration of the water, such as hard till.
- Using other effective source control measures throughout a construction site will prevent the generation of additional highly turbid water and may reduce the time period or area need for this BMP.
- Stop distributing water into the vegetated area if standing water or erosion results.

Design Criteria

- Find land adjacent to the project that has a vegetated field, preferably a farm field, or wooded area.
- If the project site does not contain enough vegetated field area consider obtaining

BMP C240: Sediment Trap

Purpose

A sediment trap is a small temporary ponding area with a gravel outlet used to collect and store sediment from sites cleared and/or graded during construction. Sediment traps, along with other perimeter controls, shall be installed before any land disturbance takes place in the drainage area.

Conditions of Use

Prior to leaving a construction site, stormwater runoff must pass through a sediment pond or trap or other appropriate sediment removal best management practice. Non-engineered sediment traps may be used on-site prior to an engineered sediment trap or sediment pond to provide additional sediment removal capacity.

It is intended for use on sites where the tributary drainage area is less than 3 acres, with no unusual drainage features, and a projected build-out time of six months or less. The sediment trap is a temporary measure (with a design life of approximately 6 months) and shall be maintained until the site area is permanently protected against erosion by vegetation and/or structures.

Sediment traps and ponds are only effective in removing sediment down to about the medium silt size fraction. Runoff with sediment of finer grades (fine silt and clay) will pass through untreated, emphasizing the need to control erosion to the maximum extent first.

Whenever possible, sediment-laden water shall be discharged into on-site, relatively level, vegetated areas (see [BMP C234: Vegetated Strip \(p.375\)](#)). This is the only way to effectively remove fine particles from runoff unless chemical treatment or filtration is used. This can be particularly useful after initial treatment in a sediment trap or pond. The areas of release must be evaluated on a site-by-site basis in order to determine appropriate locations for and methods of releasing runoff. Vegetated wetlands shall not be used for this purpose. Frequently, it may be possible to pump water from the collection point at the downhill end of the site to an upslope vegetated area. Pumping shall only augment the treatment system, not replace it, because of the possibility of pump failure or runoff volume in excess of pump capacity.

All projects that are constructing permanent facilities for runoff quantity control should use the rough-graded or final-graded permanent facilities for traps and ponds. This includes combined facilities and infiltration facilities. When permanent facilities are used as temporary sedimentation facilities, the surface area requirement of a sediment trap or pond must be met. If the surface area requirements are larger than the surface area of the permanent facility, then the trap or pond shall be enlarged to comply with the surface

area requirement. The permanent pond shall also be divided into two cells as required for sediment ponds.

Either a permanent control structure or the temporary control structure (described in [BMP C241: Temporary Sediment Pond \(p.388\)](#)) can be used. If a permanent control structure is used, it may be advisable to partially restrict the lower orifice with gravel to increase residence time while still allowing dewatering of the pond. A shut-off valve may be added to the control structure to allow complete retention of stormwater in emergency situations. In this case, an emergency overflow weir must be added.

A skimmer may be used for the sediment trap outlet if approved by the Local Permitting Authority.

Design and Installation Specifications

- See [Figure II-4.2.16 Cross Section of Sediment Trap \(p.386\)](#) and [Figure II-4.2.17 Sediment Trap Outlet \(p.387\)](#) for details.
- If permanent runoff control facilities are part of the project, they should be used for sediment retention.
- To determine the sediment trap geometry, first calculate the design surface area (SA) of the trap, measured at the invert of the weir. Use the following equation:

$$SA = FS(Q_2/V_s)$$

where

Q_2 = Design inflow based on the peak discharge from the developed 2-year runoff event from the contributing drainage area as computed in the hydrologic analysis. The 10-year peak flow shall be used if the project size, expected timing and duration of construction, or downstream conditions warrant a higher level of protection. If no hydrologic analysis is required, the Rational Method may be used.

V_s = The settling velocity of the soil particle of interest. The 0.02 mm (medium silt) particle with an assumed density of 2.65 g/cm³ has been selected as the particle of interest and has a settling velocity (V_s) of 0.00096 ft/sec.

FS = A safety factor of 2 to account for non-ideal settling.

Therefore, the equation for computing surface area becomes:

$$SA = 2 \times Q_2 / 0.00096$$

or

2080 square feet per cfs of inflow

Note: Even if permanent facilities are used, they must still have a surface area that is at least as large as that derived from the above formula. If they do not, the pond must be enlarged.

- To aid in determining sediment depth, all sediment traps shall have a staff gauge with a prominent mark 1-foot above the bottom of the trap.
- Sediment traps may not be feasible on utility projects due to the limited work space or the short-term nature of the work. Portable tanks may be used in place of sediment traps for utility projects.

Maintenance Standards

- Sediment shall be removed from the trap when it reaches 1-foot in depth.
- Any damage to the pond embankments or slopes shall be repaired.

Figure II-4.2.16 Cross Section of Sediment Trap

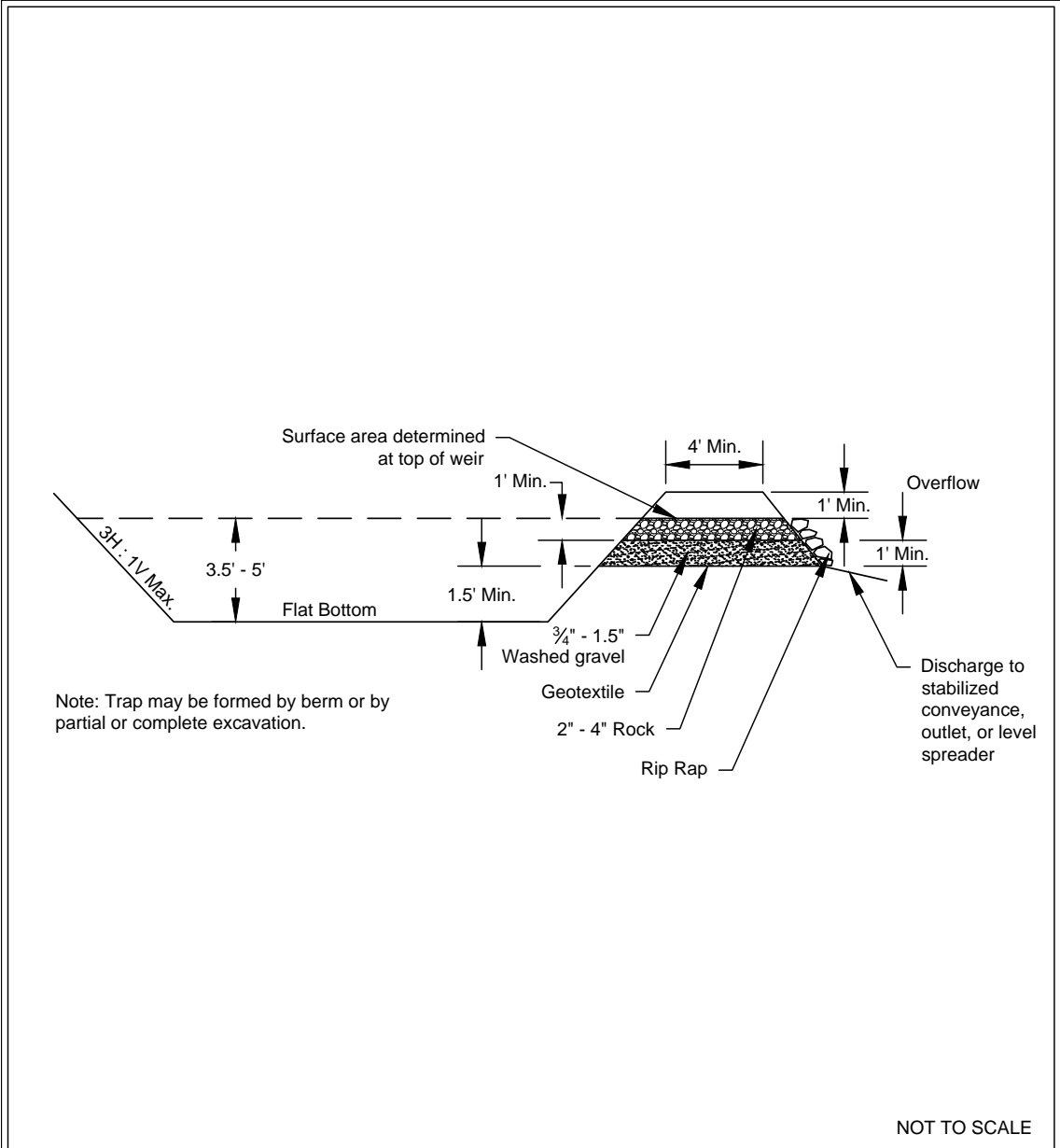
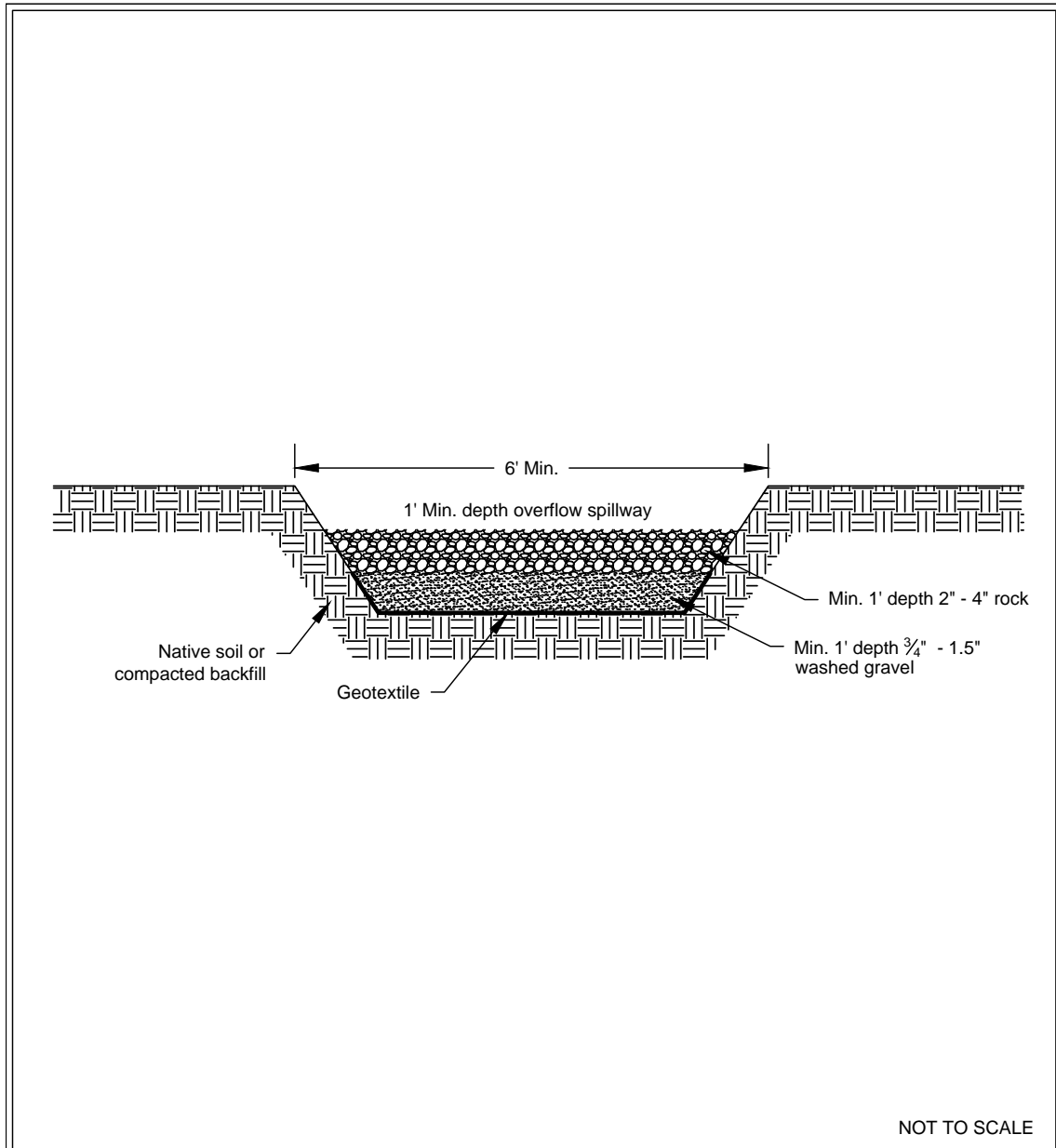

**Figure II-4.2.16
Cross Section of Sediment Trap**

Revised November 2015

Please see <http://www.ecy.wa.gov/copyright.html> for copyright notice including permissions, limitation of liability, and disclaimer.

Figure II-4.2.17 Sediment Trap Outlet



**Figure II-4.2.17
Sediment Trap Outlet**

Revised November 2015

Please see <http://www.ecy.wa.gov/copyright.html> for copyright notice including permissions, limitation of liability, and disclaimer.

C. Site Inspection Form

Construction Stormwater Site Inspection Form

Project Name _____ **Permit #** _____ **Inspection Date** _____ **Time** _____

Name of Certified Erosion Sediment Control Lead (CESCL) or qualified inspector if *less than one acre*

Print Name: _____

Approximate rainfall amount since the last inspection (in inches): _____

Approximate rainfall amount in the last 24 hours (in inches): _____

Current Weather Clear Cloudy Mist Rain Wind Fog

A. Type of inspection: Weekly Post Storm Event Other

B. Phase of Active Construction (check all that apply):

Pre Construction/installation of erosion/sediment controls	<input type="checkbox"/>	Clearing/Demo/Grading	<input type="checkbox"/>
Concrete pours	<input type="checkbox"/>	Vertical Construction/buildings	<input type="checkbox"/>
Offsite improvements	<input type="checkbox"/>	Site temporary stabilized	<input type="checkbox"/>
		Infrastructure/storm/roads	<input type="checkbox"/>
		Utilities	<input type="checkbox"/>
		Final stabilization	<input type="checkbox"/>

C. Questions:

- | | | | | |
|--|-----|----|-------|-------|
| 1. Were all areas of construction and discharge points inspected? | Yes | No | _____ | _____ |
| 2. Did you observe the presence of suspended sediment, turbidity, discoloration, or oil sheen | Yes | No | _____ | _____ |
| 3. Was a water quality sample taken during inspection? (<i>refer to permit conditions S4 & S5</i>) | Yes | No | _____ | _____ |
| 4. Was there a turbid discharge 250 NTU or greater, or Transparency 6 cm or less?* | Yes | No | _____ | _____ |
| 5. If yes to #4 was it reported to Ecology? | Yes | No | _____ | _____ |
| 6. Is pH sampling required? pH range required is 6.5 to 8.5. | Yes | No | _____ | _____ |

If answering yes to a discharge, describe the event. Include when, where, and why it happened; what action was taken, and when.

*If answering yes to # 4 record NTU/Transparency with continual sampling daily until turbidity is 25 NTU or less/ transparency is 33 cm or greater.

Sampling Results: _____ Date: _____

Parameter	Method (circle one)	Result			Other/Note
		NTU	cm	pH	
Turbidity	tube, meter, laboratory				
pH	Paper, kit, meter				

Construction Stormwater Site Inspection Form

D. Check the observed status of all items. Provide "Action Required" details and dates.

Element #	Inspection	BMPs Inspected			BMP needs maintenance	BMP failed	Action required (describe in section F)
		yes	no	n/a			
1 Clearing Limits	Before beginning land disturbing activities are all clearing limits, natural resource areas (streams, wetlands, buffers, trees) protected with barriers or similar BMPs? (high visibility recommended)						
2 Construction Access	Construction access is stabilized with quarry spalls or equivalent BMP to prevent sediment from being tracked onto roads?						
	Sediment tracked onto the road way was cleaned thoroughly at the end of the day or more frequent as necessary.						
3 Control Flow Rates	Are flow control measures installed to control stormwater volumes and velocity during construction and do they protect downstream properties and waterways from erosion?						
	If permanent infiltration ponds are used for flow control during construction, are they protected from siltation?						
4 Sediment Controls	All perimeter sediment controls (e.g. silt fence, wattles, compost socks, berms, etc.) installed, and maintained in accordance with the Stormwater Pollution Prevention Plan (SWPPP).						
	Sediment control BMPs (sediment ponds, traps, filters etc.) have been constructed and functional as the first step of grading.						
	Stormwater runoff from disturbed areas is directed to sediment removal BMP.						
5 Stabilize Soils	Have exposed un-worked soils been stabilized with effective BMP to prevent erosion and sediment deposition?						

Construction Stormwater Site Inspection Form

Element #	Inspection	BMPs Inspected			BMP needs maintenance	BMP failed	Action required (describe in section F)
		yes	no	n/a			
5 Stabilize Soils Cont.	Are stockpiles stabilized from erosion, protected with sediment trapping measures and located away from drain inlet, waterways, and drainage channels?						
	Have soils been stabilized at the end of the shift, before a holiday or weekend if needed based on the weather forecast?						
6 Protect Slopes	Has stormwater and ground water been diverted away from slopes and disturbed areas with interceptor dikes, pipes and or swales?						
	Is off-site storm water managed separately from stormwater generated on the site?						
	Is excavated material placed on uphill side of trenches consistent with safety and space considerations?						
	Have check dams been placed at regular intervals within constructed channels that are cut down a slope?						
7 Drain Inlets	Storm drain inlets made operable during construction are protected.						
	Are existing storm drains within the influence of the project protected?						
8 Stabilize Channel and Outlets	Have all on-site conveyance channels been designed, constructed and stabilized to prevent erosion from expected peak flows?						
	Is stabilization, including armoring material, adequate to prevent erosion of outlets, adjacent stream banks, slopes and downstream conveyance systems?						
9 Control Pollutants	Are waste materials and demolition debris handled and disposed of to prevent contamination of stormwater?						
	Has cover been provided for all chemicals, liquid products, petroleum products, and other material?						
	Has secondary containment been provided capable of containing 110% of the volume?						
	Were contaminated surfaces cleaned immediately after a spill incident?						
	Were BMPs used to prevent contamination of stormwater by a pH modifying sources?						

Construction Stormwater Site Inspection Form

Element #	Inspection	BMPs Inspected			BMP needs maintenance	BMP failed	Action required (describe in section F)
		yes	no	n/a			
9 Cont.	Wheel wash wastewater is handled and disposed of properly.						
10 Control Dewatering	Concrete washout in designated areas. No washout or excess concrete on the ground.						
	Dewatering has been done to an approved source and in compliance with the SWPPP.						
	Were there any clean non turbid dewatering discharges?						
11 Maintain BMP	Are all temporary and permanent erosion and sediment control BMPs maintained to perform as intended?						
12 Manage the Project	Has the project been phased to the maximum degree practicable?						
	Has regular inspection, monitoring and maintenance been performed as required by the permit?						
	Has the SWPPP been updated, implemented and records maintained?						
13 Protect LID	Is all Bioretention and Rain Garden Facilities protected from sedimentation with appropriate BMPs?						
	Is the Bioretention and Rain Garden protected against over compaction of construction equipment and foot traffic to retain its infiltration capabilities?						
	Permeable pavements are clean and free of sediment and sediment laden-water runoff. Muddy construction equipment has not been on the base material or pavement.						
	Have soiled permeable pavements been cleaned of sediments and pass infiltration test as required by stormwater manual methodology?						
	Heavy equipment has been kept off existing soils under LID facilities to retain infiltration rate.						

E. Check all areas that have been inspected. ✓

All in place BMPs All disturbed soils All concrete wash out area All material storage areas
 All discharge locations All equipment storage areas All construction entrances/exits

Construction Stormwater Site Inspection Form

F. Elements checked "Action Required" (section D) describe corrective action to be taken. List the element number; be specific on location and work needed. Document, initial, and date when the corrective action has been completed and inspected.

Element #	Description and Location	Action Required	Completion Date	Initials

Attach additional page if needed

Sign the following certification:

"I certify that this report is true, accurate, and complete, to the best of my knowledge and belief"

Inspected by: (print) _____ (Signature) _____ Date: _____

Title/Qualification of Inspector: _____

D. Construction Stormwater General Permit (CSWGP)

Issuance Date: November 18, 2020
Effective Date: January 1, 2021
Expiration Date: December 31, 2025

CONSTRUCTION STORMWATER GENERAL PERMIT

National Pollutant Discharge Elimination System (NPDES) and State Waste Discharge
General Permit for Stormwater Discharges Associated with Construction Activity

State of Washington
Department of Ecology
Olympia, Washington 98504

In compliance with the provisions of
Chapter 90.48 Revised Code of Washington
(State of Washington Water Pollution Control Act)
and
Title 33 United States Code, Section 1251 et seq.
The Federal Water Pollution Control Act (The Clean Water Act)

Until this permit expires, is modified, or revoked, Permittees that have properly
obtained coverage under this general permit are authorized to discharge in accordance
with the special and general conditions that follow.



Vincent McGowan, P.E.
Water Quality Program Manager
Washington State Department of Ecology

TABLE OF CONTENTS

LIST OF TABLES	ii
SUMMARY OF PERMIT REPORT SUBMITTALS.....	1
SPECIAL CONDITIONS	3
S1. Permit Coverage	3
S2. Application Requirements	7
S3. Compliance with Standards	9
S4. Monitoring Requirements, Benchmarks, and Reporting Triggers	10
S5. Reporting and Recordkeeping Requirements.....	17
S6. Permit Fees	20
S7. Solid and Liquid Waste Disposal	20
S8. Discharges to 303(D) or TMDL Waterbodies	20
S9. Stormwater Pollution Prevention Plan	23
S10. Notice Of Termination	32
GENERAL CONDITIONS	34
G1. Discharge Violations.....	34
G2. Signatory Requirements	34
G3. Right of Inspection and Entry.....	35
G4. General Permit Modification and Revocation	35
G5. Revocation of Coverage Under tPermit.....	35
G6. Reporting a Cause for Modification.....	36
G7. Compliance with Other Laws and Statutes.....	36
G8. Duty to Reapply.....	36
G9. Removed Substance.....	36
G10. Duty to Provide Information.....	36
G11. Other Requirements of 40 CFR	37
G12. Additional Monitoring.....	37
G13. Penalties for Violating Permit Conditions.....	37
G14. Upset.....	37
G15. Property Rights	37
G16. Duty to Comply	37
G17. Toxic Pollutants.....	38
G18. Penalties for Tampering.....	38
G19. Reporting Planned Changes.....	38
G20. Reporting Other Information.....	38
G21. Reporting Anticipated Non-Compliance	38

G22.	Requests to Be Excluded From Coverage Under the Permit	39
G23.	Appeals.....	39
G24.	Severability.....	39
G25.	Bypass Prohibited	39
APPENDIX A – DEFINITIONS.....		42
APPENDIX B – ACRONYMS.....		50

LIST OF TABLES

Table 1	Summary of Required Submittals.....	1
Table 2	Summary of Required On-site Documentation	2
Table 3	Summary of Primary Monitoring Requirements	12
Table 4	Monitoring and Reporting Requirements	14
Table 5	Turbidity, Fine Sediment & Phosphorus Sampling and Limits for 303(d)-Listed Waters	22
Table 6	pH Sampling and Limits for 303(d)-Listed Waters.....	22

SUMMARY OF PERMIT REPORT SUBMITTALS

Refer to the Special and General Conditions within this permit for additional submittal requirements. Appendix A provides a list of definitions. Appendix B provides a list of acronyms.

Table 1 Summary of Required Submittals

Permit Section	Submittal	Frequency	First Submittal Date
S5.A and S8	High Turbidity/Transparency Phone Reporting	As Necessary	Within 24 hours
S5.B	Discharge Monitoring Report	Monthly*	Within 15 days following the end of each month
S5.F and S8	Noncompliance Notification – Telephone Notification	As necessary	Within 24 hours
S5.F	Noncompliance Notification – Written Report	As necessary	Within 5 Days of non-compliance
S9.D	Request for Chemical Treatment Form	As necessary	Written approval from Ecology is required prior to using chemical treatment (with the exception of dry ice, CO ₂ or food grade vinegar to adjust pH)
G2	Notice of Change in Authorization	As necessary	
G6	Permit Application for Substantive Changes to the Discharge	As necessary	
G8	Application for Permit Renewal	1/permit cycle	No later than 180 days before expiration
S2.A	Notice of Permit Transfer	As necessary	
G19	Notice of Planned Changes	As necessary	
G21	Reporting Anticipated Non-compliance	As necessary	

NOTE: *Permittees must submit electronic Discharge Monitoring Reports (DMRs) to the Washington State Department of Ecology monthly, regardless of site discharge, for the full duration of permit coverage. Refer to Section S5.B of this General Permit for more specific information regarding DMRs.

Table 2 Summary of Required On-site Documentation

Document Title	Permit Conditions
Permit Coverage Letter	See Conditions S2, S5
Construction Stormwater General Permit (CSWGP)	See Conditions S2, S5
Site Log Book	See Conditions S4, S5
Stormwater Pollution Prevention Plan (SWPPP)	See Conditions S5, S9
Site Map	See Conditions S5, S9

SPECIAL CONDITIONS

S1. PERMIT COVERAGE

A. Permit Area

This Construction Stormwater General Permit (CSWGP) covers all areas of Washington State, except for federal operators and Indian Country as specified in Special Condition S1.E.3 and 4.

B. Operators Required to Seek Coverage Under this General Permit

1. Operators of the following construction activities are required to seek coverage under this CSWGP:
 - a. Clearing, grading and/or excavation that results in the disturbance of one or more acres (including off-site disturbance acreage related to construction-support activity as authorized in S1.C.2) and discharges stormwater to surface waters of the State; and clearing, grading and/or excavation on sites smaller than one acre that are part of a larger common plan of development or sale, if the common plan of development or sale will ultimately disturb one acre or more and discharge stormwater to surface waters of the State.
 - i. This category includes forest practices (including, but not limited to, class IV conversions) that are part of a construction activity that will result in the disturbance of one or more acres, and discharge to surface waters of the State (that is, forest practices that prepare a site for construction activities); and
 - b. Any size construction activity discharging stormwater to waters of the State that the Washington State Department of Ecology (Ecology):
 - i. Determines to be a significant contributor of pollutants to waters of the State of Washington.
 - ii. Reasonably expects to cause a violation of any water quality standard.
2. Operators of the following activities are not required to seek coverage under this CSWGP (unless specifically required under Special Condition S1.B.1.b, above):
 - a. Construction activities that discharge all stormwater and non-stormwater to groundwater, sanitary sewer, or combined sewer, and have no point source discharge to either surface water or a storm sewer system that drains to surface waters of the State.
 - b. Construction activities covered under an Erosivity Waiver (Special Condition S1.F).
 - c. Routine maintenance that is performed to maintain the original line and grade, hydraulic capacity, or original purpose of a facility.

C. Authorized Discharges

1. **Stormwater Associated with Construction Activity.** Subject to compliance with the terms and conditions of this permit, Permittees are authorized to discharge stormwater associated with construction activity to surface waters of the State or to a storm sewer system that drains to surface waters of the State. (Note that “surface waters of the

State” may exist on a construction site as well as off site; for example, a creek running through a site.)

2. **Stormwater Associated with Construction Support Activity.** This permit also authorizes stormwater discharge from support activities related to the permitted construction site (for example, an on-site portable rock crusher, off-site equipment staging yards, material storage areas, borrow areas, etc.) provided:
 - a. The support activity relates directly to the permitted construction site that is required to have an NPDES permit; and
 - b. The support activity is not a commercial operation serving multiple unrelated construction projects, and does not operate beyond the completion of the construction activity; and
 - c. Appropriate controls and measures are identified in the Stormwater Pollution Prevention Plan (SWPPP) for the discharges from the support activity areas.
3. **Non-Stormwater Discharges.** The categories and sources of non-stormwater discharges identified below are authorized conditionally, provided the discharge is consistent with the terms and conditions of this permit:
 - a. Discharges from fire-fighting activities.
 - b. Fire hydrant system flushing.
 - c. Potable water, including uncontaminated water line flushing.
 - d. Hydrostatic test water.
 - e. Uncontaminated air conditioning or compressor condensate.
 - f. Uncontaminated groundwater or spring water.
 - g. Uncontaminated excavation dewatering water (in accordance with S9.D.10).
 - h. Uncontaminated discharges from foundation or footing drains.
 - i. Uncontaminated or potable water used to control dust. Permittees must minimize the amount of dust control water used.
 - j. Routine external building wash down that does not use detergents.
 - k. Landscape irrigation water.

The SWPPP must adequately address all authorized non-stormwater discharges, except for discharges from fire-fighting activities, and must comply with Special Condition S3. At a minimum, discharges from potable water (including water line flushing), fire hydrant system flushing, and pipeline hydrostatic test water must undergo the following: dechlorination to a concentration of 0.1 parts per million (ppm) or less, and pH adjustment to within 6.5 – 8.5 standard units (su), if necessary.

D. Prohibited Discharges

The following discharges to waters of the State, including groundwater, are prohibited:

1. Concrete wastewater
2. Wastewater from washout and clean-up of stucco, paint, form release oils, curing compounds and other construction materials.
3. Process wastewater as defined by 40 Code of Federal Regulations (CFR) 122.2 (See Appendix A of this permit).
4. Slurry materials and waste from shaft drilling, including process wastewater from shaft drilling for construction of building, road, and bridge foundations unless managed according to Special Condition S9.D.9.j.
5. Fuels, oils, or other pollutants used in vehicle and equipment operation and maintenance.
6. Soaps or solvents used in vehicle and equipment washing.
7. Wheel wash wastewater, unless managed according to Special Condition S9.D.9.
8. Discharges from dewatering activities, including discharges from dewatering of trenches and excavations, unless managed according to Special Condition S9.D.10.

E. Limits on Coverage

Ecology may require any discharger to apply for and obtain coverage under an individual permit or another more specific general permit. Such alternative coverage will be required when Ecology determines that this CSWGP does not provide adequate assurance that water quality will be protected, or there is a reasonable potential for the project to cause or contribute to a violation of water quality standards.

The following stormwater discharges are not covered by this permit:

1. Post-construction stormwater discharges that originate from the site after completion of construction activities and the site has undergone final stabilization.
2. Non-point source silvicultural activities such as nursery operations, site preparation, reforestation and subsequent cultural treatment, thinning, prescribed burning, pest and fire control, harvesting operations, surface drainage, or road construction and maintenance, from which there is natural runoff as excluded in 40 CFR Subpart 122.
3. Stormwater from any federal operator.
4. Stormwater from facilities located on **Indian Country** as defined in 18 U.S.C. §1151, except portions of the Puyallup Reservation as noted below.

Indian Country includes:

- a. All land within any Indian Reservation notwithstanding the issuance of any patent, and, including rights-of-way running through the reservation. This includes all federal, tribal, and Indian and non-Indian privately owned land within the reservation.
- b. All off-reservation Indian allotments, the Indian titles to which have not been extinguished, including rights-of-way running through the same.
- c. All off-reservation federal trust lands held for Native American Tribes.

Puyallup Exception: Following the *Puyallup Tribes of Indians Land Settlement Act of 1989*, 25 U.S.C. §1773; the permit does apply to land within the Puyallup Reservation except for discharges to surface water on land held in trust by the federal government.

5. Stormwater from any site covered under an existing NPDES individual permit in which stormwater management and/or treatment requirements are included for all stormwater discharges associated with construction activity.
6. Stormwater from a site where an applicable Total Maximum Daily Load (TMDL) requirement specifically precludes or prohibits discharges from construction activity.

F. Erosivity Waiver

Construction site operators may qualify for an Erosivity Waiver from the CSWGP if the following conditions are met:

1. The site will result in the disturbance of fewer than five (5) acres and the site is not a portion of a common plan of development or sale that will disturb five (5) acres or greater.
2. Calculation of Erosivity “R” Factor and Regional Timeframe:
 - a. The project’s calculated rainfall erosivity factor (“R” Factor) must be less than five (5) during the period of construction activity, (See the CSWGP homepage <http://www.ecy.wa.gov/programs/wq/stormwater/construction/index.html> for a link to the EPA’s calculator and step by step instructions on computing the “R” Factor in the *EPA Erosivity Waiver Fact Sheet*). The period of construction activity starts when the land is first disturbed and ends with final stabilization. In addition:
 - b. The entire period of construction activity must fall within the following timeframes:
 - i. For sites west of the Cascades Crest: June 15 – September 15.
 - ii. For sites east of the Cascades Crest, excluding the Central Basin: June 15 – October 15.
 - iii. For sites east of the Cascades Crest, within the Central Basin: no timeframe restrictions apply. The Central Basin is defined as the portions of Eastern Washington with mean annual precipitation of less than 12 inches. For a map of the Central Basin (Average Annual Precipitation Region 2), refer to: <http://www.ecy.wa.gov/programs/wq/stormwater/construction/resourcesguidance.html>.
3. Construction site operators must submit a complete Erosivity Waiver certification form at least one week before disturbing the land. Certification must include statements that the operator will:
 - a. Comply with applicable local stormwater requirements; and
 - b. Implement appropriate erosion and sediment control BMPs to prevent violations of water quality standards.
4. This waiver is not available for facilities declared significant contributors of pollutants as defined in Special Condition S1.B.1.b or for any size construction activity that could

reasonably expect to cause a violation of any water quality standard as defined in Special Condition S1.B.1.b.ii.

5. This waiver does not apply to construction activities which include non-stormwater discharges listed in Special Condition S1.C.3.
6. If construction activity extends beyond the certified waiver period for any reason, the operator must either:
 - a. Recalculate the rainfall erosivity “R” factor using the original start date and a new projected ending date and, if the “R” factor is still under 5 *and* the entire project falls within the applicable regional timeframe in Special Condition S1.F.2.b, complete and submit an amended waiver certification form before the original waiver expires; *or*
 - b. Submit a complete permit application to Ecology in accordance with Special Condition S2.A and B before the end of the certified waiver period.

S2. APPLICATION REQUIREMENTS

A. Permit Application Forms

1. *Notice of Intent Form*

- a. Operators of new or previously unpermitted construction activities must submit a complete and accurate permit application (Notice of Intent, or NOI) to Ecology.
- b. Operators must apply using the electronic application form (NOI) available on Ecology’s website (<http://ecy.wa.gov/programs/wq/stormwater/construction/index.html>). Permittees unable to submit electronically (for example, those who do not have an internet connection) must contact Ecology to request a waiver and obtain instructions on how to obtain a paper NOI.

Department of Ecology
Water Quality Program - Construction Stormwater
PO Box 47696
Olympia, Washington 98504-7696

- c. The operator must submit the NOI at least 60 days before discharging stormwater from construction activities and must submit it prior to the date of the first public notice (See Special Condition S2.B, below, for details). The 30-day public comment period begins on the publication date of the second public notice. Unless Ecology responds to the complete application in writing, coverage under the general permit will automatically commence on the 31st day following receipt by Ecology of a *completed* NOI, or the issuance date of this permit, whichever is later; unless Ecology specifies a later date in writing as required by WAC173-226-200(2). See S8.B for Limits on Coverage for New Discharges to TMDL or 303(d)-Listed Waters.
- d. If an applicant intends to use a Best Management Practice (BMP) selected on the basis of Special Condition S9.C.4 (“demonstrably equivalent” BMPs), the applicant must notify Ecology of its selection as part of the NOI. In the event the applicant selects BMPs after submission of the NOI, the applicant must provide notice of the

selection of an equivalent BMP to Ecology at least 60 days before intended use of the equivalent BMP.

- e. Applicants must notify Ecology if they are aware of contaminated soils and/or groundwater associated with the construction activity. Provide detailed information with the NOI (as known and readily available) on the nature and extent of the contamination (concentrations, locations, and depth), as well as pollution prevention and/or treatment BMPs proposed to control the discharge of soil and/or groundwater contaminants in stormwater. Examples of such detail may include, but are not limited to:
 - i. List or table of all known contaminants with laboratory test results showing concentration and depth,
 - ii. Map with sample locations,
 - iii. Related portions of the Stormwater Pollution Prevention Plan (SWPPP) that address the management of contaminated and potentially contaminated construction stormwater and dewatering water,
 - iv. Dewatering plan and/or dewatering contingency plan.

2. ***Transfer of Coverage Form***

The Permittee can transfer current coverage under this permit to one or more new operators, including operators of sites within a Common Plan of Development, provided:

- i. The Permittee submits a complete Transfer of Coverage Form to Ecology, signed by the current and new discharger and containing a specific date for transfer of permit responsibility, coverage and liability (including any Administrative Orders associated with the permit); and
- ii. Ecology does not notify the current discharger and new discharger of intent to revoke coverage under the general permit. If this notice is not given, the transfer is effective on the date specified in the written agreement.

When a current discharger (Permittee) transfers a portion of a permitted site, the current discharger must also indicate the remaining permitted acreage after the transfer. Transfers do not require public notice.

3. ***Modification of Coverage Form***

Permittees must notify Ecology regarding any changes to the information provided on the NOI by submitting an Update/Modification of Permit Coverage form in accordance with General Conditions G6 and G19. Examples of such changes include, but are not limited to:

- i. Changes to the Permittee's mailing address,
- ii. Changes to the on-site contact person information, and
- iii. Changes to the area/acreage affected by construction activity.

B. Public Notice

For new or previously unpermitted construction activities, the applicant must publish a public notice at least one time each week for two consecutive weeks, at least 7 days apart, in a newspaper with general circulation in the county where the construction is to take place. The notice must be run after the NOI has been submitted and must contain:

1. A statement that *“The applicant is seeking coverage under the Washington State Department of Ecology’s Construction Stormwater NPDES and State Waste Discharge General Permit.”*
2. The name, address, and location of the construction site.
3. The name and address of the applicant.
4. The type of construction activity that will result in a discharge (for example, residential construction, commercial construction, etc.), and the total number of acres to be disturbed over the lifetime of the project.
5. The name of the receiving water(s) (that is, the surface water(s) to which the site will discharge), or, if the discharge is through a storm sewer system, the name of the operator of the system and the receiving water(s) the system discharges to.
6. The statement: *Any persons desiring to present their views to the Washington State Department of Ecology regarding this application, or interested in Ecology’s action on this application, may notify Ecology in writing no later than 30 days of the last date of publication of this notice. Ecology reviews public comments and considers whether discharges from this project would cause a measurable change in receiving water quality, and, if so, whether the project is necessary and in the overriding public interest according to Tier II antidegradation requirements under WAC 173-201A-320. Comments can be submitted to: Department of Ecology, PO Box 47696, Olympia, Washington 98504-7696 Attn: Water Quality Program, Construction Stormwater.*

S3. COMPLIANCE WITH STANDARDS

- A. **Discharges must not** cause or contribute to a violation of surface water quality standards (Chapter 173-201A WAC), groundwater quality standards (Chapter 173-200 WAC), sediment management standards (Chapter 173-204 WAC), and human health-based criteria in the Federal water quality criteria applicable to Washington. (40 CFR Part 131.45) Discharges that are not in compliance with these standards are prohibited.
- B. **Prior to the discharge** of stormwater and non-stormwater to waters of the State, the Permittee must apply All Known, Available, and Reasonable methods of prevention, control, and Treatment (AKART). This includes the preparation and implementation of an adequate SWPPP, with all appropriate BMPs installed and maintained in accordance with the SWPPP and the terms and conditions of this permit.
- C. **Ecology presumes** that a Permittee complies with water quality standards unless discharge monitoring data or other site-specific information demonstrates that a discharge causes or contributes to a violation of water quality standards, when the Permittee complies with the following conditions. The Permittee must fully:

1. Comply with all permit conditions, including; planning, sampling, monitoring, reporting, and recordkeeping conditions.
 2. Implement stormwater BMPs contained in stormwater management manuals published or approved by Ecology, or BMPs that are demonstrably equivalent to BMPs contained in stormwater management manuals published or approved by Ecology, including the proper selection, implementation, and maintenance of all applicable and appropriate BMPs for on-site pollution control. (For purposes of this section, the stormwater manuals listed in Appendix 10 of the *Phase I Municipal Stormwater Permit* are approved by Ecology.)
- D. Where construction sites** also discharge to groundwater, the groundwater discharges must also meet the terms and conditions of this CSWGP. Permittees who discharge to groundwater through an injection well must also comply with any applicable requirements of the Underground Injection Control (UIC) regulations, Chapter 173-218 WAC.

S4. MONITORING REQUIREMENTS, BENCHMARKS, AND REPORTING TRIGGERS

A. Site Log Book

The Permittee must maintain a site log book that contains a record of the implementation of the SWPPP and other permit requirements, including the installation and maintenance of BMPs, site inspections, and stormwater monitoring.

B. Site Inspections

Construction sites one (1) acre or larger that discharge stormwater to surface waters of the State must have site inspections conducted by a Certified Erosion and Sediment Control Lead (CESCL). Sites less than one (1) acre may have a person without CESCL certification conduct inspections. (See Special Conditions S4.B.3 and B.4, below, for detailed requirements of the Permittee's CESCL.)

Site inspections must include all areas disturbed by construction activities, all BMPs, and all stormwater discharge points under the Permittee's operational control.

1. The Permittee must have staff knowledgeable in the principles and practices of erosion and sediment control. The CESCL (sites one acre or more) or inspector (sites less than one acre) must have the skills to assess the:
 - a. Site conditions and construction activities that could impact the quality of stormwater; and
 - b. Effectiveness of erosion and sediment control measures used to control the quality of stormwater discharges. The SWPPP must identify the CESCL or inspector, who must be present on site or on-call at all times. The CESCL (sites one (1) acre or more) must obtain this certification through an approved erosion and sediment control training program that meets the minimum training standards established by Ecology. (See BMP C160 in the manual, referred to in Special Condition S9.C.1 and 2.)
2. The CESCL or inspector must examine stormwater visually for the presence of suspended sediment, turbidity, discoloration, and oil sheen. BMP effectiveness must be evaluated to

determine if it is necessary to install, maintain, or repair BMPs to improve the quality of stormwater discharges.

Based on the results of the inspection, the Permittee must correct the problems identified, by:

- a. Reviewing the SWPPP for compliance with Special Condition S9 and making appropriate revisions within 7 days of the inspection.
 - b. Immediately beginning the process of fully implementing and maintaining appropriate source control and/or treatment BMPs, within 10 days of the inspection. If installation of necessary treatment BMPs is not feasible within 10 days, Ecology may approve additional time when an extension is requested by a Permittee within the initial 10-day response period.
 - c. Documenting BMP implementation and maintenance in the site log book.
3. The CESCL or inspector must inspect all areas disturbed by construction activities, all BMPs, and all stormwater discharge points at least once every calendar week and within 24 hours of any discharge from the site. (For purposes of this condition, individual discharge events that last more than one (1) day do not require daily inspections. For example, if a stormwater pond discharges continuously over the course of a week, only one (1) inspection is required that week.) Inspection frequency may be reduced to once every calendar month for inactive sites that are temporarily stabilized.
4. The Permittee must summarize the results of each inspection in an inspection report or checklist and enter the report/checklist into, or attach it to, the site log book. At a minimum, each inspection report or checklist must include:
- a. Inspection date and time.
 - b. Weather information.
 - c. The general conditions during inspection.
 - d. The approximate amount of precipitation since the last inspection.
 - e. The approximate amount of precipitation within the last 24 hours.
 - f. A summary or list of all implemented BMPs, including observations of all erosion/sediment control structures or practices.
 - g. A description of:
 - i. BMPs inspected (including location).
 - ii. BMPs that need maintenance and why.
 - iii. BMPs that failed to operate as designed or intended, and
 - iv. Where additional or different BMPs are needed, and why.
 - h. A description of stormwater discharged from the site. The Permittee must note the presence of suspended sediment, turbidity, discoloration, and oil sheen, as applicable.

- i. Any water quality monitoring performed during inspection.
- j. General comments and notes, including a brief description of any BMP repairs, maintenance, or installations made following the inspection.
- k. An implementation schedule for the remedial actions that the Permittee plans to take if the site inspection indicates that the site is out of compliance. The remedial actions taken must meet the requirements of the SWPPP and the permit.
- l. A summary report of the inspection.
- m. The name, title, and signature of the person conducting the site inspection, a phone number or other reliable method to reach this person, and the following statement:
I certify that this report is true, accurate, and complete to the best of my knowledge and belief.

Table 3 Summary of Primary Monitoring Requirements

Size of Soil Disturbance ¹	Weekly Site Inspections	Weekly Sampling w/ Turbidity Meter	Weekly Sampling w/ Transparency Tube	Weekly pH Sampling ²	CESCL Required for Inspections?
Sites that disturb less than 1 acre, but are part of a larger Common Plan of Development	Required	Not Required	Not Required	Not Required	No
Sites that disturb 1 acre or more, but fewer than 5 acres	Required	Sampling Required – either method ³		Required	Yes
Sites that disturb 5 acres or more	Required	Required	Not Required ⁴	Required	Yes

¹ Soil disturbance is calculated by adding together all areas that will be affected by construction activity. Construction activity means clearing, grading, excavation, and any other activity that disturbs the surface of the land, including ingress/egress from the site.

² If construction activity results in the disturbance of 1 acre or more, and involves significant concrete work (1,000 cubic yards of concrete or recycled concrete placed or poured over the life of a project) or the use of engineered soils (soil amendments including but not limited to Portland cement-treated base [CTB], cement kiln dust [CKD], or fly ash), and stormwater from the affected area drains to surface waters of the State or to a storm sewer stormwater collection system that drains to other surface waters of the State, the Permittee must conduct pH sampling in accordance with Special Condition S4.D.

³ Sites with one or more acres, but fewer than 5 acres of soil disturbance, must conduct turbidity or transparency sampling in accordance with Special Condition S4.C.4.a or b.

⁴ Sites equal to or greater than 5 acres of soil disturbance must conduct turbidity sampling using a turbidity meter in accordance with Special Condition S4.C.4.a.

C. Turbidity/Transparency Sampling Requirements

1. Sampling Methods

- a. If construction activity involves the disturbance of five (5) acres or more, the Permittee must conduct turbidity sampling per Special Condition S4.C.4.a, below.
- b. If construction activity involves one (1) acre or more but fewer than five (5) acres of soil disturbance, the Permittee must conduct either transparency sampling *or* turbidity sampling per Special Condition S4.C.4.a or b, below.

2. Sampling Frequency

- a. The Permittee must sample all discharge points at least once every calendar week when stormwater (or authorized non-stormwater) discharges from the site or enters any on-site surface waters of the state (for example, a creek running through a site); sampling is not required on sites that disturb less than an acre.
- b. Samples must be representative of the flow and characteristics of the discharge.
- c. Sampling is not required when there is no discharge during a calendar week.
- d. Sampling is not required outside of normal working hours or during unsafe conditions.
- e. If the Permittee is unable to sample during a monitoring period, the Permittee must include a brief explanation in the monthly Discharge Monitoring Report (DMR).
- f. Sampling is not required before construction activity begins.
- g. The Permittee may reduce the sampling frequency for temporarily stabilized, inactive sites to once every calendar month.

3. Sampling Locations

- a. Sampling is required at all points where stormwater associated with construction activity (or authorized non-stormwater) is discharged off site, including where it enters any on-site surface waters of the state (for example, a creek running through a site).
- b. The Permittee may discontinue sampling at discharge points that drain areas of the project that are fully stabilized to prevent erosion.
- c. The Permittee must identify all sampling point(s) in the SWPPP and on the site map and clearly mark these points in the field with a flag, tape, stake or other visible marker.
- d. Sampling is not required for discharge that is sent directly to sanitary or combined sewer systems.
- e. The Permittee may discontinue sampling at discharge points in areas of the project where the Permittee no longer has operational control of the construction activity.

4. Sampling and Analysis Methods

- a. The Permittee performs turbidity analysis with a calibrated turbidity meter (turbidimeter) either on site or at an accredited lab. The Permittee must record the results in the site log book in nephelometric turbidity units (NTUs).
- b. The Permittee performs transparency analysis on site with a 1¾ inch diameter, 60 centimeter (cm)-long transparency tube. The Permittee will record the results in the site log book in centimeters (cm).

Table 4 Monitoring and Reporting Requirements

Parameter	Unit	Analytical Method	Sampling Frequency	Benchmark Value
Turbidity	NTU	SM2130	Weekly, if discharging	25 NTUs
Transparency	Cm	Manufacturer instructions, or Ecology guidance	Weekly, if discharging	33 cm

5. Turbidity/Transparency Benchmark Values and Reporting Triggers

The benchmark value for turbidity is 25 NTUs. The benchmark value for transparency is 33 centimeters (cm). Note: Benchmark values do not apply to discharges to segments of water bodies on Washington State’s 303(d) list (Category 5) for turbidity, fine sediment, or phosphorus; these discharges are subject to a numeric effluent limit for turbidity. Refer to Special Condition S8 for more information and follow S5.F – Noncompliance Notification for reporting requirements applicable to discharges which exceed the numeric effluent limit for turbidity.

- a. Turbidity 26 – 249 NTUs, or Transparency 32 – 7 cm:

If the discharge turbidity is 26 to 249 NTUs; or if discharge transparency is 32 to 7 cm, the Permittee must:

- i. Immediately begin the process to fully implement and maintain appropriate source control and/or treatment BMPs, and no later than 10 days of the date the discharge exceeded the benchmark. If installation of necessary treatment BMPs is not feasible within 10 days, Ecology may approve additional time when the Permittee requests an extension within the initial 10-day response period.
- ii. Review the SWPPP for compliance with Special Condition S9 and make appropriate revisions within 7 days of the date the discharge exceeded the benchmark.
- iii. Document BMP implementation and maintenance in the site log book.

- b. Turbidity 250 NTUs or greater, or Transparency 6 cm or less:

If a discharge point’s turbidity is 250 NTUs or greater, or if discharge transparency is less than or equal to 6 cm, the Permittee must complete the reporting and adaptive

management process described below. For discharges which are subject to a numeric effluent limit for turbidity, see S5.F – Noncompliance Notification.

- i. Within 24 hours, telephone or submit an electronic report to the applicable Ecology Region’s Environmental Report Tracking System (ERTS) number (or through Ecology’s Water Quality Permitting Portal [WQWebPortal] – Permit Submittals when the form is available), in accordance with Special Condition S5.A.
 - **Central Region** (Okanogan, Chelan, Douglas, Kittitas, Yakima, Klickitat, Benton): (509) 575-2490
 - **Eastern Region** (Adams, Asotin, Columbia, Ferry, Franklin, Garfield, Grant, Lincoln, Pend Oreille, Spokane, Stevens, Walla Walla, Whitman): (509) 329-3400
 - **Northwest Region** (Kitsap, Snohomish, Island, King, San Juan, Skagit, Whatcom): (425) 649-7000
 - **Southwest Region** (Grays Harbor, Lewis, Mason, Thurston, Pierce, Clark, Cowlitz, Skamania, Wahkiakum, Clallam, Jefferson, Pacific): (360) 407-6300

These numbers and a link to the ERTS reporting page are also listed at the following website: <http://www.ecy.wa.gov/programs/wq/stormwater/construction/index.html>.

- ii. Immediately begin the process to fully implement and maintain appropriate source control and/or treatment BMPs as soon as possible, addressing the problems within 10 days of the date the discharge exceeded the benchmark. If installation of necessary treatment BMPs is not feasible within 10 days, Ecology may approve additional time when the Permittee requests an extension within the initial 10-day response period.
- iii. Sample discharges daily until:
 - a) Turbidity is 25 NTUs (or lower); or
 - b) Transparency is 33 cm (or greater); or
 - c) The Permittee has demonstrated compliance with the water quality standard for turbidity:
 - 1) No more than 5 NTUs over background turbidity, if background is less than 50 NTUs, or
 - 2) No more than 10% over background turbidity, if background is 50 NTUs or greater; or

*Note: background turbidity in the receiving water must be measured immediately upstream (upgradient) or outside of the area of influence of the discharge.
 - d) The discharge stops or is eliminated.
- iv. Review the SWPPP for compliance with Special Condition S9 and make appropriate revisions within seven (7) days of the date the discharge exceeded the benchmark.

- v. Document BMP implementation and maintenance in the site log book.

Compliance with these requirements does not relieve the Permittee from responsibility to maintain continuous compliance with permit benchmarks.

D. pH Sampling Requirements – Significant Concrete Work or Engineered Soils

If construction activity results in the disturbance of 1 acre or more, *and* involves significant concrete work (significant concrete work means greater than 1000 cubic yards placed or poured concrete or recycled concrete used over the life of a project) or the use of engineered soils (soil amendments including but not limited to Portland cement-treated base [CTB], cement kiln dust [CKD], or fly ash), and stormwater from the affected area drains to surface waters of the State or to a storm sewer system that drains to surface waters of the State, the Permittee must conduct pH sampling as set forth below. Note: In addition, discharges to segments of water bodies on Washington State's 303(d) list (Category 5) for high pH are subject to a numeric effluent limit for pH; refer to Special Condition S8.

1. The Permittee must perform pH analysis on site with a calibrated pH meter, pH test kit, or wide range pH indicator paper. The Permittee must record pH sampling results in the site log book.
2. During the applicable pH monitoring period defined below, the Permittee must obtain a representative sample of stormwater and conduct pH analysis at least once per week.
 - a. For sites with significant concrete work, the Permittee must begin the pH sampling period when the concrete is first placed or poured and exposed to precipitation, and continue weekly throughout and after the concrete placement, pour and curing period, until stormwater pH is in the range of 6.5 to 8.5 (su).
 - b. For sites with recycled concrete where monitoring is required, the Permittee must begin the weekly pH sampling period when the recycled concrete is first exposed to precipitation and must continue until the recycled concrete is fully stabilized with the stormwater pH in the range of 6.5 to 8.5 (su).
 - c. For sites with engineered soils, the Permittee must begin the pH sampling period when the soil amendments are first exposed to precipitation and must continue until the area of engineered soils is fully stabilized.
3. The Permittee must sample pH in the sediment trap/pond(s) or other locations that receive stormwater runoff from the area of significant concrete work or engineered soils before the stormwater discharges to surface waters.
4. The benchmark value for pH is 8.5 standard units. Anytime sampling indicates that pH is 8.5 or greater, the Permittee must either:
 - a. Prevent the high pH water (8.5 or above) from entering storm sewer systems or surface waters of the state; *or*
 - b. If necessary, adjust or neutralize the high pH water until it is in the range of pH 6.5 to 8.5 (su) using an appropriate treatment BMP such as carbon dioxide (CO₂) sparging, dry ice or food grade vinegar. The Permittee must obtain written approval from Ecology before using any form of chemical treatment other than CO₂ sparging, dry ice or food grade vinegar.

S5. REPORTING AND RECORDKEEPING REQUIREMENTS

A. High Turbidity Reporting

Anytime sampling performed in accordance with Special Condition S4.C indicates turbidity has reached the 250 NTUs or more (or transparency less than or equal to 6 cm), high turbidity reporting level, the Permittee must notify Ecology within 24 hours of analysis either by calling the applicable Ecology Region's Environmental Report Tracking System (ERTS) number by phone or by submitting an electronic ERTS report (through Ecology's Water Quality Permitting Portal (WQWebPortal) – Permit Submittals when the form is available). See the CSWGP website for links to ERTS and the WQWebPortal. (<http://www.ecy.wa.gov/programs/wq/stormwater/construction/index.html>) Also, see phone numbers in Special Condition S4.C.5.b.i.

B. Discharge Monitoring Reports (DMRs)

Permittees required to conduct water quality sampling in accordance with Special Conditions S4.C (Turbidity/Transparency), S4.D (pH), S8 (303[d]/TMDL sampling), and/or G12 (Additional Sampling) must submit the results to Ecology.

Permittees must submit monitoring data using Ecology's WQWebDMR web application accessed through Ecology's Water Quality Permitting Portal.

Permittees unable to submit electronically (for example, those who do not have an internet connection) must contact Ecology to request a waiver and obtain instructions on how to obtain a paper copy DMR at:

Department of Ecology
Water Quality Program - Construction Stormwater
PO Box 47696
Olympia, WA 98504-7696

Permittees who obtain a waiver not to use WQWebDMR must use the forms provided to them by Ecology; submittals must be mailed to the address above. Permittees must submit DMR forms to be received by Ecology within 15 days following the end of each month.

If there was no discharge during a given monitoring period, all Permittees must submit a DMR as required with "no discharge" entered in place of the monitoring results. DMRs are required for the full duration of permit coverage (from the first full month following the effective date of permit coverage up until Ecology has approved termination of the coverage). For more information, contact Ecology staff using information provided at the following website: www.ecy.wa.gov/programs/wq/permits/paris/contacts.html.

C. Records Retention

The Permittee must retain records of all monitoring information (site log book, sampling results, inspection reports/checklists, etc.), Stormwater Pollution Prevention Plan, copy of the permit coverage letter (including Transfer of Coverage documentation) and any other documentation of compliance with permit requirements for the entire life of the construction project and for a minimum of five (5) years following the termination of permit coverage. Such information must include all calibration and maintenance records, and records of all data used to complete the application for this permit. This period of retention must be extended during

the course of any unresolved litigation regarding the discharge of pollutants by the Permittee or when requested by Ecology.

D. Recording Results

For each measurement or sample taken, the Permittee must record the following information:

1. Date, place, method, and time of sampling or measurement.
2. The first and last name of the individual who performed the sampling or measurement.
3. The date(s) the analyses were performed.
4. The first and last name of the individual who performed the analyses.
5. The analytical techniques or methods used.
6. The results of all analyses.

E. Additional Monitoring by the Permittee

If the Permittee samples or monitors any pollutant more frequently than required by this permit using test procedures specified by Special Condition S4 of this permit, the sampling results for this monitoring must be included in the calculation and reporting of the data submitted in the Permittee's DMR.

F. Noncompliance Notification

In the event the Permittee is unable to comply with any part of the terms and conditions of this permit, and the resulting noncompliance may cause a threat to human health or the environment (such as but not limited to spills or fuels or other materials, catastrophic pond or slope failure, and discharges that violate water quality standards), or exceed numeric effluent limitations (see S8 – Discharges to 303(d) or TMDL Waterbodies), the Permittee must, upon becoming aware of the circumstance:

1. Notify Ecology within 24 hours of the failure to comply by calling the applicable Regional office ERTS phone number (refer to Special Condition S4.C.5.b.i, or go to <https://ecology.wa.gov/About-us/Get-involved/Report-an-environmental-issue> to find contact information for the regional offices.)
2. Immediately take action to prevent the discharge/pollution, or otherwise stop or correct the noncompliance, and, if applicable, repeat sampling and analysis of any noncompliance immediately and submit the results to Ecology within five (5) days of becoming aware of the violation (See S5.F.3, below, for details on submitting results in a report).
3. Submit a detailed written report to Ecology within five (5) days of the time the Permittee becomes aware of the circumstances, unless requested earlier by Ecology. The report must be submitted using Ecology's Water Quality Permitting Portal (WQWebPortal) – Permit Submittals, unless a waiver from electronic reporting has been granted according to S5.B. The report must contain a description of the noncompliance, including exact dates and times, and if the noncompliance has not been corrected, the anticipated time it is expected to continue; and the steps taken or planned to reduce, eliminate, and prevent reoccurrence of the noncompliance.

The Permittee must report any unanticipated bypass and/or upset that exceeds any effluent limit in the permit in accordance with the 24-hour reporting requirement contained in 40 C.F.R. 122.41(l)(6).

Compliance with these requirements does not relieve the Permittee from responsibility to maintain continuous compliance with the terms and conditions of this permit or the resulting liability for failure to comply. Upon request of the Permittee, Ecology may waive the requirement for a written report on a case-by-case basis, if the immediate notification is received by Ecology within 24 hours.

G. Access to Plans and Records

1. The Permittee must retain the following permit documentation (plans and records) on site, or within reasonable access to the site, for use by the operator or for on-site review by Ecology or the local jurisdiction:
 - a. General Permit
 - b. Permit Coverage Letter
 - c. Stormwater Pollution Prevention Plan (SWPPP)
 - d. Site Log Book
 - e. Erosivity Waiver (if applicable)
2. The Permittee must address written requests for plans and records listed above (Special Condition S5.G.1) as follows:
 - a. The Permittee must provide a copy of plans and records to Ecology within 14 days of receipt of a written request from Ecology.
 - b. The Permittee must provide a copy of plans and records to the public when requested in writing. Upon receiving a written request from the public for the Permittee's plans and records, the Permittee must either:
 - i. Provide a copy of the plans and records to the requester within 14 days of a receipt of the written request; *or*
 - ii. Notify the requester within 10 days of receipt of the written request of the location and times within normal business hours when the plans and records may be viewed; and provide access to the plans and records within 14 days of receipt of the written request; *or*

Within 14 days of receipt of the written request, the Permittee may submit a copy of the plans and records to Ecology for viewing and/or copying by the requester at an Ecology office, or a mutually agreed location. If plans and records are viewed and/or copied at a location other than at an Ecology office, the Permittee will provide reasonable access to copying services for which a reasonable fee may be charged. The Permittee must notify the requester within 10 days of receipt of the request where the plans and records may be viewed and/or copied.

S6. PERMIT FEES

The Permittee must pay permit fees assessed by Ecology. Fees for stormwater discharges covered under this permit are established by Chapter 173-224 WAC. Ecology continues to assess permit fees until the permit is terminated in accordance with Special Condition S10 or revoked in accordance with General Condition G5.

S7. SOLID AND LIQUID WASTE DISPOSAL

The Permittee must handle and dispose of solid and liquid wastes generated by construction activity, such as demolition debris, construction materials, contaminated materials, and waste materials from maintenance activities, including liquids and solids from cleaning catch basins and other stormwater facilities, in accordance with:

- A. Special Condition S3, Compliance with Standards.
- B. WAC 173-216-110.
- C. Other applicable regulations.

S8. DISCHARGES TO 303(d) OR TMDL WATERBODIES

A. Sampling and Numeric Effluent Limits For Certain Discharges to 303(d)-Listed Water Bodies

1. Permittees who discharge to segments of water bodies listed as impaired by the State of Washington under Section 303(d) of the Clean Water Act for turbidity, fine sediment, high pH, or phosphorus, must conduct water quality sampling according to the requirements of this section, and Special Conditions S4.C.2.b-f and S4.C.3.b-d, and must comply with the applicable numeric effluent limitations in S8.C and S8.D.
2. All references and requirements associated with Section 303(d) of the Clean Water Act mean the most current listing by Ecology of impaired waters (Category 5) that exists on January 1, 2021, or the date when the operator's complete permit application is received by Ecology, whichever is later.

B. Limits on Coverage for New Discharges to TMDL or 303(d)-Listed Waters

Construction sites that discharge to a TMDL or 303(d)-listed waterbody are not eligible for coverage under this permit *unless* the operator:

1. Prevents exposing stormwater to pollutants for which the waterbody is impaired, and retains documentation in the SWPPP that details procedures taken to prevent exposure on site; *or*
2. Documents that the pollutants for which the waterbody is impaired are not present at the site, and retains documentation of this finding within the SWPPP; *or*
3. Provides Ecology with data indicating the discharge is not expected to cause or contribute to an exceedance of a water quality standard, and retains such data on site with the SWPPP. The operator must provide data and other technical information to Ecology that sufficiently demonstrate:
 - a. For discharges to waters without an EPA-approved or -established TMDL, that the discharge of the pollutant for which the water is impaired will meet in-stream water quality criteria at the point of discharge to the waterbody; *or*
 - b. For discharges to waters with an EPA-approved or -established TMDL, that there is sufficient remaining wasteload allocation in the TMDL to allow construction stormwater discharge and that existing dischargers to the waterbody are subject to compliance schedules designed to bring the waterbody into attainment with water quality standards.

Operators of construction sites are eligible for coverage under this permit only after Ecology makes an affirmative determination that the *discharge will not cause or contribute to the existing impairment or exceed the TMDL.*

C. Sampling and Numeric Effluent Limits for Discharges to Water Bodies on the 303(d) List for Turbidity, Fine Sediment, or Phosphorus

1. Permittees who discharge to segments of water bodies on the 303(d) list (Category 5) for turbidity, fine sediment, or phosphorus must conduct turbidity sampling in accordance with Special Condition S4.C.2 and comply with either of the numeric effluent limits noted in Table 5 below.
2. As an alternative to the 25 NTUs effluent limit noted in Table 5 below (applied at the point where stormwater [or authorized non-stormwater] is discharged off-site), Permittees may choose to comply with the surface water quality standard for turbidity. The standard is: no more than 5 NTUs over background turbidity when the background turbidity is 50 NTUs or less, or no more than a 10% increase in turbidity when the background turbidity is more than 50 NTUs. In order to use the water quality standard requirement, the sampling must take place at the following locations:
 - a. Background turbidity in the 303(d)-listed receiving water immediately upstream (upgradient) or outside the area of influence of the discharge.
 - b. Turbidity at the point of discharge into the 303(d)-listed receiving water, inside the area of influence of the discharge.
3. Discharges that exceed the numeric effluent limit for turbidity constitute a violation of this permit.
4. Permittees whose discharges exceed the numeric effluent limit must sample discharges daily until the violation is corrected and comply with the non-compliance notification requirements in Special Condition S5.F.

Table 5 Turbidity, Fine Sediment & Phosphorus Sampling and Limits for 303(d)-Listed Waters

Parameter identified in 303(d) listing	Parameter Sampled	Unit	Analytical Method	Sampling Frequency	Numeric Effluent Limit ¹
<ul style="list-style-type: none"> • Turbidity • Fine Sediment • Phosphorus 	Turbidity	NTU	SM2130	Weekly, if discharging	25 NTUs, at the point where stormwater is discharged from the site; <i>OR</i> In compliance with the surface water quality standard for turbidity (S8.C.2.a)

¹ Permittees subject to a numeric effluent limit for turbidity may, at their discretion, choose either numeric effluent limitation based on site-specific considerations including, but not limited to, safety, access and convenience.

D. Discharges to Water Bodies on the 303(d) List for High pH

1. Permittees who discharge to segments of water bodies on the 303(d) list (Category 5) for high pH must conduct pH sampling in accordance with the table below, and comply with the numeric effluent limit of pH 6.5 to 8.5 su (Table 6).

Table 6 pH Sampling and Limits for 303(d)-Listed Waters

Parameter identified in 303(d) listing	Parameter Sampled/Units	Analytical Method	Sampling Frequency	Numeric Effluent Limit
High pH	pH /Standard Units	pH meter	Weekly, if discharging	In the range of 6.5 – 8.5 su

2. At the Permittee’s discretion, compliance with the limit shall be assessed at one of the following locations:
 - a. Directly in the 303(d)-listed waterbody segment, inside the immediate area of influence of the discharge; *or*
 - b. Alternatively, the Permittee may measure pH at the point where the discharge leaves the construction site, rather than in the receiving water.
3. Discharges that exceed the numeric effluent limit for pH (outside the range of 6.5 – 8.5 su) constitute a violation of this permit.
4. Permittees whose discharges exceed the numeric effluent limit must sample discharges daily until the violation is corrected and comply with the non-compliance notification requirements in Special Condition S5.F.

E. Sampling and Limits for Sites Discharging to Waters Covered by a TMDL or another Pollution Control Plan

1. Discharges to a waterbody that is subject to a Total Maximum Daily Load (TMDL) for turbidity, fine sediment, high pH, or phosphorus must be consistent with the TMDL. Refer to <http://www.ecy.wa.gov/programs/wq/tmdl/TMDLsbyWria/TMDLbyWria.html> for more information on TMDLs.
 - a. Where an applicable TMDL sets specific waste load allocations or requirements for discharges covered by this permit, discharges must be consistent with any specific waste load allocations or requirements established by the applicable TMDL.
 - i. The Permittee must sample discharges weekly, unless otherwise specified by the TMDL, to evaluate compliance with the specific waste load allocations or requirements.
 - ii. Analytical methods used to meet the monitoring requirements must conform to the latest revision of the *Guidelines Establishing Test Procedures for the Analysis of Pollutants* contained in 40 CFR Part 136.
 - iii. Turbidity and pH methods need not be accredited or registered unless conducted at a laboratory which must otherwise be accredited or registered.
 - b. Where an applicable TMDL has established a general waste load allocation for construction stormwater discharges, but has not identified specific requirements, compliance with Special Conditions S4 (Monitoring) and S9 (SWPPPs) will constitute compliance with the approved TMDL.
 - c. Where an applicable TMDL has not specified a waste load allocation for construction stormwater discharges, but has not excluded these discharges, compliance with Special Conditions S4 (Monitoring) and S9 (SWPPPs) will constitute compliance with the approved TMDL.
 - d. Where an applicable TMDL specifically precludes or prohibits discharges from construction activity, the operator is not eligible for coverage under this permit.

S9. STORMWATER POLLUTION PREVENTION PLAN

The Permittee must prepare and properly implement an adequate Stormwater Pollution Prevention Plan (SWPPP) for construction activity in accordance with the requirements of this permit beginning with initial soil disturbance and until final stabilization.

A. The Permittee's SWPPP must meet the following objectives:

1. To identify best management practices (BMPs) which prevent erosion and sedimentation, and to reduce, eliminate or prevent stormwater contamination and water pollution from construction activity.
2. To prevent violations of surface water quality, groundwater quality, or sediment management standards.
3. To control peak volumetric flow rates and velocities of stormwater discharges.

B. General Requirements

1. The SWPPP must include a narrative and drawings. All BMPs must be clearly referenced in the narrative and marked on the drawings. The SWPPP narrative must include documentation to explain and justify the pollution prevention decisions made for the project. Documentation must include:
 - a. Information about existing site conditions (topography, drainage, soils, vegetation, etc.).
 - b. Potential erosion problem areas.
 - c. The 13 elements of a SWPPP in Special Condition S9.D.1-13, including BMPs used to address each element.
 - d. Construction phasing/sequence and general BMP implementation schedule.
 - e. The actions to be taken if BMP performance goals are not achieved—for example, a contingency plan for additional treatment and/or storage of stormwater that would violate the water quality standards if discharged.
 - f. Engineering calculations for ponds, treatment systems, and any other designed structures. When a treatment system requires engineering calculations, these calculations must be included in the SWPPP. Engineering calculations do not need to be included in the SWPPP for treatment systems that do not require such calculations.
2. The Permittee must modify the SWPPP if, during inspections or investigations conducted by the owner/operator, or the applicable local or state regulatory authority, it is determined that the SWPPP is, or would be, ineffective in eliminating or significantly minimizing pollutants in stormwater discharges from the site. The Permittee must then:
 - a. Review the SWPPP for compliance with Special Condition S9 and make appropriate revisions within 7 days of the inspection or investigation.
 - b. Immediately begin the process to fully implement and maintain appropriate source control and/or treatment BMPs as soon as possible, addressing the problems no later than 10 days from the inspection or investigation. If installation of necessary treatment BMPs is not feasible within 10 days, Ecology may approve additional time when an extension is requested by a Permittee within the initial 10-day response period.
 - c. Document BMP implementation and maintenance in the site log book.

The Permittee must modify the SWPPP whenever there is a change in design, construction, operation, or maintenance at the construction site that has, or could have, a significant effect on the discharge of pollutants to waters of the State.

C. Stormwater Best Management Practices (BMPs)

BMPs must be consistent with:

1. *Stormwater Management Manual for Western Washington* (most current approved edition at the time this permit was issued), for sites west of the crest of the Cascade Mountains; or

2. *Stormwater Management Manual for Eastern Washington* (most current approved edition at the time this permit was issued), for sites east of the crest of the Cascade Mountains; *or*
3. Revisions to the manuals listed in Special Condition S9.C.1 & 2, or other stormwater management guidance documents or manuals which provide an equivalent level of pollution prevention, that are approved by Ecology and incorporated into this permit in accordance with the permit modification requirements of WAC 173-226-230; *or*
4. Documentation in the SWPPP that the BMPs selected provide an equivalent level of pollution prevention, compared to the applicable stormwater management manuals, including:
 - a. The technical basis for the selection of all stormwater BMPs (scientific, technical studies, and/or modeling) that support the performance claims for the BMPs being selected.
 - b. An assessment of how the selected BMP will satisfy AKART requirements and the applicable federal technology-based treatment requirements under 40 CFR part 125.3.

D. SWPPP – Narrative Contents and Requirements

The Permittee must include each of the 13 elements below in Special Condition S9.D.1-13 in the narrative of the SWPPP and implement them unless site conditions render the element unnecessary and the exemption from that element is clearly justified in the SWPPP.

1. Preserve Vegetation/Mark Clearing Limits
 - a. Before beginning land-disturbing activities, including clearing and grading, clearly mark all clearing limits, sensitive areas and their buffers, and trees that are to be preserved within the construction area.
 - b. Retain the duff layer, native topsoil, and natural vegetation in an undisturbed state to the maximum degree practicable.
2. Establish Construction Access
 - a. Limit construction vehicle access and exit to one route, if possible.
 - b. Stabilize access points with a pad of quarry spalls, crushed rock, or other equivalent BMPs, to minimize tracking sediment onto roads.
 - c. Locate wheel wash or tire baths on site, if the stabilized construction entrance is not effective in preventing tracking sediment onto roads.
 - d. If sediment is tracked off site, clean the affected roadway thoroughly at the end of each day, or more frequently as necessary (for example, during wet weather). Remove sediment from roads by shoveling, sweeping, or pickup and transport of the sediment to a controlled sediment disposal area.
 - e. Conduct street washing only after sediment removal in accordance with Special Condition S9.D.2.d.
 - f. Control street wash wastewater by pumping back on site or otherwise preventing it from discharging into systems tributary to waters of the State.

3. Control Flow Rates

- a. Protect properties and waterways downstream of construction sites from erosion and the associated discharge of turbid waters due to increases in the velocity and peak volumetric flow rate of stormwater runoff from the project site, as required by local plan approval authority.
- b. Where necessary to comply with Special Condition S9.D.3.a, construct stormwater infiltration or detention BMPs as one of the first steps in grading. Assure that detention BMPs function properly before constructing site improvements (for example, impervious surfaces).
- c. If permanent infiltration ponds are used for flow control during construction, protect these facilities from sedimentation during the construction phase.

4. Install Sediment Controls

The Permittee must design, install and maintain effective erosion controls and sediment controls to minimize the discharge of pollutants. At a minimum, the Permittee must:

- a. Construct sediment control BMPs (sediment ponds, traps, filters, infiltration facilities, etc.) as one of the first steps in grading. These BMPs must be functional before other land disturbing activities take place.
- b. Minimize sediment discharges from the site. The design, installation and maintenance of erosion and sediment controls must address factors such as the amount, frequency, intensity and duration of precipitation, the nature of resulting stormwater runoff, and soil characteristics, including the range of soil particle sizes expected to be present on the site.
- c. Direct stormwater runoff from disturbed areas through a sediment pond or other appropriate sediment removal BMP, before the runoff leaves a construction site or before discharge to an infiltration facility. Runoff from fully stabilized areas may be discharged without a sediment removal BMP, but must meet the flow control performance standard of Special Condition S9.D.3.a.
- d. Locate BMPs intended to trap sediment on site in a manner to avoid interference with the movement of juvenile salmonids attempting to enter off-channel areas or drainages.
- e. Provide and maintain natural buffers around surface waters, direct stormwater to vegetated areas to increase sediment removal and maximize stormwater infiltration, unless infeasible.
- f. Where feasible, design outlet structures that withdraw impounded stormwater from the surface to avoid discharging sediment that is still suspended lower in the water column.

5. Stabilize Soils

- a. The Permittee must stabilize exposed and unworked soils by application of effective BMPs that prevent erosion. Applicable BMPs include, but are not limited to: temporary and permanent seeding, sodding, mulching, plastic covering, erosion

control fabrics and matting, soil application of polyacrylamide (PAM), the early application of gravel base on areas to be paved, and dust control.

- b. The Permittee must control stormwater volume and velocity within the site to minimize soil erosion.
- c. The Permittee must control stormwater discharges, including both peak flow rates and total stormwater volume, to minimize erosion at outlets and to minimize downstream channel and stream bank erosion.
- d. Depending on the geographic location of the project, the Permittee must not allow soils to remain exposed and unworked for more than the time periods set forth below to prevent erosion.

West of the Cascade Mountains Crest

During the dry season (May 1 - September 30): 7 days

During the wet season (October 1 - April 30): 2 days

East of the Cascade Mountains Crest, except for Central Basin*

During the dry season (July 1 - September 30): 10 days

During the wet season (October 1 - June 30): 5 days

The Central Basin*, East of the Cascade Mountains Crest

During the dry Season (July 1 - September 30): 30 days

During the wet season (October 1 - June 30): 15 days

***Note: The Central Basin** is defined as the portions of Eastern Washington with mean annual precipitation of less than 12 inches.

- e. The Permittee must stabilize soils at the end of the shift before a holiday or weekend if needed based on the weather forecast.
- f. The Permittee must stabilize soil stockpiles from erosion, protected with sediment trapping measures, and where possible, be located away from storm drain inlets, waterways, and drainage channels.
- g. The Permittee must minimize the amount of soil exposed during construction activity.
- h. The Permittee must minimize the disturbance of steep slopes.
- i. The Permittee must minimize soil compaction and, unless infeasible, preserve topsoil.

6. Protect Slopes

- a. The Permittee must design and construct cut-and-fill slopes in a manner to minimize erosion. Applicable practices include, but are not limited to, reducing continuous length of slope with terracing and diversions, reducing slope steepness, and roughening slope surfaces (for example, track walking).
- b. The Permittee must divert off-site stormwater (run-on) or groundwater away from slopes and disturbed areas with interceptor dikes, pipes, and/or swales. Off-site stormwater should be managed separately from stormwater generated on the site.
- c. At the top of slopes, collect drainage in pipe slope drains or protected channels to prevent erosion.

- i. West of the Cascade Mountains Crest: Temporary pipe slope drains must handle the peak 10-minute flow rate from a Type 1A, 10-year, 24-hour frequency storm for the developed condition. Alternatively, the 10-year, 1-hour flow rate predicted by an approved continuous runoff model, increased by a factor of 1.6, may be used. The hydrologic analysis must use the existing land cover condition for predicting flow rates from tributary areas outside the project limits. For tributary areas on the project site, the analysis must use the temporary or permanent project land cover condition, whichever will produce the highest flow rates. If using the Western Washington Hydrology Model (WWHM) to predict flows, bare soil areas should be modeled as "landscaped area."
 - ii. East of the Cascade Mountains Crest: Temporary pipe slope drains must handle the expected peak flow rate from a 6-month, 3-hour storm for the developed condition, referred to as the short duration storm.
 - d. Place excavated material on the uphill side of trenches, consistent with safety and space considerations.
 - e. Place check dams at regular intervals within constructed channels that are cut down a slope.
7. Protect Drain Inlets
- a. Protect all storm drain inlets made operable during construction so that stormwater runoff does not enter the conveyance system without first being filtered or treated to remove sediment.
 - b. Clean or remove and replace inlet protection devices when sediment has filled one-third of the available storage (unless a different standard is specified by the product manufacturer).
8. Stabilize Channels and Outlets
- a. Design, construct and stabilize all on-site conveyance channels to prevent erosion from the following expected peak flows:
 - i. West of the Cascade Mountains Crest: Channels must handle the peak 10-minute flow rate from a Type 1A, 10-year, 24-hour frequency storm for the developed condition. Alternatively, the 10-year, 1-hour flow rate indicated by an approved continuous runoff model, increased by a factor of 1.6, may be used. The hydrologic analysis must use the existing land cover condition for predicting flow rates from tributary areas outside the project limits. For tributary areas on the project site, the analysis must use the temporary or permanent project land cover condition, whichever will produce the highest flow rates. If using the WWHM to predict flows, bare soil areas should be modeled as "landscaped area."
 - ii. East of the Cascade Mountains Crest: Channels must handle the expected peak flow rate from a 6-month, 3-hour storm for the developed condition, referred to as the short duration storm.
 - b. Provide stabilization, including armoring material, adequate to prevent erosion of outlets, adjacent stream banks, slopes, and downstream reaches at the outlets of all conveyance systems.

9. Control Pollutants

Design, install, implement and maintain effective pollution prevention measures to minimize the discharge of pollutants. The Permittee must:

- a. Handle and dispose of all pollutants, including waste materials and demolition debris that occur on site in a manner that does not cause contamination of stormwater.
- b. Provide cover, containment, and protection from vandalism for all chemicals, liquid products, petroleum products, and other materials that have the potential to pose a threat to human health or the environment. Minimize storage of hazardous materials on-site. Safety Data Sheets (SDS) should be supplied for all materials stored. Chemicals should be kept in their original labeled containers. On-site fueling tanks must include secondary containment. Secondary containment means placing tanks or containers within an impervious structure capable of containing 110% of the volume of the largest tank within the containment structure. Double-walled tanks do not require additional secondary containment.
- c. Conduct maintenance, fueling, and repair of heavy equipment and vehicles using spill prevention and control measures. Clean contaminated surfaces immediately following any spill incident.
- d. Discharge wheel wash or tire bath wastewater to a separate on-site treatment system that prevents discharge to surface water, such as closed-loop recirculation or upland land application, or to the sanitary sewer with local sewer district approval.
- e. Apply fertilizers and pesticides in a manner and at application rates that will not result in loss of chemical to stormwater runoff. Follow manufacturers' label requirements for application rates and procedures.
- f. Use BMPs to prevent contamination of stormwater runoff by pH-modifying sources. The sources for this contamination include, but are not limited to: bulk cement, cement kiln dust, fly ash, new concrete washing and curing waters, recycled concrete stockpiles, waste streams generated from concrete grinding and sawing, exposed aggregate processes, dewatering concrete vaults, concrete pumping and mixer washout waters. (Also refer to the definition for "concrete wastewater" in Appendix A – Definitions.)
- g. Adjust the pH of stormwater or authorized non-stormwater if necessary to prevent an exceedance of groundwater and/or surface water quality standards.
- h. Assure that washout of concrete trucks is performed off-site or in designated concrete washout areas only. Do not wash out concrete truck drums onto the ground, or into storm drains, open ditches, streets, or streams. Washout of small concrete handling equipment may be disposed of in a formed area awaiting concrete where it will not contaminate surface or groundwater. Do not dump excess concrete on site, except in designated concrete washout areas. Concrete spillage or concrete discharge directly to groundwater or surface waters of the State is

prohibited. At no time shall concrete be washed off into the footprint of an area where an infiltration BMP will be installed.

- i. Obtain written approval from Ecology before using any chemical treatment, with the exception of CO₂, dry ice or food grade vinegar, to adjust pH.
- j. Uncontaminated water from water-only based shaft drilling for construction of building, road, and bridge foundations may be infiltrated provided the wastewater is managed in a way that prohibits discharge to surface waters. Prior to infiltration, water from water-only based shaft drilling that comes into contact with curing concrete must be neutralized until pH is in the range of 6.5 to 8.5 (su).

10. Control Dewatering

- a. Permittees must discharge foundation, vault, and trench dewatering water, which have characteristics similar to stormwater runoff at the site, in conjunction with BMPs to reduce sedimentation before discharge to a sediment trap or sediment pond.
- b. Permittees may discharge clean, non-turbid dewatering water, such as well-point groundwater, to systems tributary to, or directly into surface waters of the State, as specified in Special Condition S9.D.8, provided the dewatering flow does not cause erosion or flooding of receiving waters. Do not route clean dewatering water through stormwater sediment ponds. Note that "surface waters of the State" may exist on a construction site as well as off site; for example, a creek running through a site.
- c. Other dewatering treatment or disposal options may include:
 - i. Infiltration
 - ii. Transport off site in a vehicle, such as a vacuum flush truck, for legal disposal in a manner that does not pollute state waters.
 - iii. Ecology-approved on-site chemical treatment or other suitable treatment technologies (See S9.D.9.i, regarding chemical treatment written approval).
 - iv. Sanitary or combined sewer discharge with local sewer district approval, if there is no other option.
 - v. Use of a sedimentation bag with discharge to a ditch or swale for small volumes of localized dewatering.
- d. Permittees must handle highly turbid or contaminated dewatering water separately from stormwater.

11. Maintain BMPs

- a. Permittees must maintain and repair all temporary and permanent erosion and sediment control BMPs as needed to assure continued performance of their intended function in accordance with BMP specifications.
- b. Permittees must remove all temporary erosion and sediment control BMPs within 30 days after achieving final site stabilization or after the temporary BMPs are no longer needed.

12. Manage the Project

- a. Phase development projects to the maximum degree practicable and take into account seasonal work limitations.
- b. Inspect, maintain and repair all BMPs as needed to assure continued performance of their intended function. Conduct site inspections and monitoring in accordance with Special Condition S4.
- c. Maintain, update, and implement the SWPPP in accordance with Special Conditions S3, S4, and S9.

13. Protect Low Impact Development (LID) BMPs

The primary purpose of on-site LID Stormwater Management is to reduce the disruption of the natural site hydrology through infiltration. LID BMPs are permanent facilities.

- a. Permittees must protect all LID BMPs (including, but not limited to, Bioretention and Rain Garden facilities) from sedimentation through installation and maintenance of erosion and sediment control BMPs on portions of the site that drain into the Bioretention and/or Rain Garden facilities. Restore the BMPs to their fully functioning condition if they accumulate sediment during construction. Restoring the facility must include removal of sediment and any sediment-laden bioretention/ rain garden soils, and replacing the removed soils with soils meeting the design specification.
- b. Permittees must maintain the infiltration capabilities of LID BMPs by protecting against compaction by construction equipment and foot traffic. Protect completed lawn and landscaped areas from compaction due to construction equipment.
- c. Permittees must control erosion and avoid introducing sediment from surrounding land uses onto permeable pavements. Do not allow muddy construction equipment on the base material or pavement. Do not allow sediment-laden runoff onto permeable pavements or base materials.
- d. Permittees must clean permeable pavements fouled with sediments or no longer passing an initial infiltration test using local stormwater manual methodology or the manufacturer's procedures.
- e. Permittees must keep all heavy equipment off existing soils under LID BMPs that have been excavated to final grade to retain the infiltration rate of the soils.

E. SWPPP – Map Contents and Requirements

The Permittee's SWPPP must also include a vicinity map or general location map (for example, a USGS quadrangle map, a portion of a county or city map, or other appropriate map) with enough detail to identify the location of the construction site and receiving waters within one mile of the site.

The SWPPP must also include a legible site map (or maps) showing the entire construction site. The following features must be identified, unless not applicable due to site conditions.

1. The direction of north, property lines, and existing structures and roads.
2. Cut and fill slopes indicating the top and bottom of slope catch lines.

3. Approximate slopes, contours, and direction of stormwater flow before and after major grading activities.
4. Areas of soil disturbance and areas that will not be disturbed.
5. Locations of structural and nonstructural controls (BMPs) identified in the SWPPP.
6. Locations of off-site material, stockpiles, waste storage, borrow areas, and vehicle/equipment storage areas.
7. Locations of all surface water bodies, including wetlands.
8. Locations where stormwater or non-stormwater discharges off-site and/or to a surface waterbody, including wetlands.
9. Location of water quality sampling station(s), if sampling is required by state or local permitting authority.
10. Areas where final stabilization has been accomplished and no further construction-phase permit requirements apply.
11. Location or proposed location of LID facilities.

S10. NOTICE OF TERMINATION

Partial terminations of permit coverage are not authorized.

- A.** The site is eligible for termination of coverage when it has met any of the following conditions:
 1. The site has undergone final stabilization, the Permittee has removed all temporary BMPs (except biodegradable BMPs clearly manufactured with the intention for the material to be left in place and not interfere with maintenance or land use), and all stormwater discharges associated with construction activity have been eliminated; *or*
 2. All portions of the site that have not undergone final stabilization per Special Condition S10.A.1 have been sold and/or transferred (per Special Condition S2.A), and the Permittee no longer has operational control of the construction activity; *or*
 3. For residential construction only, the Permittee has completed temporary stabilization and the homeowners have taken possession of the residences.
- B.** When the site is eligible for termination, the Permittee must submit a complete and accurate Notice of Termination (NOT) form, signed in accordance with General Condition G2, to:

Department of Ecology
Water Quality Program - Construction Stormwater
PO Box 47696
Olympia, WA 98504-7696

When an electronic termination form is available, the Permittee may choose to submit a complete and accurate Notice of Termination (NOT) form through the Water Quality Permitting Portal rather than mailing a hardcopy as noted above.

The termination is effective on the 31st calendar day following the date Ecology receives a complete NOT form, unless Ecology notifies the Permittee that termination request is denied because the Permittee has not met the eligibility requirements in Special Condition S10.A.

Permittees are required to comply with all conditions and effluent limitations in the permit until the permit has been terminated.

Permittees transferring the property to a new property owner or operator/Permittee are required to complete and submit the Notice of Transfer form to Ecology, but are not required to submit a Notice of Termination form for this type of transaction.

GENERAL CONDITIONS

G1. DISCHARGE VIOLATIONS

All discharges and activities authorized by this general permit must be consistent with the terms and conditions of this general permit. Any discharge of any pollutant more frequent than or at a level in excess of that identified and authorized by the general permit must constitute a violation of the terms and conditions of this permit.

G2. SIGNATORY REQUIREMENTS

- A.** All permit applications must bear a certification of correctness to be signed:
1. In the case of corporations, by a responsible corporate officer.
 2. In the case of a partnership, by a general partner of a partnership.
 3. In the case of sole proprietorship, by the proprietor.
 4. In the case of a municipal, state, or other public facility, by either a principal executive officer or ranking elected official.
- B.** All reports required by this permit and other information requested by Ecology (including NOIs, NOTs, and Transfer of Coverage forms) must be signed by a person described above or by a duly authorized representative of that person. A person is a duly authorized representative only if:
1. The authorization is made in writing by a person described above and submitted to Ecology.
 2. The authorization specifies either an individual or a position having responsibility for the overall operation of the regulated facility, such as the position of plant manager, superintendent, position of equivalent responsibility, or an individual or position having overall responsibility for environmental matters.
- C.** Changes to authorization. If an authorization under paragraph G2.B.2 above is no longer accurate because a different individual or position has responsibility for the overall operation of the facility, a new authorization satisfying the requirements of paragraph G2.B.2 above must be submitted to Ecology prior to or together with any reports, information, or applications to be signed by an authorized representative.
- D.** Certification. Any person signing a document under this section must make the following certification:

I certify under penalty of law, that this document and all attachments were prepared under my direction or supervision in accordance with a system designed to assure that qualified personnel properly gathered and evaluated the information submitted. Based on my inquiry of the person or persons who manage the system, or those persons directly responsible for gathering information, the information submitted is, to the best of my knowledge and belief, true, accurate, and complete. I am aware that there are significant penalties for submitting false information, including the possibility of fine and imprisonment for knowing violations.

G3. RIGHT OF INSPECTION AND ENTRY

The Permittee must allow an authorized representative of Ecology, upon the presentation of credentials and such other documents as may be required by law:

- A.** To enter upon the premises where a discharge is located or where any records are kept under the terms and conditions of this permit.
- B.** To have access to and copy, at reasonable times and at reasonable cost, any records required to be kept under the terms and conditions of this permit.
- C.** To inspect, at reasonable times, any facilities, equipment (including monitoring and control equipment), practices, methods, or operations regulated or required under this permit.
- D.** To sample or monitor, at reasonable times, any substances or parameters at any location for purposes of assuring permit compliance or as otherwise authorized by the Clean Water Act.

G4. GENERAL PERMIT MODIFICATION AND REVOCATION

This permit may be modified, revoked and reissued, or terminated in accordance with the provisions of Chapter 173-226 WAC. Grounds for modification, revocation and reissuance, or termination include, but are not limited to, the following:

- A.** When a change occurs in the technology or practices for control or abatement of pollutants applicable to the category of dischargers covered under this permit.
- B.** When effluent limitation guidelines or standards are promulgated pursuant to the CWA or Chapter 90.48 RCW, for the category of dischargers covered under this permit.
- C.** When a water quality management plan containing requirements applicable to the category of dischargers covered under this permit is approved, or
- D.** When information is obtained that indicates cumulative effects on the environment from dischargers covered under this permit are unacceptable.

G5. REVOCATION OF COVERAGE UNDER THE PERMIT

Pursuant to Chapter 43.21B RCW and Chapter 173-226 WAC, the Director may terminate coverage for any discharger under this permit for cause. Cases where coverage may be terminated include, but are not limited to, the following:

- A.** Violation of any term or condition of this permit.
- B.** Obtaining coverage under this permit by misrepresentation or failure to disclose fully all relevant facts.
- C.** A change in any condition that requires either a temporary or permanent reduction or elimination of the permitted discharge.
- D.** Failure or refusal of the Permittee to allow entry as required in RCW 90.48.090.
- E.** A determination that the permitted activity endangers human health or the environment, or contributes to water quality standards violations.
- F.** Nonpayment of permit fees or penalties assessed pursuant to RCW 90.48.465 and Chapter 173-224 WAC.

- G.** Failure of the Permittee to satisfy the public notice requirements of WAC 173-226-130(5), when applicable.

The Director may require any discharger under this permit to apply for and obtain coverage under an individual permit or another more specific general permit. Permittees who have their coverage revoked for cause according to WAC 173-226-240 may request temporary coverage under this permit during the time an individual permit is being developed, provided the request is made within ninety (90) days from the time of revocation and is submitted along with a complete individual permit application form.

G6. REPORTING A CAUSE FOR MODIFICATION

The Permittee must submit a new application, or a supplement to the previous application, whenever a material change to the construction activity or in the quantity or type of discharge is anticipated which is not specifically authorized by this permit. This application must be submitted at least sixty (60) days prior to any proposed changes. Filing a request for a permit modification, revocation and reissuance, or termination, or a notification of planned changes or anticipated noncompliance does not relieve the Permittee of the duty to comply with the existing permit until it is modified or reissued.

G7. COMPLIANCE WITH OTHER LAWS AND STATUTES

Nothing in this permit will be construed as excusing the Permittee from compliance with any applicable federal, state, or local statutes, ordinances, or regulations.

G8. DUTY TO REAPPLY

The Permittee must apply for permit renewal at least 180 days prior to the specified expiration date of this permit. The Permittee must reapply using the electronic application form (NOI) available on Ecology's website. Permittees unable to submit electronically (for example, those who do not have an internet connection) must contact Ecology to request a waiver and obtain instructions on how to obtain a paper NOI.

Department of Ecology
Water Quality Program - Construction Stormwater
PO Box 47696
Olympia, WA 98504-7696

G9. REMOVED SUBSTANCE

The Permittee must not re-suspend or reintroduce collected screenings, grit, solids, sludges, filter backwash, or other pollutants removed in the course of treatment or control of stormwater to the final effluent stream for discharge to state waters.

G10. DUTY TO PROVIDE INFORMATION

The Permittee must submit to Ecology, within a reasonable time, all information that Ecology may request to determine whether cause exists for modifying, revoking and reissuing, or terminating this permit or to determine compliance with this permit. The Permittee must also submit to Ecology, upon request, copies of records required to be kept by this permit [40 CFR 122.41(h)].

G11. OTHER REQUIREMENTS OF 40 CFR

All other requirements of 40 CFR 122.41 and 122.42 are incorporated in this permit by reference.

G12. ADDITIONAL MONITORING

Ecology may establish specific monitoring requirements in addition to those contained in this permit by administrative order or permit modification.

G13. PENALTIES FOR VIOLATING PERMIT CONDITIONS

Any person who is found guilty of willfully violating the terms and conditions of this permit shall be deemed guilty of a crime, and upon conviction thereof shall be punished by a fine of up to ten thousand dollars (\$10,000) and costs of prosecution, or by imprisonment at the discretion of the court. Each day upon which a willful violation occurs may be deemed a separate and additional violation.

Any person who violates the terms and conditions of a waste discharge permit shall incur, in addition to any other penalty as provided by law, a civil penalty in the amount of up to ten thousand dollars (\$10,000) for every such violation. Each and every such violation shall be a separate and distinct offense, and in case of a continuing violation, every day's continuance shall be deemed to be a separate and distinct violation.

G14. UPSET

Definition – "Upset" means an exceptional incident in which there is unintentional and temporary noncompliance with technology-based permit effluent limitations because of factors beyond the reasonable control of the Permittee. An upset does not include noncompliance to the extent caused by operational error, improperly designed treatment facilities, inadequate treatment facilities, lack of preventive maintenance, or careless or improper operation.

An upset constitutes an affirmative defense to an action brought for noncompliance with such technology-based permit effluent limitations if the requirements of the following paragraph are met.

A Permittee who wishes to establish the affirmative defense of upset must demonstrate, through properly signed, contemporaneous operating logs or other relevant evidence that: 1) an upset occurred and that the Permittee can identify the cause(s) of the upset; 2) the permitted facility was being properly operated at the time of the upset; 3) the Permittee submitted notice of the upset as required in Special Condition S5.F, and; 4) the Permittee complied with any remedial measures required under this permit.

In any enforcement proceeding, the Permittee seeking to establish the occurrence of an upset has the burden of proof.

G15. PROPERTY RIGHTS

This permit does not convey any property rights of any sort, or any exclusive privilege.

G16. DUTY TO COMPLY

The Permittee must comply with all conditions of this permit. Any permit noncompliance constitutes a violation of the Clean Water Act and is grounds for enforcement action; for permit termination, revocation and reissuance, or modification; or denial of a permit renewal application.

G17. TOXIC POLLUTANTS

The Permittee must comply with effluent standards or prohibitions established under Section 307(a) of the Clean Water Act for toxic pollutants within the time provided in the regulations that establish those standards or prohibitions, even if this permit has not yet been modified to incorporate the requirement.

G18. PENALTIES FOR TAMPERING

The Clean Water Act provides that any person who falsifies, tampers with, or knowingly renders inaccurate any monitoring device or method required to be maintained under this permit shall, upon conviction, be punished by a fine of not more than \$10,000 per violation, or by imprisonment for not more than two years per violation, or by both. If a conviction of a person is for a violation committed after a first conviction of such person under this condition, punishment shall be a fine of not more than \$20,000 per day of violation, or imprisonment of not more than four (4) years, or both.

G19. REPORTING PLANNED CHANGES

The Permittee must, as soon as possible, give notice to Ecology of planned physical alterations, modifications or additions to the permitted construction activity. The Permittee should be aware that, depending on the nature and size of the changes to the original permit, a new public notice and other permit process requirements may be required. Changes in activities that require reporting to Ecology include those that will result in:

- A.** The permitted facility being determined to be a new source pursuant to 40 CFR 122.29(b).
- B.** A significant change in the nature or an increase in quantity of pollutants discharged, including but not limited to: a 20% or greater increase in acreage disturbed by construction activity.
- C.** A change in or addition of surface water(s) receiving stormwater or non-stormwater from the construction activity.
- D.** A change in the construction plans and/or activity that affects the Permittee's monitoring requirements in Special Condition S4.

Following such notice, permit coverage may be modified, or revoked and reissued pursuant to 40 CFR 122.62(a) to specify and limit any pollutants not previously limited. Until such modification is effective, any new or increased discharge in excess of permit limits or not specifically authorized by this permit constitutes a violation.

G20. REPORTING OTHER INFORMATION

Where the Permittee becomes aware that it failed to submit any relevant facts in a permit application, or submitted incorrect information in a permit application or in any report to Ecology, it must promptly submit such facts or information.

G21. REPORTING ANTICIPATED NON-COMPLIANCE

The Permittee must give advance notice to Ecology by submission of a new application or supplement thereto at least forty-five (45) days prior to commencement of such discharges, of any facility expansions, production increases, or other planned changes, such as process modifications, in the permitted facility or activity which may result in noncompliance with permit limits or conditions. Any maintenance of facilities, which might necessitate unavoidable interruption of

operation and degradation of effluent quality, must be scheduled during non-critical water quality periods and carried out in a manner approved by Ecology.

G22. REQUESTS TO BE EXCLUDED FROM COVERAGE UNDER THE PERMIT

Any discharger authorized by this permit may request to be excluded from coverage under the general permit by applying for an individual permit. The discharger must submit to the Director an application as described in WAC 173-220-040 or WAC 173-216-070, whichever is applicable, with reasons supporting the request. These reasons will fully document how an individual permit will apply to the applicant in a way that the general permit cannot. Ecology may make specific requests for information to support the request. The Director will either issue an individual permit or deny the request with a statement explaining the reason for the denial. When an individual permit is issued to a discharger otherwise subject to the construction stormwater general permit, the applicability of the construction stormwater general permit to that Permittee is automatically terminated on the effective date of the individual permit.

G23. APPEALS

- A.** The terms and conditions of this general permit, as they apply to the appropriate class of dischargers, are subject to appeal by any person within 30 days of issuance of this general permit, in accordance with Chapter 43.21B RCW, and Chapter 173-226 WAC.
- B.** The terms and conditions of this general permit, as they apply to an individual discharger, are appealable in accordance with Chapter 43.21B RCW within 30 days of the effective date of coverage of that discharger. Consideration of an appeal of general permit coverage of an individual discharger is limited to the general permit's applicability or nonapplicability to that individual discharger.
- C.** The appeal of general permit coverage of an individual discharger does not affect any other dischargers covered under this general permit. If the terms and conditions of this general permit are found to be inapplicable to any individual discharger(s), the matter shall be remanded to Ecology for consideration of issuance of an individual permit or permits.

G24. SEVERABILITY

The provisions of this permit are severable, and if any provision of this permit, or application of any provision of this permit to any circumstance, is held invalid, the application of such provision to other circumstances, and the remainder of this permit shall not be affected thereby.

G25. BYPASS PROHIBITED

A. Bypass Procedures

Bypass, which is the intentional diversion of waste streams from any portion of a treatment facility, is prohibited for stormwater events below the design criteria for stormwater management. Ecology may take enforcement action against a Permittee for bypass unless one of the following circumstances (1, 2, 3 or 4) is applicable.

- 1. Bypass of stormwater is consistent with the design criteria and part of an approved management practice in the applicable stormwater management manual.
- 2. Bypass for essential maintenance without the potential to cause violation of permit limits or conditions.

Bypass is authorized if it is for essential maintenance and does not have the potential to cause violations of limitations or other conditions of this permit, or adversely impact public health.

3. Bypass of stormwater is unavoidable, unanticipated, and results in noncompliance of this permit.

This bypass is permitted only if:

- a. Bypass is unavoidable to prevent loss of life, personal injury, or severe property damage. "Severe property damage" means substantial physical damage to property, damage to the treatment facilities which would cause them to become inoperable, or substantial and permanent loss of natural resources which can reasonably be expected to occur in the absence of a bypass.
 - b. There are no feasible alternatives to the bypass, such as the use of auxiliary treatment facilities, retention of untreated wastes, maintenance during normal periods of equipment downtime (but not if adequate backup equipment should have been installed in the exercise of reasonable engineering judgment to prevent a bypass which occurred during normal periods of equipment downtime or preventative maintenance), or transport of untreated wastes to another treatment facility.
 - c. Ecology is properly notified of the bypass as required in Special Condition S5.F of this permit.
4. A planned action that would cause bypass of stormwater and has the potential to result in noncompliance of this permit during a storm event.

The Permittee must notify Ecology at least thirty (30) days before the planned date of bypass. The notice must contain:

- a. A description of the bypass and its cause
 - b. An analysis of all known alternatives which would eliminate, reduce, or mitigate the need for bypassing.
 - c. A cost-effectiveness analysis of alternatives including comparative resource damage assessment.
 - d. The minimum and maximum duration of bypass under each alternative.
 - e. A recommendation as to the preferred alternative for conducting the bypass.
 - f. The projected date of bypass initiation.
 - g. A statement of compliance with SEPA.
 - h. A request for modification of water quality standards as provided for in WAC 173-201A-110, if an exceedance of any water quality standard is anticipated.
 - i. Steps taken or planned to reduce, eliminate, and prevent reoccurrence of the bypass.
5. For probable construction bypasses, the need to bypass is to be identified as early in the planning process as possible. The analysis required above must be considered during

preparation of the Stormwater Pollution Prevention Plan (SWPPP) and must be included to the extent practical. In cases where the probable need to bypass is determined early, continued analysis is necessary up to and including the construction period in an effort to minimize or eliminate the bypass.

Ecology will consider the following before issuing an administrative order for this type bypass:

- a. If the bypass is necessary to perform construction or maintenance-related activities essential to meet the requirements of this permit.
- b. If there are feasible alternatives to bypass, such as the use of auxiliary treatment facilities, retention of untreated wastes, stopping production, maintenance during normal periods of equipment down time, or transport of untreated wastes to another treatment facility.
- c. If the bypass is planned and scheduled to minimize adverse effects on the public and the environment.

After consideration of the above and the adverse effects of the proposed bypass and any other relevant factors, Ecology will approve, conditionally approve, or deny the request. The public must be notified and given an opportunity to comment on bypass incidents of significant duration, to the extent feasible. Approval of a request to bypass will be by administrative order issued by Ecology under RCW 90.48.120.

B. Duty to Mitigate

The Permittee is required to take all reasonable steps to minimize or prevent any discharge or sludge use or disposal in violation of this permit that has a reasonable likelihood of adversely affecting human health or the environment.

APPENDIX A – DEFINITIONS

AKART is an acronym for “All Known, Available, and Reasonable methods of prevention, control, and Treatment.” AKART represents the most current methodology that can be reasonably required for preventing, controlling, or abating the pollutants and controlling pollution associated with a discharge.

Applicable TMDL means a TMDL for turbidity, fine sediment, high pH, or phosphorus, which was completed and approved by EPA before January 1, 2021, or before the date the operator’s complete permit application is received by Ecology, whichever is later. TMDLs completed after a complete permit application is received by Ecology become applicable to the Permittee only if they are imposed through an administrative order by Ecology, or through a modification of permit coverage.

Applicant means an *operator* seeking coverage under this permit.

Benchmark means a pollutant concentration used as a permit threshold, below which a pollutant is considered unlikely to cause a water quality violation, and above which it may. When pollutant concentrations exceed benchmarks, corrective action requirements take effect. Benchmark values are not water quality standards and are not numeric effluent limitations; they are indicator values.

Best Management Practices (BMPs) means schedules of activities, prohibitions of practices, maintenance procedures, and other physical, structural and/or managerial practices to prevent or reduce the pollution of waters of the State. BMPs include treatment systems, operating procedures, and practices to control stormwater associated with construction activity, spillage or leaks, sludge or waste disposal, or drainage from raw material storage.

Buffer means an area designated by a local jurisdiction that is contiguous to and intended to protect a sensitive area.

Bypass means the intentional diversion of waste streams from any portion of a treatment facility.

Calendar Day A period of 24 consecutive hours starting at 12:00 midnight and ending the following 12:00 midnight.

Calendar Week (same as **Week**) means a period of seven consecutive days starting at 12:01 a.m. (0:01 hours) on Sunday.

Certified Erosion and Sediment Control Lead (CESCL) means a person who has current certification through an approved erosion and sediment control training program that meets the minimum training standards established by Ecology (See BMP C160 in the SWMM).

Chemical Treatment means the addition of chemicals to stormwater and/or authorized non-stormwater prior to filtration and discharge to surface waters.

Clean Water Act (CWA) means the Federal Water Pollution Control Act enacted by Public Law 92-500, as amended by Public Laws 95-217, 95-576, 96-483, and 97-117; USC 1251 et seq.

Combined Sewer means a sewer which has been designed to serve as a sanitary sewer and a storm sewer, and into which inflow is allowed by local ordinance.

Common Plan of Development or Sale means a site where multiple separate and distinct construction activities may be taking place at different times on different schedules and/or by different contractors, but still under a single plan. Examples include: 1) phased projects and projects with multiple filings or lots, even if the separate phases or filings/lots will be constructed under separate contract or by separate owners (e.g., a development where lots are sold to separate builders); 2) a development plan that may be phased over multiple years, but is still under a consistent plan for long-term development; 3) projects in a contiguous area that may be unrelated but still under the same contract, such as construction of a building extension and a new parking lot at the same facility; and 4) linear projects such as roads, pipelines, or utilities. If the project is part of a common plan of development or sale, the disturbed area of the entire plan must be used in determining permit requirements.

Composite Sample means a mixture of grab samples collected at the same sampling point at different times, formed either by continuous sampling or by mixing discrete samples. May be "time-composite" (collected at constant time intervals) or "flow-proportional" (collected either as a constant sample volume at time intervals proportional to stream flow, or collected by increasing the volume of each aliquot as the flow increases while maintaining a constant time interval between the aliquots).

Concrete Wastewater means any water used in the production, pouring and/or clean-up of concrete or concrete products, and any water used to cut, grind, wash, or otherwise modify concrete or concrete products. Examples include water used for or resulting from concrete truck/mixer/pumper/tool/chute rinsing or washing, concrete saw cutting and surfacing (sawing, coring, grinding, roughening, hydro-demolition, bridge and road surfacing). When stormwater combines with concrete wastewater, the resulting water is considered concrete wastewater and must be managed to prevent discharge to waters of the State, including groundwater.

Construction Activity means land disturbing operations including clearing, grading or excavation which disturbs the surface of the land (including off-site disturbance acreage related to construction-support activity). Such activities may include road construction, construction of residential houses, office buildings, or industrial buildings, site preparation, soil compaction, movement and stockpiling of topsoils, and demolition activity.

Construction Support Activity means off-site acreage that will be disturbed as a direct result of the construction project and will discharge stormwater. For example, off-site equipment staging yards, material storage areas, borrow areas, and parking areas.

Contaminant means any hazardous substance that does not occur naturally or occurs at greater than natural background levels. See definition of "hazardous substance" and WAC 173-340-200.

Contaminated soil means soil which contains contaminants, pollutants, or hazardous substances that do not occur naturally or occur at levels greater than natural background.

Contaminated groundwater means groundwater which contains contaminants, pollutants, or hazardous substances that do not occur naturally or occur at levels greater than natural background.

Demonstrably Equivalent means that the technical basis for the selection of all stormwater BMPs is documented within a SWPPP, including:

1. The method and reasons for choosing the stormwater BMPs selected.
2. The pollutant removal performance expected from the BMPs selected.

3. The technical basis supporting the performance claims for the BMPs selected, including any available data concerning field performance of the BMPs selected.
4. An assessment of how the selected BMPs will comply with state water quality standards.
5. An assessment of how the selected BMPs will satisfy both applicable federal technology-based treatment requirements and state requirements to use all known, available, and reasonable methods of prevention, control, and treatment (AKART).

Department means the Washington State Department of Ecology.

Detention means the temporary storage of stormwater to improve quality and/or to reduce the mass flow rate of discharge.

Dewatering means the act of pumping groundwater or stormwater away from an active construction site.

Director means the Director of the Washington State Department of Ecology or his/her authorized representative.

Discharger means an owner or operator of any facility or activity subject to regulation under Chapter 90.48 RCW or the Federal Clean Water Act.

Domestic Wastewater means water carrying human wastes, including kitchen, bath, and laundry wastes from residences, buildings, industrial establishments, or other places, together with such groundwater infiltration or surface waters as may be present.

Ecology means the Washington State Department of Ecology.

Engineered Soils means the use of soil amendments including, but not limited, to Portland cement treated base (CTB), cement kiln dust (CKD), or fly ash to achieve certain desirable soil characteristics.

Equivalent BMPs means operational, source control, treatment, or innovative BMPs which result in equal or better quality of stormwater discharge to surface water or to groundwater than BMPs selected from the SWMM.

Erosion means the wearing away of the land surface by running water, wind, ice, or other geological agents, including such processes as gravitational creep.

Erosion and Sediment Control BMPs means BMPs intended to prevent erosion and sedimentation, such as preserving natural vegetation, seeding, mulching and matting, plastic covering, filter fences, sediment traps, and ponds. Erosion and sediment control BMPs are synonymous with stabilization and structural BMPs.

Federal Operator is an entity that meets the definition of "Operator" in this permit and is either any department, agency or instrumentality of the executive, legislative, and judicial branches of the Federal government of the United States, or another entity, such as a private contractor, performing construction activity for any such department, agency, or instrumentality.

Final Stabilization (same as **fully stabilized** or **full stabilization**) means the completion of all soil disturbing activities at the site and the establishment of permanent vegetative cover, or equivalent permanent stabilization measures (such as pavement, riprap, gabions, or geotextiles) which will prevent erosion. See the applicable Stormwater Management Manual for more information on vegetative cover expectations and equivalent permanent stabilization measures.

Groundwater means water in a saturated zone or stratum beneath the land surface or a surface waterbody.

Hazardous Substance means any dangerous or extremely hazardous waste as defined in RCW 70.105.010 (5) and (6), or any dangerous or extremely dangerous waste as designated by rule under chapter 70.105 RCW; any hazardous substance as defined in RCW 70.105.010(14) or any hazardous substance as defined by rule under chapter 70.105 RCW; any substance that, on the effective date of this section, is a hazardous substance under section 101(14) of the federal cleanup law, 42U.S.C., Sec. 9601(14); petroleum or petroleum products; and any substance or category of substances, including solid waste decomposition products, determined by the director by rule to present a threat to human health or the environment if released into the environment. The term hazardous substance does not include any of the following when contained in an underground storage tank from which there is not a release: crude oil or any fraction thereof or petroleum, if the tank is in compliance with all applicable federal, state, and local law.

Injection Well means a well that is used for the subsurface emplacement of fluids. (See **Well**.)

Jurisdiction means a political unit such as a city, town or county; incorporated for local self-government.

National Pollutant Discharge Elimination System (NPDES) means the national program for issuing, modifying, revoking and reissuing, terminating, monitoring, and enforcing permits, and imposing and enforcing pretreatment requirements, under sections 307, 402, 318, and 405 of the Federal Clean Water Act, for the discharge of pollutants to surface waters of the State from point sources. These permits are referred to as NPDES permits and, in Washington State, are administered by the Washington State Department of Ecology.

Notice of Intent (NOI) means the application for, or a request for coverage under this general permit pursuant to WAC 173-226-200.

Notice of Termination (NOT) means a request for termination of coverage under this general permit as specified by Special Condition S10 of this permit.

Operator means any party associated with a construction project that meets either of the following two criteria:

- The party has operational control over construction plans and specifications, including the ability to make modifications to those plans and specifications; or
- The party has day-to-day operational control of those activities at a project that are necessary to ensure compliance with a SWPPP for the site or other permit conditions (e.g., they are authorized to direct workers at a site to carry out activities required by the SWPPP or comply with other permit conditions).

Permittee means individual or entity that receives notice of coverage under this general permit.

pH means a liquid's measure of acidity or alkalinity. A pH of 7 is defined as neutral. Large variations above or below this value are considered harmful to most aquatic life.

pH Monitoring Period means the time period in which the pH of stormwater runoff from a site must be tested a minimum of once every seven days to determine if stormwater pH is between 6.5 and 8.5.

Point Source means any discernible, confined, and discrete conveyance, including but not limited to, any pipe, ditch, channel, tunnel, conduit, well, discrete fissure, and container from which pollutants are or may be discharged to surface waters of the State. This term does not include return flows from irrigated agriculture. (See the Fact Sheet for further explanation)

Pollutant means dredged spoil, solid waste, incinerator residue, filter backwash, sewage, garbage, domestic sewage sludge (biosolids), munitions, chemical wastes, biological materials, radioactive materials, heat, wrecked or discarded equipment, rock, sand, cellar dirt, and industrial, municipal, and agricultural waste. This term does not include sewage from vessels within the meaning of section 312 of the CWA, nor does it include dredged or fill material discharged in accordance with a permit issued under section 404 of the CWA.

Pollution means contamination or other alteration of the physical, chemical, or biological properties of waters of the State; including change in temperature, taste, color, turbidity, or odor of the waters; or such discharge of any liquid, gaseous, solid, radioactive or other substance into any waters of the State as will or is likely to create a nuisance or render such waters harmful, detrimental or injurious to the public health, safety or welfare; or to domestic, commercial, industrial, agricultural, recreational, or other legitimate beneficial uses; or to livestock, wild animals, birds, fish or other aquatic life.

Process Wastewater means any non-stormwater which, during manufacturing or processing, comes into direct contact with or results from the production or use of any raw material, intermediate product, finished product, byproduct, or waste product. If stormwater commingles with process wastewater, the commingled water is considered process wastewater.

Receiving Water means the waterbody at the point of discharge. If the discharge is to a storm sewer system, either surface or subsurface, the receiving water is the waterbody to which the storm system discharges. Systems designed primarily for other purposes such as for groundwater drainage, redirecting stream natural flows, or for conveyance of irrigation water/return flows that coincidentally convey stormwater are considered the receiving water.

Representative means a stormwater or wastewater sample which represents the flow and characteristics of the discharge. Representative samples may be a grab sample, a time-proportionate *composite sample*, or a flow proportionate sample. Ecology's Construction Stormwater Monitoring Manual provides guidance on representative sampling.

Responsible Corporate Officer for the purpose of signatory authority means: (i) a president, secretary, treasurer, or vice-president of the corporation in charge of a principal business function, or any other person who performs similar policy- or decision-making functions for the corporation, or (ii) the manager of one or more manufacturing, production, or operating facilities, provided, the manager is authorized to make management decisions which govern the operation of the regulated facility including having the explicit or implicit duty of making major capital investment recommendations, and initiating and directing other comprehensive measures to assure long term environmental compliance with environmental laws and regulations; the manager can ensure that the necessary systems are established or actions taken to gather complete and accurate information for permit application requirements; and where authority to sign documents has been assigned or delegated to the manager in accordance with corporate procedures (40 CFR 122.22).

Sanitary Sewer means a sewer which is designed to convey domestic wastewater.

Sediment means the fragmented material that originates from the weathering and erosion of rocks or unconsolidated deposits, and is transported by, suspended in, or deposited by water.

Sedimentation means the depositing or formation of sediment.

Sensitive Area means a waterbody, wetland, stream, aquifer recharge area, or channel migration zone.

SEPA (State Environmental Policy Act) means the Washington State Law, RCW 43.21C.020, intended to prevent or eliminate damage to the environment.

Significant Amount means an amount of a pollutant in a discharge that is amenable to available and reasonable methods of prevention or treatment; or an amount of a pollutant that has a reasonable potential to cause a violation of surface or groundwater quality or sediment management standards.

Significant Concrete Work means greater than 1000 cubic yards placed or poured concrete or recycled concrete used over the life of a project.

Significant Contributor of Pollutants means a facility determined by Ecology to be a contributor of a significant amount(s) of a pollutant(s) to waters of the State of Washington.

Site means the land or water area where any "facility or activity" is physically located or conducted.

Source Control BMPs means physical, structural or mechanical devices or facilities that are intended to prevent pollutants from entering stormwater. A few examples of source control BMPs are erosion control practices, maintenance of stormwater facilities, constructing roofs over storage and working areas, and directing wash water and similar discharges to the sanitary sewer or a dead end sump.

Stabilization means the application of appropriate BMPs to prevent the erosion of soils, such as, temporary and permanent seeding, vegetative covers, mulching and matting, plastic covering and sodding. See also the definition of Erosion and Sediment Control BMPs.

Storm Drain means any drain which drains directly into a *storm sewer system*, usually found along roadways or in parking lots.

Storm Sewer System means a means a conveyance, or system of conveyances (including roads with drainage systems, municipal streets, catch basins, curbs, gutters, ditches, manmade channels, or storm drains designed or used for collecting or conveying stormwater. This does not include systems which are part of a *combined sewer* or Publicly Owned Treatment Works (POTW), as defined at 40 CFR 122.2.

Stormwater means that portion of precipitation that does not naturally percolate into the ground or evaporate, but flows via overland flow, interflow, pipes, and other features of a stormwater drainage system into a defined surface waterbody, or a constructed infiltration facility.

Stormwater Management Manual (SWMM) or Manual means the technical Manual published by Ecology for use by local governments that contain descriptions of and design criteria for BMPs to prevent, control, or treat pollutants in stormwater.

Stormwater Pollution Prevention Plan (SWPPP) means a documented plan to implement measures to identify, prevent, and control the contamination of point source discharges of stormwater.

Surface Waters of the State includes lakes, rivers, ponds, streams, inland waters, salt waters, and all other surface waters and water courses within the jurisdiction of the state of Washington.

Temporary Stabilization means the exposed ground surface has been covered with appropriate materials to provide temporary stabilization of the surface from water or wind erosion. Materials include, but are not limited to, mulch, riprap, erosion control mats or blankets and temporary cover crops. Seeding alone is not considered stabilization. Temporary stabilization is not a substitute for the more permanent "final stabilization."

Total Maximum Daily Load (TMDL) means a calculation of the maximum amount of a pollutant that a waterbody can receive and still meet state water quality standards. Percentages of the total maximum daily load are allocated to the various pollutant sources. A TMDL is the sum of the allowable loads of a single pollutant from all contributing point and nonpoint sources. The TMDL calculations must include a "margin of safety" to ensure that the waterbody can be protected in case there are unforeseen events or unknown sources of the pollutant. The calculation must also account for seasonable variation in water quality.

Transfer of Coverage (TOC) means a request for transfer of coverage under this general permit as specified by Special Condition S2.A of this permit.

Treatment BMPs means BMPs that are intended to remove pollutants from stormwater. A few examples of treatment BMPs are detention ponds, oil/water separators, biofiltration, and constructed wetlands.

Transparency means a measurement of water clarity in centimeters (cm), using a 60 cm transparency tube. The transparency tube is used to estimate the relative clarity or transparency of water by noting the depth at which a black and white Secchi disc becomes visible when water is released from a value in the bottom of the tube. A transparency tube is sometimes referred to as a "turbidity tube."

Turbidity means the clarity of water expressed as nephelometric turbidity units (NTUs) and measured with a calibrated turbidimeter.

Uncontaminated means free from any contaminant. See definition of "contaminant" and WAC 173-340-200.

Upset means an exceptional incident in which there is unintentional and temporary noncompliance with technology-based permit effluent limitations because of factors beyond the reasonable control of the Permittee. An upset does not include noncompliance to the extent caused by operational error, improperly designed treatment facilities, inadequate treatment facilities, lack of preventive maintenance, or careless or improper operation.

Waste Load Allocation (WLA) means the portion of a receiving water's loading capacity that is allocated to one of its existing or future point sources of pollution. WLAs constitute a type of water quality based effluent limitation (40 CFR 130.2[h]).

Water-Only Based Shaft Drilling is a shaft drilling process that uses water only and no additives are involved in the drilling of shafts for construction of building, road, or bridge foundations.

Water Quality means the chemical, physical, and biological characteristics of water, usually with respect to its suitability for a particular purpose.

Waters of the State includes those waters as defined as "waters of the United States" in 40 CFR Subpart 122.2 within the geographic boundaries of Washington State and "waters of the State" as defined in Chapter 90.48 RCW, which include lakes, rivers, ponds, streams, inland waters, underground waters, salt

waters, and all other surface waters and water courses within the jurisdiction of the state of Washington.

Well means a bored, drilled or driven shaft, or dug hole whose depth is greater than the largest surface dimension. (See **Injection Well**.)

Wheel Wash Wastewater means any water used in, or resulting from the operation of, a tire bath or wheel wash (BMP C106: Wheel Wash), or other structure or practice that uses water to physically remove mud and debris from vehicles leaving a construction site and prevent track-out onto roads. When stormwater combines with wheel wash wastewater, the resulting water is considered wheel wash wastewater and must be managed according to Special Condition S9.D.9.

APPENDIX B – ACRONYMS

AKART	All Known, Available, and Reasonable Methods of Prevention, Control, and Treatment
BMP	Best Management Practice
CESCL	Certified Erosion and Sediment Control Lead
CFR	Code of Federal Regulations
CKD	Cement Kiln Dust
cm	Centimeters
CPD	Common Plan of Development
CTB	Cement-Treated Base
CWA	Clean Water Act
DMR	Discharge Monitoring Report
EPA	Environmental Protection Agency
ERTS	Environmental Report Tracking System
ESC	Erosion and Sediment Control
FR	Federal Register
LID	Low Impact Development
NOI	Notice of Intent
NOT	Notice of Termination
NPDES	National Pollutant Discharge Elimination System
NTU	Nephelometric Turbidity Unit
RCW	Revised Code of Washington
SEPA	State Environmental Policy Act
SWMM	Stormwater Management Manual
SWPPP	Stormwater Pollution Prevention Plan
TMDL	Total Maximum Daily Load
UIC	Underground Injection Control
USC	United States Code
USEPA	United States Environmental Protection Agency
WAC	Washington Administrative Code
WQ	Water Quality
WWHM	Western Washington Hydrology Model

E. 303(d) List Waterbodies / TMDL Waterbodies Information