



**JULIAN WEBER ARCHITECTS, LTD**  
 1257 S King St  
 Seattle, WA 98144  
 203.953.1305  
 www.jwaseattle.com

9458 REGISTERED ARCHITECT  
 JULIAN R. WEBER  
 STATE OF WASHINGTON

**COOMBES DEVELOPMENT**  
 4701 SW ADMIRAL WAY, SUITE 385  
 SEATTLE, WA 98116  
 P 206.420.7672

**Coombes Residence**  
 6221 83rd Pl SE  
 Mercer Island

MUP #	na	
BP #	2207-110	
Δ	Date	Description
	06.02.2022	Critical Area Submittal
	06.02.2022	BP Submittal
1	08.07.2023	PPR 1

**SITE PLAN**

Scale 1/8" = 1'-0"  
 Date 06/01/2023

**A0.1**

Project Number **JWA#611**

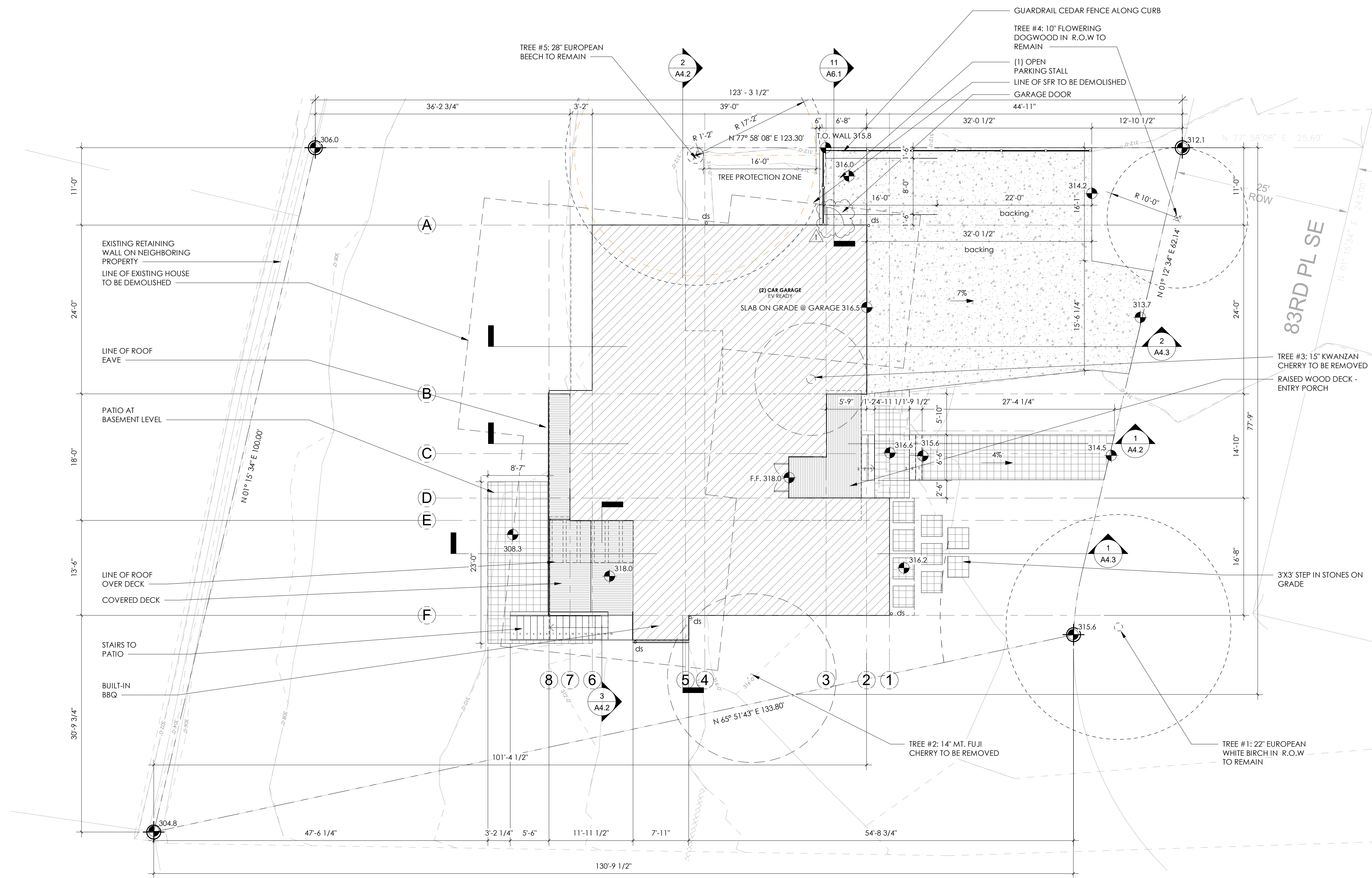

**1 Site Plan**  
 SCALE: 1/8" = 1'-0"

\*PLEASE REFERENCE 1/A1.3 FOR AVERAGE BUILDING CALCULATIONS.  
 \*\*PLEASE REFERENCE 1/A0.2 FOR BASEMENT FLOOR AREA CALCULATIONS.

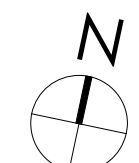

6/17/2023 2:57:30 PM



**JULIAN WEBER ARCHITECTS, LTD**  
 1257 S King St  
 Seattle, WA 98144  
 203.953.1305  
 www.jwaseattle.com

9458 REGISTERED ARCHITECT  
 JULIAN R. WEBER  
 STATE OF WASHINGTON

**COOMBS DEVELOPMENT**  
 4701 SW ADMIRAL WAY, SUITE 385  
 SEATTLE, WA 98116  
 P 206.420.7672

Coombes Residence  
 6221 83rd Pl SE  
 Mercer Island

MUP #	na
BP #	2207-110
Δ	Date Description
1	06.02.2022 BP Submittal
1	08.07.2023 PPR 1

**FAR  
DIAGRAMS**

Scale 1/8" = 1'-0"  
 Date 06/01/2023

**A0.2**

Project Number **JWA#611**

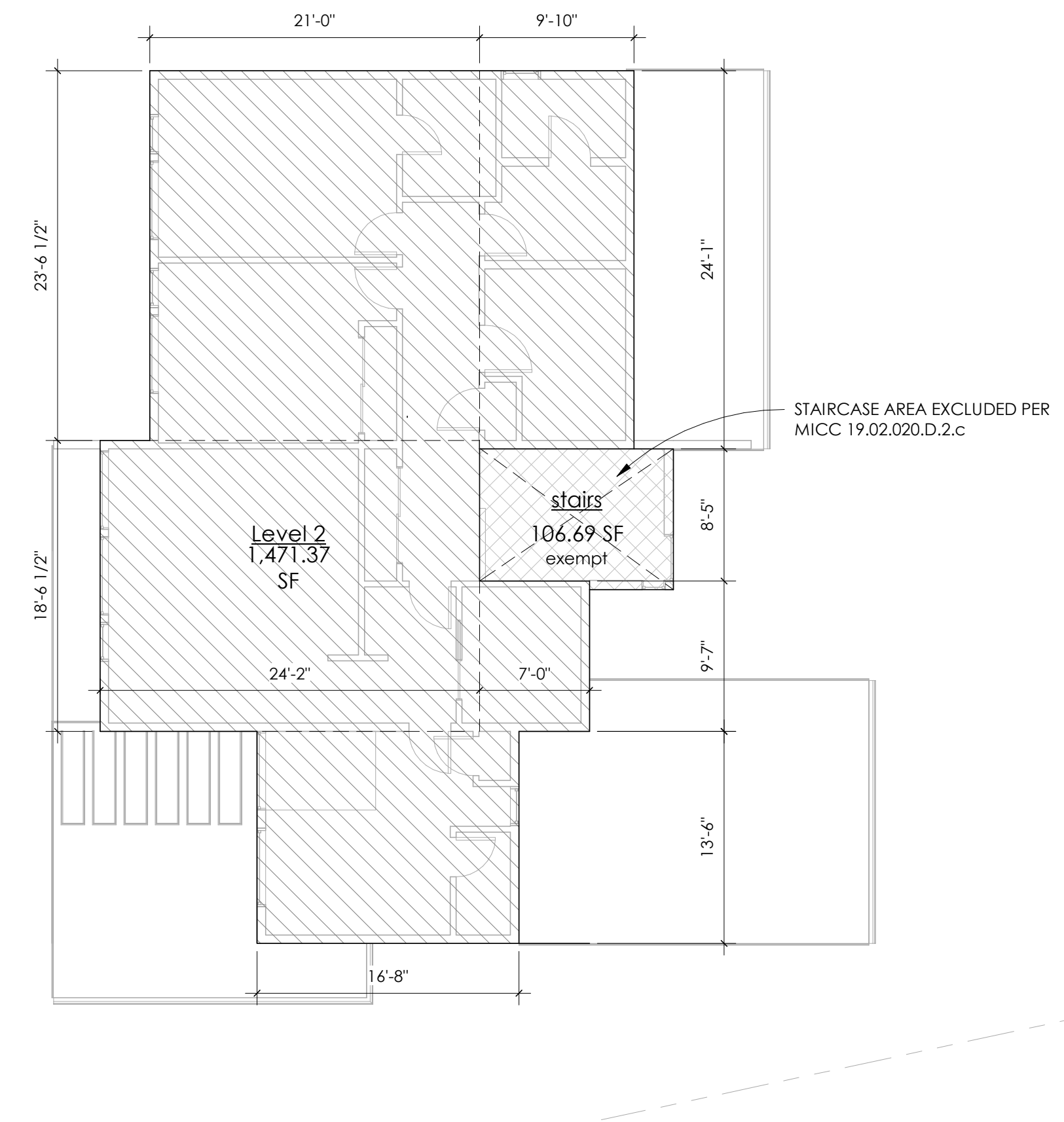

**3 Level 2**  
 SCALE: 1/8" = 1'-0"

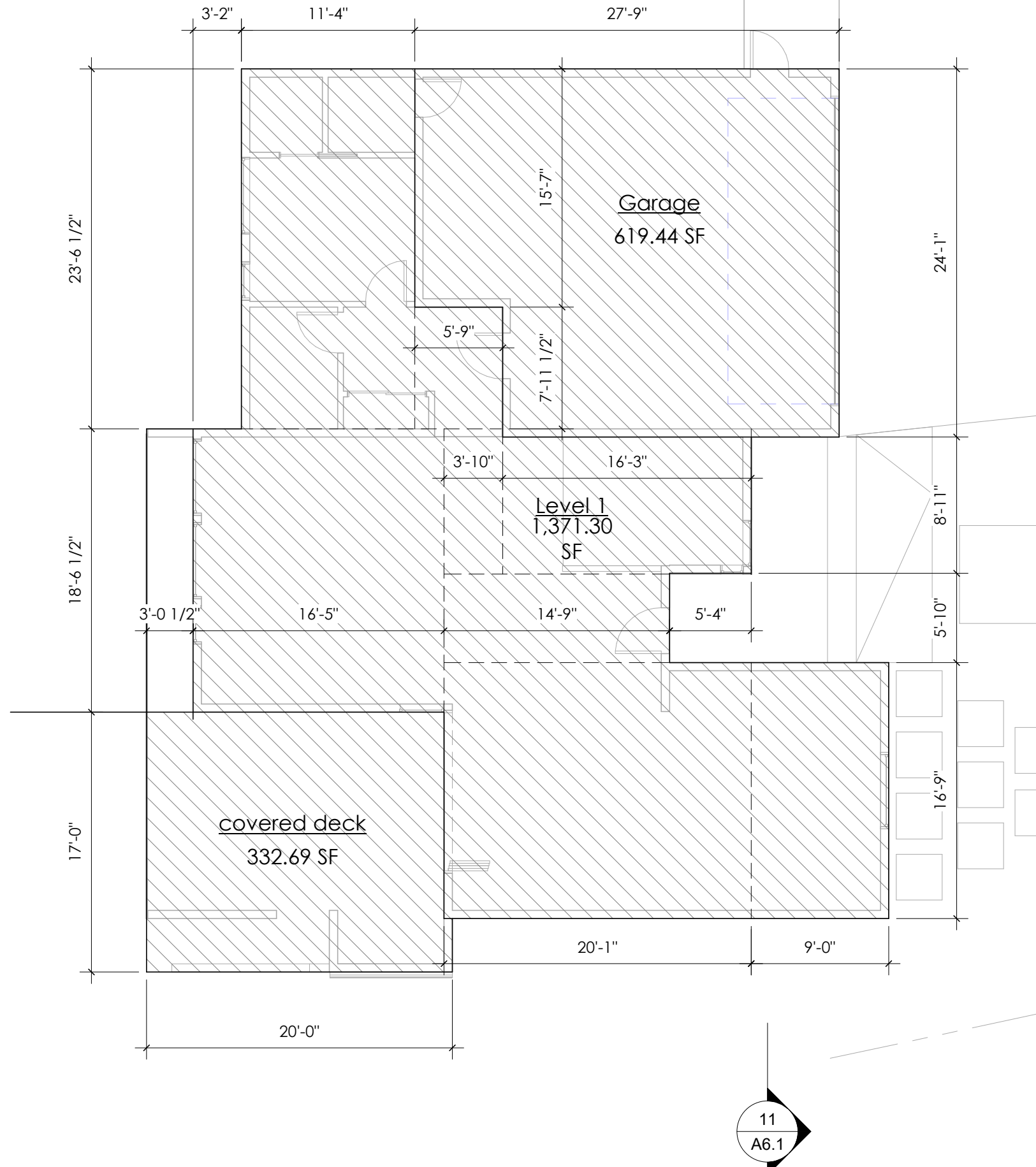

**2 Level 1**  
 SCALE: 1/8" = 1'-0"

**FAR CALCULATION**

LOT AREA	Base F.A.R.	ALLOWED	PROPOSED
10,284.00 SF	0.4	4,113.60 SF	4,109 SF

TOTAL EXISTING GFA = 4,477 SF REMOVED

**GFA TABLE**

FLOOR AREA LABEL	GFA	CHARGEABLE FLOOR AREA	EXEMPT PER
Basement	314 SF	314.36 SF	
Basement	808 SF	0.00 SF	MICC Title 19 - Appendix B
covered deck	333 SF	332.69 SF	
Garage	619 SF	619.44 SF	
Level 1	1,371 SF	1,371.30 SF	
Level 2	1,471 SF	1,471.37 SF	
stairs	107 SF	0.00 SF	MICC 19.02.020.D.2.c
<b>TOTAL</b>	<b>5,024 SF</b>	<b>4,109.15 SF</b>	

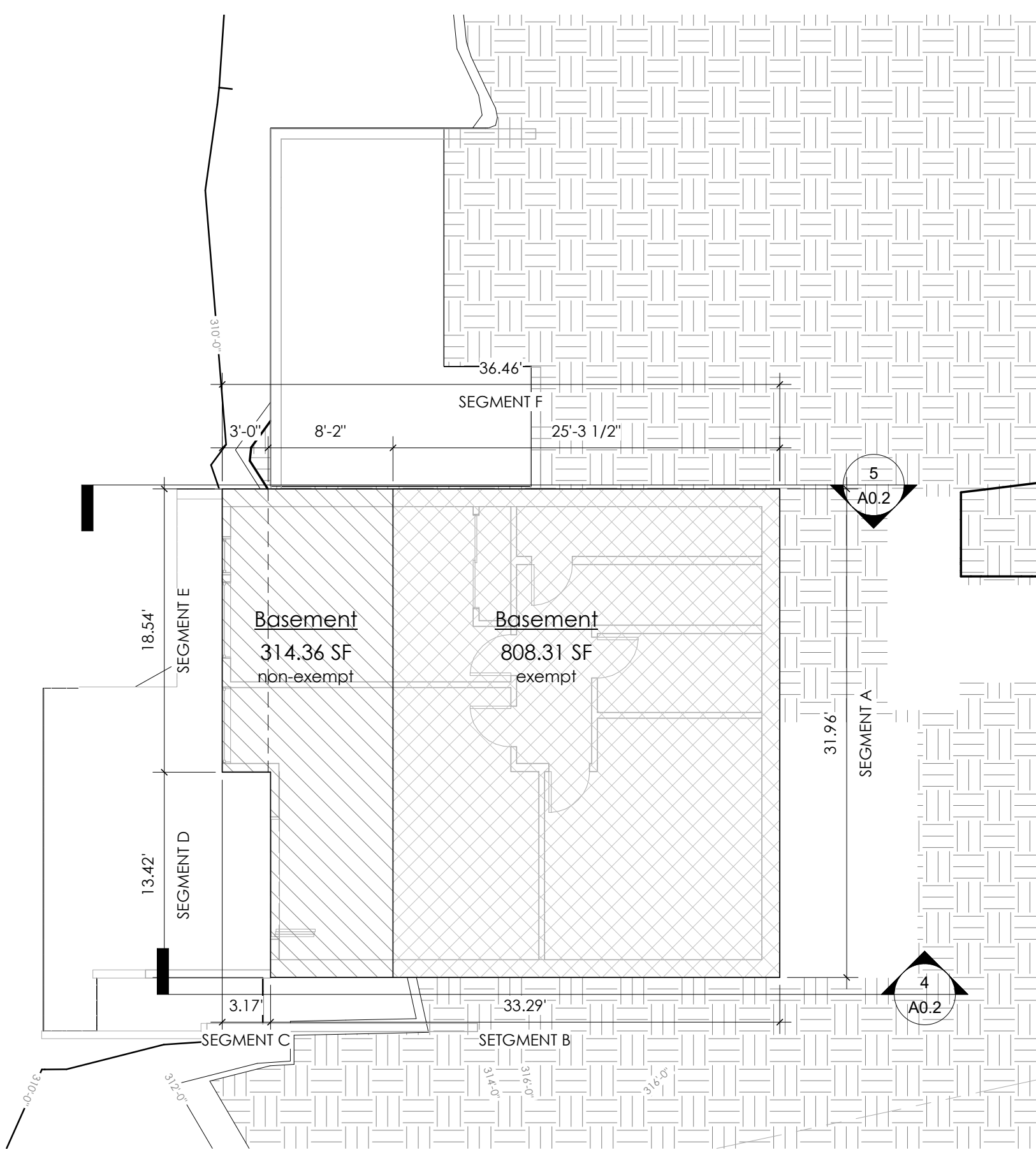

**1 Basement**  
 SCALE: 1/8" = 1'-0"

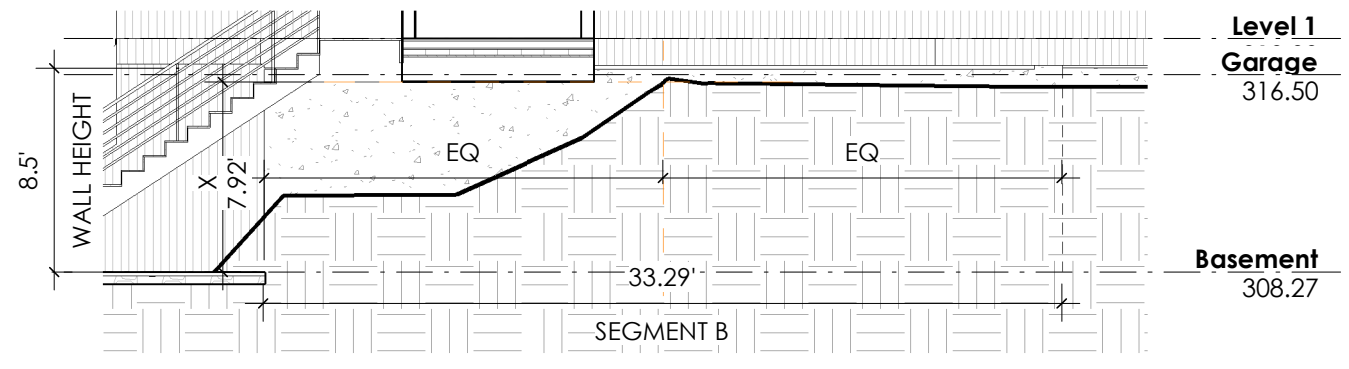

**MICC TITLE 19 - UNIFIED LAND DEVELOPMENT APPENDICES  
 APPENDIX B - BASEMENT FLOOR AREA CALCULATION**

**STEP 2 - WALL SEGMENT COVERAGE**

A = 100%  
 B = 7.92/8.5 x 100 = 93.18 %  
 C = 0 %  
 D = 0 %  
 E = 0 %  
 F = 8.4/8.5 x 100 = 98.82 %

**STEP 3 - (WALL LENGTH x %COVERAGE)**

A = 31.96 x 100% = 3,196  
 B = 33.29 x 93.18 % = 3,101.96  
 C = 3.17 x 0 % = 0  
 D = 13.42 x 0 % = 0  
 E = 18.54 x 0 % = 0  
 F = 36.46 x 98.82 % = 3,602.98

**TOTAL WALL LENGTH = 136.84'**  
**TOTAL SUM = 9,900.94/100 = 99.01**

**STEP 4**

99.01/136.84 = 0.72 x 100 = **72% AREA EXCLUDED**

**BASEMENT TOTAL GROSS FLOOR AREA = 1,122.66 SF**  
**1,122.66 x 0.72 = 808.31 SF AREA EXCLUDED**

**4 SEGMENT B**  
 SCALE: 1/8" = 1'-0"

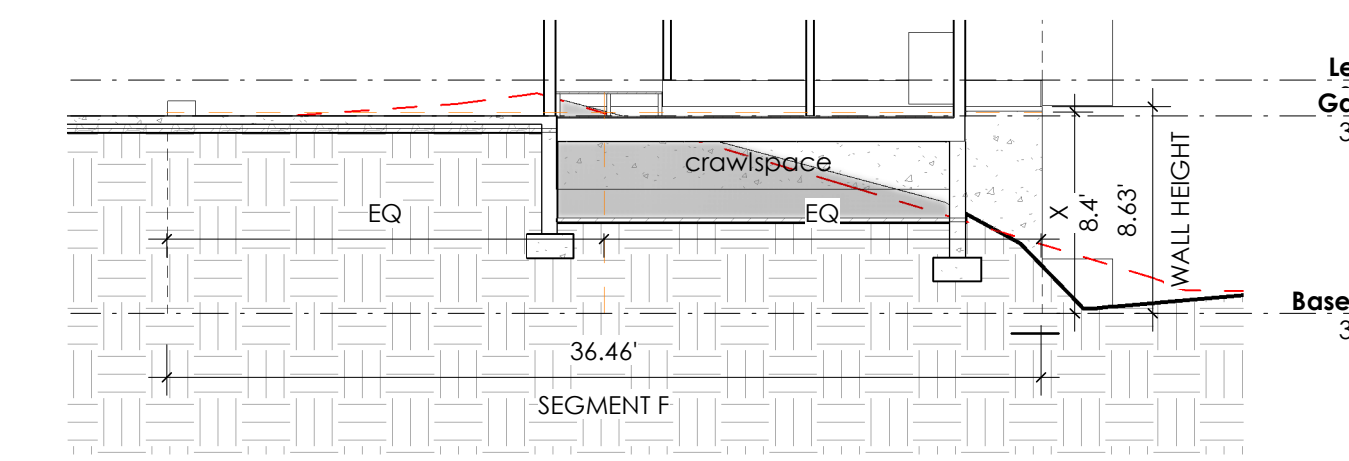

**5 SEGMENT F**  
 SCALE: 1/8" = 1'-0"

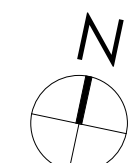



JULIAN WEBER ARCHITECTS, LTD

1257 S King St  
Seattle, WA 98144  
203.953.1305

www.jwseattle.com

9458 REGISTERED ARCHITECT  
JULIAN R. WEBER  
STATE OF WASHINGTON

COOMBS DEVELOPMENT

4701 SW ADMIRAL WAY, SUITE 385  
SEATTLE, WA 98116  
P 206.420.7672

Coombes Residence

6221 83rd Pl SE  
Mercer Island

MUP # na

BP # 2207-110

Δ	Date	Description
1	06.02.2022	BP Submittal
1	08.07.2023	PPR 1

### FLOOR PLANS

Scale 1/4" = 1'-0"

Date 06/01/2023

# A2.1

Project Number JWA#611

6/17/2023 2:57:32 PM

### CRAWLSPACE VENTILATION

WHOLE HOUSE VENTILATION TO CONFORM TO IRC R408

CRAWLSPACE 1 AREA: 285.5 SF  
 VENTILATION REQUIRED: (285.5 SF / 300) X 144 SI/SF = 137.04 SI  
 16" X 18" CRAWLSPACE VENT: 128 SI EA, -25% REDUCTION = 96 SI each  
 TOTAL VENTILATION REQUIRED: 137.04 SI / 96 SI = 1.4 VENTS

PROVIDE: (2) 16" X 8" CRAWLSPACE VENTS

CRAWLSPACE 2 AREA: 128.5 SF  
 VENTILATION REQUIRED: (128.5 SF / 300) X 144 SI/SF = 61.68 SI

16" X 18" CRAWLSPACE VENT: 128 SI EA, -25% REDUCTION = 96 SI each  
 TOTAL VENTILATION REQUIRED: 61.68 SI / 96 SI = 0.6 VENTS

PROVIDE: (2) 16" X 8" CRAWLSPACE VENTS

REQUIRED OPENINGS SHALL BE EVENLY SPACED TO PROVIDE CROSS VENTILATION OF THE SPACE EXCEPT ONE SIDE OF THE BUILDING SHALL BE PERMITTED TO HAVE NO VENTILATION OPENINGS.

### FLOOR PLAN NOTES:

- \* ALL INTERIOR WALLS TO BE 2x4 @ 24" O.C. (U.N.O.)
- \* ALL EXTERIOR WALLS 2x6 PER STRUCTURAL
- \* HEADERS PER STRUCTURAL
- \* WINDOW SIZES ARE NOMINAL ROUGH OPENING, WIDTH AND HEIGHT.
- \* PROVIDE FIREBLOCKING AT ALL PLUMBING OPENINGS.
- \* PROVIDE SOLID BLOCKING OVER SUPPORTS.
- \* SEISMIC ANCHORAGE AND STRAPPING OF WATER HEATERS SHALL BE IN ACCORDANCE WITH SECTION 507.2 OF THE UNIFORM PLUMBING CODE
- \* PROVIDE OUTDOOR COMBUSTION AIR FOR FURNACE AND WATER HEATER PER IRC G2407.6.

### CARBON MONOXIDE DETECTORS

#### IRC R315.1 CARBON MONOXIDE ALARMS.

FOR NEW CONSTRUCTION, AN APPROVED CARBON MONOXIDE ALARM SHALL BE INSTALLED OUTSIDE OF EACH SEPARATE SLEEPING AREA IN THE IMMEDIATE VICINITY OF THE BEDROOMS IN DWELLING UNITS AND ON EACH LEVEL OF THE DWELLING AND IN ACCORDANCE WITH THE MANUFACTURERS DIRECTIONS.

THE CO DETECTORS MAY BE CONNECTED TO THE FIRE ALARM SYSTEM.

### SMOKE DETECTORS

#### IRC R314.3 SMOKE ALARMS

SMOKE ALARMS SHALL BE INSTALLED IN THE FOLLOWING LOCATIONS:  
 1. IN EACH SLEEPING ROOM.  
 2. OUTSIDE EACH SEPARATE SLEEPING AREA IN THE IMMEDIATE VICINITY OF THE BEDROOMS.  
 3. ON EACH ADDITIONAL STORY OF THE DWELLING, INCLUDING BASEMENTS, BUT NOT INCLUDING CRAWLSPACES AND UNINHABITABLE ATTICS, IN DWELLINGS OR DWELLING UNITS WITH SPLIT LEVELS AND WITHOUT AN INTERVENING DOOR BETWEEN ADJACENT LEVELS, A SMOKE ALARM INSTALLED ON THE UPPER FLOOR SHALL SUFFICE FOR THE ADJACENT LOWER LEVEL PROVIDED THAT THE LOWER LEVEL IS LESS THAN ONE FULL STORY BELOW THE UPPER LEVEL.  
 4. NOT LESS THAN 3 FEET HORIZONTALLY FROM THE DOOR OR OPENING OF A BATHROOM THAT CONTAINS A BATHTUB OR SHOWER UNLESS THIS WOULD PREVENT PLACEMENT OF A SMOKE ALARM REQUIRED BY THIS SECTION.

SMOKE DETECTORS TO BE HARDWIRED, INTERCONNECTED, WITH BATTERY BACKUP PER IRC R314.4.

INSTALL A NFPA 72 "CH 29" HOUSEHOLD FIRE ALARM PER COMI AND NFPA STANDARDS.

A FIRE ALARM SYSTEM MAY TAKE THE PLACE OF A LINE VOLTAGE SMOKE DETECTOR SYSTEM PER IBC.

### VENTILATION SCHEDULE

WHOLE HOUSE VENTILATION TO CONFORM TO IRC SECTION M1505.4

CFM	MECHANICAL VENTILATING SYSTEMS IN BATHROOMS, LAUNDRY ROOMS AND SIMILAR ROOMS SHOULD EXHAUST DIRECTLY TO THE OUTSIDE. THE POINT OF DISCHARGE OF EXHAUST AIR SHALL BE AT LEAST THREE FEET FROM ANY OPENING INTO THE BUILDING PER IRC M1504.3
100 CFM ON SWITCH	
50 CFM ON SWITCH	
90 CFM CONTINUOUSLY OPERATING WHOLE HOUSE FAN, SIZED PER TABLE IRC M1505.4.3(1)	

THE AIR REMOVED BY EVERY MECHANICAL EXHAUST SYSTEM SHALL BE DISCHARGED TO THE OUTDOORS IN ACCORDANCE WITH SECTION M1504.3.

LOCAL EXHAUST SYSTEMS SHALL BE DESIGNED TO HAVE THE CAPACITY TO EXHAUST THE MINIMUM AIRFLOW RATE DETERMINED IN ACCORDANCE WITH TABLE M1505.4.4.

\*FOR REFERENCE ONLY

Marketable 608 SF Garage (Proposed)  
262 SF Covered deck

Basement 1,123 SF

Level 1 1,383 SF

Level 2 1,546 SF

TOTAL: 4,051 SF

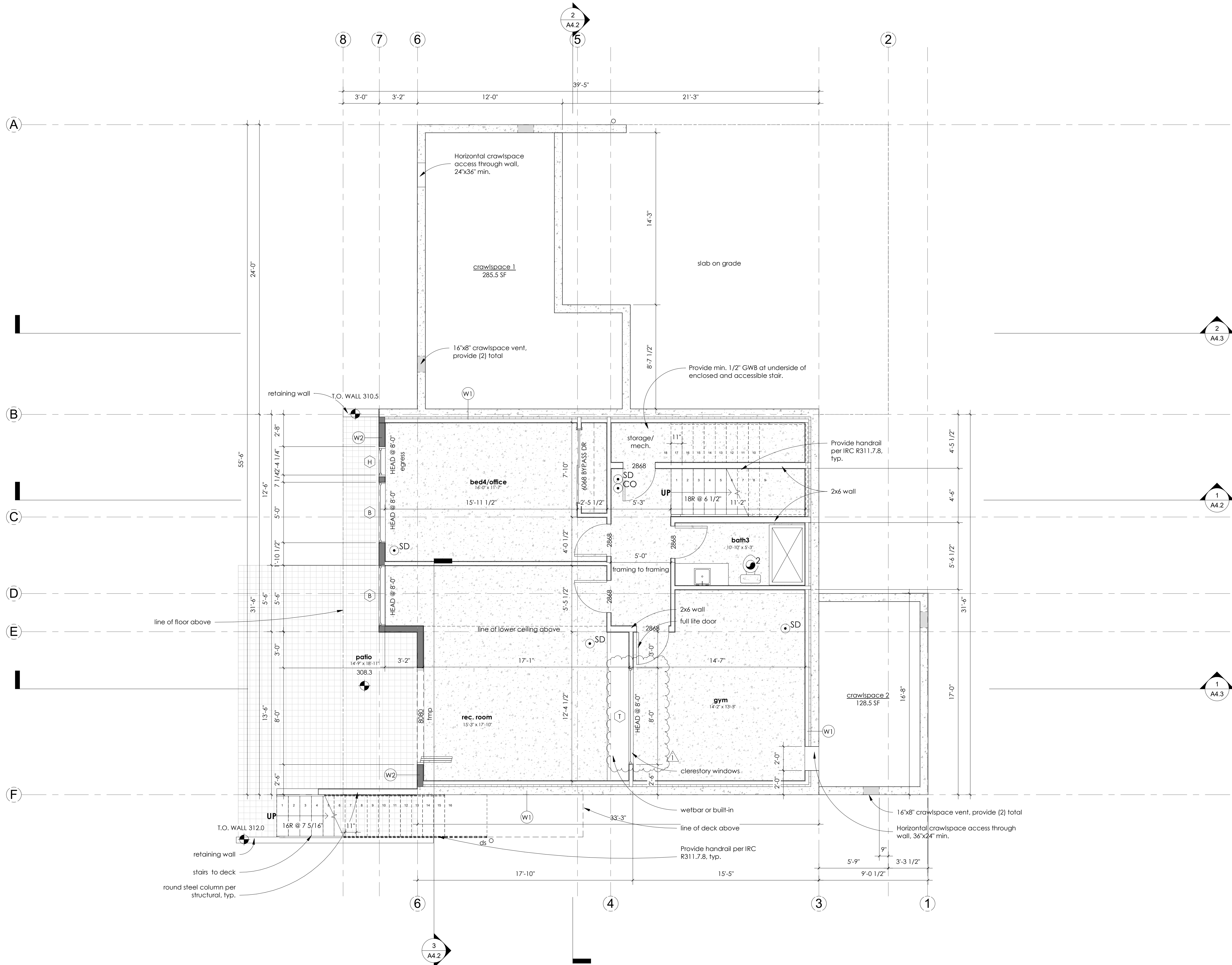

## 1 Basement

SCALE: 1/4" = 1'-0"

\* NOT CEILING HEIGHT GREATER THAN 10 FT. PLEASE REFERENCE SECTIONS A4.2-3.

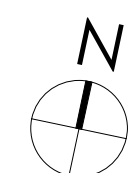

**GARAGE NOTES:**

\* THE GARAGE SHALL BE SEPARATED FROM THE RESIDENCE AND ITS ATTIC AREA BY NOT LESS THAN 1/2" GWB APPLIED TO THE GARAGE SIDE. GARAGES BENEATH HABITABLE ROOMS SHALL BE SEPARATED FROM ALL HABITABLE ROOMS ABOVE BY NOT LESS THAN 5/8" TYPE X GYPSUM BOARD OR EQUIVALENT. WHERE THE SEPARATION IS A FLOOR-CEILING ASSEMBLY, THE STRUCTURE SUPPORTING THE SEPARATION SHALL ALSO BE PROTECTED BY NOT LESS THAN 1/2-INCH GYPSUM BOARD OR EQUIVALENT. SRC R302.6

\* ...OPENINGS BETWEEN THE GARAGE AND RESIDENCE SHALL BE EQUIPPED WITH SOLID WOOD DOORS NOT LESS THAN 1 3/8" IN THICKNESS. SOLID OR HONEYCOMB CORE STEEL DOORS NOT LESS THAN 1 3/8" THICK, OR 20-MINUTE FIRE-RATED DOORS. SRC 302.5.1

\* DUCTS IN THE GARAGE AND DUCTS PENETRATING THE WALLS OR CEILINGS SEPARATING THE DWELLING FROM THE GARAGE SHALL BE CONSTRUCTED OF A MINIMUM NO. 26 GAGE SHEET STEEL OR OTHER APPROVED MATERIALS AND SHALL HAVE NO OPENINGS INTO THE GARAGE. IRC R302.5.2

\* SEISMIC ANCHORAGE AND STRAPPING OF WATER HEATERS SHALL BE IN ACCORDANCE WITH SECTION 507.2 OF THE UNIFORM PLUMBING CODE.

**FLOOR PLAN NOTES:**

- \* ALL INTERIOR WALLS TO BE 2x4 @ 24" O.C. (U.N.O.)
- \* ALL EXTERIOR WALLS 2x6 PER STRUCTURAL
- \* HEADERS PER STRUCTURAL
- \* WINDOW SIZES ARE NOMINAL ROUGH OPENING, WIDTH AND HEIGHT.
- \* PROVIDE FIREBLOCKING AT ALL PLUMBING OPENINGS.
- \* PROVIDE SOLID BLOCKING OVER SUPPORTS.
- \* SEISMIC ANCHORAGE AND STRAPPING OF WATER HEATERS SHALL BE IN ACCORDANCE WITH SECTION 507.2 OF THE UNIFORM PLUMBING CODE
- \* PROVIDE OUTDOOR COMBUSTION AIR FOR FURNACE AND WATER HEATER PER IRC G2407.6.

**CARBON MONOXIDE DETECTORS**

**IRC R315.1 CARBON MONOXIDE ALARMS.**

FOR NEW CONSTRUCTION, AN APPROVED CARBON MONOXIDE ALARM SHALL BE INSTALLED OUTSIDE OF EACH SEPARATE SLEEPING AREA IN THE IMMEDIATE VICINITY OF THE BEDROOMS IN DWELLING UNITS AND ON EACH LEVEL OF THE DWELLING AND IN ACCORDANCE WITH THE MANUFACTURERS DIRECTIONS.

THE CO DETECTORS MAY BE CONNECTED TO THE FIRE ALARM SYSTEM.

**SMOKE DETECTORS**

**IRC R314.3 SMOKE ALARMS**

- SMOKE ALARMS SHALL BE INSTALLED IN THE FOLLOWING LOCATIONS:
1. IN EACH SLEEPING ROOM
  2. OUTSIDE EACH SEPARATE SLEEPING AREA IN THE IMMEDIATE VICINITY OF THE BEDROOMS.
  3. ON EACH ADDITIONAL STORY OF THE DWELLING, INCLUDING BASEMENTS, BUT NOT INCLUDING CRAWLSPACES AND UNINHABITABLE ATTICS, IN DWELLINGS OR DWELLING UNITS WITH SPLIT LEVELS AND WITHOUT AN INTERVENING DOOR BETWEEN ADJACENT LEVELS. A SMOKE ALARM INSTALLED ON THE UPPER FLOOR SHALL SUFFICE FOR THE ADJACENT LOWER LEVEL PROVIDED THAT THE LOWER LEVEL IS LESS THAN ONE FULL STORY BELOW THE UPPER LEVEL.
  4. NOT LESS THAN 3 FEET HORIZONTALLY FROM THE DOOR OR OPENING OF A BATHROOM THAT CONTAINS A BATHUB OR SHOWER UNLESS THIS WOULD PREVENT PLACEMENT OF A SMOKE ALARM REQUIRED BY THIS SECTION.

SMOKE DETECTORS TO BE HARDWIRED, INTERCONNECTED, WITH BATTERY BACKUP PER IRC R314.4.

INSTALL A NFPA 72 "CH 29" HOUSEHOLD FIRE ALARM PER COMI AND NFPA STANDARDS.

A FIRE ALARM SYSTEM MAY TAKE THE PLACE OF A LINE VOLTAGE SMOKE DETECTOR SYSTEM PER IRC.

**HEAT DETECTORS**

A HEAT DETECTOR OR HEAT ALARM RATED FOR THE AMBIENT OUTDOOR TEMPERATURES AND HUMIDITY SHALL BE INSTALLED IN NEW GARAGES THAT ARE ATTACHED TO OR LOCATED UNDER NEW AND EXISTING DWELLINGS. HEAT DETECTORS AND HEAT ALARMS SHALL BE INSTALLED IN A CENTRAL LOCATION AND IN ACCORDANCE WITH THE MANUFACTURERS INSTRUCTIONS.

HEAT DETECTORS AND HEAT ALARMS SHALL BE CONNECTED TO AN ALARM OR A SMOKE ALARM THAT IS INSTALLED IN THE DWELLING. ALARMS AND SMOKE ALARMS THAT ARE INSTALLED FOR THIS PURPOSE SHALL BE LOCATED IN A HALLWAY, ROOM, OR OTHER LOCATION THAT WILL PROVIDE OCCUPANT NOTIFICATION.

THE REQUIRED HEAT DETECTOR IN THE GARAGE MAY BE CONNECTED TO THE FIRE ALARM SYSTEM.

**VENTILATION SCHEDULE**

WHOLE HOUSE VENTILATION TO CONFORM TO IRC SECTION M1505.4

- |  |   |
|--|---|
| <ul style="list-style-type: none"> <li>1 100 CFM ON SWITCH</li> <li>2 50 CFM ON SWITCH</li> <li>3 90 CFM CONTINUOUSLY OPERATING WHOLE HOUSE FAN, SIZED PER TABLE IRC M1505.4.3(1)</li> </ul> | <p>MECHANICAL VENTILATING SYSTEMS IN BATHROOMS, LAUNDRY ROOMS AND SIMILAR ROOMS SHOULD EXHAUST DIRECTLY TO THE OUTSIDE. THE POINT OF DISCHARGE OF EXHAUST AIR SHALL BE AT LEAST THREE FEET FROM ANY OPENING INTO THE BUILDING PER IRC M1504.3</p> |
|--|---|

THE AIR REMOVED BY EVERY MECHANICAL EXHAUST SYSTEM SHALL BE DISCHARGED TO THE OUTDOORS IN ACCORDANCE WITH SECTION M1504.3.

LOCAL EXHAUST SYSTEMS SHALL BE DESIGNED TO HAVE THE CAPACITY TO EXHAUST THE MINIMUM AIRFLOW RATE DETERMINED IN ACCORDANCE WITH TABLE M1505.4.4.

**ROOF DECK VENTILATION**

UNVENTED ASSEMBLY TO COMPLY WITH IRC R806.5

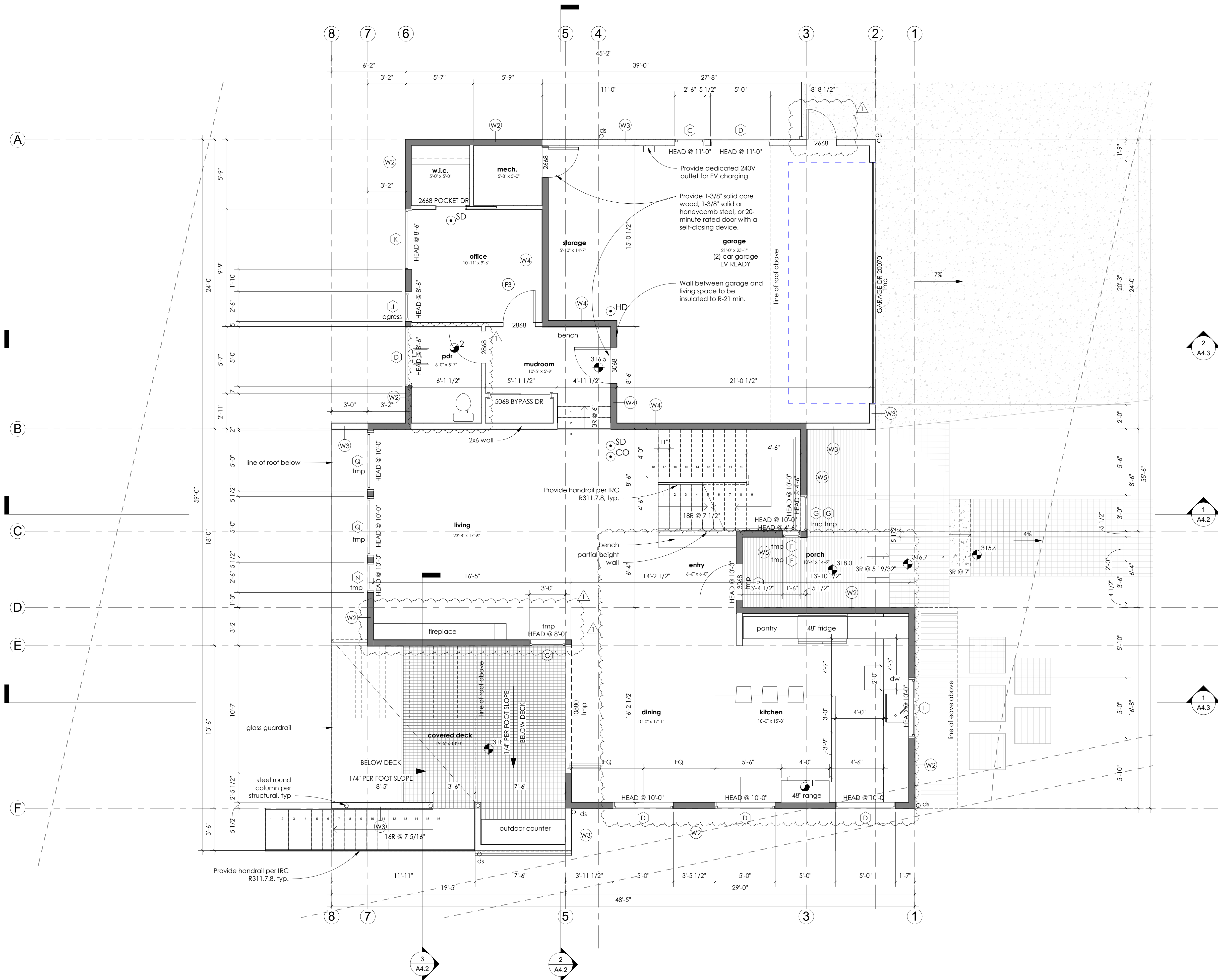

**1 Main Level**

SCALE: 1/4" = 1'-0"

\* NOT CEILING HEIGHT GREATER THAN 10 FT. PLEASE REFERENCE SECTIONS A4.2-3.



**JULIAN WEBER ARCHITECTS, LTD**

1257 S King St  
Seattle, WA 98144  
206.953.1305

www.jwseattle.com

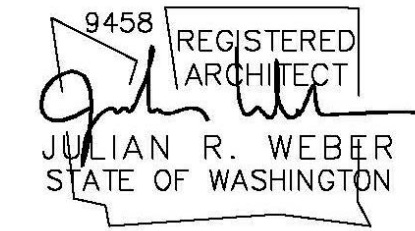

**COOMBS DEVELOPMENT**

4701 SW ADMIRAL WAY, SUITE 385  
SEATTLE, WA 98116  
P 206.420.7672

Coombes Residence

6221 83rd Pl SE  
Mercer Island

MUP # **na**

BP # **2207-110**

Δ	Date	Description
1	06.02.2022	BP Submittal
1	08.07.2023	PPR 1

**FLOOR PLANS**

Scale **1/4" = 1'-0"**  
Date **06/01/2023**

**A2.2**

Project Number **JWA#611**



**JULIAN WEBER ARCHITECTS, LTD**  
 1257 S King St  
 Seattle, WA 98144  
 206.953.1305  
 www.jwseattle.com

9458 REGISTERED ARCHITECT  
 JULIAN R. WEBER  
 STATE OF WASHINGTON

**COOMBES DEVELOPMENT**  
 4701 SW ADMIRAL WAY, SUITE 385  
 SEATTLE, WA 98116  
 P 206.420.7672

**Coombes Residence**  
 6221 83rd Pl SE  
 Mercer Island

MUP #	na
BP #	2207-110
Δ	Date Description
1	06.02.2022 BP Submittal
1	08.07.2023 PPR 1

**FLOOR PLANS**

Scale 1/4" = 1'-0"  
 Date 06/01/2023

**A2.3**

Project Number **JWA#611**

6/17/2023 2:57:33 PM

**FLOOR PLAN NOTES:**

- \* ALL INTERIOR WALLS TO BE 2x4 @ 24" O.C. (I.N.O.)
- \* ALL EXTERIOR WALLS 2x6 PER STRUCTURAL
- \* HEADERS PER STRUCTURAL
- \* WINDOW SIZES ARE NOMINAL ROUGH OPENING, WIDTH AND HEIGHT.
- \* PROVIDE FIREBLOCKING AT ALL PLUMBING OPENINGS.
- \* PROVIDE SOLID BLOCKING OVER SUPPORTS.
- \* SEISMIC ANCHORAGE AND STRAPPING OF WATER HEATERS SHALL BE IN ACCORDANCE WITH SECTION 507.2 OF THE UNIFORM PLUMBING CODE
- \* PROVIDE OUTDOOR COMBUSTION AIR FOR FURNACE AND WATER HEATER PER IRC G2407.6.

**SMOKE DETECTORS**

**IRC R314.3 SMOKE ALARMS**

SMOKE ALARMS SHALL BE INSTALLED IN THE FOLLOWING LOCATIONS:  
 1. IN EACH SLEEPING ROOM  
 2. OUTSIDE EACH SEPARATE SLEEPING AREA IN THE IMMEDIATE VICINITY OF THE BEDROOMS.  
 3. ON EACH ADDITIONAL STORY OF THE DWELLING, INCLUDING BASEMENTS, BUT NOT INCLUDING CRAWLSPACES AND UNINHABITABLE ATTICS, IN DWELLINGS OR DWELLING UNITS WITH SPLIT LEVELS AND WITHOUT AN INTERVENING DOOR BETWEEN ADJACENT LEVELS. A SMOKE ALARM INSTALLED ON THE UPPER FLOOR SHALL SUFFICE FOR THE ADJACENT LOWER LEVEL PROVIDED THAT THE LOWER LEVEL IS LESS THAN ONE FULL STORY BELOW THE UPPER LEVEL.  
 4. NOT LESS THAN 3 FEET HORIZONTALLY FROM THE DOOR OR OPENING OF A BATHROOM THAT CONTAINS A BATHTUB OR SHOWER UNLESS THIS WOULD PREVENT PLACEMENT OF A SMOKE ALARM REQUIRED BY THIS SECTION.

SMOKE DETECTORS TO BE HARDWIRED, INTERCONNECTED, WITH BATTERY BACKUP PER IRC R314.4.

INSTALL A NFPA 72 "CH 29" HOUSEHOLD FIRE ALARM PER COMI AND NFPA STANDARDS.

A FIRE ALARM SYSTEM MAY TAKE THE PLACE OF A LINE VOLTAGE SMOKE DETECTOR SYSTEM PER IBC.

**CARBON MONOXIDE DETECTORS**

**IRC R315.1 CARBON MONOXIDE ALARMS.**

FOR NEW CONSTRUCTION, AN APPROVED CARBON MONOXIDE ALARM SHALL BE INSTALLED OUTSIDE OF EACH SEPARATE SLEEPING AREA IN THE IMMEDIATE VICINITY OF THE BEDROOMS IN DWELLING UNITS AND ON EACH LEVEL OF THE DWELLING AND IN ACCORDANCE WITH THE MANUFACTURERS DIRECTIONS.

THE CO DETECTORS MAY BE CONNECTED TO THE FIRE ALARM SYSTEM.

**VENTILATION SCHEDULE**

**WHOLE HOUSE VENTILATION TO CONFORM TO IRC SECTION M1505.4**

1	100 CFM ON SWITCH	MECHANICAL VENTILATING SYSTEMS IN BATHROOMS, LAUNDRY ROOMS AND SIMILAR ROOMS SHOULD EXHAUST DIRECTLY TO THE OUTSIDE. THE POINT OF DISCHARGE OF EXHAUST AIR SHALL BE AT LEAST THREE FEET FROM ANY OPENING INTO THE BUILDING PER IRC M1504.3
2	50 CFM ON SWITCH	
3	90 CFM CONTINUOUSLY OPERATING WHOLE HOUSE FAN, SIZED PER TABLE IRC M1505.4.3(1)	

THE AIR REMOVED BY EVERY MECHANICAL EXHAUST SYSTEM SHALL BE DISCHARGED TO THE OUTDOORS IN ACCORDANCE WITH SECTION M1504.3.

LOCAL EXHAUST SYSTEMS SHALL BE DESIGNED TO HAVE THE CAPACITY TO EXHAUST THE MINIMUM AIRFLOW RATE DETERMINED IN ACCORDANCE WITH TABLE M1505.4.4.

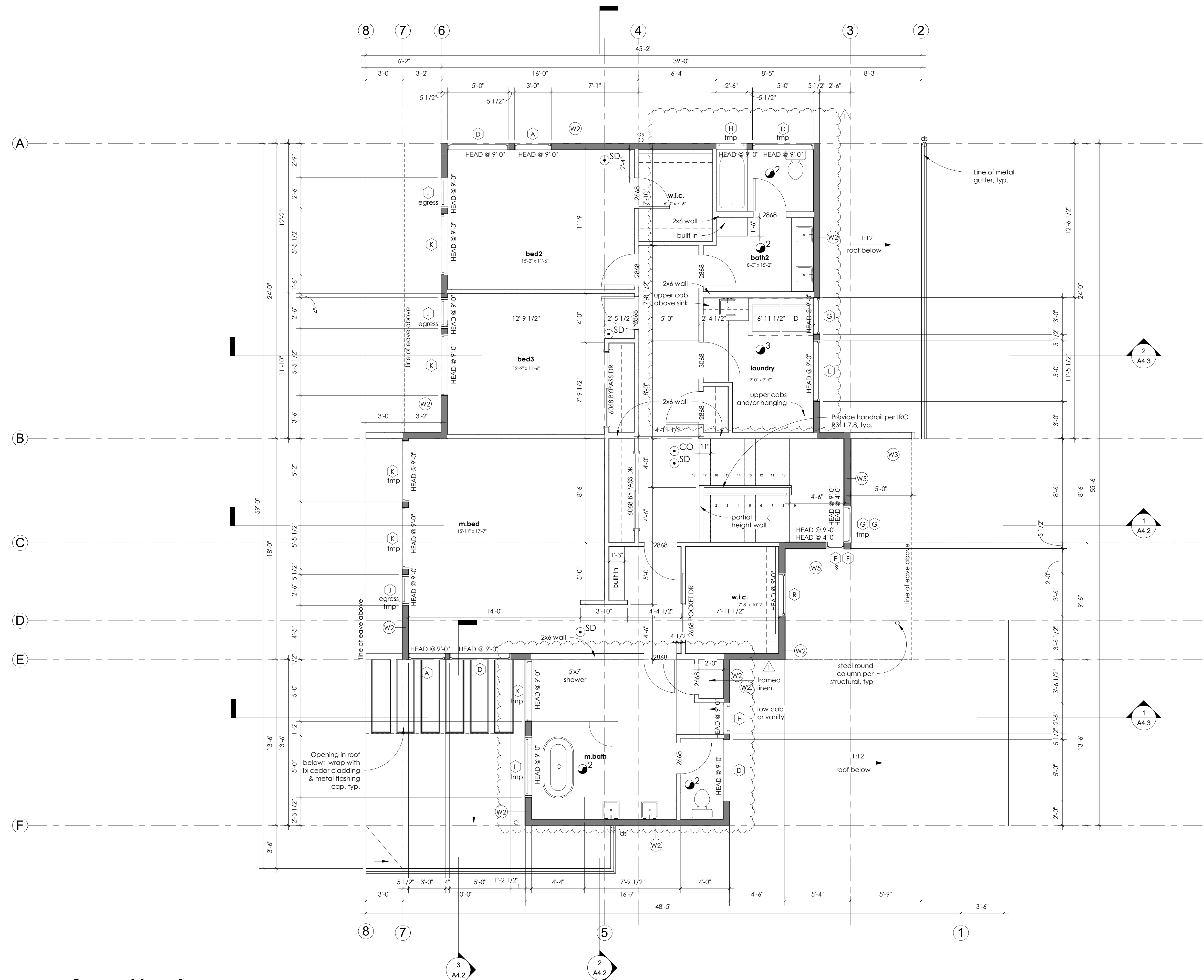

**1 Second Level**  
 SCALE: 1/4" = 1'-0"  
 \* NOT CEILING HEIGHT GREATER THAN 10 FT. PLEASE REFERENCE SECTIONS A4.2-3.

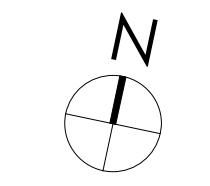



**JULIAN WEBER ARCHITECTS, LTD**  
 1257 S King St  
 Seattle, WA 98144  
 203.953.1305  
 www.jwaseattle.com

9458 REGISTERED ARCHITECT  
  
 JULIAN R. WEBER  
 STATE OF WASHINGTON

**COOMBES DEVELOPMENT**  
 4701 SW ADMIRAL WAY, SUITE 385  
 SEATTLE, WA 98116  
 P 206.420.7672

**Coombes Residence**  
 6221 83rd Pl SE  
 Mercer Island

MUP #	na	
BP #	2207-110	
<b>Δ</b>	<b>Date</b>	<b>Description</b>
1	06.02.2022	BP Submittal
	08.07.2023	PPR 1

**FLOOR PLANS**

Scale 1/4" = 1'-0"  
 Date 06/01/2023

**A2.4**

Project Number **JWA#611**

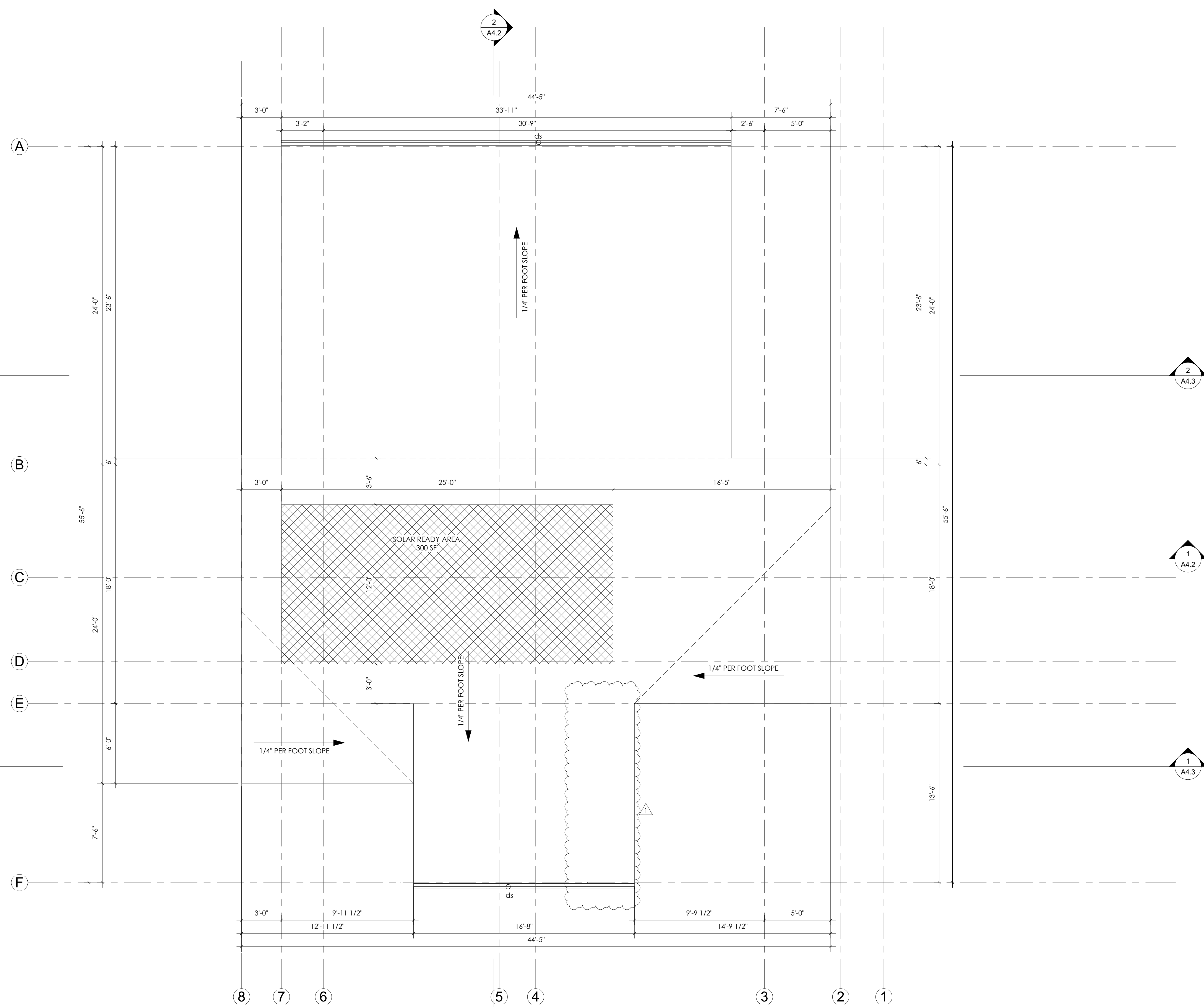

**1 Roof plan**  
 SCALE: 1/4" = 1'-0"

**SOLAR-READY PROVISIONS**

IRC T101: SOLAR-READY PROVISIONS

T101.1 NEW ONE AND TWO FAMILY DWELLINGS SHALL BE PROVIDED WITH A SOLAR-READY ZONE OF NOT LESS THAN 300 SQUARE FEET FOR EACH DWELLING UNIT. TOWNHOUSES SHALL BE PROVIDED WITH A SOLAR-READY ZONE OF NOT LESS THAN 150 SQUARE FEET FOR EACH DWELLING UNIT.

EXCEPTION: THE FOLLOWING DO NOT REQUIRE SOLAR-READY ZONES:

- ONE AND TWO FAMILY DWELLING UNITS WITH LESS THAN 600 SF OF QUALIFYING ROOF AREA CONFORMING TO THE REQUIREMENTS OF SECTION T101.1.1.
- INDIVIDUAL UNITS WITHIN TOWNHOUSE BUILDINGS THAT HAVE LESS THAN 300 SQUARE FEET OF QUALIFYING ROOF AREA PER UNIT CONFORMING TO THE REQUIREMENTS OF SECTION T101.1.1.
- BUILDINGS WITH PERMANENTLY INSTALLED ON-SITE RENEWABLE ENERGY SYSTEMS.

T101.1.1 QUALIFYING ROOF AREA INCLUDES ALL ROOF AREAS OTHER THAN THE FOLLOWING:

- ROOF AREAS ORIENTED WITHIN 45 DEGREES OF TRUE NORTH AND HAVING SLOPES GREATER THAN 2:12
- ROOF AREAS SHADED BY EXISTING LANDFORMS, STRUCTURES OR TREES FOR MORE THAN 70 PERCENT OF THE DAYLIGHT HOURS ANNUALLY.
- ROOF AREAS CONSISTING OF SKYLIGHTS, OCCUPIED DECKS, OR PLANTED AREAS
- ACCESS OR SET-BACK AREAS REQUIRED BY THIS CODE OR THE APPLICABLE PROVISIONS OF THE IFC.

T103.1.1. SOLAR-READY ZONE AREA. NO SOLAR-READY ZONE MAY BE COMPRISED OF ONE SINGLE AREA OR OF MULTIPLE AREAS. NO SOLAR-READY ZONE SHALL BE LESS THAN 5 FEET IN ANY DIMENSION NOR LESS THAN 80 SF OF CONTIGUOUS AREA

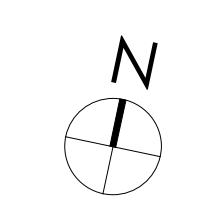

6/17/2023 2:57:34 PM

MATERIAL KEY	
1.	VERTICAL LAP SIDING 4" REVEAL - PAINTED BLACK
2.	4X8 HARDIE PANEL - PAINTED BLACK
3.	VENEER STONE
4.	OPEN JOINT TIMBER BOARDING RAINSCREEN
5.	8X4 HARDIE PANEL - PAINTED WHITE
6.	CEDAR T&G



**JULIAN WEBER ARCHITECTS, LTD**  
 1257 S King St  
 Seattle, WA 98144  
 203.953.1305  
 www.jwaseattle.com

9458 REGISTERED ARCHITECT  
 JULIAN R. WEBER  
 STATE OF WASHINGTON

**COOMBS DEVELOPMENT**  
 4701 SW ADMIRAL WAY, SUITE 385  
 SEATTLE, WA 98116  
 P 206.420.7672

Coombes Residence  
 6221 83rd Pl SE  
 Mercer Island

MUP #	na	
BP #	2207-110	
Δ	Date	Description
1	06.02.2022	BP Submittal
	08.07.2023	PPR 1

**ELEVATIONS**

Scale 1/4" = 1'-0"  
 Date 06/01/2023

**A3.1**

Project Number **JWA#611**

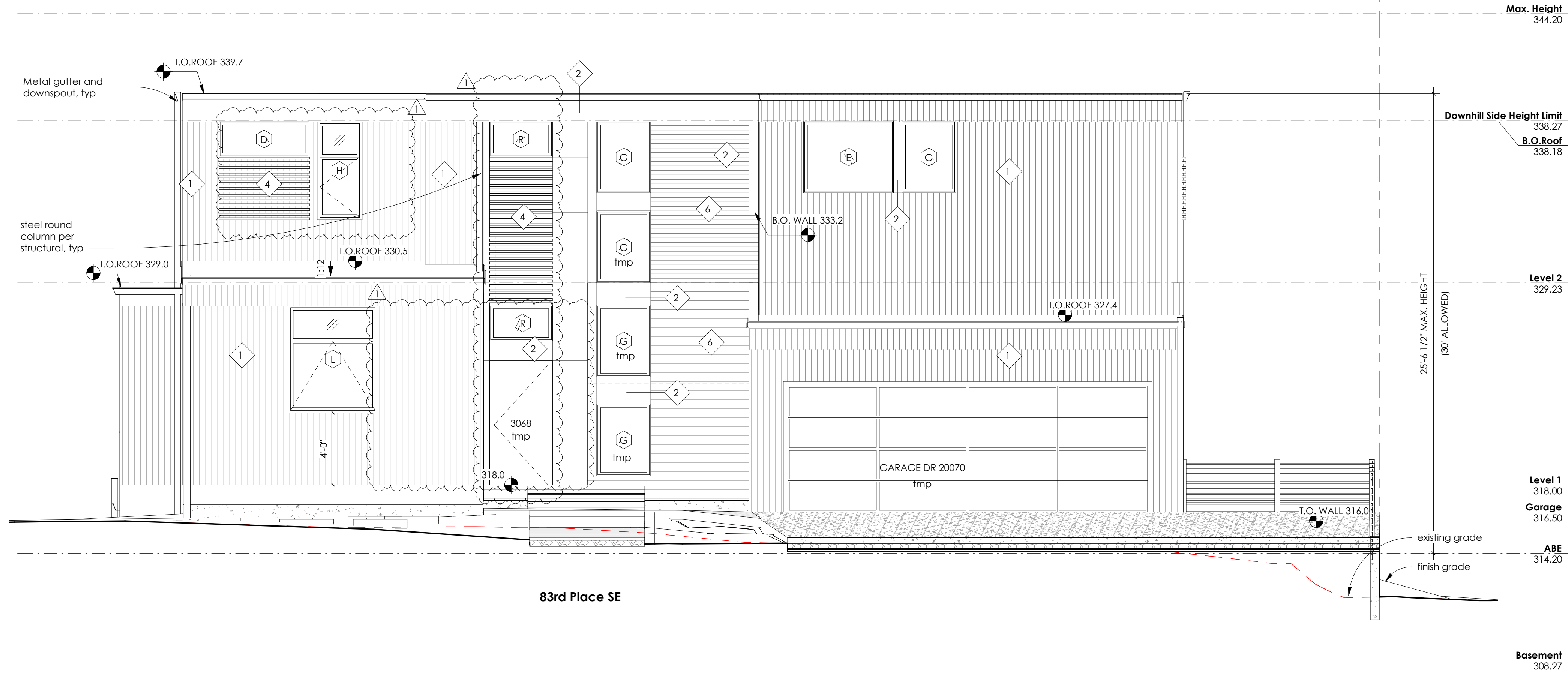

83rd Place SE

**1 East Elevation - 83rd Pl SE**  
 SCALE: 1/4" = 1'-0"

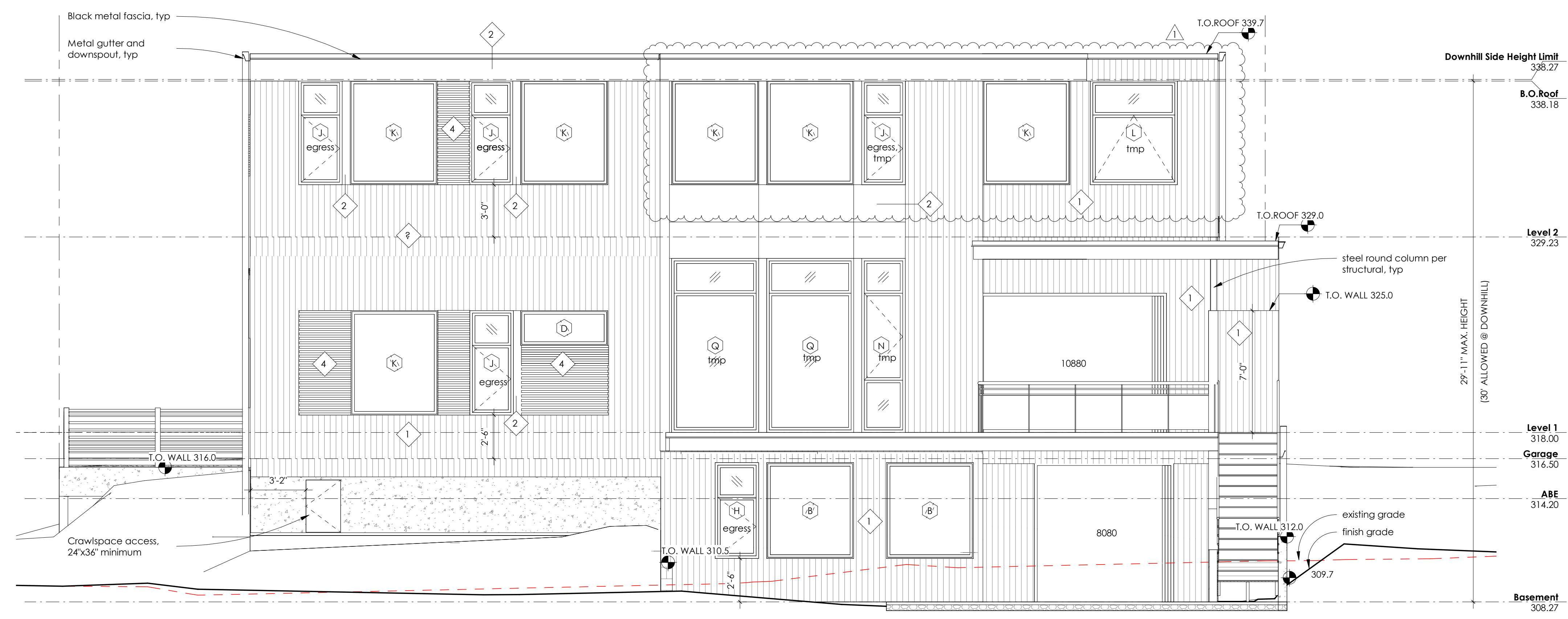

**2 West Elevation**  
 SCALE: 1/4" = 1'-0"

6/7/2023 2:57:35 PM

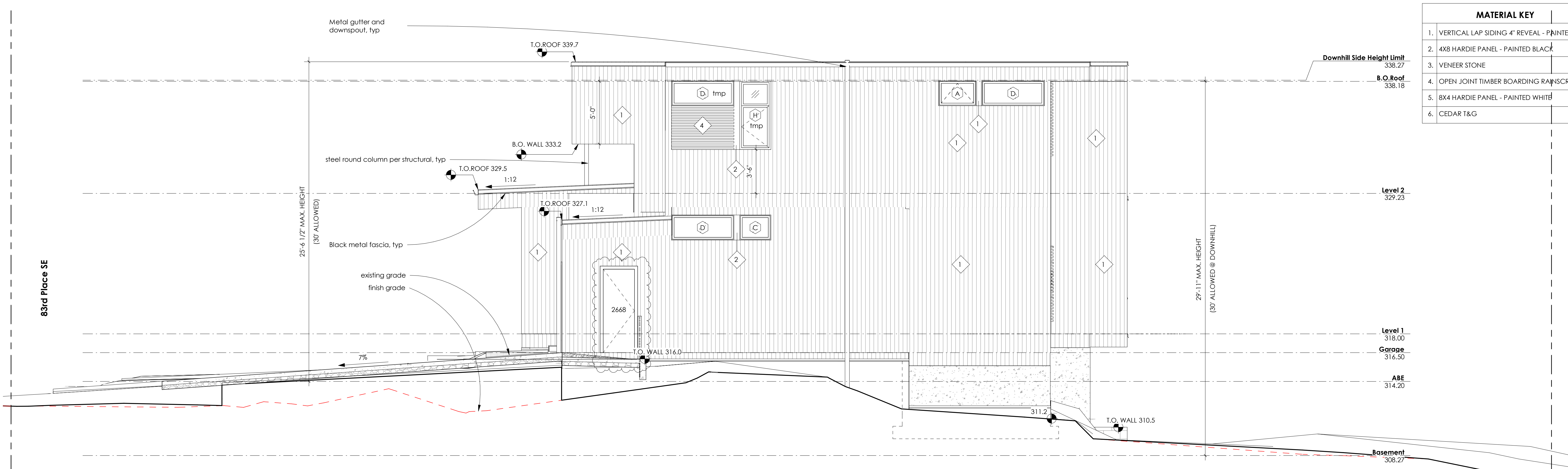

**1 North Elevation**  
SCALE: 1/4" = 1'-0"

MATERIAL KEY	
1.	VERTICAL LAP SIDING 4" REVEAL - PAINTED BLACK
2.	4X8 HARDIE PANEL - PAINTED BLACK
3.	VENEER STONE
4.	OPEN JOINT TIMBER BOARDING RAINTSCREEN
5.	8X4 HARDIE PANEL - PAINTED WHITE
6.	CEDAR T&G

**JULIAN WEBER ARCHITECTS, LTD**  
1257 S King St  
Seattle, WA 98144  
203.953.1305  
www.jwseattle.com

9458 REGISTERED ARCHITECT  
*Julian R. Weber*  
JULIAN R. WEBER  
STATE OF WASHINGTON

**COOMBES DEVELOPMENT**  
4701 SW ADMIRAL WAY, SUITE 385  
SEATTLE, WA 98116  
P 206.420.7672

Coombes Residence  
6221 83rd Pl SE  
Mercer Island

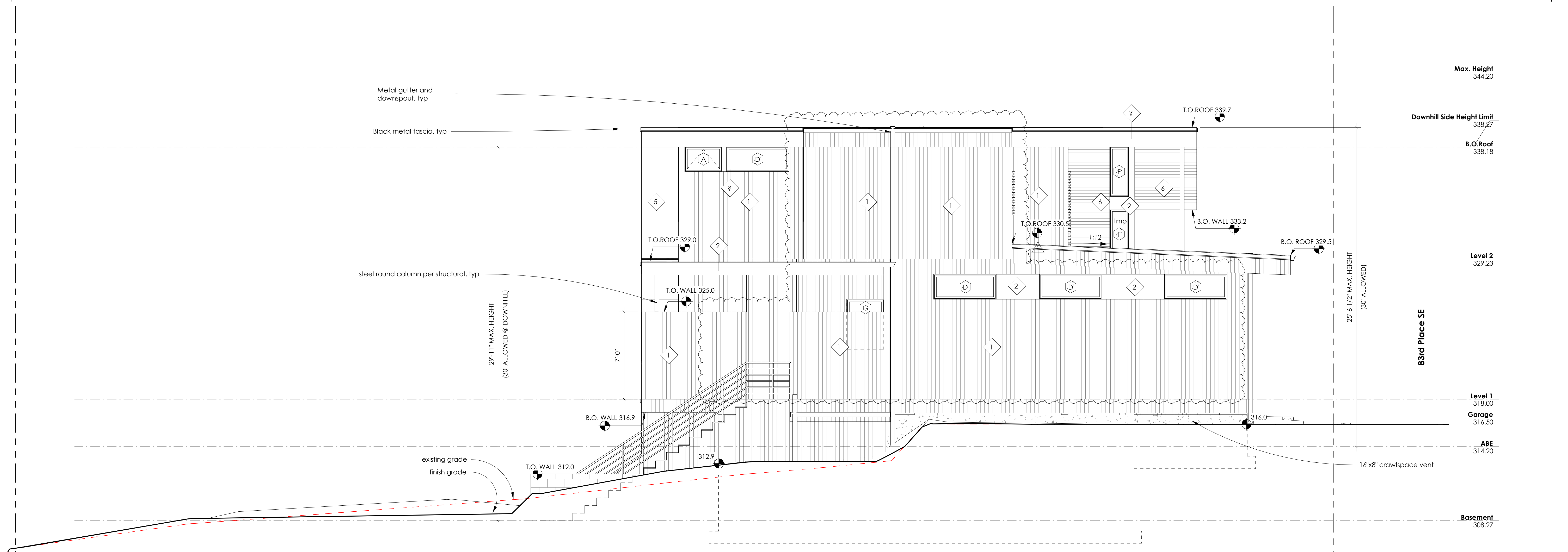

**2 South Elevation**  
SCALE: 1/4" = 1'-0"

MUP #	na	
BP #	2207-110	
Δ	Date	Description
1	06.02.2022	BP Submittal
1	08.07.2023	PPR 1

**ELEVATIONS**

Scale: 1/4" = 1'-0"  
Date: 06/01/2023

**A3.2**

Project Number: JWA#611





# WALL ASSEMBLIES

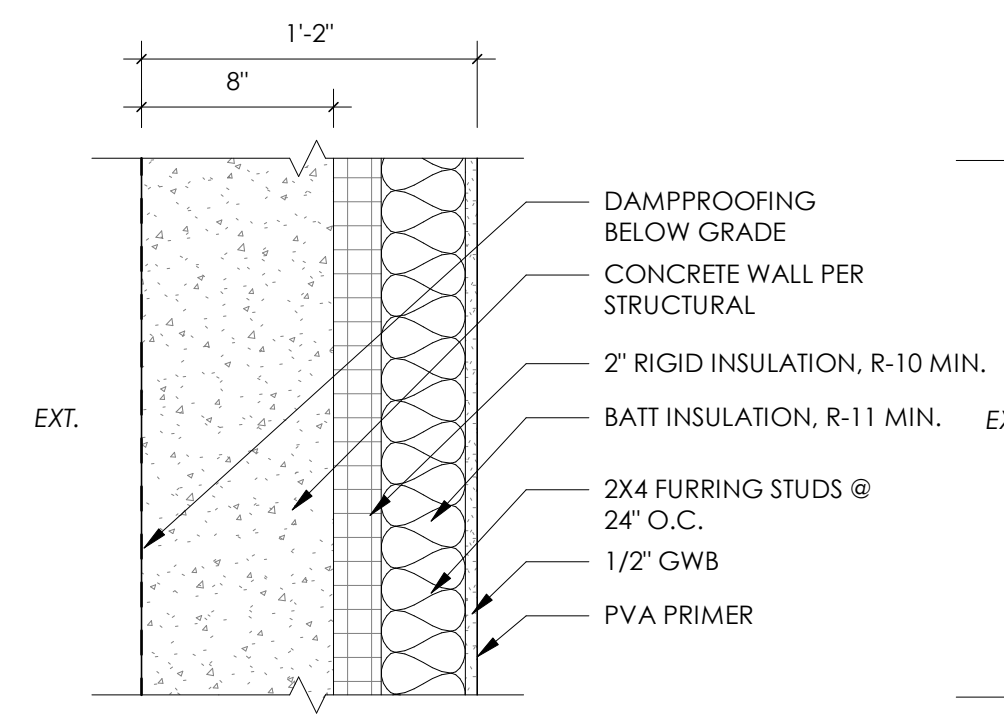

**W1** BELOW GRADE FURRED WALL

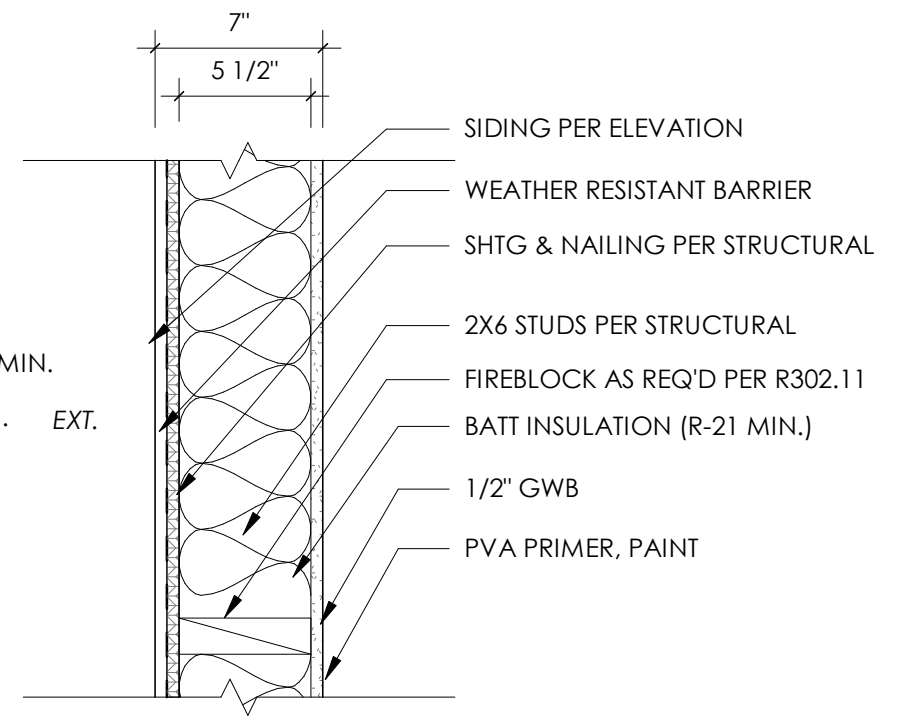

**W2** EXTERIOR WALL

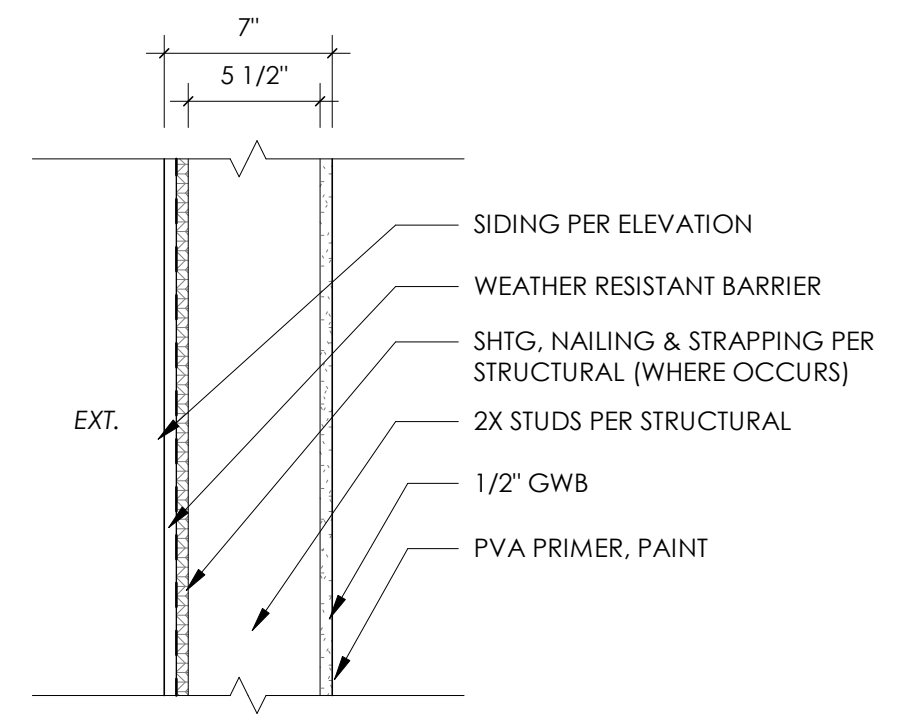

**W3** UNINSULATED EXTERIOR WALL

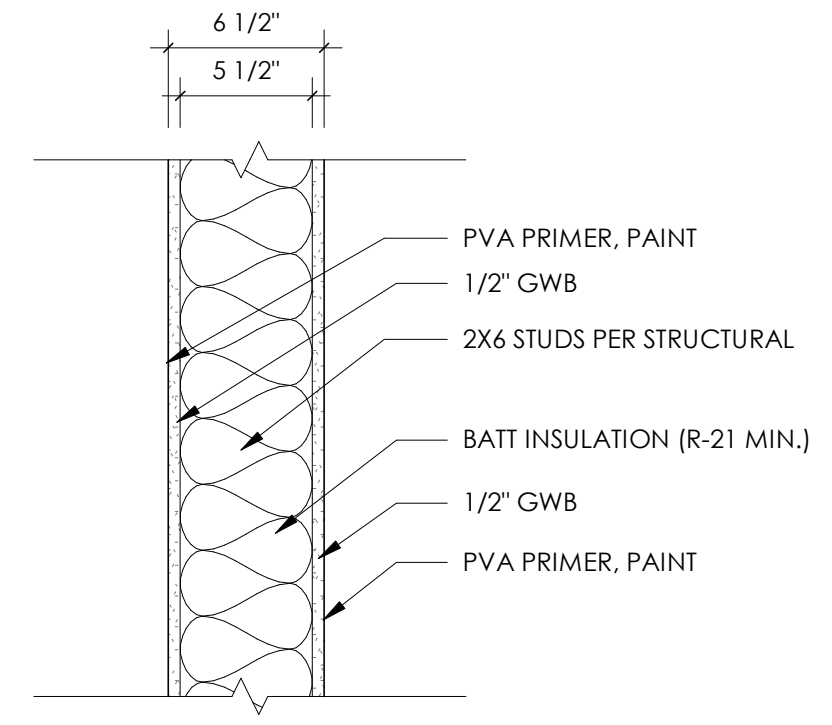

**W4** WALL @ GARAGE/LIVING SPACE

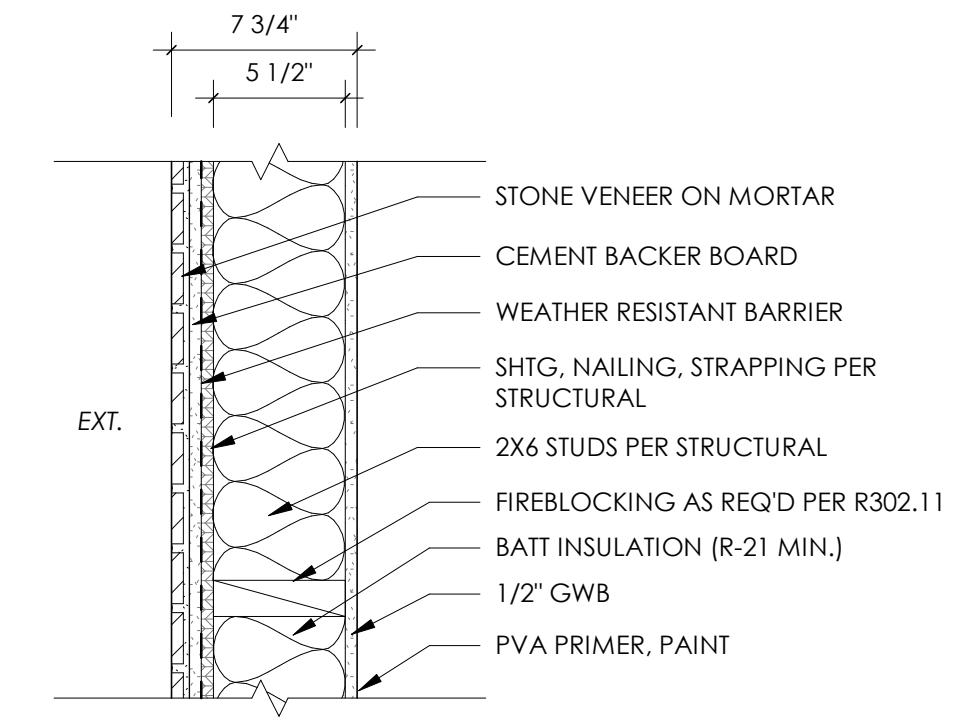

**W5** EXTERIOR WALL W/ STONE VENEER

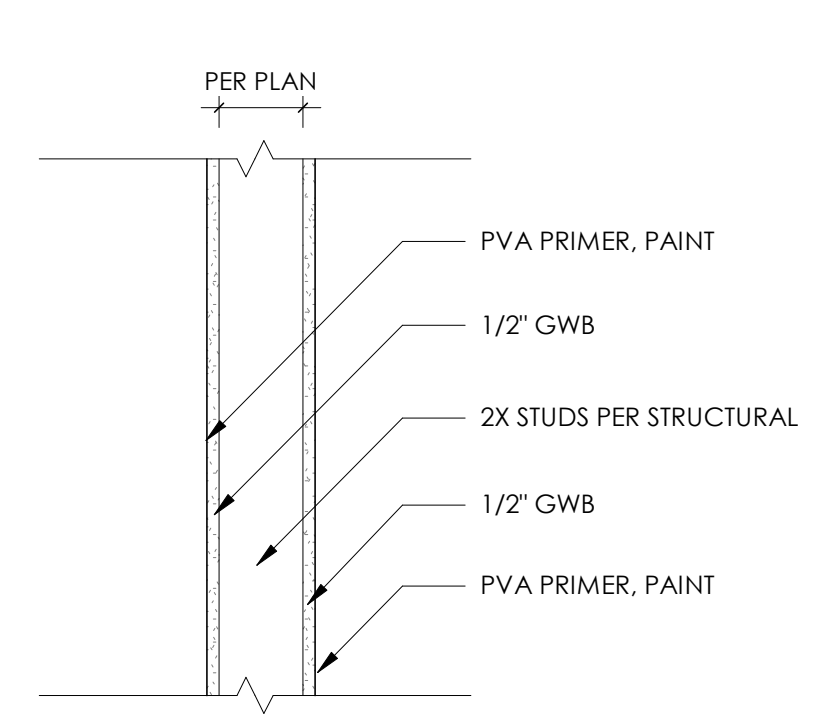

**W6** INTERIOR WALL

# FLOOR ASSEMBLIES

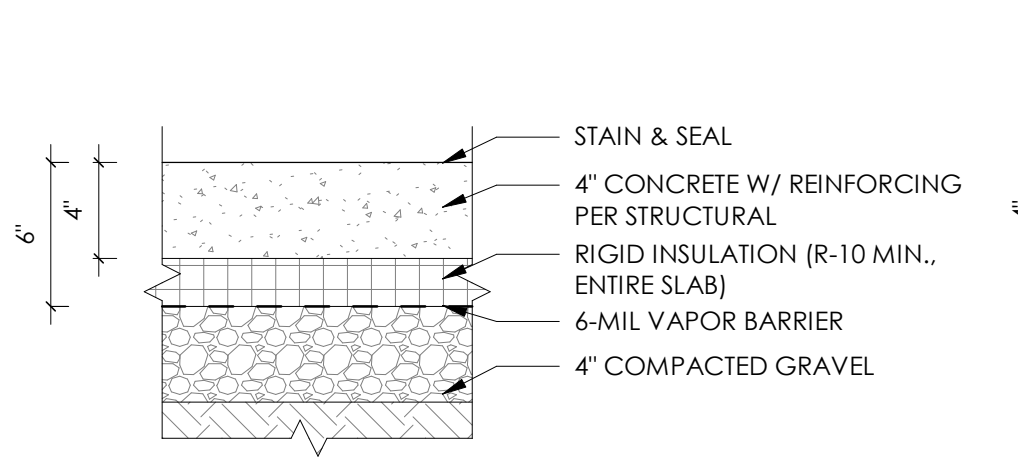

**F1** SLAB ON GRADE - INSULATED

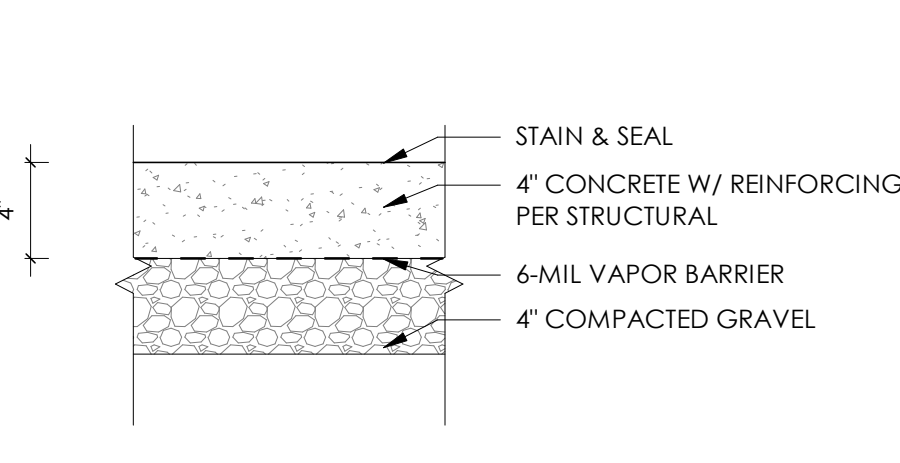

**F2** SLAB ON GRADE @ GARAGE

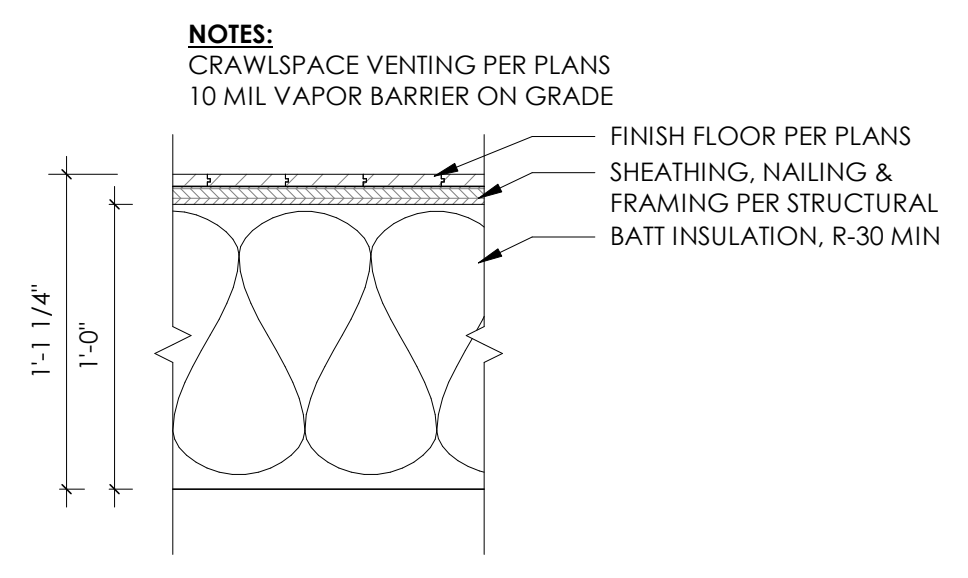

**F3** FLOOR OVER CRAWLSPACE

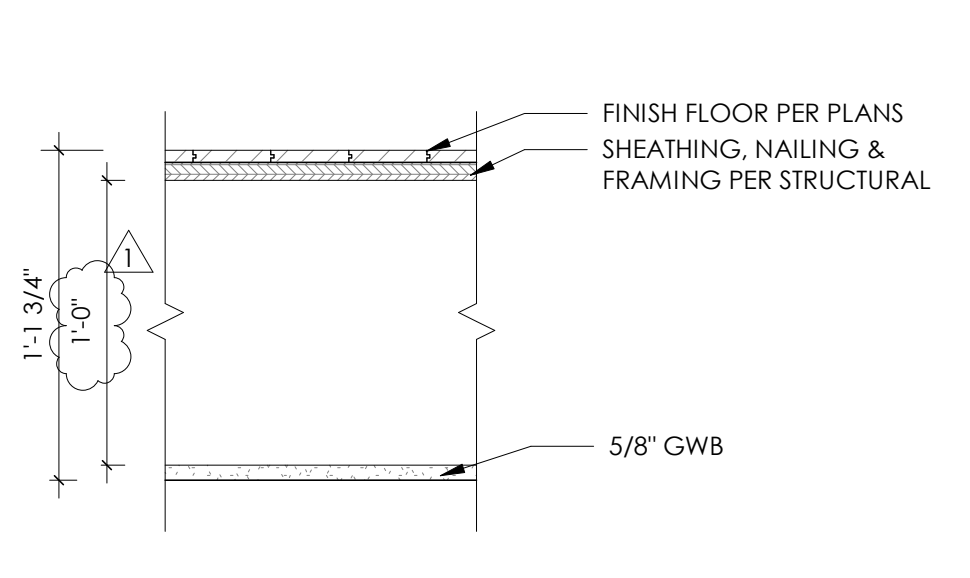

**F4** UPPER FLOOR

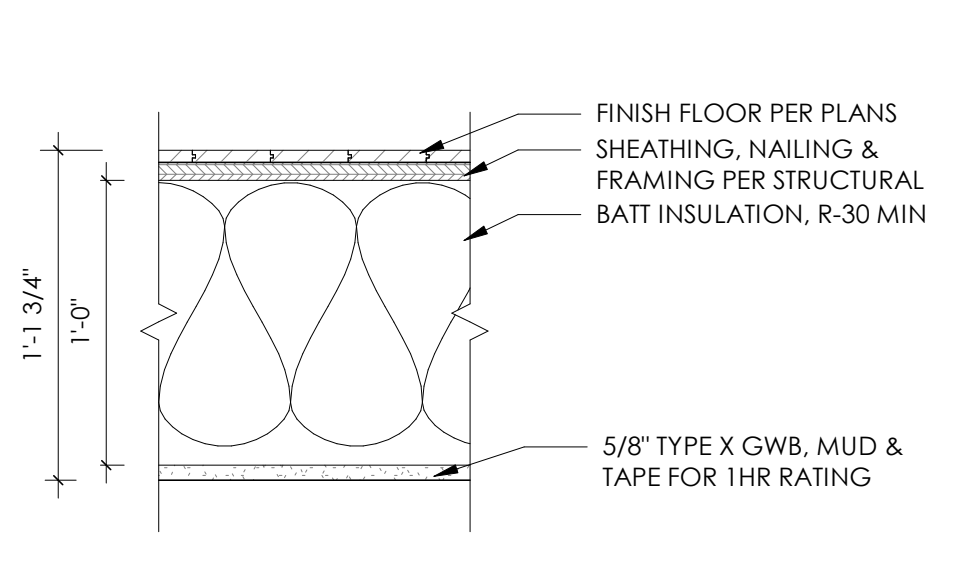

**F5** FLOOR OVER GARAGE

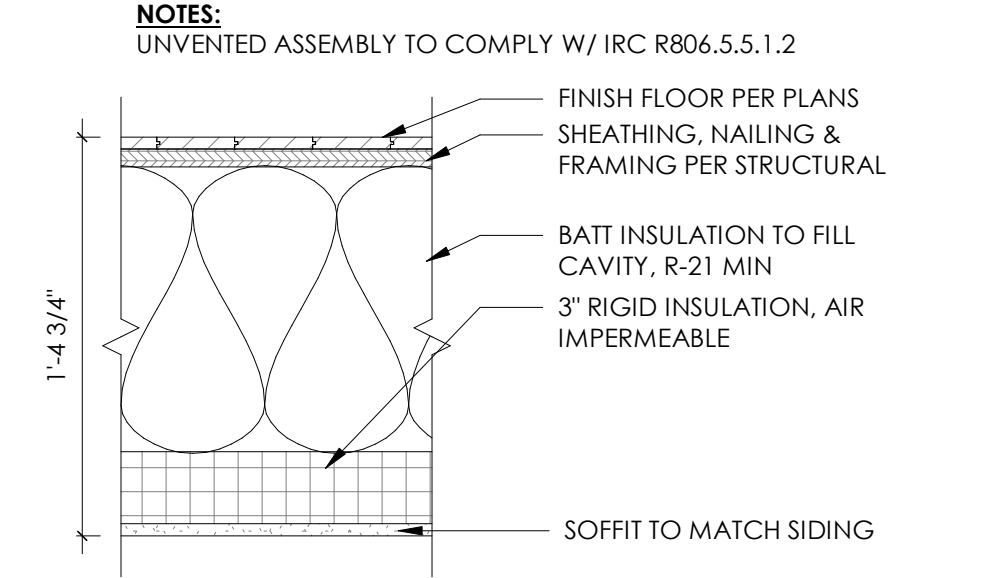

**F6** CANTILEVERED FLOOR - UNVENTED

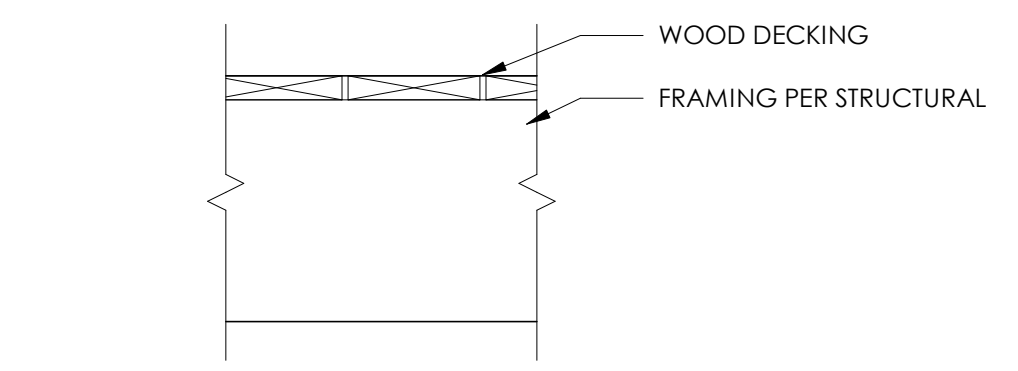

**F7** OPEN DECK

# ROOF ASSEMBLIES

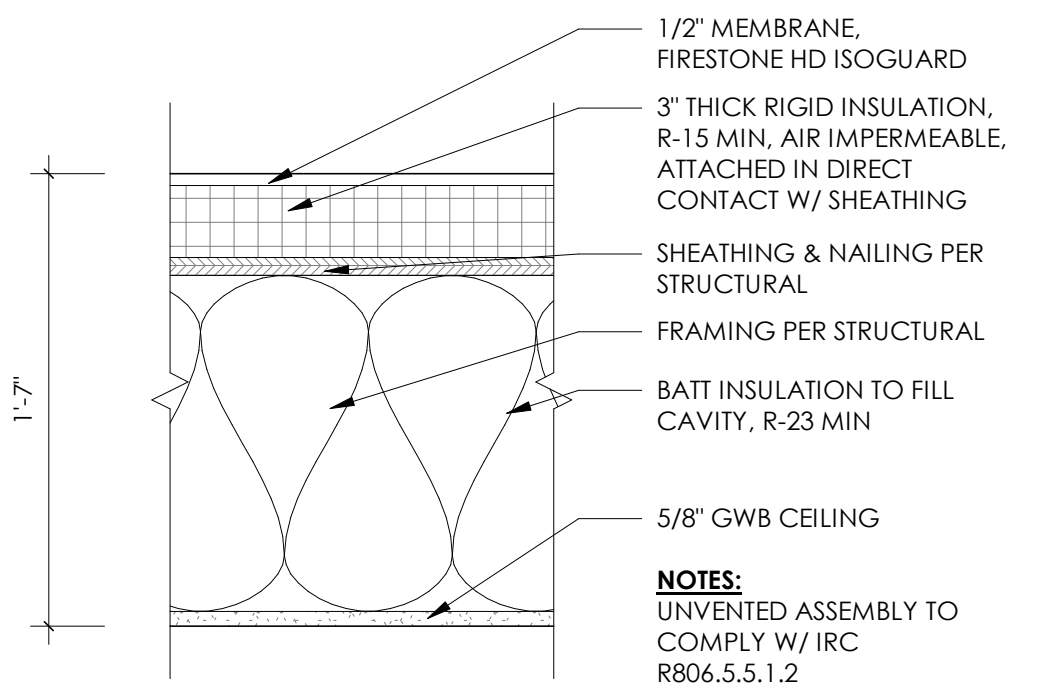

**R1** TJI - UNVENTED

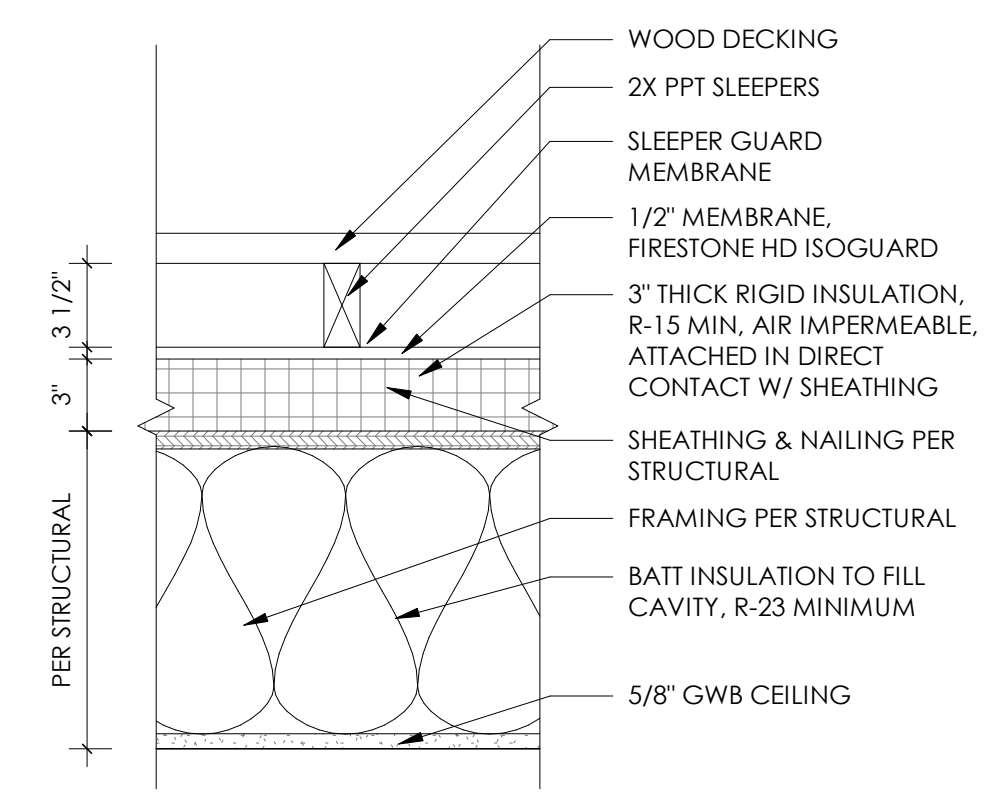

**R2** ROOF W/ DECKING

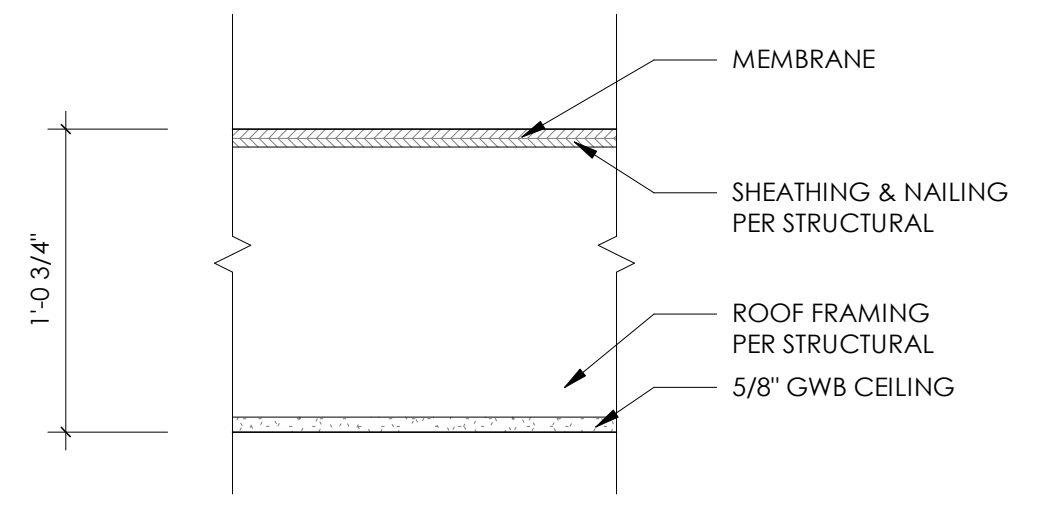

**R3** 2X12 UNHEATED SPACE



**JULIAN WEBER ARCHITECTS, LTD**  
1257 S King St  
Seattle, WA 98144  
206.953.1305  
www.jwaseattle.com

9458 REGISTERED ARCHITECT  
**JULIAN R. WEBER**  
STATE OF WASHINGTON

**COOMBS DEVELOPMENT**  
4701 SW ADMIRAL WAY, SUITE 385  
SEATTLE, WA 98116  
P 206.420.7672

**Coombes Residence**  
6221 83rd Pl SE  
Mercer Island

MUP #	na	
BP #	2207-110	
Δ	Date	Description
1	06.02.2022	BP Submittal
	08.07.2023	PPR 1

## ASSEMBLIES

Scale 1 1/2" = 1'-0"  
Date 06/01/2023

**A4.1**

Project Number **JWA#611**



**JULIAN WEBER ARCHITECTS, LTD**  
 1257 S King St  
 Seattle, WA 98144  
 203.953.1305  
 www.jwseattle.com

9458 REGISTERED ARCHITECT  
*Julian Weber*  
 JULIAN R. WEBER  
 STATE OF WASHINGTON

**COOMBS DEVELOPMENT**  
 4701 SW ADMIRAL WAY, SUITE 385  
 SEATTLE, WA 98116  
 P 206.420.7672

**Coombes Residence**  
 6221 83rd Pl SE  
 Mercer Island

MUP #	na
BP #	2207-110
Δ	Date Description
1	06.02.2022 BP Submittal
1	08.07.2023 PPR 1

**BUILDING SECTION**

Scale 1/4" = 1'-0"  
 Date 06/01/2023

**A4.2**

Project Number **JWA#611**

6/17/2023 2:57:39 PM

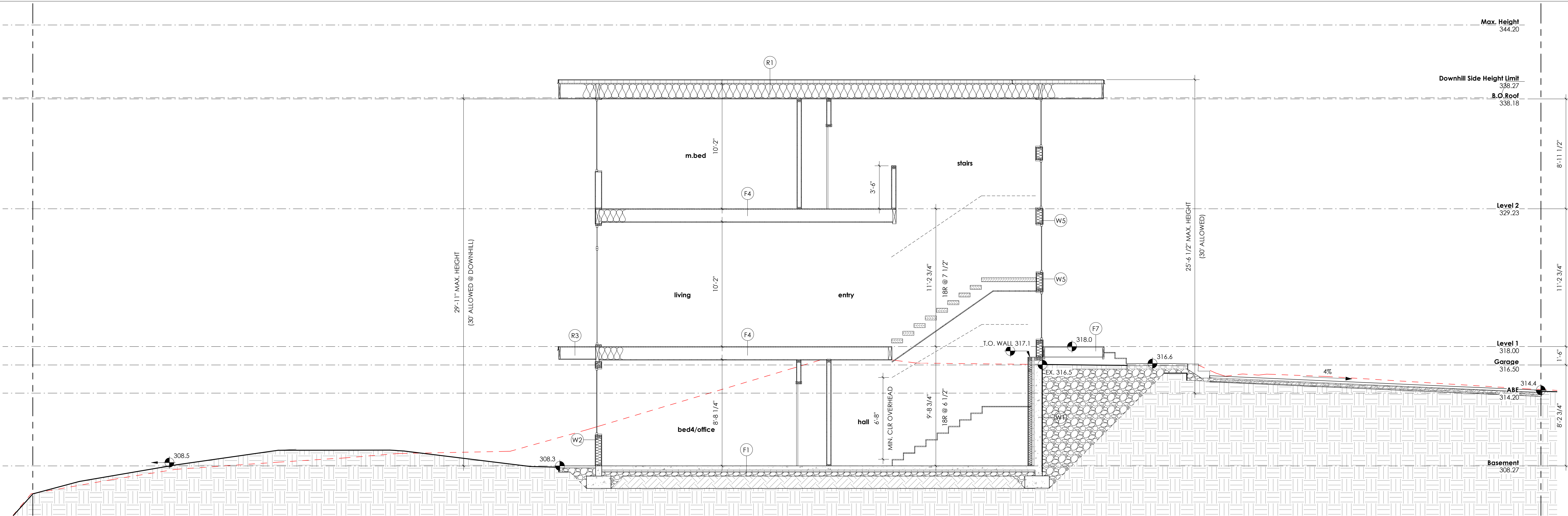

**1 Section 1 Stairs**  
 SCALE: 1/4" = 1'-0"

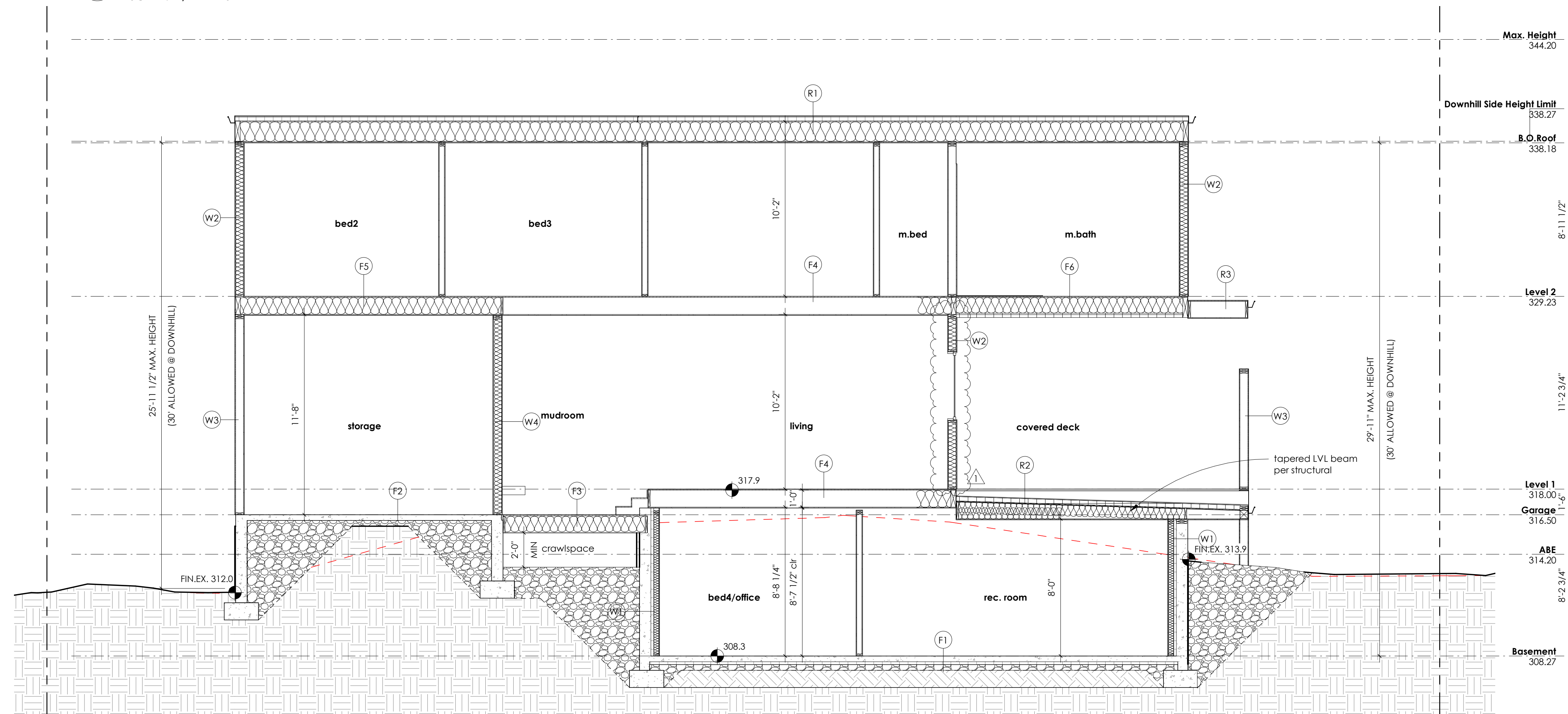

**2 Section 2**  
 SCALE: 1/4" = 1'-0"

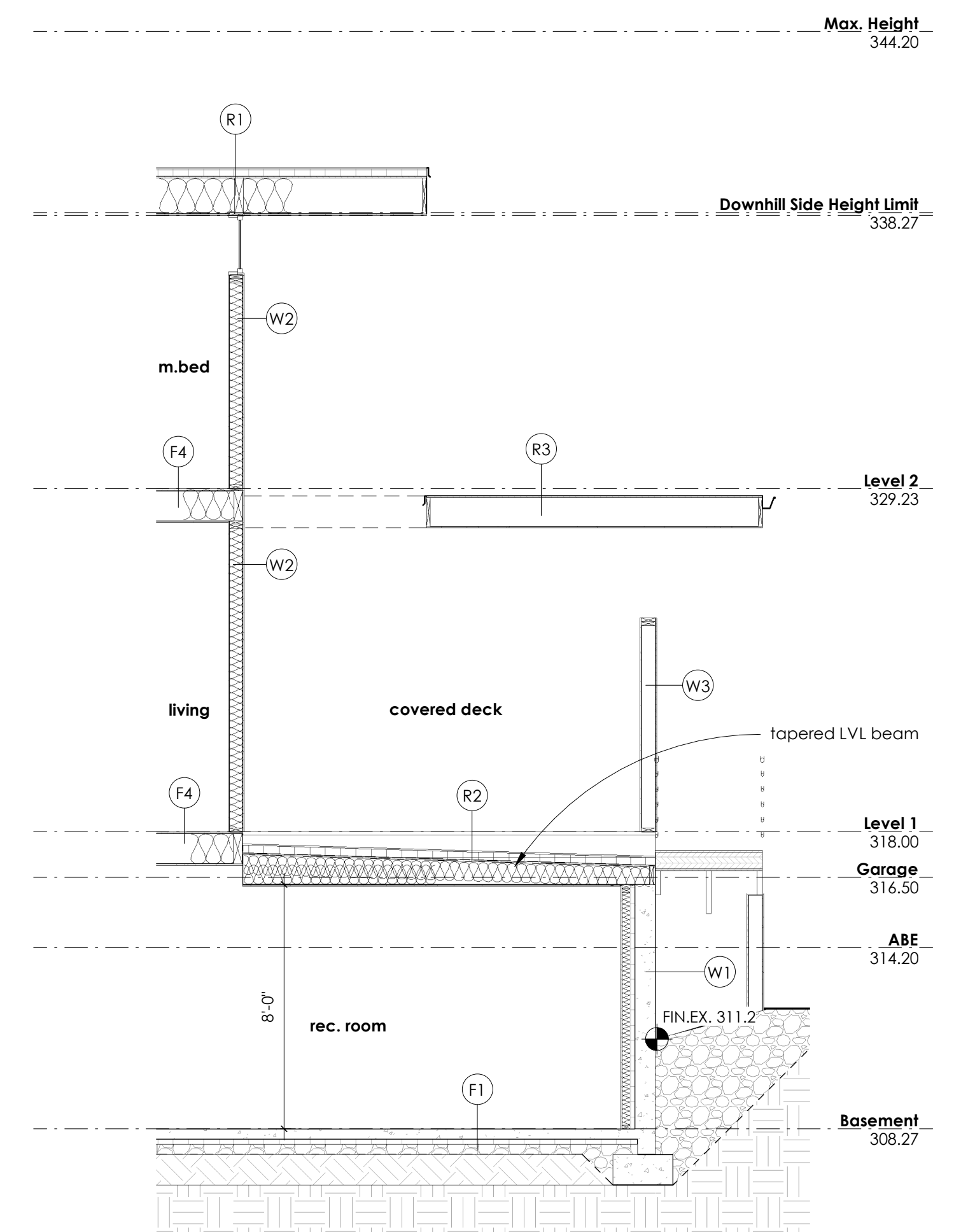

**3 Partial Section 3 - Covered Deck**  
 SCALE: 1/4" = 1'-0"



**JULIAN WEBER ARCHITECTS, LTD**  
 1257 S King St  
 Seattle, WA 98144  
 203.953.1305  
 www.jwaseattle.com

9458 REGISTERED ARCHITECT  
*Julian R. Weber*  
 JULIAN R. WEBER  
 STATE OF WASHINGTON

**COOMBES DEVELOPMENT**  
 4701 SW ADMIRAL WAY, SUITE 385  
 SEATTLE, WA 98116  
 P 206.420.7672

**Coombes Residence**  
 6221 83rd Pl SE  
 Mercer Island

MUP #	na	
BP #	2207-110	
Δ	Date	Description
1	06.02.2022	BP Submittal
1	08.07.2023	PPR 1

**BUILDING SECTION**

Scale 1/4" = 1'-0"  
 Date 06/01/2023

**A4.3**

Project Number **JWA#611**

6/7/2023 2:57:40 PM

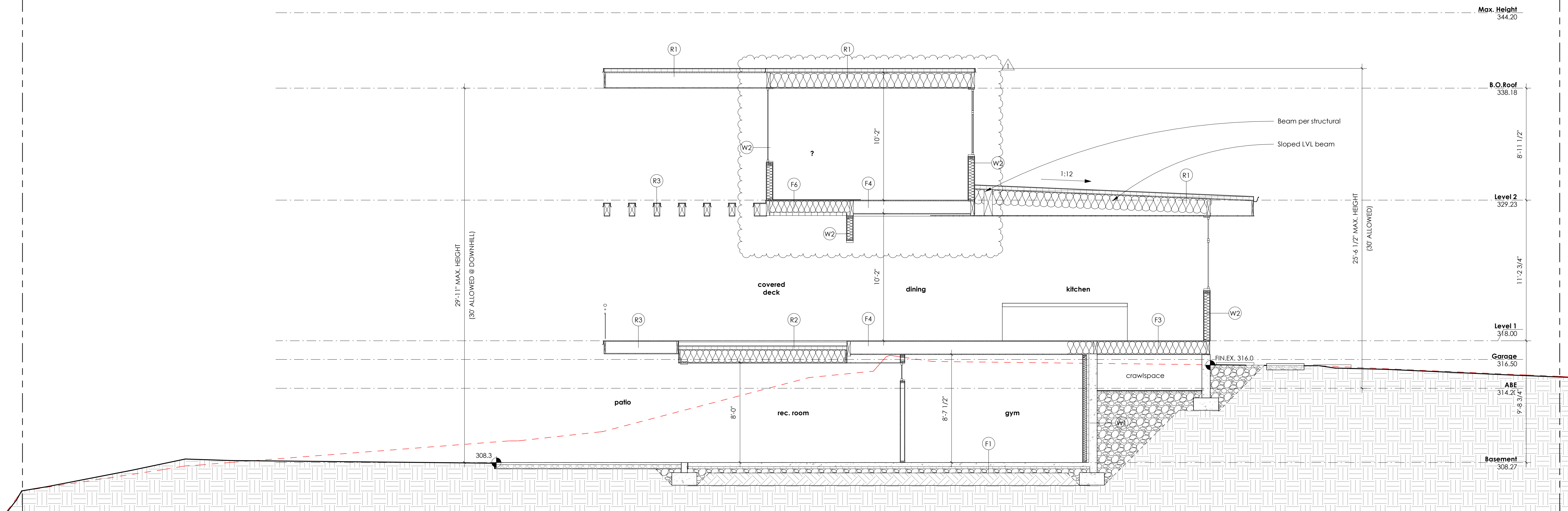

**1 Section 4 Covered Deck**  
 SCALE: 1/4" = 1'-0"

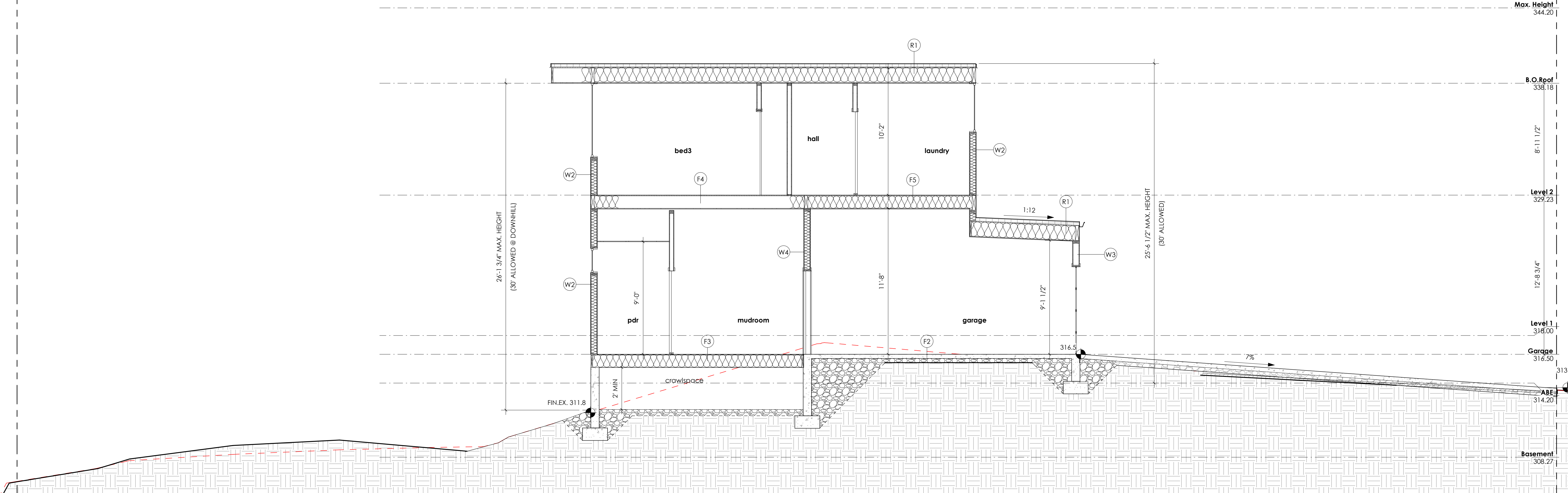

**2 Section 4 Garage**  
 SCALE: 1/4" = 1'-0"

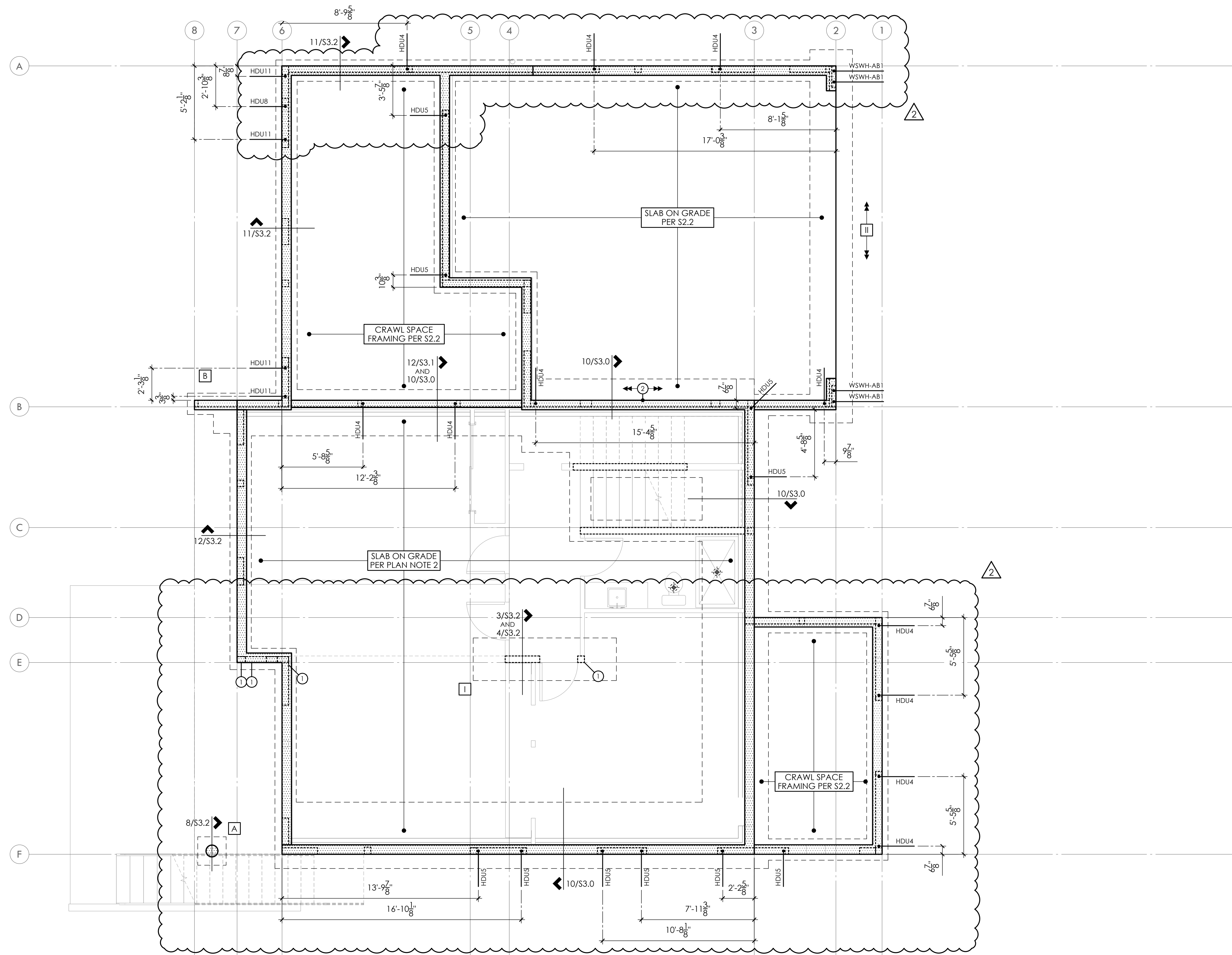

**PLAN NOTES**

1. BOTTOM OF ALL FOOTINGS SHALL BE 18" MINIMUM BELOW LOWEST ADJACENT GRADE, UNO.
2. SLAB ON GRADE SHALL BE 4" MINIMUM THICKNESS. REINFORCE WITH 6x6 W1.4 x W1.4 WWM CENTERED IN SLAB. PROVIDE RIGID INSULATION AT INTERIOR SPACES AND VAPOR BARRIER BELOW SLAB PER ARCHITECTURAL DRAWINGS OVER 4" MINIMUM FREE DRAINING GRAVEL OVER FIRM NATIVE SOILS OR STRUCTURAL FILL PER SOILS ENGINEER.
3. REFER TO SHEET S3.0 FOR TYPICAL FOUNDATION AND CONCRETE DETAILS.
4. STD HOLD-DOWNS ARE DIMENSIONED TO THE CENTERLINE OF STRAP. HDU HOLD-DOWNS ARE DIMENSIONED TO THE CENTERLINE OF ANCHOR BOLT. DIMENSIONS ARE BASED OFF OF DRAWINGS PROVIDED BY THE ARCHITECT AND SHOULD BE VERIFIED.
5. REFER TO GENERAL STRUCTURAL NOTES SHEET S1.0 FOR ADDITIONAL REQUIREMENTS.
6. DO NOT SCALE DRAWINGS. REFER TO ARCHITECTURAL DRAWINGS FOR ALL DIMENSIONS.

**LEGEND**

- CONCRETE WALL BELOW
- STRUCTURAL WALL ABOVE
- SPAN AND EXTENTS
- HEADER/BEAM BELOW FRAMING - TYP
- NUMBER OF BUILT UP STUDS
- PLUMBING PENETRATION ABOVE
- HORIZ CS16 x 3'-0" - BEAM TO BEAM

**FOOTNOTES**

- POST ABOVE TO BEAR DIRECTLY ON FOUNDATION w/ (2) LAYERS OF BUILDING PAPER AND (2) A35 TO BOTTOM PLATE
- CONSTRUCT RETAINING WALL FOR H+2' PER 10/S3.0 FOR VEHICULAR SURCHARGE

**FOUNDATION PLAN**

BASEMENT WALLS SHOWN DASHED

**FOOTING SCHEDULE**

MARK	SIZE	REINFORCING
A	2'-0" SQ x 8" DP	(3) #4 EW BOT
B	4'-0" SQ x 16" DP	(7) #4 EW BOT
I	CONT 3'-0" W x 10'-0" L x 16" DP	#5 AT 8" OC BOT
II	CONT 3'-0" W x 18" DP	#5 AT 6" OC TOP AND BOT

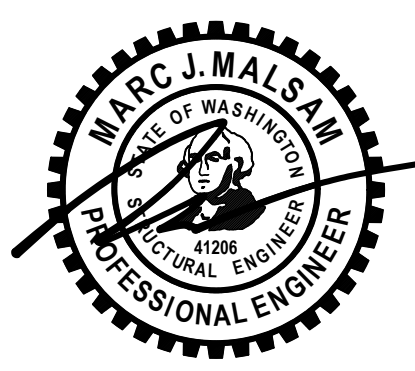

PROJECT NO 0329.2022.01.01  
 PROJECT MANAGER WAC  
 DRAWN JSD  
 ENGINEER BLAKE RASSILYER  
 206.602.5452  
 BLAKER@MALSAM-TSANG.COM

REV	DESCRIPTION	DATE
	PERMIT SET	5.27.22
	PERMIT CORRECTIONS	1.6.23
	POST PERMIT REVISIONS	8.1.23

ARCH JULIAN WEBER ARCH + DESIGN  
 206.953.1305  
 CLIENT COOMBES DEVELOPMENT

**FOUNDATION PLAN**

**S2.1**  
 SCALE - 1/4" = 1'-0"

COPYRIGHT © 2020 MALSAM TSANG ENGINEERING CORPORATION - ALL RIGHTS RESERVED

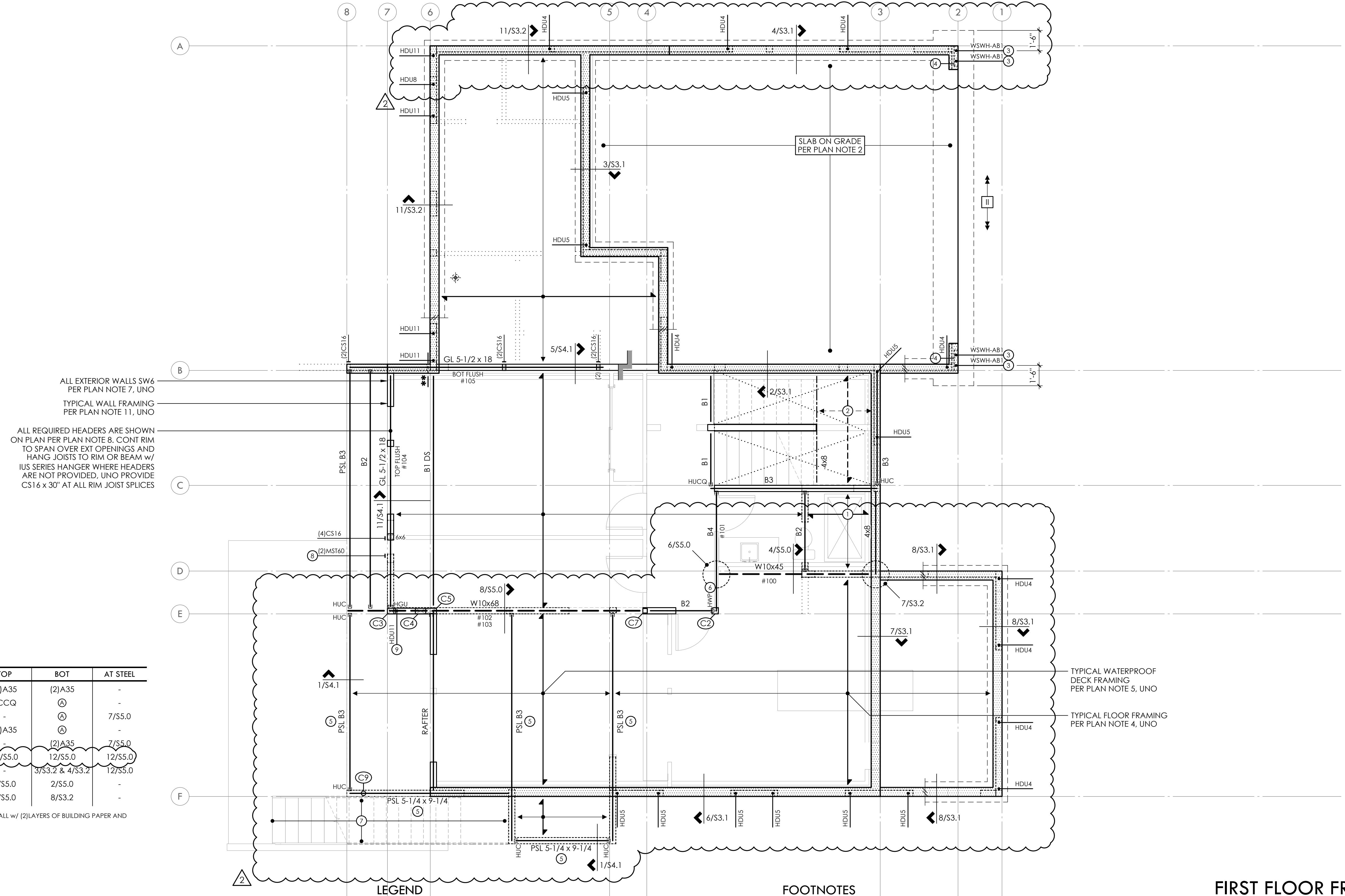

ALL EXTERIOR WALLS SW6  
PER PLAN NOTE 7, UNO  
TYPICAL WALL FRAMING  
PER PLAN NOTE 11, UNO

ALL REQUIRED HEADERS ARE SHOWN  
ON PLAN PER PLAN NOTE 8. CONT RIM  
TO SPAN OVER EXT OPENINGS AND  
HANG JOISTS TO RIM OR BEAM w/  
IUS SERIES HANGER WHERE HEADERS  
ARE NOT PROVIDED, UNO PROVIDE  
CS16 x 30" AT ALL RIM JOIST SPLICES

**COLUMN SCHEDULE**

MARK	SIZE	TOP	BOT	AT STEEL
C1	PSL 5-1/4 x 5-1/4	(2)A35	(2)A35	-
C2	PSL 5-1/4 x 5-1/4	ECCQ	A	7/S5.0
C3	PSL 5-1/4 x 7	-	A	-
C4	PSL 5-1/4 x 9-1/4	(2)A35	A	-
C5	PSL 5-1/4 x 9-1/4	-	(2)A35	7/S5.0
C6	HSS 4x4x1/4	10/S5.0	12/S5.0	12/S5.0
C7	HSS 4x4x1/4	-	3/S3.2 & 4/S3.2	12/S5.0
C8	HSS 4Ø x 0.22	3/S5.0	2/S5.0	-
C9	HSS 4Ø x 0.22	3/S5.0	8/S3.2	-

A POST TO BEAR DIRECTLY ON FOUNDATION WALL w/ (2) LAYERS OF BUILDING PAPER AND (2) A35 TO SILL PLATE

**PLAN NOTES**

- BOTTOM OF ALL FOOTINGS SHALL BE 18" MINIMUM BELOW LOWEST ADJACENT GRADE, UNO.
- SLAB ON GRADE SHALL BE 4" MINIMUM THICKNESS. REINFORCE WITH 6x6 W1.4 x W1.4 WWM CENTERED IN SLAB. PROVIDE RIGID INSULATION AT INTERIOR SPACES AND VAPOR BARRIER BELOW SLAB PER ARCHITECTURAL DRAWINGS OVER 4" MINIMUM FREE DRAINING GRAVEL OVER FIRM NATIVE SOILS OR STRUCTURAL FILL PER SOILS ENGINEER.
- REFER TO SHEET S3.0 FOR TYPICAL FOUNDATION AND CONCRETE DETAILS.
- TYPICAL FLOOR FRAMING CONSISTS OF 3/4" T&G APA RATED SHEATHING (SPAN RATING 48/24) OVER TJI'S PER JOIST SCHEDULE. UNO. PROVIDE DOUBLE JOISTS UNDER ALL PARALLEL PARTITIONS THAT EXTEND OVER MORE THAN HALF THE JOIST LENGTH.
- TYPICAL WATER PROOF DECK FRAMING CONSISTS OF 3/4" T&G APA RATED SHEATHING (SPAN RATING 48/24) OVER LVL 1-3/4 x 11-7/8 AT 16"oc. UNO. JOISTS CAN BE TAPERED TO A MIN DEPTH OF 8".
- GLUE AND NAIL FLOOR SHEATHING w/ 8d AT 6"oc AT FRAMED PANEL EDGES AND AT 12"oc IN THE FIELD, UNO.
- "SW" INDICATES SHEARWALL BELOW FRAMING SHOWN. REFER TO SHEARWALL SCHEDULE ON 4/S4.0 FOR ADDITIONAL INFORMATION. ALL EXTERIOR WALLS ARE SW6, UNO.
- ALL REQUIRED HEADERS ARE SHOWN ON PLAN AND SHALL BE (2) 2x8. UNO. REFER TO DETAIL 8/S4.0 FOR ADDITIONAL REQUIREMENTS.
- PROVIDE (2) BEARING (TRIMMER) STUDS AT EACH END OF ALL HEADERS AND BEAMS 6'-0" IN LENGTH AND OVER, UNO.
- WHERE POSTS OCCUR, PROVIDE SOLID VERTICAL GRAIN BLOCKING THRU FLOOR TO MATCHING SUPPORTS BELOW, UNO.
- TYPICAL WALL FRAMING CONSISTS OF 2x6's AT 16"oc AT EXTERIOR WALLS AND 2x4's or 2x6's AT 16"oc AT INTERIOR WALLS PER ARCH DRAWINGS, UNO.
- REFER TO SHEET S4.0 FOR TYPICAL WOOD FRAMING DETAILS.
- STHD HOLDOWNS ARE DIMENSIONED TO THE CENTERLINE OF STRAP. HDU HOLDOWNS ARE DIMENSIONED TO THE CENTERLINE OF ANCHOR BOLT. DIMENSIONS ARE BASED OFF OF DRAWINGS PROVIDED BY THE ARCHITECT AND SHOULD BE VERIFIED.
- REFER TO GENERAL STRUCTURAL NOTES SHEET S1.0 FOR ADDITIONAL REQUIREMENTS.
- DO NOT SCALE DRAWINGS. REFER TO ARCHITECTURAL DRAWINGS FOR ALL DIMENSIONS.

**LEGEND**

- CONCRETE WALL BELOW
- STRUCTURAL WALL BELOW
- STRUCTURAL WALL ABOVE
- SPAN AND EXTENTS
- HEADER/BEAM BELOW FRAMING - TYP
- NUMBER OF BUILT UP STUDS
- PLUMBING PENETRATION ABOVE
- HORIZ CS16 x 3'-0" - BEAM TO BEAM
- (2) HORIZ CS16 x 3'-0" - BEAM TO BEAM

**FOOTNOTES**

- WATER PROOF DECK FRAMING CONSISTS OF 3/4" T&G APA RATED SHEATHING (SPAN RATING 48/24) OVER 2x10's AT 24"oc. UNO. JOISTS CAN BE TAPERED TO A MIN DEPTH OF 8"
- LANDING FRAMING CONSISTS OF 2x8's AT 16"oc w/ LUS HANGER TO 2X LEDGER w/ (2) 0.22" Ø x 6" SDWS TIMBER SCREWS AT 16"oc INTO EA STUD
- LOCATE ANCHOR BOLT FOR WSWH ABOVE USING WSWH-RT ANCHOR BOLT TEMPLATE - PROVIDE WSWH-HSR EXTENSION KIT AS REQUIRED TO EXTEND TO FOOTING BELOW w/ 12" EMBEDMENT
- PROVIDE ADDITIONAL STEMWALL REINFORCEMENT AT WSWH PER MANUFACTURER'S REQUIREMENTS
- NOTCH AND TAPER BEAM TO MATCH JOIST DEPTH - 8" MIN, NO OVERCUTS
- OFFSET TOP FLANGE HANGER
- PREFABRICATED STAIR ASSEMBLY BY OTHERS BY DEFERRED SUBMITTAL
- INSTALL HOLDOWN STRAP TO FACE OF BEAM FOR FULL DEPTH OF BEAM
- PROVIDE ALL-THREAD TO MATCH AB SIZE IN HOLDOWN SCHEDULE - WELD TO TOP OF STEEL BEAM PER 1/S5.0

**FOOTING SCHEDULE**

MARK	SIZE	REINFORCING
A	2'-0" SQ x 8" DP	(3) #4 EW BOT
B	4'-0" SQ x 16" DP	(7) #4 EW BOT
I	CONT 3'-0" W x 10'-0" L x 16" DP	#5 AT 8"oc BOT
II	CONT 3'-0" W x 18" DP	#5 AT 6"oc TOP AND BOT

**FIRST FLOOR FRAMING PLAN**

FIRST FLOOR WALLS SHOWN DASHED  
BASEMENT WALLS SHOWN SOLID

**FLUSH BEAM SCHEDULE**

MARK	SIZE	BRG STUDS	HANGER
B1	LSL 1-3/4 x 11-7/8	2	HUS1.81/10
B2	GL 3-1/2 x 11-7/8 OR LSL 3-1/2 x 11-7/8	2	HHUS410 HHUS410
B3	GL 5-1/2 x 11-7/8 OR PSL 5-1/4 x 11-7/8	3	HGUS5.50/10 HGUS5.50/10
B4	PSL 7 x 11-7/8	4	HGUS7.25/10

① ALL GLULAM BEAMS ARE 24F-V4 - UNO  
② PROVIDE HUC410 WHERE REQUIRED - UNO

**JOIST SCHEDULE**

MAX LENGTH	SIZE	SPACING	FACE MOUNT HANGER	TOP FLANGE HANGER
18'-0"	11-7/8" TJI 110	16"oc	IUS1.81/11.88	ITS1.81/11.88
18'-9"	11-7/8" TJI 210	16"oc	IUS2.06/11.88	ITS2.06/11.88
19'-3"	11-7/8" TJI 230	16"oc	IUS2.37/11.88	ITS2.37/11.88
20'-0"	11-7/8" TJI 360	16"oc	IUS2.37/11.88	ITS2.37/11.88
22'-0"	11-7/8" TJI 560	16"oc	IUS3.56/11.88	ITS3.56/11.88

① DESIGN BASED ON DL=15 PSF, LL=40 PSF, ΔLL < L/480, TJI-PRO RATING OF 40  
② SHEETROCK CEILING APPLIED TO BOTTOM FACE OF JOISTS



PROJECT NO 0329.2022.01.01  
PROJECT MANAGER WAC  
DRAWN JSD  
ENGINEER BLAKE RASSILYER 206.602.5452  
BLAKER@MALSAM-TSANG.COM

REV	DESCRIPTION	DATE
PERMIT SET		5.27.22
PERMIT CORRECTIONS		1.6.23
POST PERMIT REVISIONS		8.1.23

ARCH JULIAN WEBER ARCH + DESIGN 206.953.1305  
CLIENT COOMBS DEVELOPMENT

**FIRST FLOOR FRAMING PLAN**

**S2.2**  
SCALE - 1/4" = 1'-0"

Revised By: [Signature]  
Printed Date: Aug 01, 2023 - 12:43pm



PROJECT NO 0329.2022.01.01  
PROJECT MANAGER WAC  
DRAWN BY BLAKE RASSILYER JSD  
ENGINEER BLAKE RASSILYER 206.602.5452  
BLAKER@MALSAM-TSANG.COM

REV DESCRIPTION DATE  
PERMIT SET 5.27.22  
PERMIT CORRECTIONS 1.6.23  
POST PERMIT REVISIONS 8.1.23

ARCH JULIAN WEBER ARCH + DESIGN 206.953.1305  
CLIENT COOMBS DEVELOPMENT

**SECOND FLOOR FRAMING PLAN**

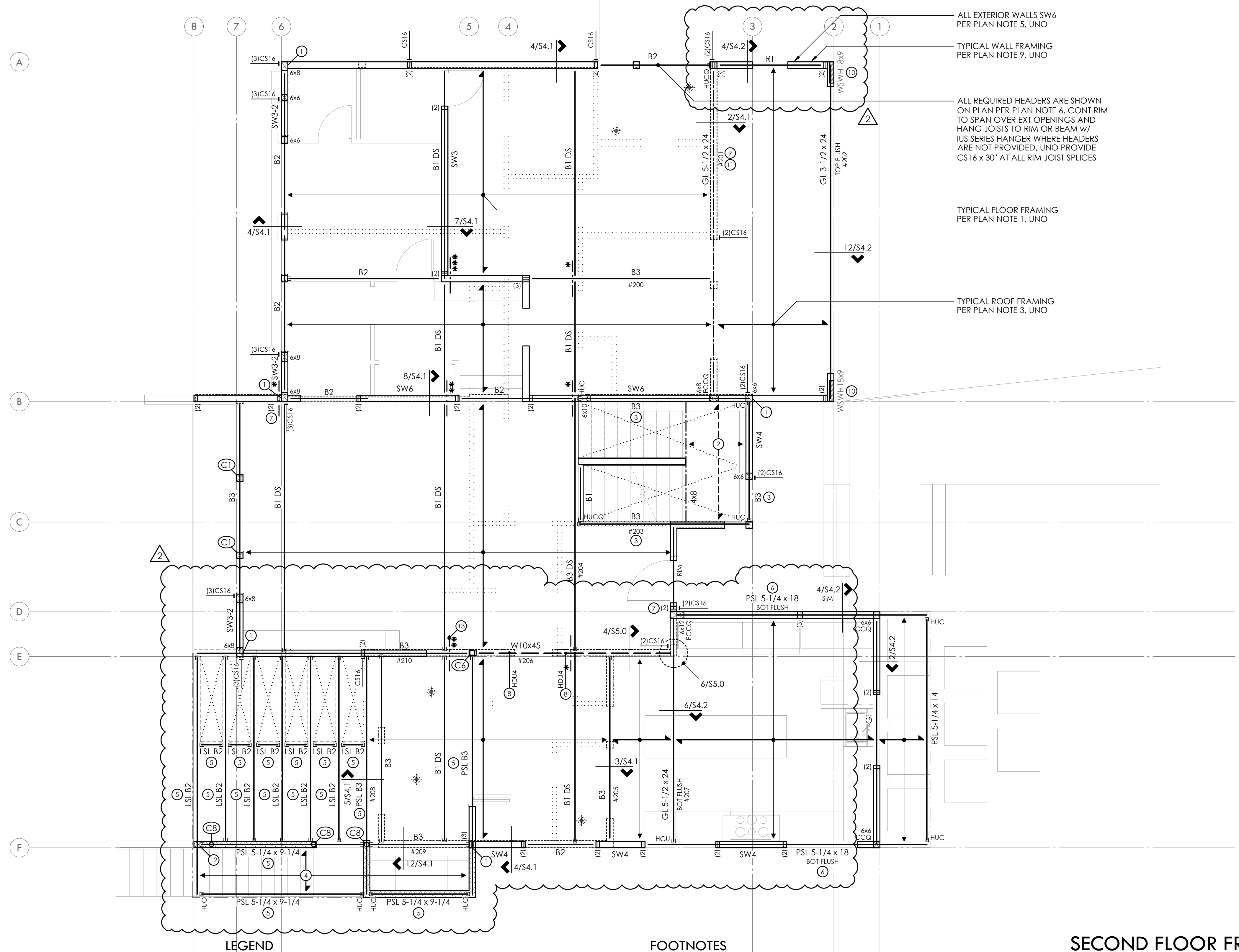

**COLUMN SCHEDULE**

MARK	SIZE	TOP	BOT	AT STEEL
C1	PSL 5-1/4 x 5-1/4	(2)A35	(2)A35	-
C2	PSL 5-1/4 x 5-1/4	ECCQ	A	7/S5.0
C3	PSL 5-1/4 x 7	-	A	-
C4	PSL 5-1/4 x 9-1/4	(2)A35	A	-
C5	PSL 5-1/4 x 9-1/4	-	(2)A35	7/S5.0
C6	HSS 4x4x1/4	10/S5.0	12/S5.0	12/S5.0
C7	HSS 4x4x1/4	-	3/S3.2 & 4/S3.2	12/S5.0
C8	HSS 4Ø x 0.22	3/S5.0	2/S5.0	-
C9	HSS 4Ø x 0.22	3/S5.0	8/S3.2	-

A POST TO BEAR DIRECTLY ON FOUNDATION WALL w/ (2) LAYERS OF BUILDING PAPER AND (2) A35 TO SILL PLATE

**PLAN NOTES**

- TYPICAL FLOOR FRAMING CONSISTS OF 3/4" T&G APA RATED SHEATHING (SPAN RATING 48/24) OVER TJI'S PER JOIST SCHEDULE, UNO. PROVIDE DBL JOISTS UNDER ALL PARALLEL PARTITIONS THAT EXTEND OVER MORE THAN HALF THE JOIST LENGTH.
- GLUE AND NAIL FLOOR SHEATHING w/ 8d AT 6"oc AT FRAMED PANEL EDGES AND OVER SHEARWALLS AND AT 12"oc IN FIELD, UNO.
- TYPICAL ROOF FRAMING CONSISTS OF 3/4" T&G APA RATED SHEATHING (SPAN RATING 48/24) OVER PRE-MANUFACTURED TRUSSES AT 24"oc, UNO. TOP CHORD OF TRUSS TO SLOPE A MIN OF 1/4" PER 1'-0". TRUSSES TO BE A MIN DEPTH OF 14". PROVIDE H2.5A AT EACH END OF ALL TRUSSES, AND H2.5A EACH SIDE OF ALL MULTIPLE TRUSSES, UNO. REFER TO ARCH DRAWINGS FOR TRUSS PROFILE.
- NAIL ROOF SHEATHING w/ 8d AT 6"oc AT FRAMED PANEL EDGES AND OVER SHEARWALLS, AND AT 12"oc IN THE FIELD, UNO.
- "SW" INDICATES SHEARWALL BELOW FRAMING SHOWN. REFER TO SHEARWALL SCHEDULE ON 4/S4.0 FOR ADDITIONAL INFORMATION. ALL EXTERIOR WALLS ARE SW6, UNO.
- ALL REQUIRED HEADERS ARE SHOWN ON PLAN AND SHALL BE (2)X8, UNO. REFER TO DETAIL 8/S4.0 FOR ADDITIONAL REQUIREMENTS.
- PROVIDE (2) BEARING (TRIMMER) STUDS AT EACH END OF ALL HEADERS AND BEAMS 6'-0" IN LENGTH AND OVER, UNO.
- WHERE POSTS OCCUR, PROVIDE SOLID VERTICAL GRAIN BLOCKING THRU FLOOR TO MATCHING SUPPORTS BELOW, UNO.
- TYPICAL WALL FRAMING CONSISTS OF 2x6'S AT 16"oc AT EXTERIOR WALLS AND 2x4'S OR 2x6'S AT 16"oc AT INTERIOR WALLS PER ARCH DRAWINGS, UNO.
- REFER TO SHEET S4.0 FOR TYPICAL WOOD FRAMING DETAILS.
- REFER TO GENERAL STRUCTURAL NOTES SHEET S1.0 FOR ADDITIONAL REQUIREMENTS.
- DO NOT SCALE DRAWINGS. REFER TO ARCH DRAWINGS FOR ALL DIMENSIONS.

**LEGEND**

- STRUCTURAL WALL BELOW
- STRUCTURAL WALL ABOVE
- PARTIAL HEIGHT WALL FRAMED WITH 2x6'S AT 16"oc w/ HGA10KT BOT EACH STUD
- SPAN AND EXTENTS
- HEADER/BEAM BELOW FRAMING - TYP
- NUMBER OF BUILT UP STUDS
- PLUMBING PENETRATION ABOVE
- HORIZ CS16 x 3'-0" - BEAM TO BEAM
- (2) HORIZ CS16 x 3'-0" - BEAM TO BEAM
- (3) HORIZ CS16 x 3'-0" - BEAM TO BEAM
- DRAG STRUT - NAIL THRU SHEATHING w/ 8d AT 4"oc INTO ENTIRE LENGTH OF MEMBER
- GIRDER TRUSS

**FOOTNOTES**

- SHEARWALL SHEATHING CONTINUOUS THRU WALL INTERSECTION
- LANDING FRAMING CONSISTS OF 2x8'S AT 16"oc w/ LUS HANGER TO 2X LEDGER w/ (2) 0.22"Ø x 6" SDWS TIMBER SCREWS AT 16"oc INTO EA STUD
- PROVIDE 0.22"Ø x 6" SDWS TIMBER SCREWS AT 16"oc THRU DOUBLE TOP PLATE INTO BEAM
- TYPICAL ROOF FRAMING CONSISTS OF 3/4" T&G APA RATED SHEATHING (SPAN RATING 48/24) OVER 2x12'S AT 24"oc, UNO. RAFTERS CAN BE TAPERED TO A MIN DEPTH OF 8"
- NOTCH AND TAPER BEAM TO MATCH JOIST DEPTH - 8" MIN, NO OVERCUTS
- NOTCH AND TAPER BEAM TO MATCH JOIST DEPTH - 14" MIN, NO OVERCUTS
- PROVIDE 0.22"Ø x 6" SDWS TIMBER SCREWS AT 12"oc THRU DOUBLE STUDS INTO POST (6 TOTAL)
- PROVIDE ALL-THREAD TO MATCH AB SIZE IN HOLDOWN SCHEDULE - WELD TO TOP OF STEEL BEAM PER DETAIL 1/S5.0
- BEAM BOTTOM FLUSH WITH ROOF FRAMING
- FIELD TRIM SIMPSON STRONG WALL HIGH STRENGTH WOOD SHEARWALL AS REQUIRED AND CONNECT TO BEAM w/ WSWH-TP AND WSWH-PS PER MANUFACTURER'S REQUIREMENTS AND IN ACCORDANCE w/ ESR-2652 - REFER DETAIL 10/S4.1
- INSTALL 2x PLATES w/ 10d AT 4"oc FOR ENTIRE LENGTH OF BEAM AS REQUIRED
- INSTALL HUC/HANGER UPSIDE DOWN
- INSTALL STRAPS TO TOP AND UNDERSIDE OF DRAG STRUTS

**SECOND FLOOR FRAMING PLAN**

SECOND FLOOR WALLS SHOWN DASHED  
FIRST FLOOR WALLS SHOWN SOLID

**FLUSH BEAM SCHEDULE**

MARK	SIZE	BRG STUDS	HANGER
B1	LSL 1-3/4 x 11-7/8	2	HUS1.81/10
B2	GL 3-1/2 x 11-7/8 OR LSL 3-1/2 x 11-7/8	2	HHUS410 HHUS410
B3	GL 5-1/2 x 11-7/8 OR PSL 5-1/4 x 11-7/8	3	HGUS5.50/10 HGUS5.50/10
B4	PSL 7 x 11-7/8	4	HGUS7.25/10

- 1 ALL GLULAM BEAMS ARE 24F-V4 - UNO
- 2 PROVIDE HUC410 WHERE REQUIRED - UNO

**JOIST SCHEDULE**

MAX LENGTH	SIZE	SPACING	FACE MOUNT HANGER	TOP FLANGE HANGER
18'-0"	11-7/8" TJI 110	16"oc	IUS1.81/11.88	ITS1.81/11.88
18'-9"	11-7/8" TJI 210	16"oc	IUS2.06/11.88	ITS2.06/11.88
19'-3"	11-7/8" TJI 230	16"oc	IUS2.37/11.88	ITS2.37/11.88
20'-0"	11-7/8" TJI 360	16"oc	IUS2.37/11.88	ITS2.37/11.88
22'-0"	11-7/8" TJI 560	16"oc	IUS3.56/11.88	ITS3.56/11.88

- 1 DESIGN BASED ON DL=15 PSF, LL=40 PSF, ΔLL < L/480, TJI-PRO RATING OF 40
- 2 SHEETROCK CEILING APPLIED TO BOTTOM FACE OF JOISTS

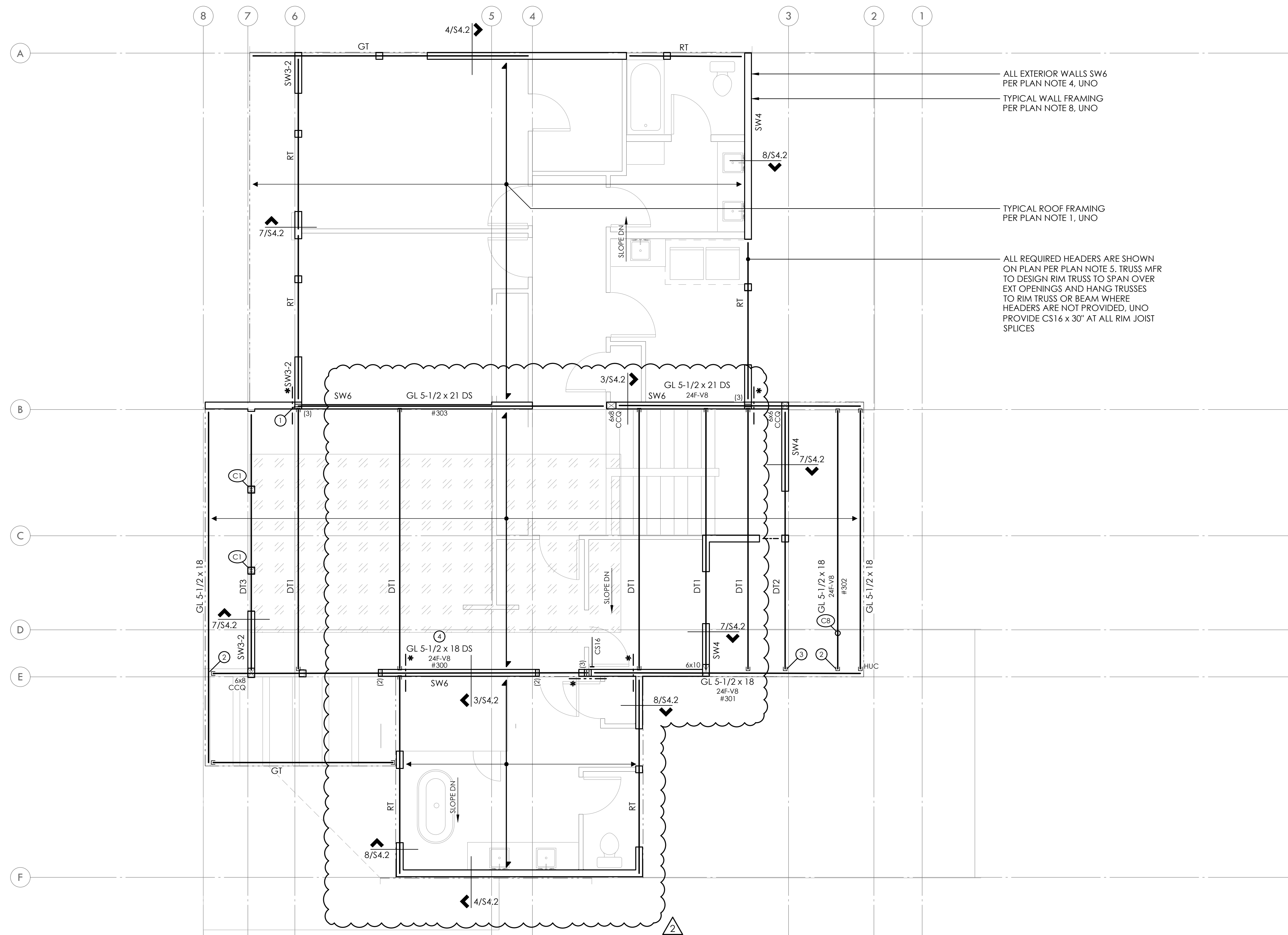

**PLAN NOTES**

- TYPICAL ROOF FRAMING CONSISTS OF 3/4" T&G APA RATED SHEATHING (SPAN RATING 48/24) OVER PRE-MANUFACTURED TRUSSES AT 24"oc, UNO. TOP CHORD OF TRUSS TO SLOPE A MIN OF 1/4" PER 1'-0". TRUSSES TO BE A MIN DEPTH OF 14". PROVIDE H2.5A AT EACH END OF ALL TRUSSES, AND H2.5A EACH SIDE OF ALL MULTIPLE TRUSSES, UNO. REFER TO ARCH DRAWINGS FOR TRUSS PROFILE.
- TYPICAL CRICKET ROOF FRAMING CONSISTS OF 3/4" T&G APA RATED SHEATHING (SPAN RATING 48/24) OVER 2x SLEEPERS AT 24"oc. TOENAIL SLEEPERS w/ (2) 10d AT 24"oc OVER TYPICAL ROOF FRAMING. PROVIDE VENTING HOLES BELOW CRICKET ROOF FRAMING AS REQUIRED.
- NAIL ROOF SHEATHING w/ 8d AT 6" oc AT FRAMED PANEL EDGES AND OVER SHEARWALLS, AND AT 12"oc IN FIELD, UNO.
- "SW\_" INDICATES SHEARWALL BELOW FRAMING SHOWN. REFER TO SHEARWALL SCHEDULE ON 4/S4.0 FOR ADDITIONAL INFORMATION. ALL EXTERIOR WALLS ARE SW6, UNO.
- ALL REQUIRED HEADERS ARE SHOWN ON PLAN AND SHALL BE (2)2x8, UNO. REFER TO DETAIL 8/S4.0 FOR ADDITIONAL REQUIREMENTS.
- PROVIDE (2) BEARING (TRIMMER) STUDS AT EACH END OF ALL HEADERS, BEAMS, AND GIRDER TRUSSES 6'-0" IN LENGTH AND OVER, UNO.
- WHERE POSTS OCCUR, PROVIDE SOLID VERTICAL GRAIN BLOCKING THRU FLOOR TO MATCHING SUPPORTS BELOW, UNO.
- TYPICAL WALL FRAMING CONSISTS OF 2x6's AT 16"oc AT EXTERIOR WALLS AND 2x4's or 2x6's AT 16"oc AT INTERIOR WALLS PER ARCH DRAWINGS, UNO.
- REFER TO SHEET S4.0 FOR TYPICAL WOOD FRAMING DETAILS.
- REFER TO GENERAL STRUCTURAL NOTES SHEET S1.0 FOR ADDITIONAL REQUIREMENTS.
- DO NOT SCALE DRAWINGS. REFER TO ARCH DRAWINGS FOR ALL DIMENSIONS.

**LEGEND**

- STRUCTURAL WALL BELOW
- SPAN AND EXTENTS
- HEADER/BEAM BELOW FRAMING - TYP
- SLOPE DN DIRECTION OF SLOPE
- (x) NUMBER OF BUILT UP STUDS
- \* --- HORIZ CS16 x 3'-0" - TRUSS TO TRUSS/TOP PLATE TO TOP PLATE
- DS DRAG STRUT - NAIL THRU SHEATHING w/ 8d AT 4"oc INTO ENTIRE LENGTH OF MEMBER
- DT DRAG TRUSS - NAIL THRU SHEATHING w/ 8d AT 4"oc INTO ENTIRE LENGTH OF TRUSS
- GT GIRDER TRUSS
- RT RIM TRUSS

**FOOTNOTES**

- SHEARWALL SHEATHING CONTINUOUS THRU WALL INTERSECTION
- INSTALL HUCQ HANGER UPSIDE DOWN
- HANGER PER TRUSS MANUFACTURER
- INSTALL 2x PLATES w/ 10d AT 4"oc FOR ENTIRE LENGTH OF BEAM AS REQUIRED TO FLUSH UNDERSIDE OF ROOF SHEATHING

**DRAG TRUSS SCHEDULE**

MARK	LOAD TRANSFER ①②
DT1	1.0 KIPS
DT2	1.5 KIPS
DT3	2.0 KIPS

- TRUSS MFR TO DESIGN TRUSS TO TRANSFER LISTED LOAD FROM TOP TO BOT CHORD
- NAIL THRU SHEATHING w/ 8d AT 4"oc INTO ENTIRE LENGTH OF MEMBER

**ROOF FRAMING PLAN**

SECOND FLOOR WALLS SHOWN SOLID

**COLUMN SCHEDULE**

MARK	SIZE	TOP	BOT	AT STEEL
C1	PSL 5-1/4 x 5-1/4	(2)A35	(2)A35	-
C2	PSL 5-1/4 x 5-1/4	ECCQ	Ⓐ	-
C3	PSL 5-1/4 x 7	-	Ⓐ	7/S5.0
C4	PSL 5-1/4 x 9-1/4	(2)A35	Ⓐ	-
C5	PSL 5-1/4 x 9-1/4	(2)A35	(2)A35	7/S5.0
C6	HSS 4x4x1/4	10/S5.0	12/S5.0	12/S5.0
C7	HSS 4x4x1/4	-	3/S3.2 & 4/S3.2	12/S5.0
C8	HSS 4Ø x 0.22	3/S5.0	2/S5.0	-
C9	HSS 4Ø x 0.22	3/S5.0	8/S3.2	-

- POST TO BEAR DIRECTLY ON FOUNDATION WALL w/ (2)LAYERS OF BUILDING PAPER AND (2)A35 TO SILL PLATE

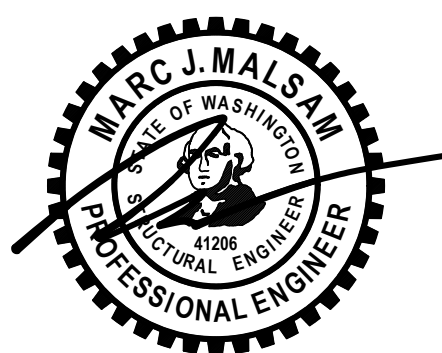

PROJECT NO 0329.2022.01.01  
PROJECT MANAGER WAC  
DRAWN BY BLAKE RASSILYER JSD  
ENGINEER BLAKE RASSILYER 206.602.5452  
BLAKER@MALSAM-TSANG.COM

REV	DESCRIPTION	DATE
1	PERMIT SET	5.27.22
2	PERMIT CORRECTIONS	1.6.23
3	POST PERMIT REVISIONS	8.1.23

ARCH JULIAN WEBER ARCH + DESIGN  
206.953.1305  
CLIENT COOMBS DEVELOPMENT

**ROOF FRAMING PLAN**



COPYRIGHT © 2020 MALSAM TSANG ENGINEERING CORPORATION - ALL RIGHTS RESERVED

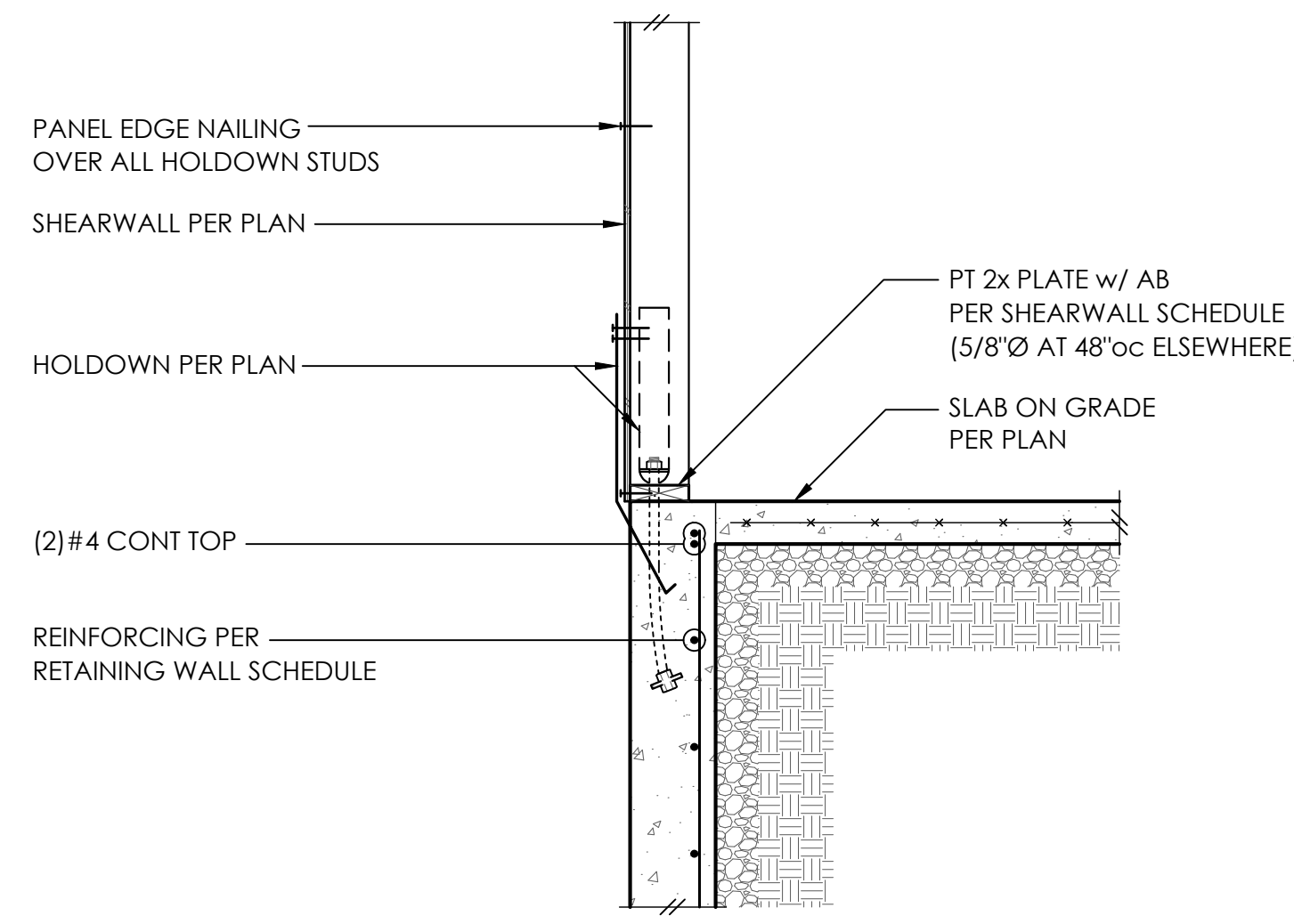

1

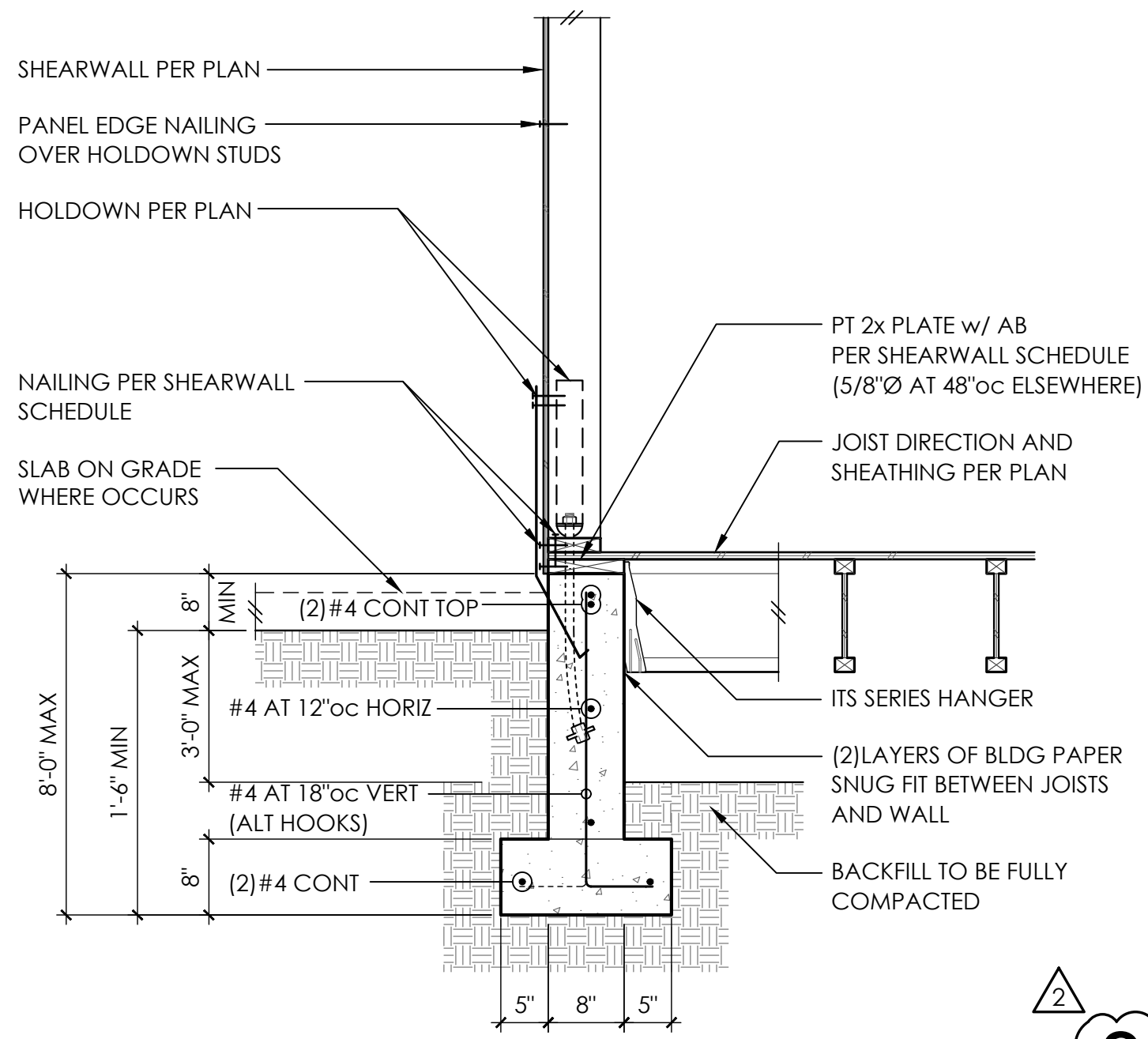

2

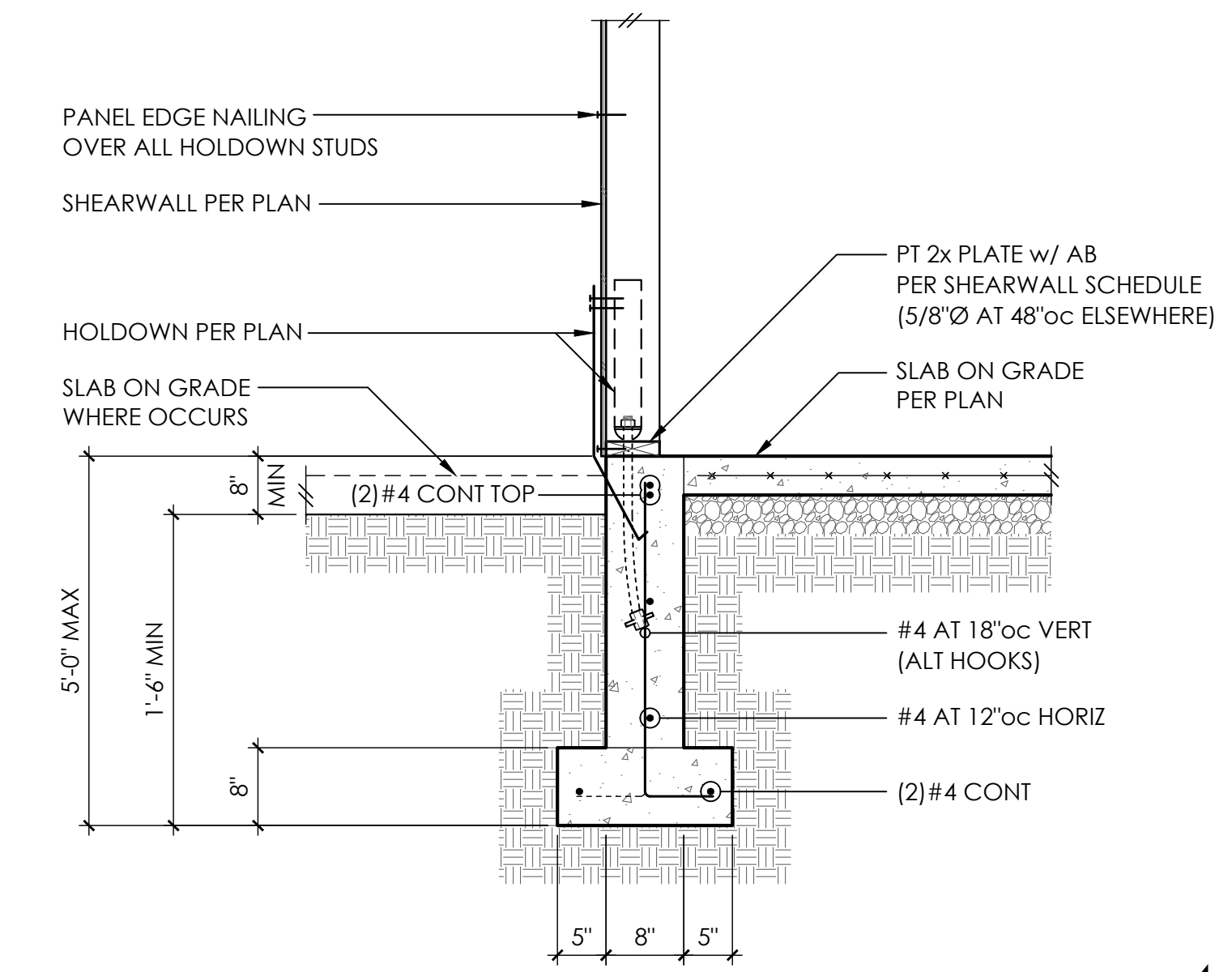

3

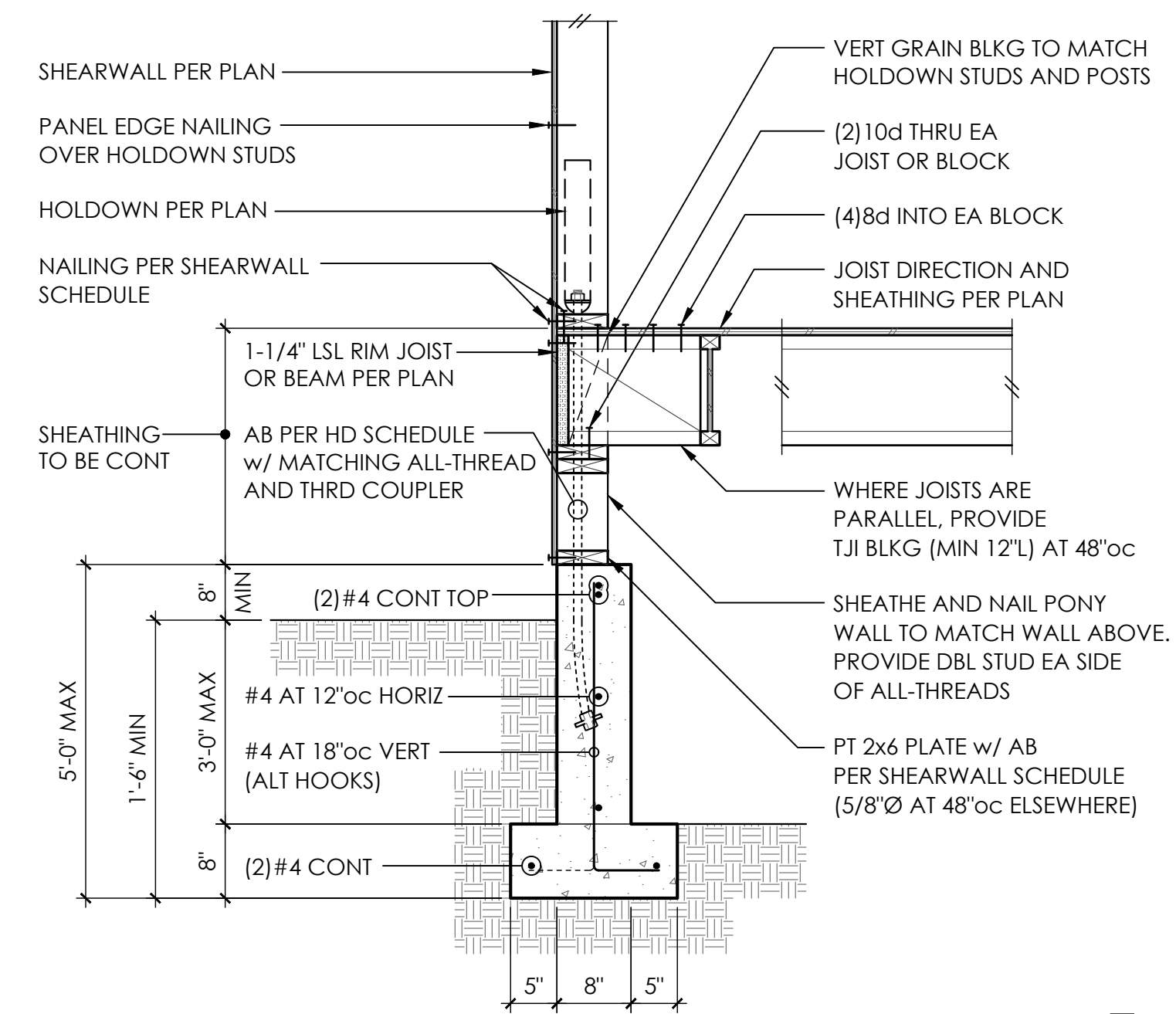

4

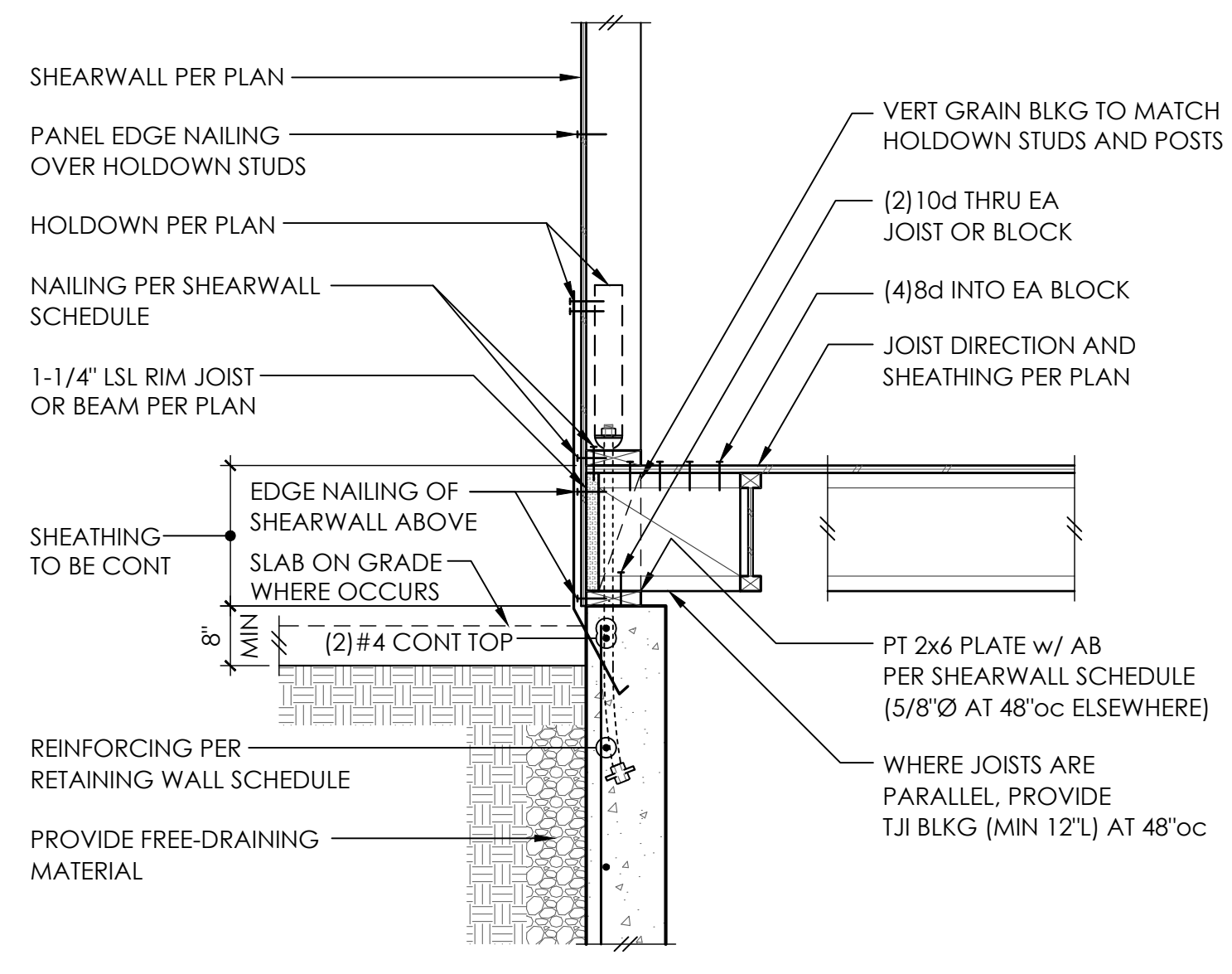

5

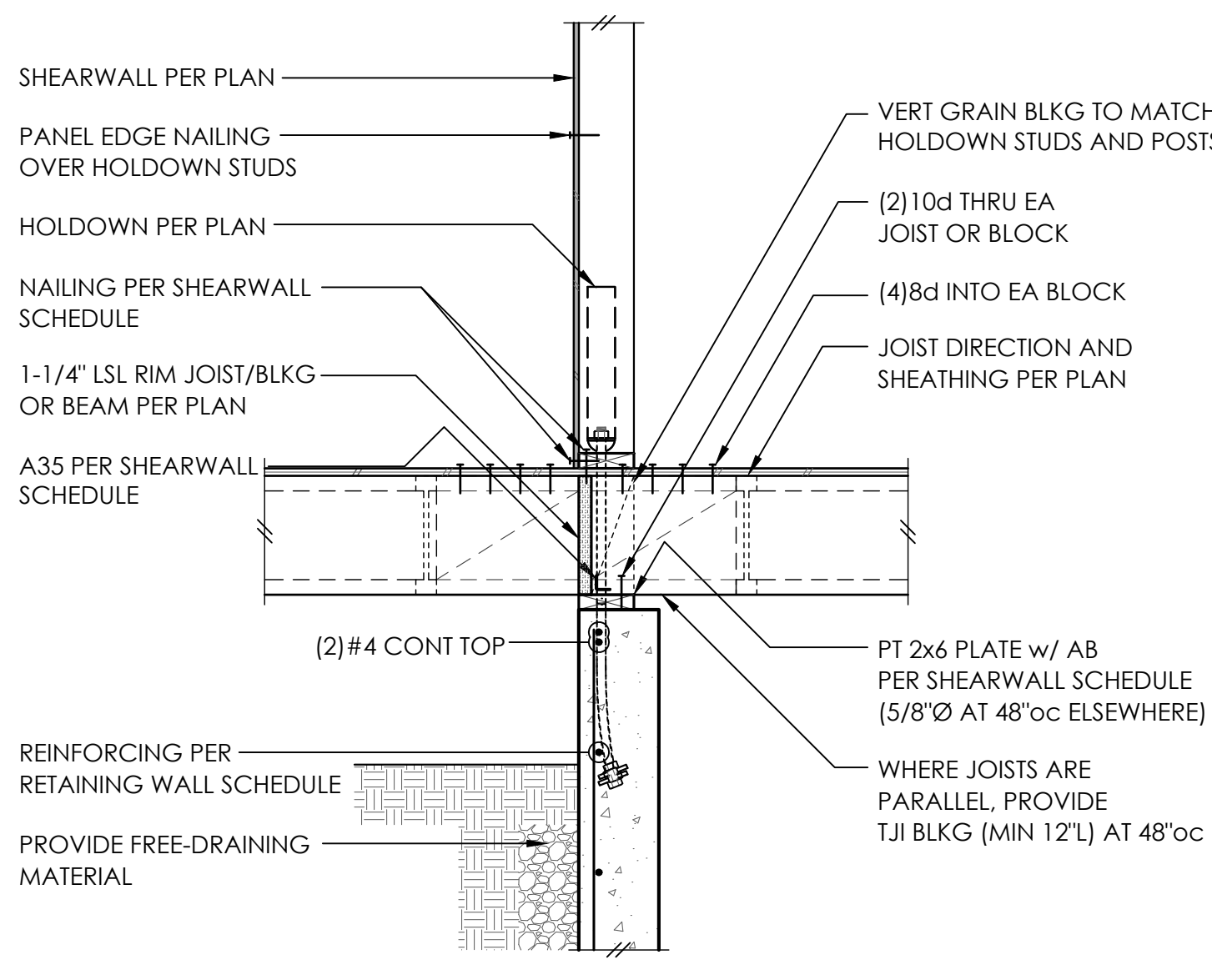

6

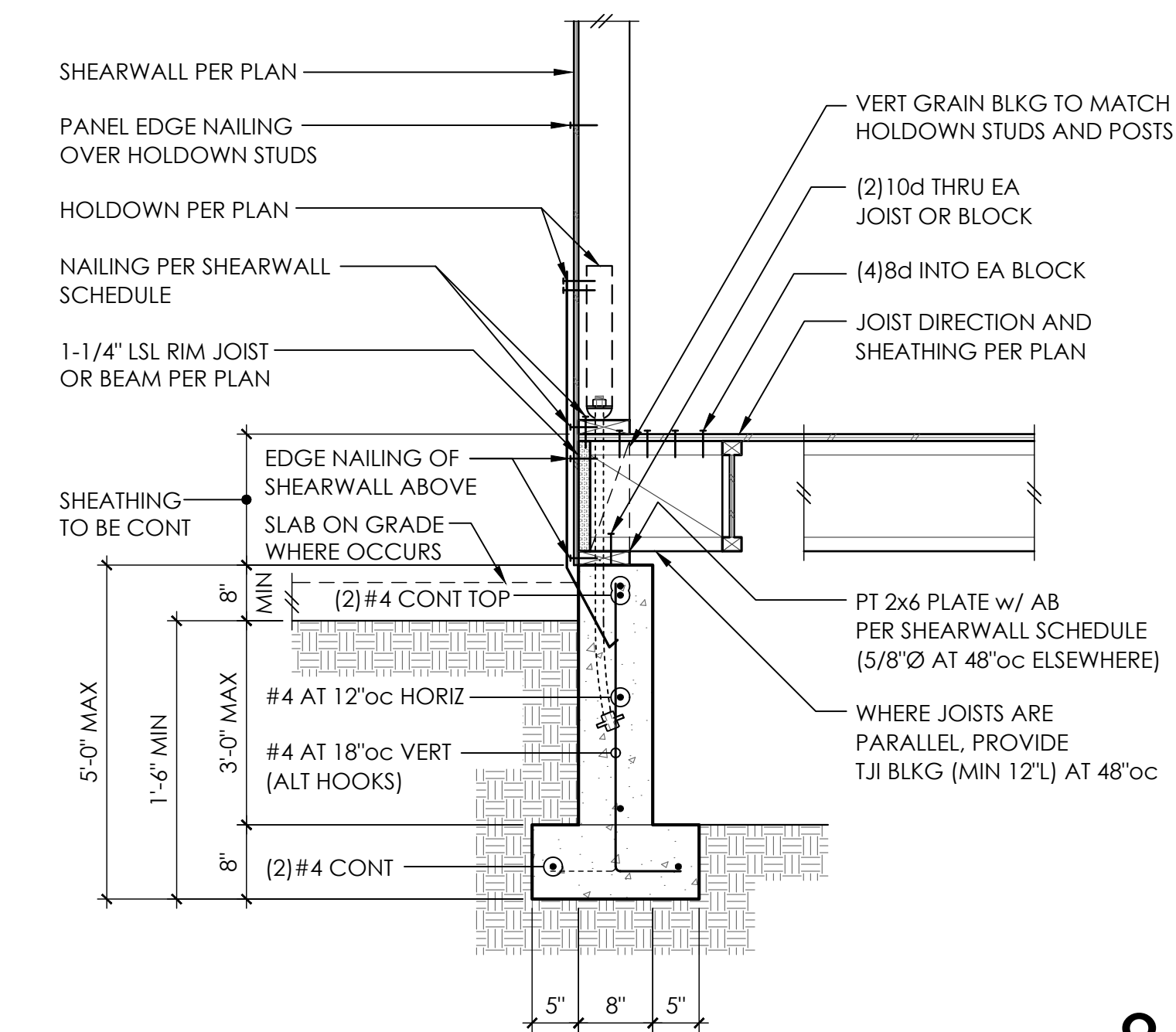

7

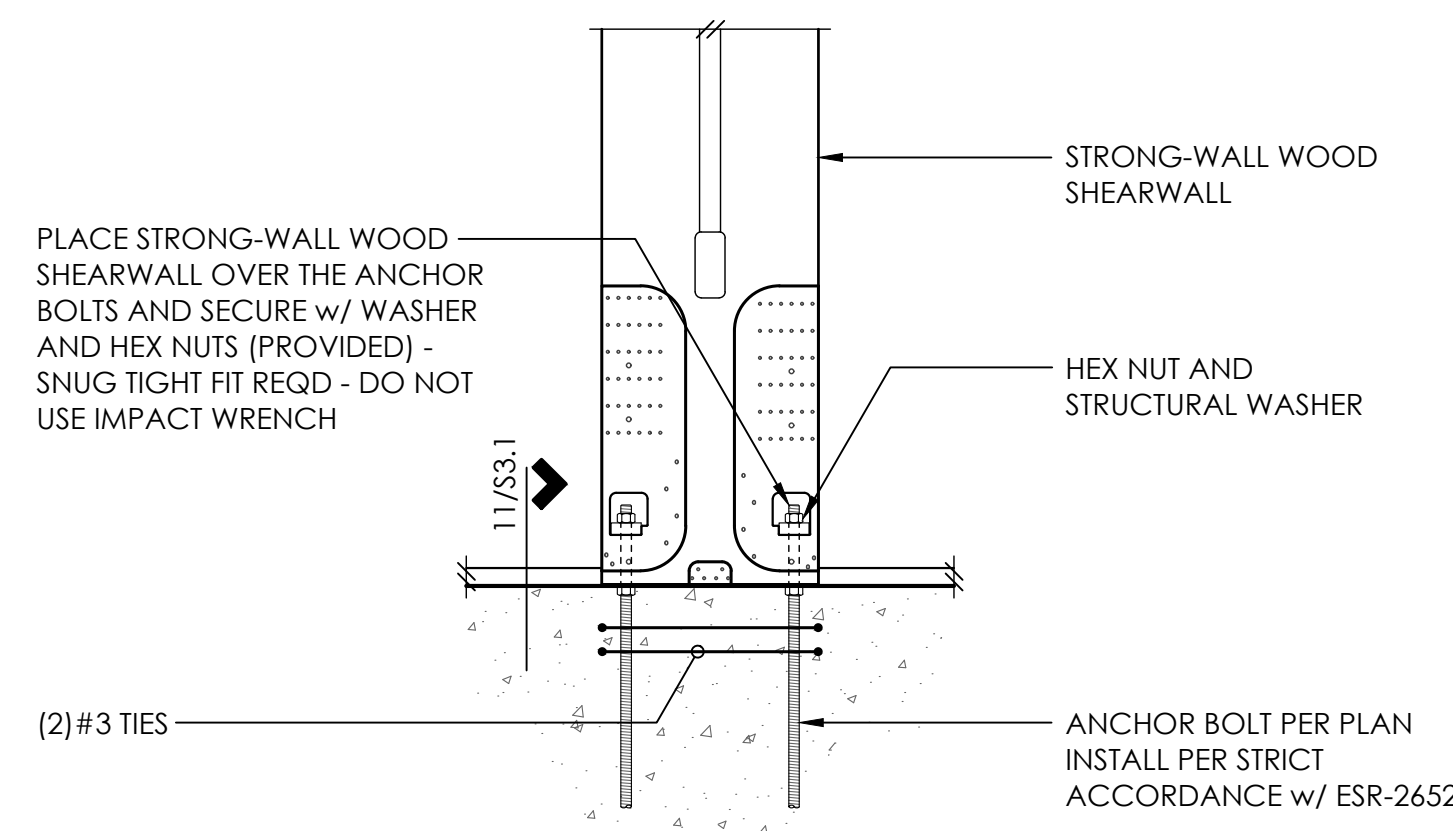

8

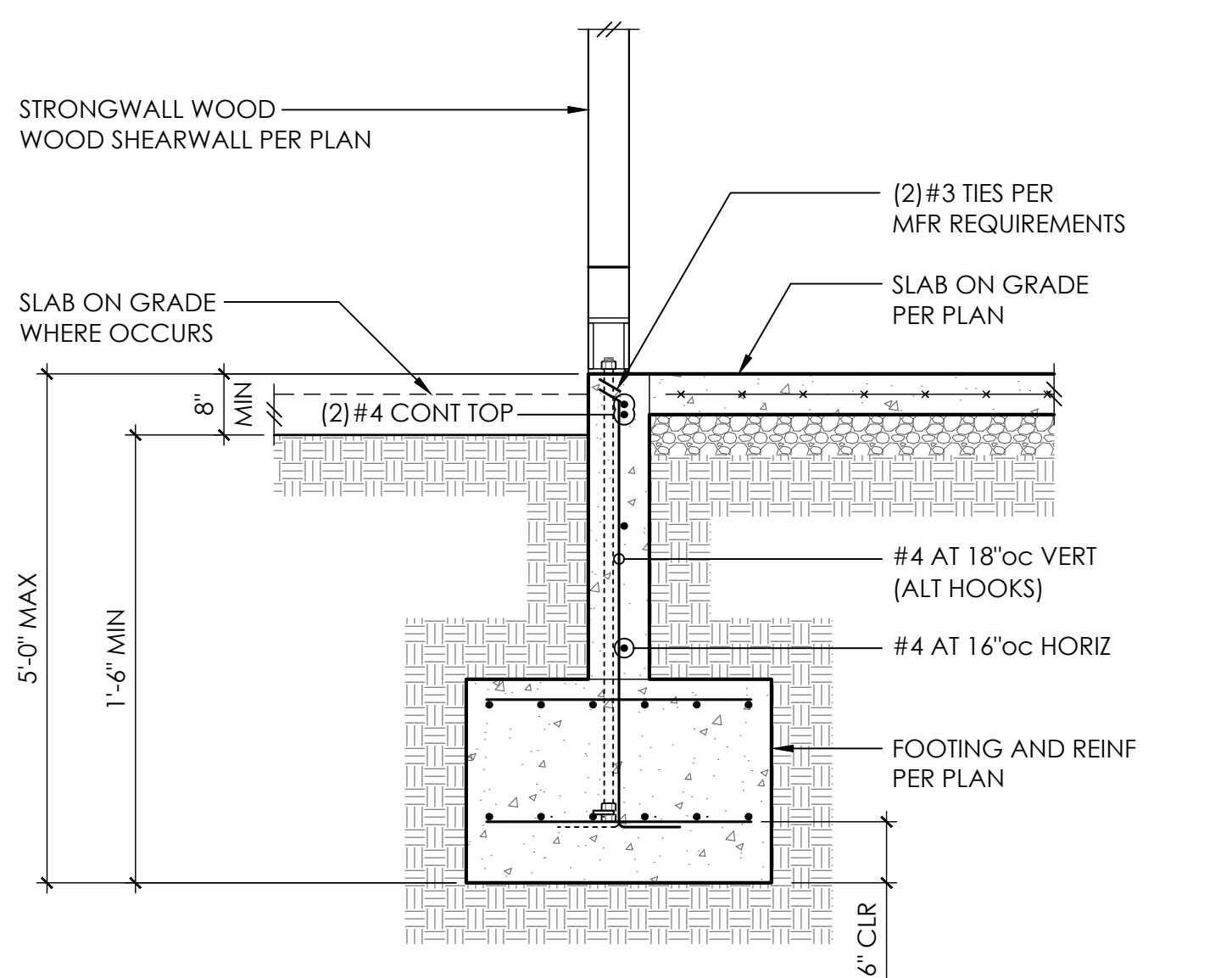

9

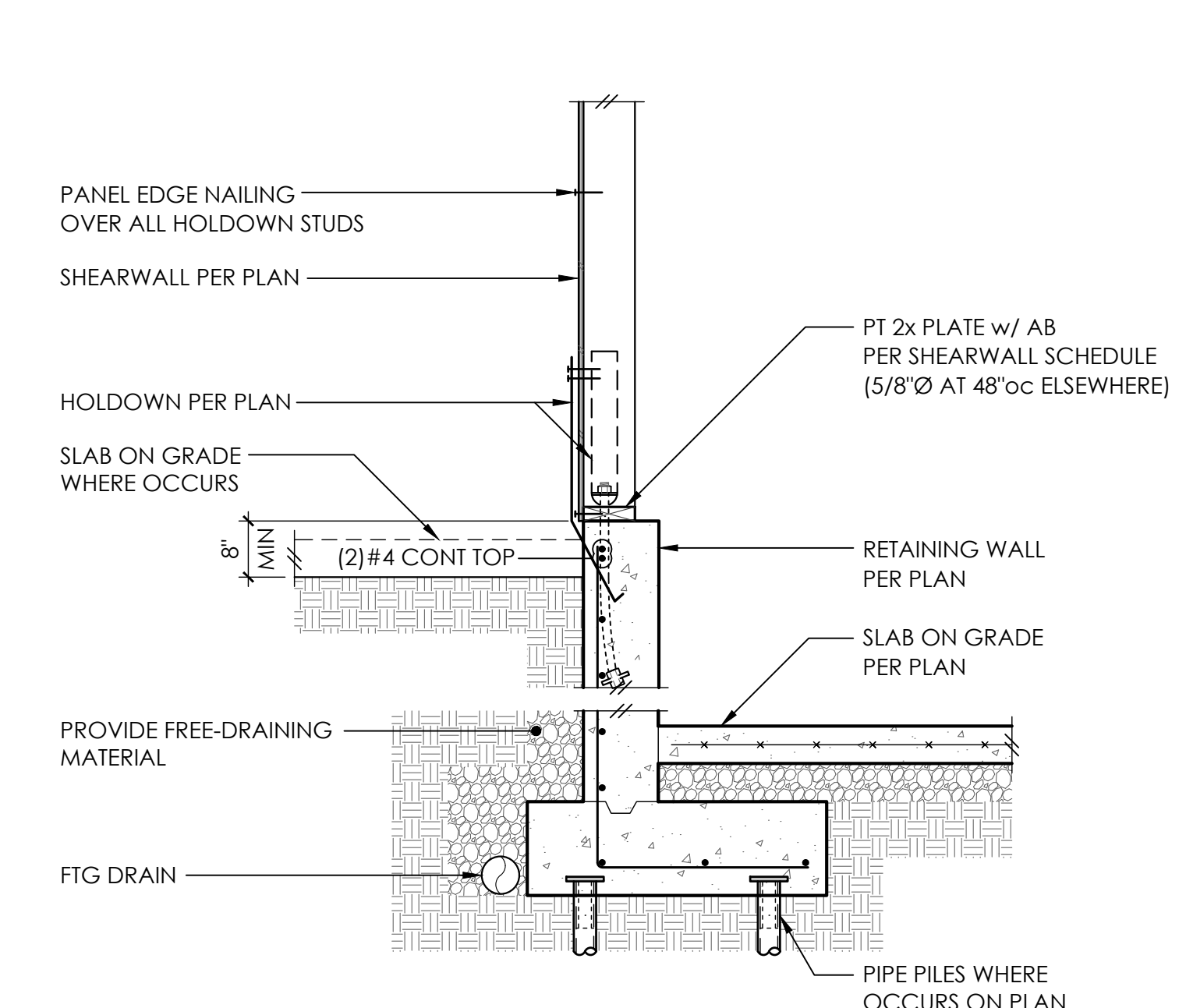

10

Revised by: [unclear]  
Printed on: Aug 01, 2023 - 12:43pm

CONTRACTOR TO REFER TO SIMPSON STRONG WALL SHOP DRAWINGS AND PRODUCT INSTALLATION GUIDELINES TO ENSURE INSTALLATION CONFORMANCE

CONTRACTOR TO REFER TO SIMPSON STRONG WALL SHOP DRAWINGS AND PRODUCT INSTALLATION GUIDELINES TO ENSURE INSTALLATION CONFORMANCE

INSTALL SIMPSON STRONGWALL AND ANCHORAGE IN STRICT ACCORDANCE w/ ESR-2652

CONCRETE DETAILS



PROJECT NO	0329.2022.01.01	
PROJECT MANAGER	WAC	
DRAWN	JSD	
ENGINEER	BLAKE RASSILYER	
	206.602.5452	
	BLAKER@MALSAM-TSANG.COM	
REV	DESCRIPTION	DATE
	PERMIT SET	5.27.22
△	PERMIT CORRECTIONS	1.6.23
△	POST PERMIT REVISIONS	8.1.23

ARCH JULIAN WEBER ARCH + DESIGN  
206.953.1305  
CLIENT COOMBS DEVELOPMENT

**CONCRETE DETAILS**

**S3.2**  
SCALE - 3/4" = 1'-0"

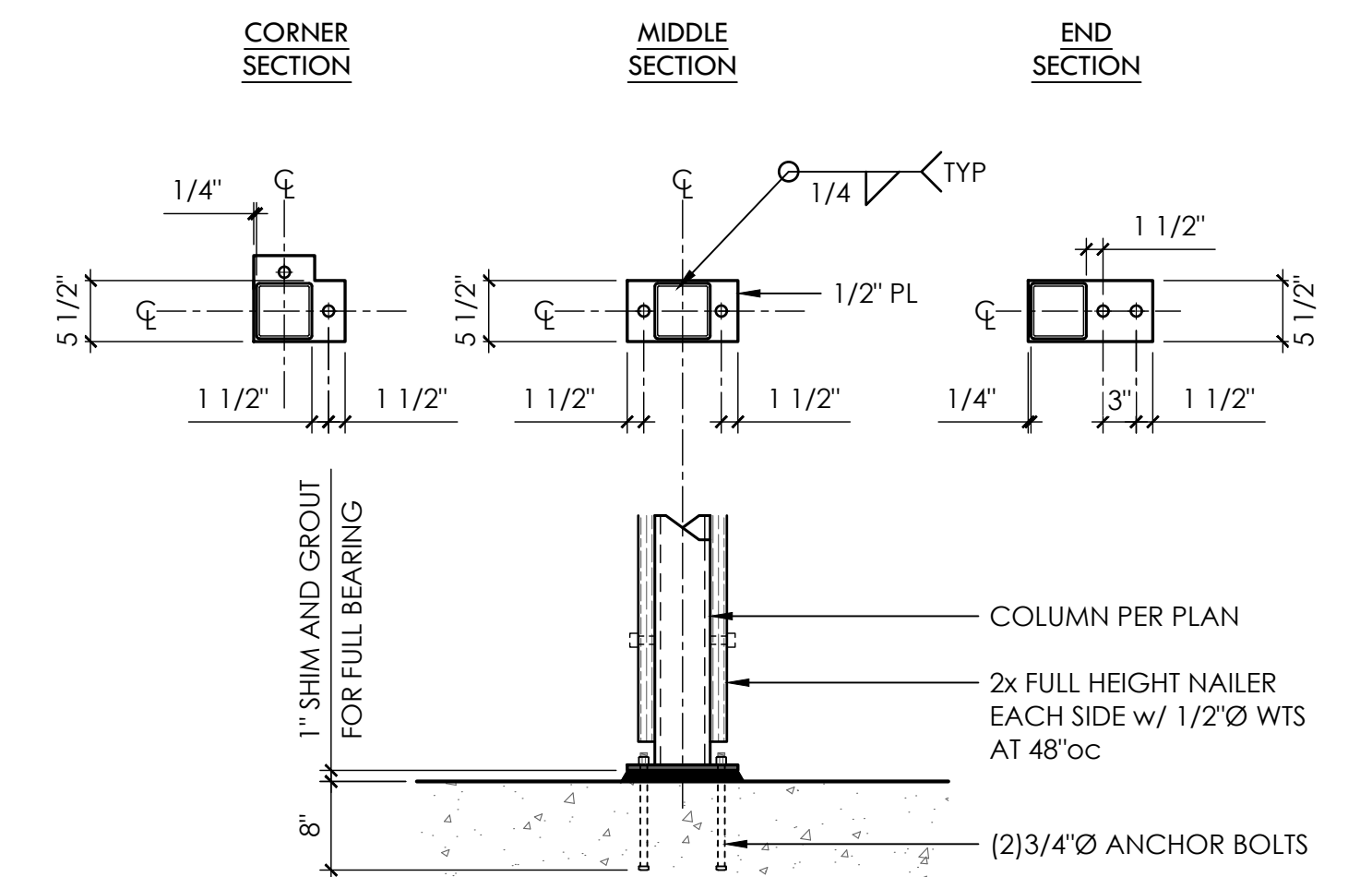

**BASEPLATE - HSS COLUMN**

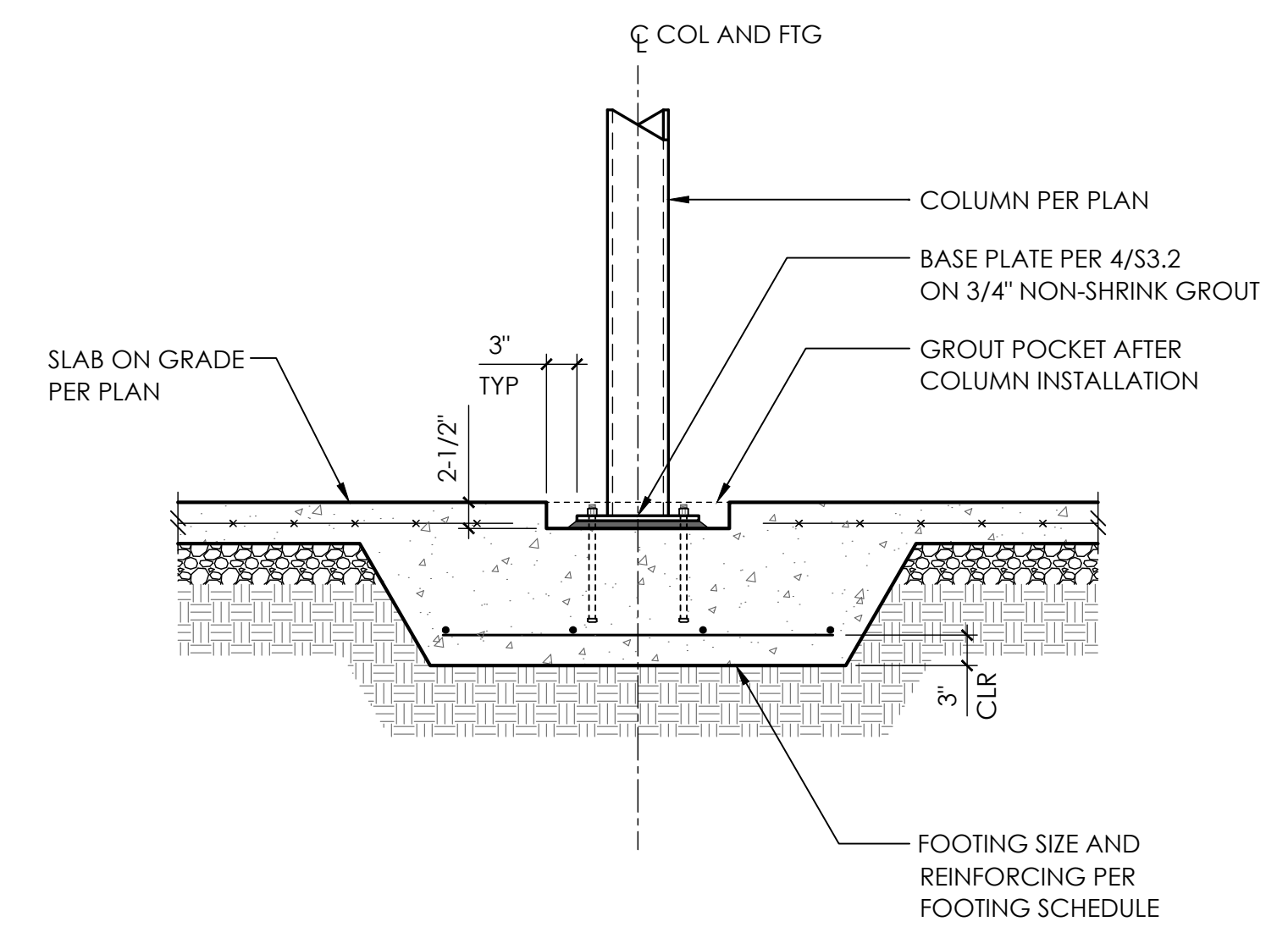

**3**

**2**

**1**

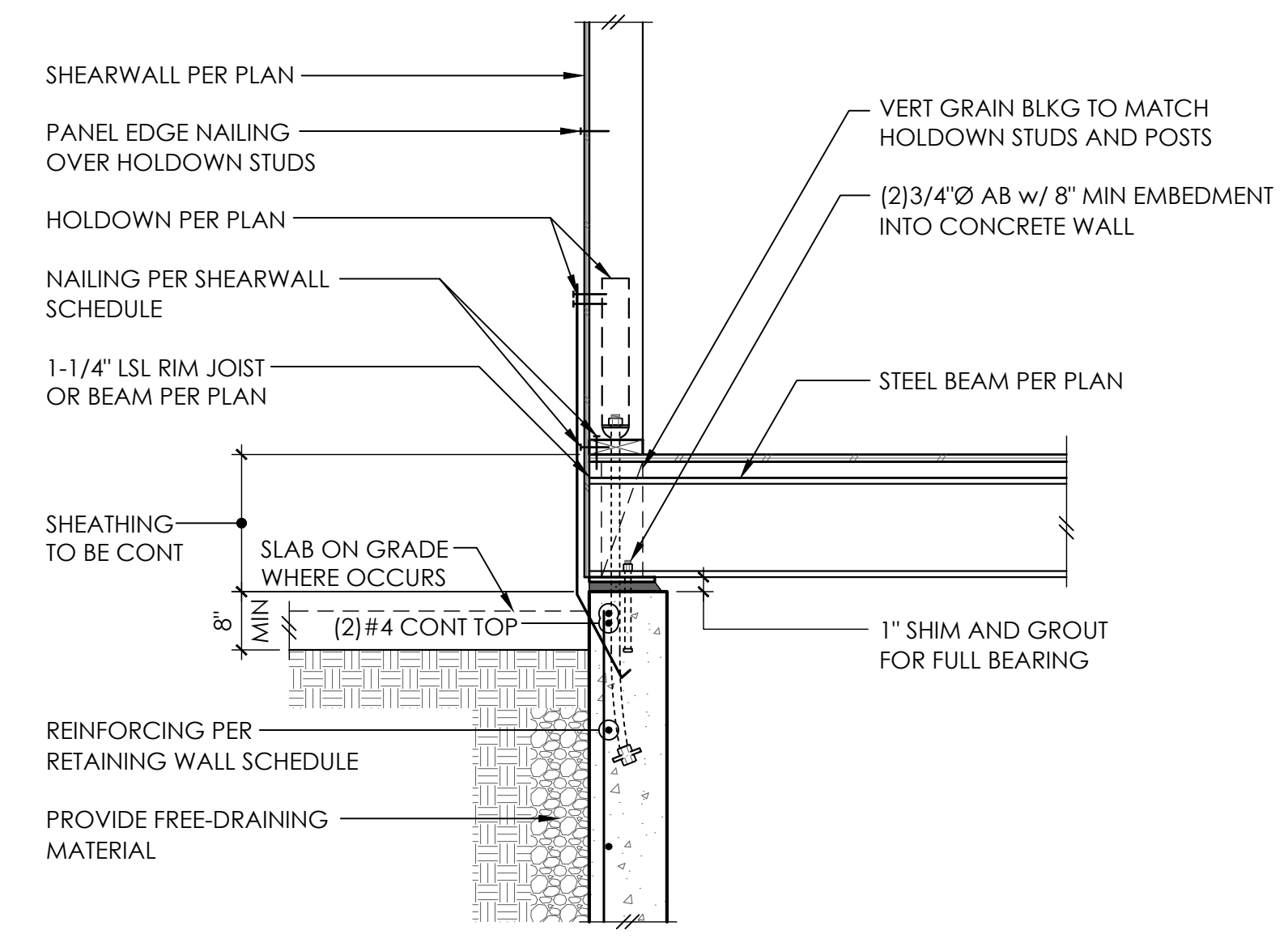

**7**

**6**

**5**

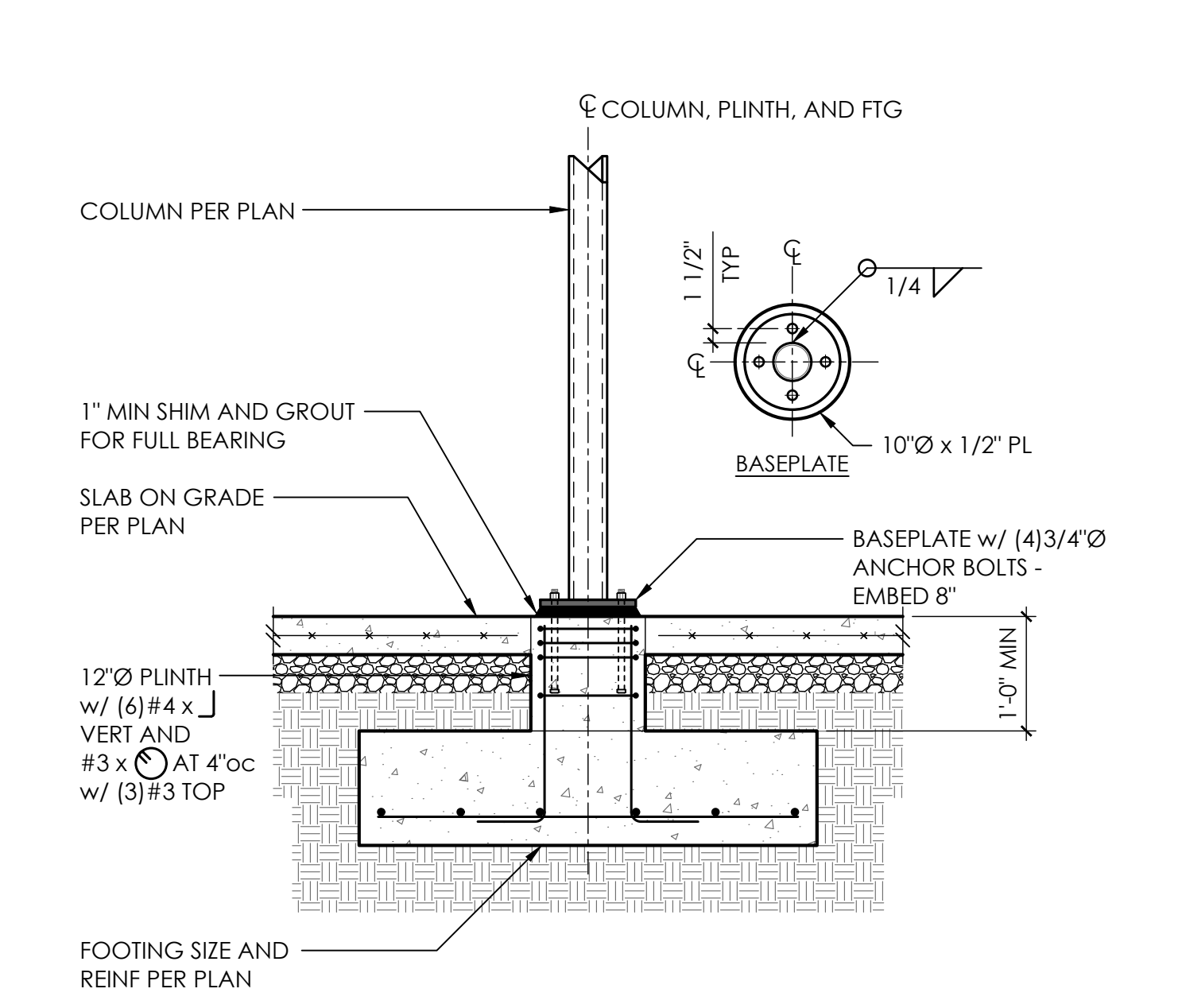

**8**

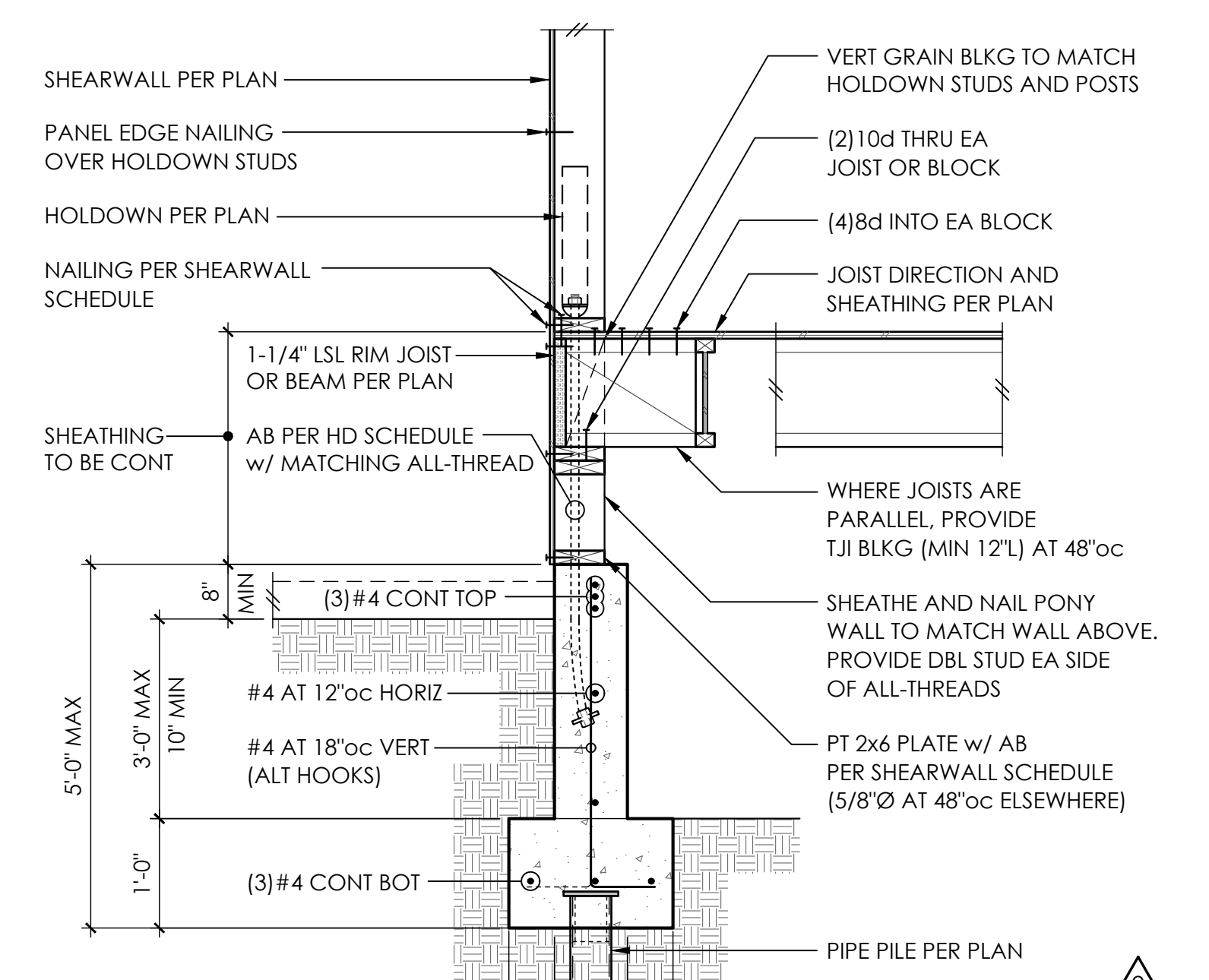

**11**

**10**

**9**

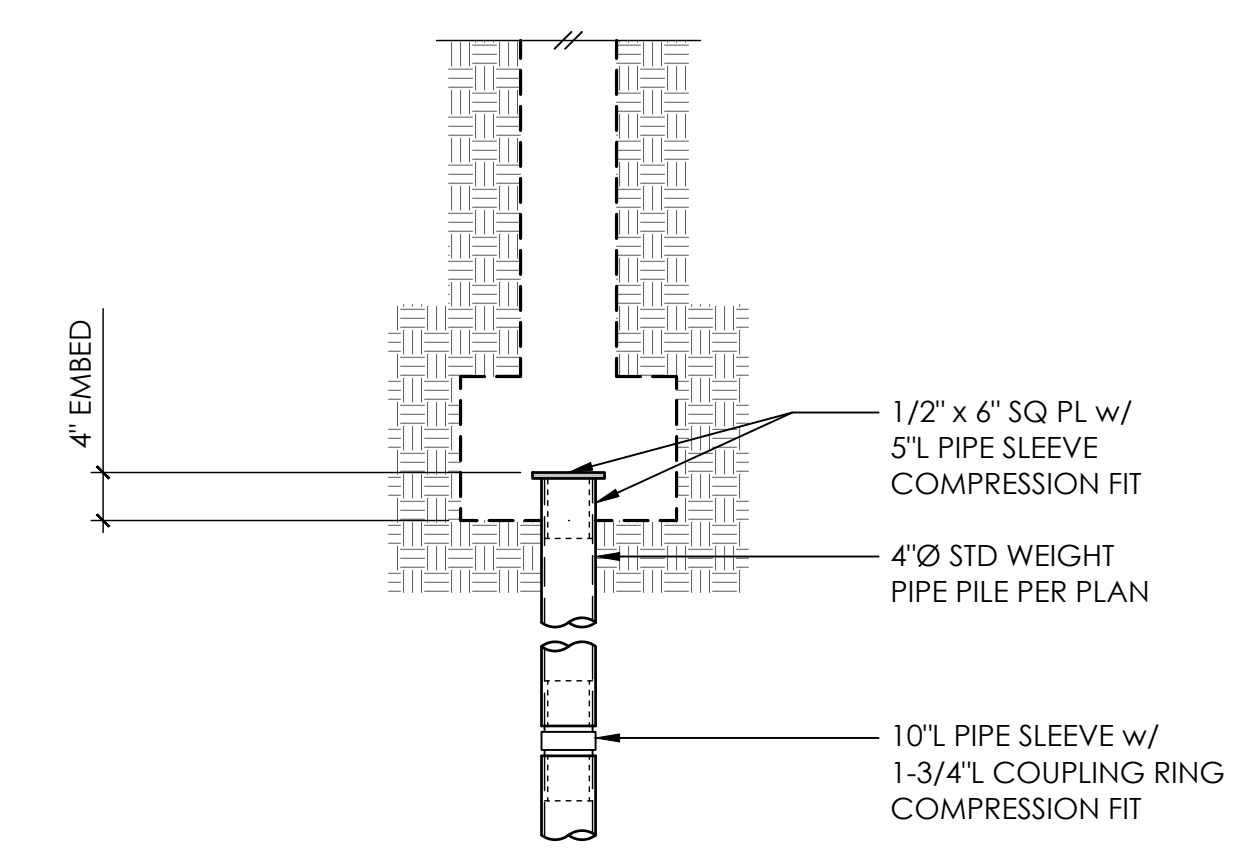

**4" Ø PILES  
TYPICAL PIPE PILE**

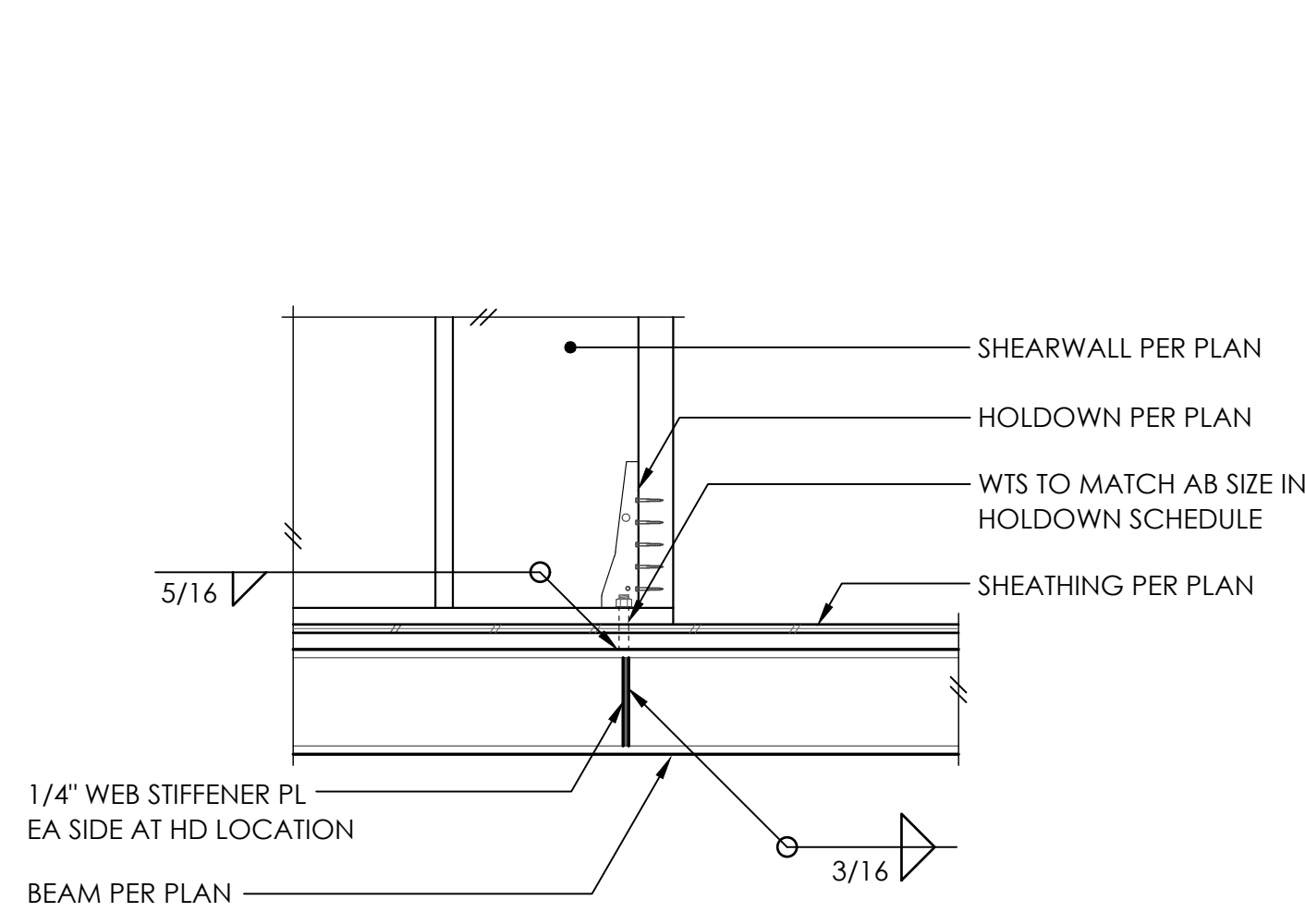

1

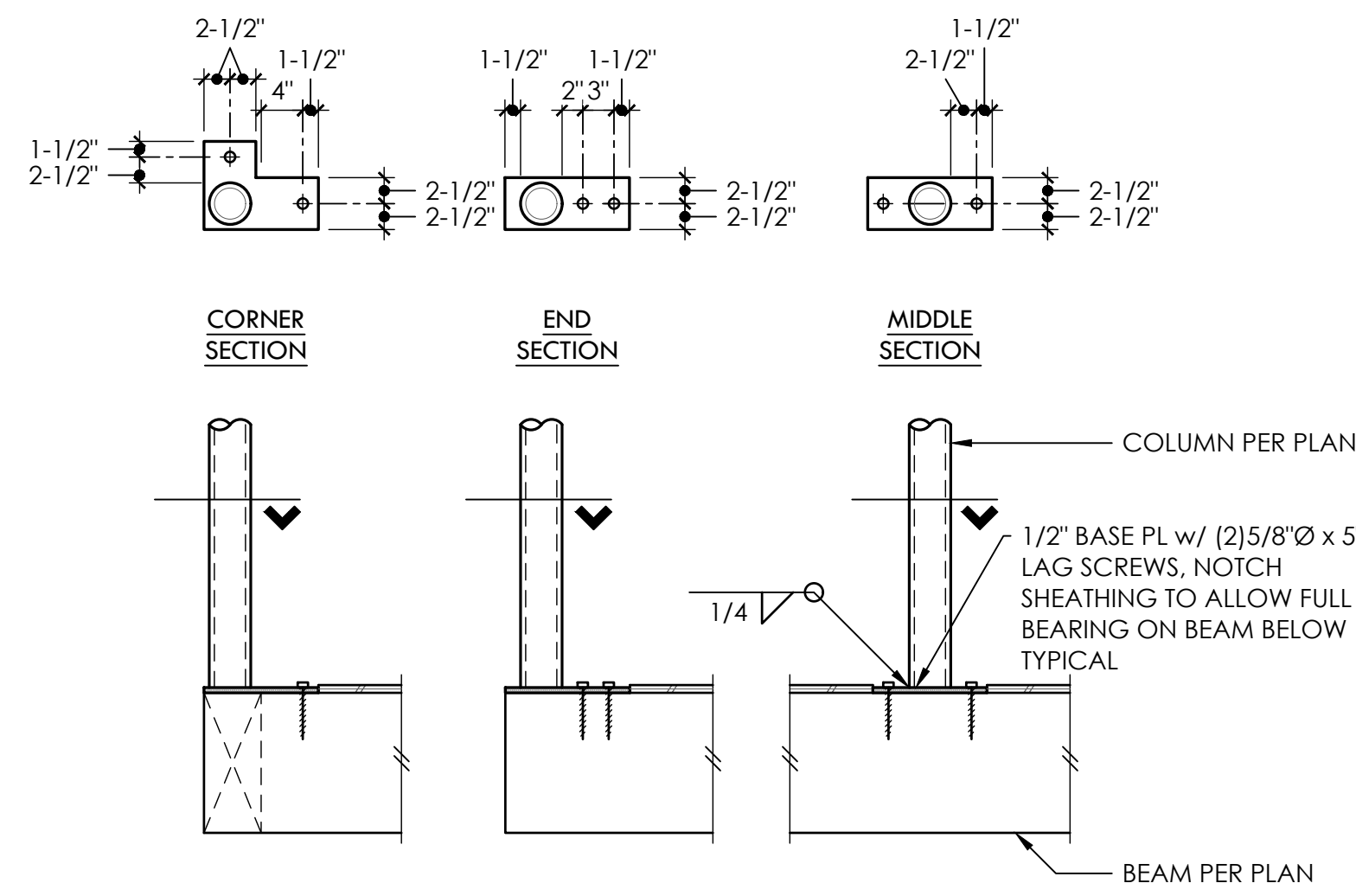

TYPICAL STEEL COLUMN TO WOOD BEAM BELOW

2

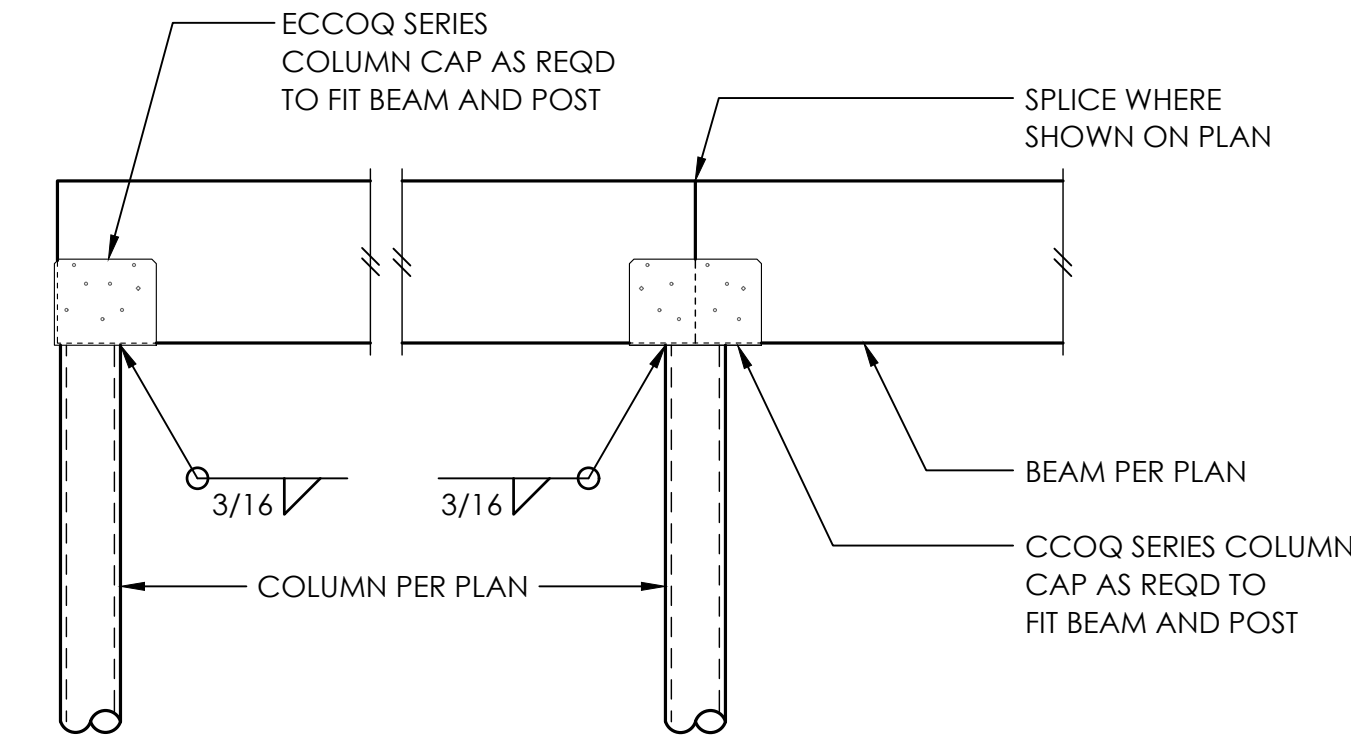

TYPICAL CCOQ / ECCOQ COLUMN CAP

3

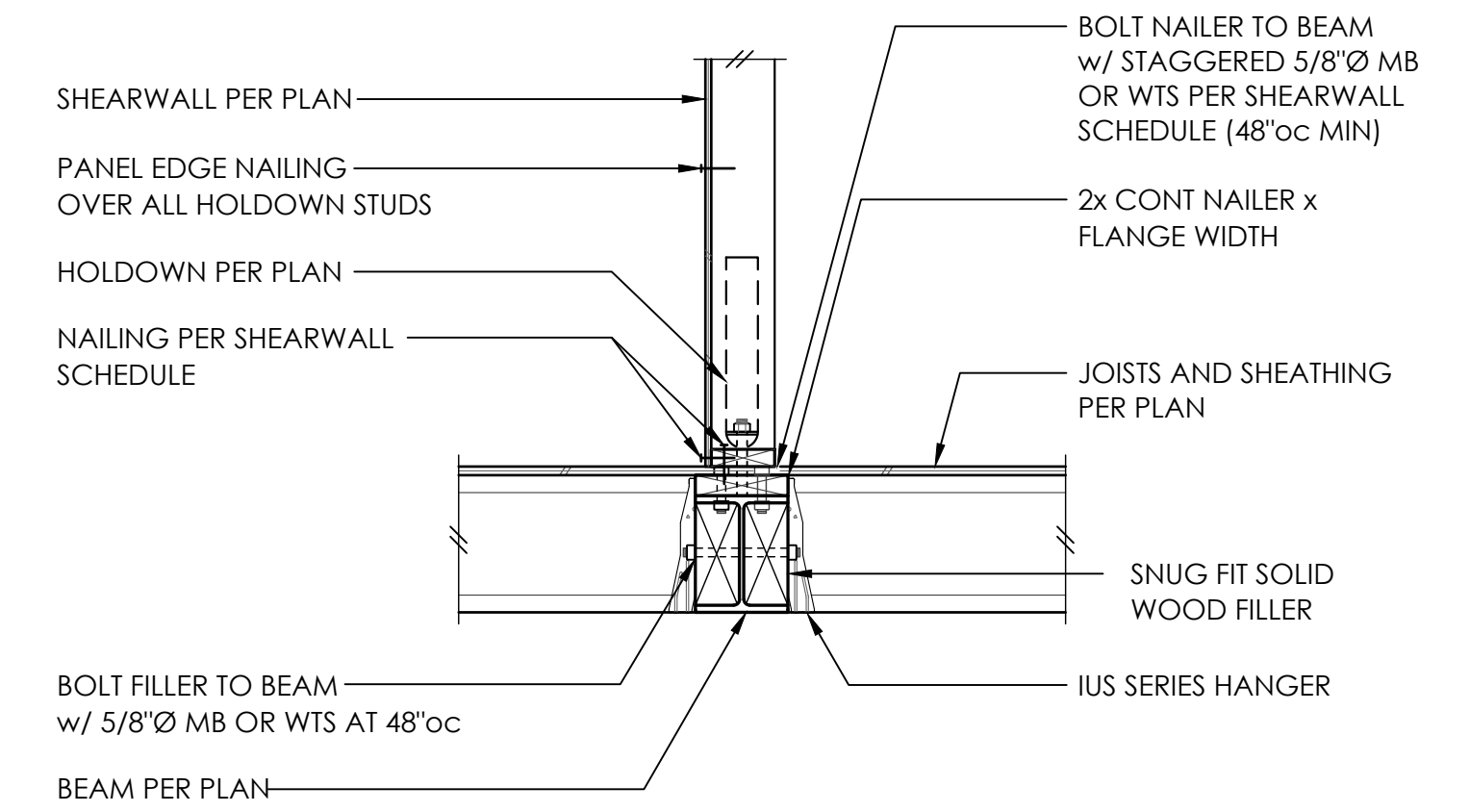

4

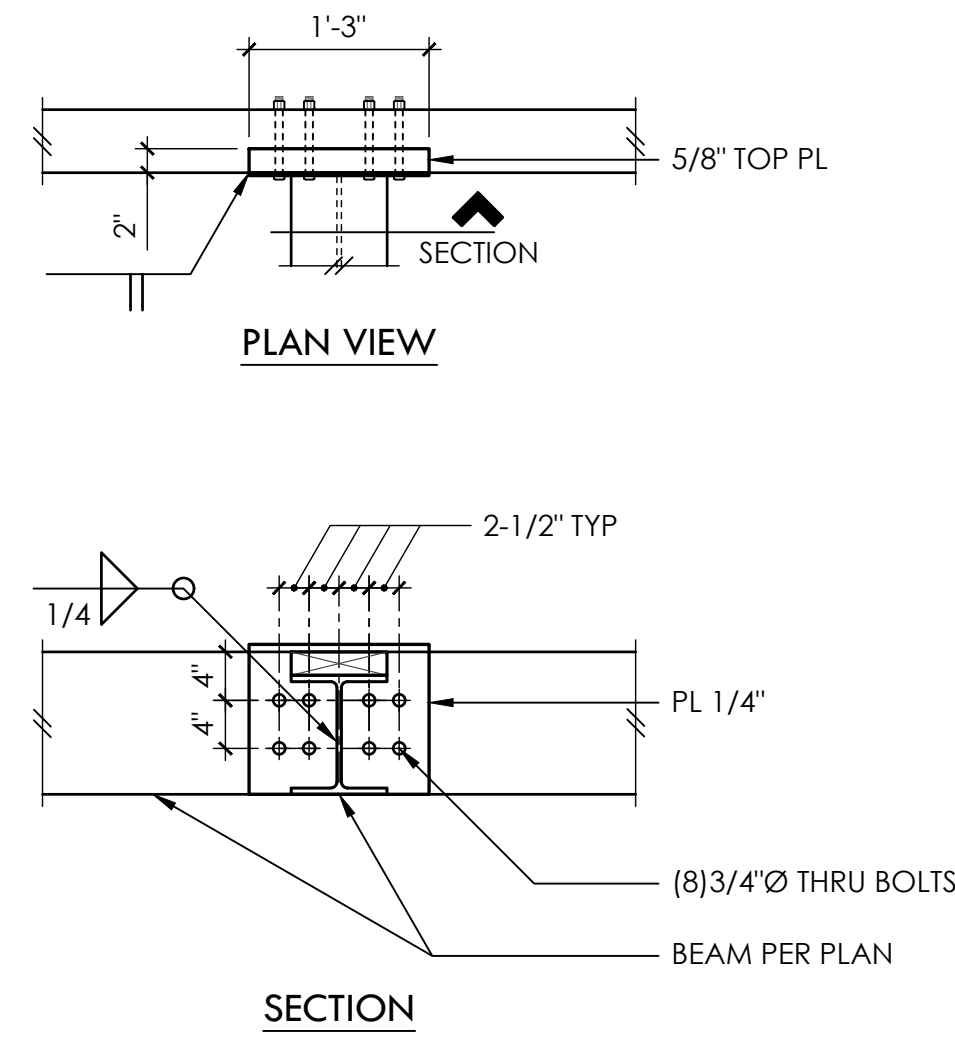

5

TYPICAL STEEL TO WOOD BEAM CONNECTION

6

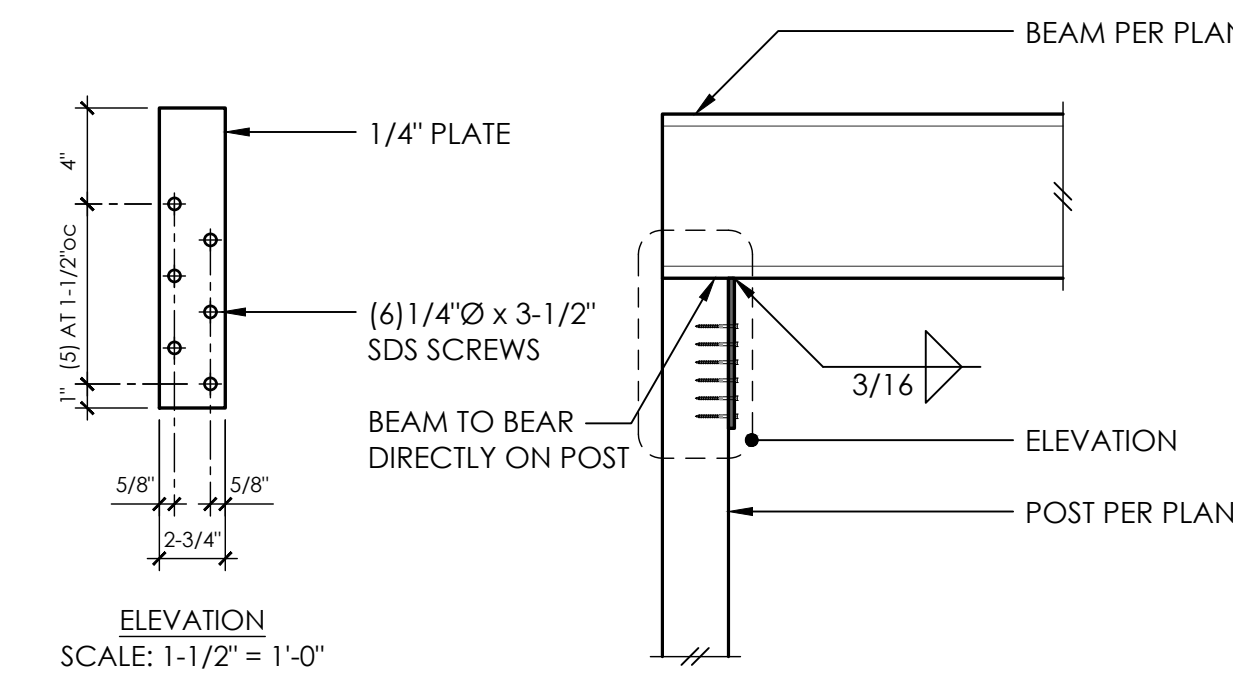

7

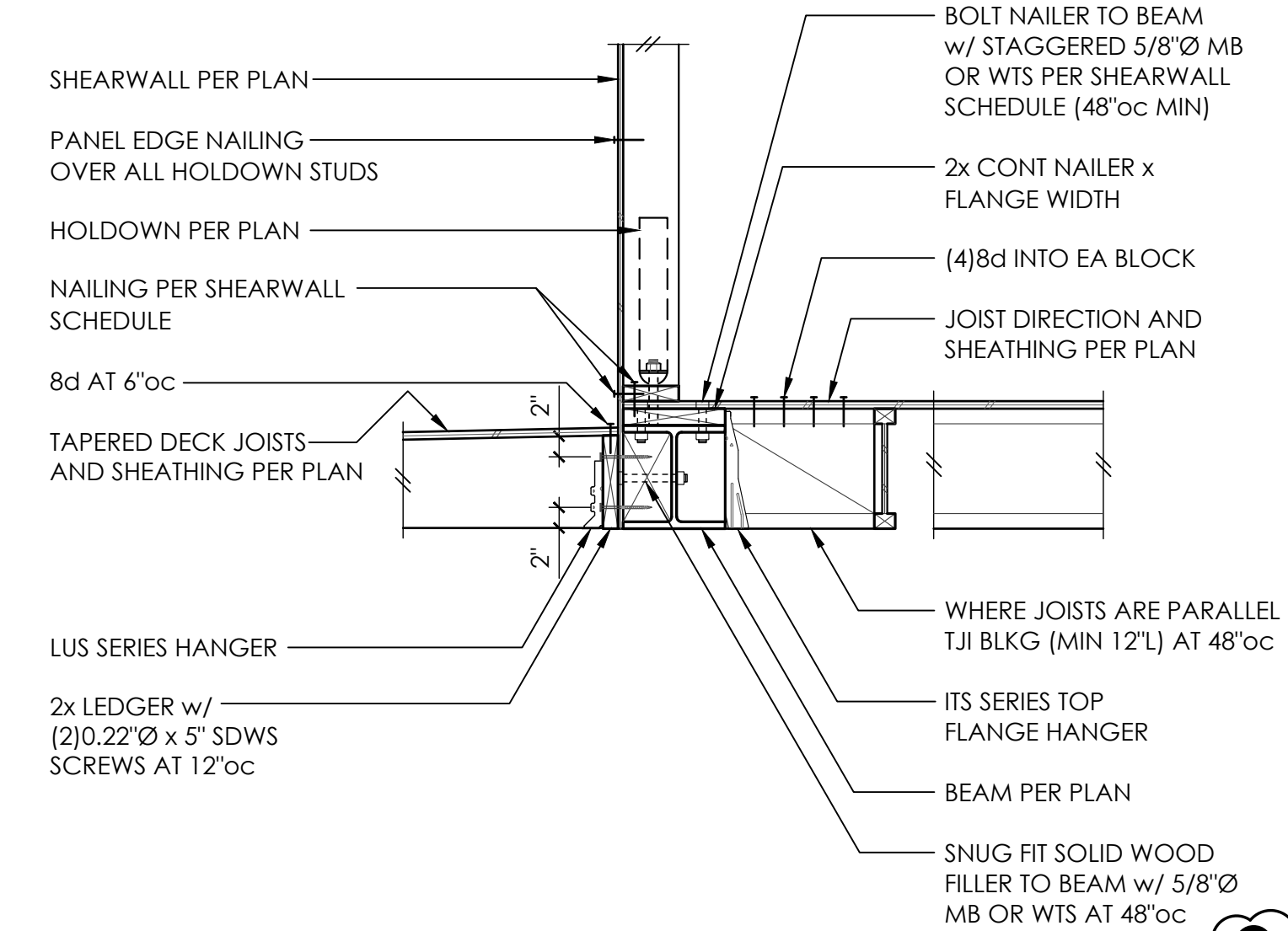

8

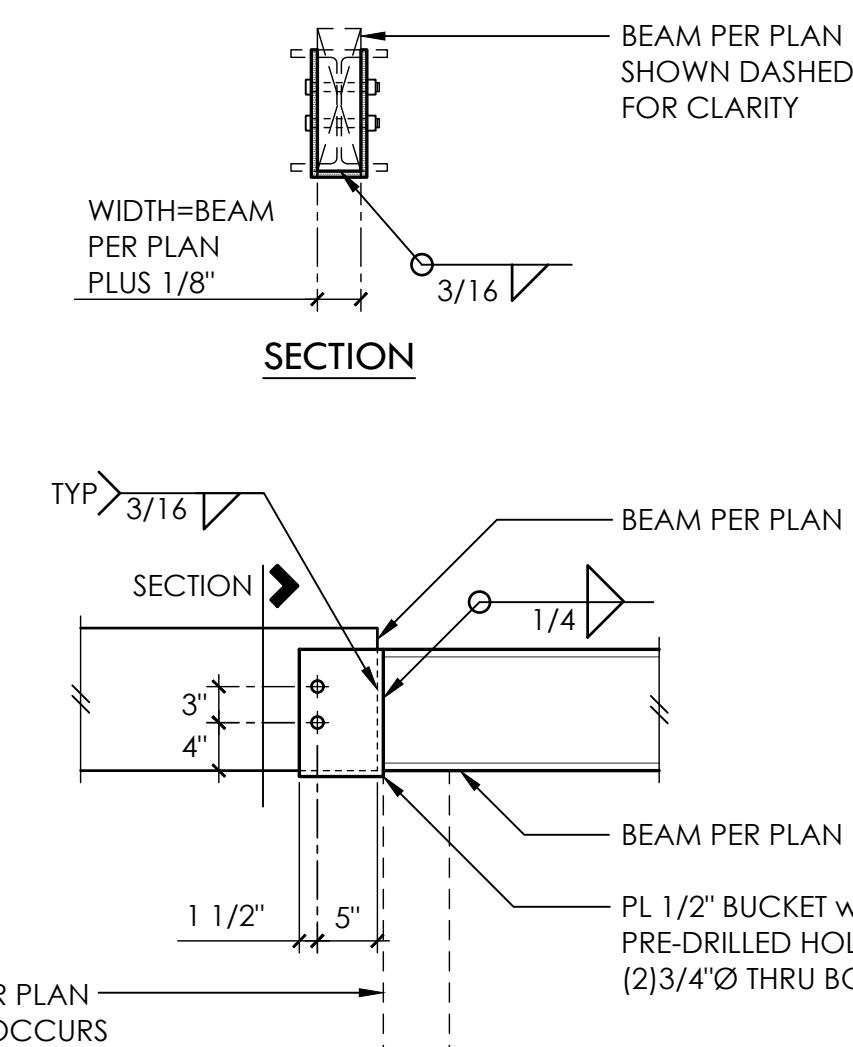

9

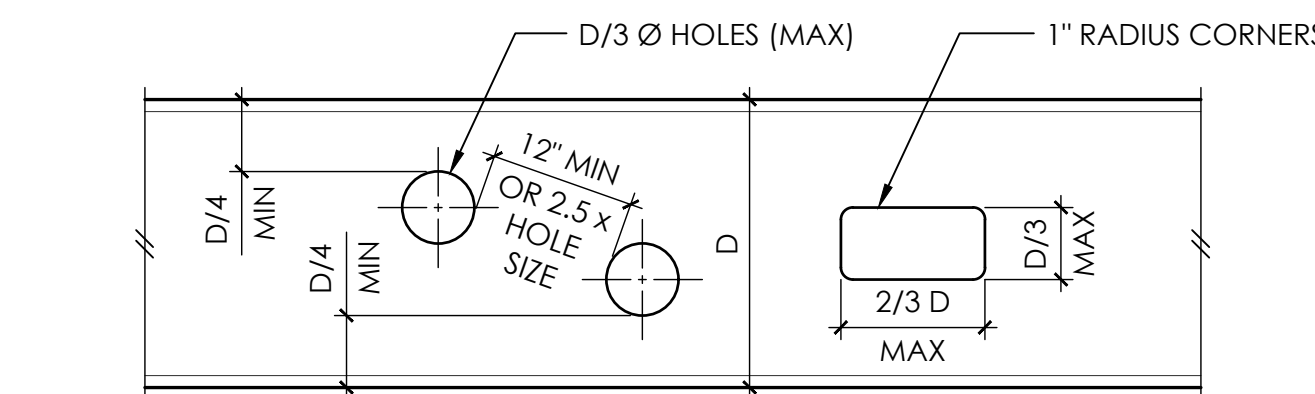

10

1. CONTRACTOR SHALL COORDINATE SIZES AND LOCATIONS OF ALL BEAM PENETRATIONS w/ MECHANICAL DRAWINGS. ALL PENETRATIONS LARGER THAN 2"Ø SHALL BE SHOWN ON SHOP DRAWINGS OR SKETCHES AND SHALL BE SUBMITTED TO THE ENGINEER FOR APPROVAL. FIELD CUTTING NOT PERMITTED WITHOUT APPROVAL.
2. OPENINGS MAY OCCUR IN MIDDLE HALF OF BEAM LENGTH ONLY.
3. NO CUTTING MAY OCCUR IN TOP OR BOTTOM QUARTER OF BEAM DEPTH.
4. ADJACENT OPENINGS MUST BE SPACED AT THE GREATER OF, 12" OR 2.5 x LARGER OPENING SIZE, EDGE TO EDGE.
5. MAXIMUM SIZES OF OPENINGS SHALL BE D/3 Ø OR D/3 x 2D/3 AS SHOWN.
6. NO OPENINGS SHALL OCCUR WITHIN 12" OF AN ADJACENT BEAM CONNECTION.
7. REQUIRED OPENINGS NOT MEETING ABOVE CRITERIA SHALL BE SUBMITTED TO ENGINEER FOR REINFORCING DESIGN.

TYPICAL STEEL BEAM PENETRATIONS

11

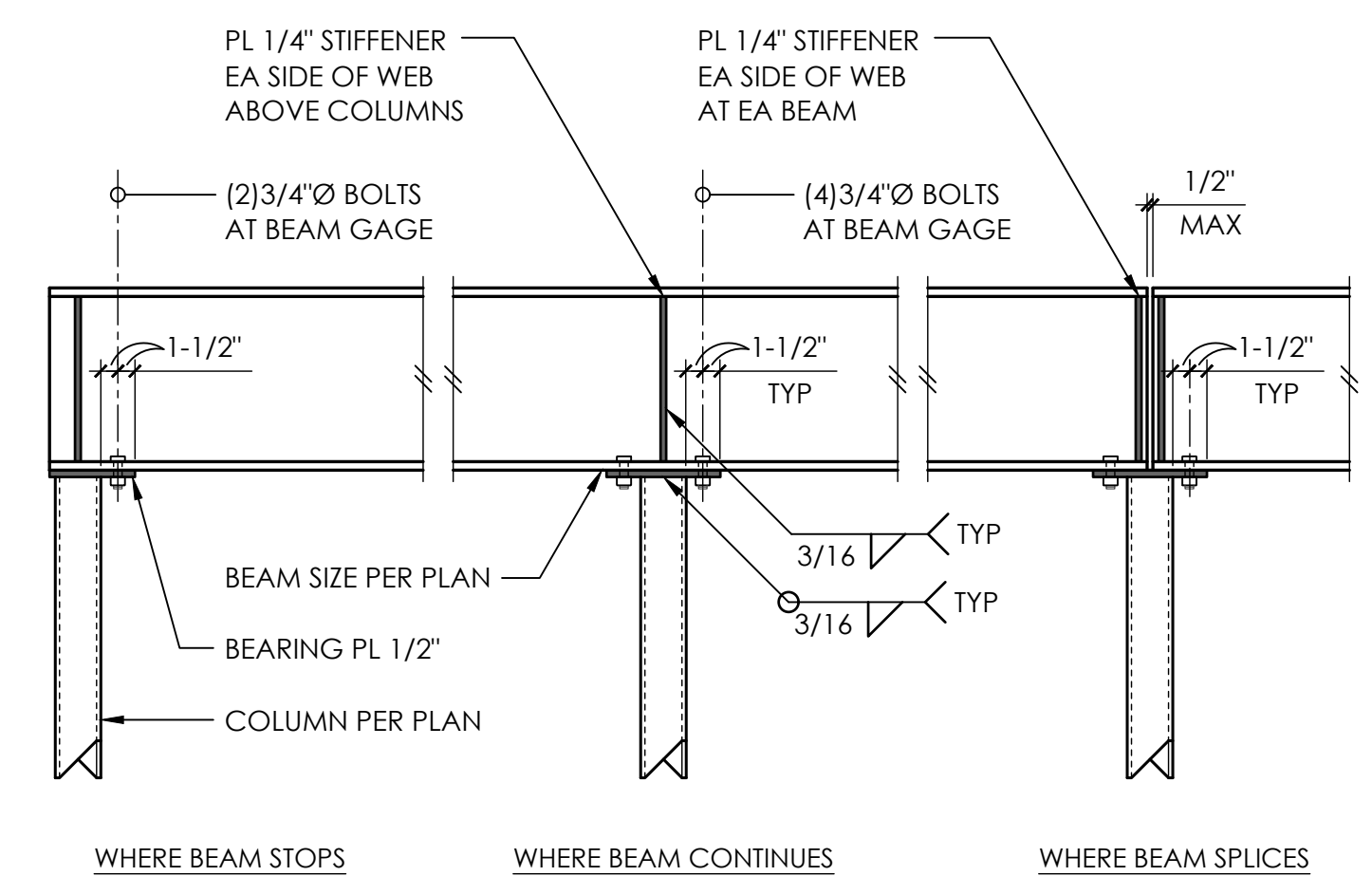

**NOTE**  
BEARING PLATE THICKNESS SHALL BE 3/4" WHERE DEPTH OF SUPPORTED MEMBER EXCEEDS 24"

12