



3009 112th Ave NE, Suite 100  
 Bellevue, WA 98004  
 T (425) 429-6645  
 F (888) 224-0299  
 mncustom.com  
 copyright © 2022

# MN472

## 7119 80TH AVE SE MERCER ISLAND, WA 98040

NFPA 13D SPRINKLER SYSTEM REQUIRED



CONSULTANT

STAMP

MN NO.

**MN472**

**7119 80TH AVE SE  
 MERCER ISLAND, WA 98040**

**COVER SHEET**

REVISION HISTORY

#	DATE	SUBMISSION
Δ		

DATE: 04-12-2024

SCALE: AS NOTED

SET TYPE: PERMIT

SHEET NUMBER

**A0.0**

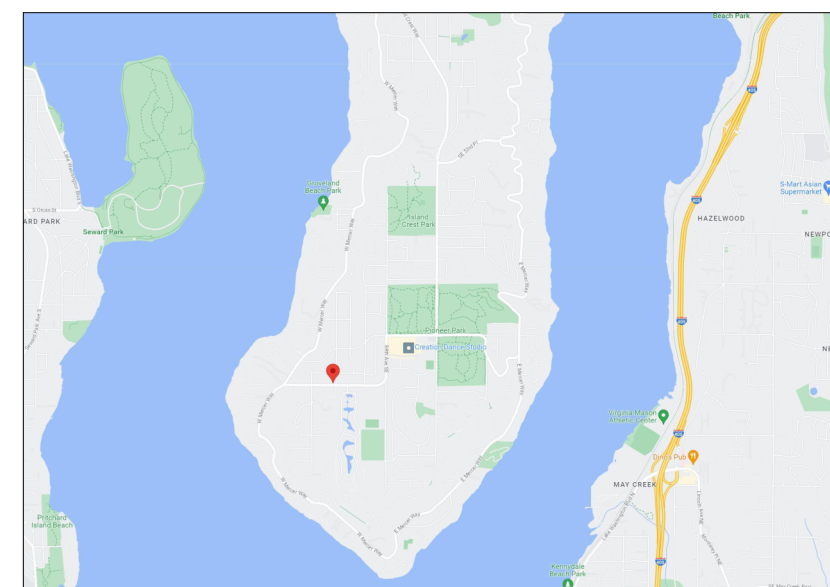

VICINITY MAP: 7119 80TH AVE SE

**PROJECT INFORMATION**

**OWNER**  
 HOME PROJECT 472, LLC  
 3009 112TH AVE NE, SUITE 100, BELLEVUE, WA 98004  
 ERIC SADLER  
 425.429.6645  
 PERMITS@MNCUSTOM.COM

**OWNER CONTACT**  
 ERIC SADLER  
 425.429.6645  
 ESADLER@MNCUSTOM.COM

**SITE ADDRESS** 7119 80TH AVE SE  
 MERCER ISLAND, WA 98040  
 915970-0050

**PARCEL** R-9B  
**JURISDICTION** MERCER ISLAND  
**PRESENT USE** SINGLE FAMILY RESIDENTIAL  
**PROPOSED USE** SINGLE FAMILY RESIDENTIAL  
**LOT AREA** 14,753 SF (.34 ACRES)

**LEGAL DESCRIPTION** LOT 6, BLOCK 2, WAMBA'S FIRST ADDITION TO MERCER ISLAND ACCORDING TO THE PLAT THEREOF RECORDED IN VOLUME 55 OF PLATS, PAGE 54, RECORDS OF KING COUNTY, WASHINGTON SITUATED IN THE COUNTY OF KING, STATE OF WASHINGTON.

**DEVELOPMENT INFORMATION**  
 REFER TO SITE PLAN FOR DOCUMENTATION RELATING TO LOT COVERAGE, FAR, GREENSPACE, IMPERVIOUS AREA, AVERAGE GRADE CALCULATION, DRIVEWAY

**NOTE:** A NFPA 13D FIRE SPRINKLER SYSTEM IN COMPLIANCE WITH NFPA 13D AND COMI STANDARDS SHALL BE INSTALLED THROUGHOUT THE RESIDENCE. A SEPARATE FIRE PERMIT IS REQUIRED.

**PROJECT TEAM**

**OWNER**  
 HOME PROJECT 472, LLC  
 3009 112TH AVE NE, SUITE 100, BELLEVUE, WA 98004  
 ERIC SADLER  
 425.429.6645  
 PERMITS@MNCUSTOM.COM

**GENERAL CONTRACTOR**  
 MN CUSTOM HOMES  
 3009 112TH AVE NE, SUITE 100, BELLEVUE, WA 98004  
 KARL LEWIS  
 425.429.6645  
 KARL@MNCUSTOM.COM

**SURVEYOR**  
 TERRANE  
 10801 MAIN STREET, SUITE 102, BELLEVUE, WA 98004  
 DANNY SLAGER  
 425.233.6088  
 DANNYS@TERRANE.NET

**CIVIL ENGINEER**  
 CE SOLUTIONS  
 102 NW CANAL ST, SEATTLE, WA 98107  
 DUFFY ELLIS  
 206.930.0342  
 DUFFY@CESOLUTIONS.US

**STRUCTURAL ENGINEER**  
 MALSAM TSANG ENGINEERING  
 122 S JACKSON ST, SUITE 210, SEATTLE, WA 98104  
 WARREN CENT  
 206.789.6038  
 WARRENC@MALSAM-TSANG.COM

**GEOTECHNICAL ENGINEER**  
 SOUTH FORK GEOSCIENCES  
 P.O. BOX 1275, NORTH BEND, WA 98045  
 ANDREW GLANDON  
 425-890-4858  
 ANDREW@SFGEO.COM

**SHEET INDEX**

#	SHEET NAME
A0.0	COVER SHEET
A0.1	PROJECT GENERAL INFORMATION
A0.2	ENERGY CODE COMPLIANCE
A0.3	ZONING ANALYSIS AND DIAGRAMS
A0.5	DOOR SCHEDULE AND ELEVATIONS
A0.6	WINDOW SCHEDULE AND ELEVATIONS
A1.1	SITE PLAN
A1.2	SITE DEMO PLAN
A2.1	CRAWLSPACE PLAN
A2.2	MAIN LEVEL FLOOR PLAN
A2.3	MAIN LEVEL RCP
A2.4	UPPER LEVEL FLOOR PLAN
A2.5	UPPER LEVEL RCP
A2.6	ROOF PLAN
A3.1	ELEVATIONS
A3.2	ELEVATIONS
A4.1	BUILDING SECTIONS
A4.2	BUILDING SECTIONS
A4.3	BUILDING SECTIONS
A9.1	PERMIT DETAILS
A9.2	PERMIT SOLAR DETAILS
A9.3	PERMIT SPRAY FOAM DETAILS







**GENERAL NOTES**

**GENERAL REQUIREMENTS**

- BUILDING CODE 2018 INTERNATIONAL RESIDENTIAL CODE (IRC) WITH WA STATE AMENDMENTS (WAC 51-51)
- ELECTRICAL CODE 2020 NATIONAL ELECTRICAL CODE (NEC) WITH WA STATE AMENDMENTS (WAC 296-46B) AND/ RCW 19.28)
- ENERGY CODE 2018 WASHINGTON STATE ENERGY CODE (WSEC) RESIDENTIAL PROVISIONS (WAC 51-11R)
- FIRE CODE 2018 INTERNATIONAL FIRE CODE (IFC) WITH WA STATE AMENDMENTS (WAC 51-54A)
- MECHANICAL CODE 2018 INTERNATIONAL MECHANICAL CODE (IMC) WITH WA STATE AMENDMENTS (WAC 51-52)
- NATIONAL FUEL GAS CODE 2018 NFPA 54, NATIONAL FUEL GAS CODE (NFGC) (WAC 51-52)
- PLUMBING CODE 2018 UNIFORM PLUMBING CODE (UPC) WITH WA STATE AMENDMENTS (WAC 51-56)

**CONTRACTOR RESPONSIBILITIES**

IT IS THE RESPONSIBILITY OF THE GENERAL CONTRACTOR (GC) TO ENSURE COMPLIANCE AND CONFORMANCE WITH THE VARIOUS PROVISIONS OF THE APPLICABLE ORDINANCES AND CODES IN ALL THE WORK. THE GC IS RESPONSIBLE FOR COORDINATING ALL WORK INCLUDING ADDITIONAL PERMITS AND SUBCONTRACTOR WORK.

**DIMENSIONS**

DIMENSIONS THAT ARE NOT STATED AS "MAXIMUM" OR "MINIMUM" ARE ABSOLUTE. ALL DIMENSIONS ARE SUBJECT TO CONVENTIONAL INDUSTRY TOLERANCES. VERIFY AND COORDINATE DIMENSIONS AMONG ALL DRAWINGS PRIOR TO CONSTRUCTION. WRITTEN DIMENSIONS TAKE PRECEDENCE OVER SCALED LENGTHS AND HEIGHTS IN ALL CASES. DO NOT SCALE DRAWINGS. DIMENSIONS ARE SHOWN AT FACE OF CONCRETE, CENTERLINE OF ROUGH OPENINGS, FACE OF FRAMING

**DISCREPANCIES**

IN THE EVENT OF DISCREPANCIES OR CONTRADICTORY INFORMATION IN THE DRAWINGS, NOTES, OR SPECIFICATIONS, IT IS THE OBLIGATION OF THE GC TO NOTIFY DESIGN TEAM OF THE SAME AND TO OBTAIN CLARIFICATION FROM DESIGN TEAM BEFORE PROCEEDING WITH THE WORK.

**INSPECTIONS**

- CONTRACTOR SHALL BE RESPONSIBLE FOR COORDINATING ALL BUILDING INSPECTIONS. REQUIRED BUILDING INSPECTIONS PER IRC SECTION R109 AND WSEC 105.
- FOUNDATION INSPECTION - AFTER FORMS ARE ERECTED AND REINFORCING STEEL IS PLACED
- PLUMBING, MECHANICAL, GAS, AND ELECTRICAL SYSTEMS INSPECTION - PRIOR TO COVERING/CONCEALMENT
- FRAME AND MASONRY INSPECTION - AFTER THE ROOF, MASONRY, FIRESTOPPING, DRAFTSTOPPING, AND BRACING ARE IN PLACE AND AFTER PLUMBING, MECHANICAL, AND ELECTRICAL ROUGH INSPECTIONS ARE APPROVED
- SPECIAL INSPECTIONS AS REQUIRED BY ENGINEER OF RECORD OR JURISDICTION OTHER INSPECTIONS REQUIRED BY THE BUILDING OFFICIAL
- FINAL INSPECTION - AFTER THE PERMITTED WORK IS COMPLETE AND PRIOR TO OCCUPANCY.

**CONTRACT DOCUMENTS**

MN CUSTOM HOMES SHALL HAVE FINAL AUTHORITY REGARDING INTERPRETATION OF THE INTENT AND SPIRIT OF THE CONTRACT DOCUMENTS. REFER TO PROJECT SPECIFICATIONS. ALL CONTRACT DOCUMENTS PERTAINING TO THIS PROJECT ARE TO BE CONSIDERED AND INTERPRETED FOR BIDDING AND CONSTRUCTION PURPOSES AS A COMPLETE WHOLE. NO PART OF THE DRAWINGS SHALL BE DISTRIBUTED, CONSIDERED, OR USED IN ANY WAY INDEPENDENT OF THE COMPLETE SET OF DOCUMENTS

**TYPICAL DETAILS**

PROJECT DRAWINGS INDICATE GENERAL AND TYPICAL DETAILS OF CONSTRUCTION WHERE CONDITIONS ARE NOT SPECIFICALLY INDICATED BUT ARE OF SIMILAR CHARACTER TO DETAILS SHOWN. SIMILAR DETAILS OF CONSTRUCTION TO THOSE PROVIDED SHALL BE USED - SUBJECT TO REVIEW AND APPROVAL BY DESIGN TEAM AND THE STRUCTURAL ENGINEER.

**SUBMITTALS**

SHOP DRAWINGS ARE REQUIRED FOR THE FOLLOWING COMPONENTS: ITEMS REQUIRED BY CONSULTANTS - SEE INDIVIDUAL CONSULTANT DOCUMENTATION FOR ANY SHOP DRAWINGS REQUIRED BY THEIR RESPECTIVE DISCIPLINES, WINDOWS AND DOORS, CANOPIES, GATES, AND SPECIALTY DOORS RAILING SYSTEMS, CASEWORK, AND BUILT-INS

**CHANGES**

CONTRACTOR INITIATED CHANGES SHALL BE SUBMITTED IN WRITING TO DESIGN TEAM AND/OR STRUCTURAL ENGINEER FOR APPROVAL PRIOR TO FABRICATION OR CONSTRUCTION. CHANGES SHOWN ON SHOP DRAWINGS ONLY DO NOT SATISFY THIS REQUIREMENT UNLESS PREVIOUSLY APPROVED. WHERE CHANGES - WHETHER DRAWING OR FIELD REQUIRED - IMPACT AN APPROVED PERMIT SHALL HAVE REVISIONS APPROVE & FILED FOR RECORD W/ THE CITY ONCE THE ORIGINAL SUBMISSION HAS BEEN APPROVED AND THE PERMIT ISSUED. CHANGE WILL BE MADE BY CITY FOR ALL REVISION REVIEW AND APPROVALS INCLUDING FIELD INSPECTIONS BEYOND THAT REQUIRED UNDER PERMIT FEES AND PAID FOR UNDER ESTIMATED INSPECTION FEE.

**AS-BUILT DRAWINGS**

CONTRACTOR AND SUBCONTRACTORS SHALL MARK DRAWINGS FOR AS-BUILT CONDITION. MECHANICAL, ELECTRICAL, PLUMBING, AND FIRE PROTECTION DRAWINGS SHALL BE REVISED FOR AS-BUILT CONDITIONS BY THEIR RESPECTIVE AUTHORS. FINAL AS-BUILT REPRODUCIBLE DRAWINGS SHALL BE SUBMITTED TO THE OWNER OR OWNER'S REPRESENTATIVE.

**SAFETY**

CONTRACTOR SHALL BE RESPONSIBLE FOR ALL REQUIRED SAFETY PRECAUTIONS AND THE METHODS, TECHNIQUES, SEQUENCES, OR PROCEDURES REQUIRED TO PERFORM THE WORK. USE OF TEMPORARY AND PERMANENT ROOF ANCHORS FOR ABOVE GROUND WORK ARE REQUIRED. SEE ROOF ACCESS AND FALL PROTECTION NOTES

**SITE MAINTENANCE**

CONTRACTOR SHALL MAINTAIN A TRASH BIN IN AN AREA DESIGNATED BY THE OWNER'S REPRESENTATIVE FOR THE COLLECTION OF ALL CONSTRUCTION DEBRIS. CONTRACTOR SHALL DISPOSE OF ALL DEBRIS AND REMOVE TRASH PRIOR TO OCCUPANCY ALL SURFACES SHALL BE CLEANED PRIOR TO OCCUPANCY.

**DEMOLITION PERMIT**

VERIFY PER JURISDICTION: A SEPARATE DEMOLITION PERMIT IS REQUIRED FOR THE REMOVAL OF ANY EXISTING STRUCTURE.

**DESIGN CRITERIA**

CONSTRUCTION TYPE BUILDINGS SHALL BE CONSTRUCTED OF TYPE-V WOOD LIGHT-FRAME SYSTEMS ENGINEERED DESIGNS SHALL COMPLY WITH THE INTERNATIONAL BUILDING CODE. SEISMIC DESIGN CATEGORY **d** (SEE GEOTECHNICAL REPORT AND STRUCTURAL DRAWINGS)

**EGRESS AND STAIRS**

**STAIRS**

- PROVIDE 1/2 INCH GYP AT ENCLOSED AND ACCESSIBLE UNDERSTAIR SPACES - ALL SIDES. ALL STAIRS, HANDRAILS, AND GUARDRAILS SHALL CONFORM TO IRC SECTION 311 AND 312
- STAIRWAYS SHALL HAVE A CLEAR HEIGHT OF 80" ABOVE NOSING
- STAIRS SHALL COMPLY WITH R311.7, NOT LESS THAN 36" IN WIDTH.
- STAIRS SHALL HAVE A MINIMUM TREAD DEPTH OF 10" AND A MAXIMUM RISER HEIGHT OF 7 3/4"

**EGRESS OPENINGS**

EMERGENCY ESCAPE AND RESCUE OPENINGS SHALL HAVE A MINIM NET CLEAR OPENING OF 5.7 SQ. FT. EXCEPT GRADE FLOOR OPENINGS SHALL BE 5 SQ. FT. MINIMUM. THE MINIMUM NET CLEAR OPENING HEIGHT DIMENSION SHALL BE 24" AND THE MINIMUM NET CLEAR OPENING WIDTH DIMENSION SHALL BE 20" PER IRC SECTION R310. T-SILL OF THE OPENING SHALL BE NOT MORE THAN 44 INCHES ABOVE THE FLOOR. PROVIDE ONE EGRESS WINDOW PER BEDROOM

**HANDRAILS**

PROVIDE AT LEAST ONE HANDRAIL AT EVERY STAIRWAY HAVING FOUR OR MORE RISERS. PROVIDE 2 HANDRAILS WHERE SHOWN ON PLANS. HANDRAILS SHALL BE CONTINUOUS THE FULL LENGTH OF THE FLIGHT FROM A POINT DIRECTLY ABOVE THE TOP RISER OF A FLIGHT A POINT DIRECTLY ABOVE THE LOWEST RISER OF THE FLIGHT AND SHALL BE RETURNED OR TERMINATE IN NEWEL POSTS. HANDRAILS ARE PERMITTED TO BE INTERRUPTED BY NEWEL POSTS AT THE TURN, AND MAY START OVER THE LOWEST TREAD.

HANDRAIL HEIGHT, MEASURED ABOVE STAIR TREAD NOSINGS, OR FINISH SURFACE OF RAM SLOPE, SHALL BE UNIFORM, NOT LESS THAN 34" AND NOT MORE THAN 38". HANDRAILS WITH CIRCULAR CROSS SECTION SHALL HAVE AN OUTSIDE DIAMETER OF AT LEAST 1.25" AND NOT GREATER THAN 2" OR SHALL PROVIDE EQUIVALENT GRASPABILITY. IF THE HANDRAIL IS NOT CIRCULAR, IT SHALL HAVE A PERIMETER DIMENSION OF AT LEAST 4" AND NOT GREATER THAN 6.25" WITH A MAXIMUM CROSS-SECTION DIMENSION OF 2.25".

**GUARDS**

GUARDS SHALL BE LOCATED ALONG OPEN-SIDED WALKING SURFACES, MEZZANINES, INDUSTRIAL EQUIPMENT PLATFORMS, STAIRWAYS, RAMPS AND LANDINGS WHICH ARE LOCATED MORE THAN 30" ABOVE THE FLOOR OR GRADE BELOW. GUARDS SHALL BE ADEQUATE IN STRENGTH AND ATTACHMENT IN ACCORDANCE WITH SECTION 1607.7, (IBC SEC. 1012.1) GUARDS WHOSE TOP RAIL IS ALSO SERVED AS A HANDRAIL SHALL HAVE A HEIGHT NOT LESS THAN 34" AND NOT MORE THAN 38" MEASURED VERTICALLY FROM THE LEADING EDGE OF THE STAIR TREAD NOSING. (IBC SEC. 1012.2)

OPEN GUARDS SHALL HAVE BALUSTERS OR ORNAMENTAL PATTERNS SUCH THAT A 4"-DIAMETER SPHERE CANNOT PASS THROUGH ANY OPENING UP TO A HEIGHT OF 34". FROM HEIGHT OF 34" TO 42" ABOVE THE ADJACENT WALKING SURFACES, A SPHERE 8" IN DIAMETER SHALL NOT PASS. EXCEPTIONS: THE TRIANGULAR OPENINGS FORMED BY THE RISER, TREAD AND BOTTOM RAIL AT THE OPEN SIDE OF A STAIRWAY SHALL BE OF A MAXIMUM SIZE SUCH THAT A SPHERE OF 6" IN DIAMETER CANNOT PASS THROUGH THE OPENING PER IRC SECTION R312

**FIRE PROTECTION SYSTEMS**

BIDDER DESIGNED. FIRE PROTECTION SYSTEMS SHALL BE BIDDER DESIGNED. DESIGNATED SUBCONTRACTORS ARE RESPONSIBLE FOR THE PREPARATION OF DRAWINGS AND APPLICATIONS FOR APPROPRIATE REQUIRED PERMITS.

**SPRINKLER SYSTEM**

A SPRINKLER SYSTEM IS REQUIRED FOR THE HOUSE. FIRE SPRINKLERS ARE REQUIRED: (IFC 903 & 907). AUTOMATIC SPRINKLERS MUST BE INSTALLED THROUGHOUT THE DWELLING IN ACCORDANCE WITH IFC 903 AND NFPA 13D

**SMOKE ALARM SYSTEM**

AN APPROVED SMOKE ALARM SYSTEM WITH AUTOMATIC SMOKE DETECTORS SHALL BE PROVIDED AND INSTALLED IN ACCORDANCE WITH NFPA 72 AND IRC SECTION R314. PROVIDED ALARMS INSIDE OF EACH BEDROOM, OUTSIDE OF EACH SLEEPING AREA, AND ON EACH STORY OF THE DWELLING NOT LESS THAN 3 FEET FROM THE DOOR OF A BATHROOM CONTAINING A TUB OR SHOWER. REQUIRED SMOKE ALARMS SHALL BE HARDWIRED TO BUILDING POWER, INTERCONNECTED, AND HAVE A BATTERY BACKUP.

**CARBON MONOXIDE ALARMS**

PROVIDE CO ALARMS OUTSIDE OF EACH SEPARATE DWELLING AREA IN THE IMMEDIATE VICINITY OF THE BEDROOMS. CO ALARMS MAY BE PART OF A COMBINATION CARBON MONOXIDE/SMOKE ALARM. REQUIRED ALARMS SHALL BE HARDWIRED TO BUILDING POWER AND HAVE BATTERY BACKUP.

**HEAT ALARMS**

PROVIDE HEAT ALARM IN EACH ATTACHED GARAGE PER R314.2.3 AND R314 HEAT ALARMS SHALL BE CONNECTED TO A HEAT ALARM OR SMOKE ALARM THAT IS INSTALLED IN THE DWELLING UNIT.

**SOILS AND FOUNDATIONS**

**SOILS**

EXCAVATIONS SHALL BE INSPECTED BY THE GEOTECHNICAL ENGINEER PRIOR TO POURING CONCRETE IF REQUIRED.

**PERIMETER DRAINS**

PROVIDE CONTINUOUS 4" ROUND PERFORATED DRAIN IN GRAVEL FILL WITH FILTER FABRIC WRAP AT ALL FOUNDATION WALLS. PROVIDE CLEAN-OUTS SUCH THAT ALL PORTIONS OF DRAINAGE SYSTEM CAN BE ADEQUATELY CLEANED. LOCATE BOTTOMS OF DRAIN PIPES AT THE LOWEST POINT OF WALL FOOTINGS AND TIGHT-LINE PERIMETER DRAINS STORM SEWER OR OTHER APPROVED DISCHARGE. DO NOT CONNECT THE PERIMETER / FOUNDATION DRAIN TO ANY OTHER TIGHT-LINES OR SITE DRAINAGE SYSTEMS.

PROVIDE A MINIMUM 12" THICK LAYER OF CONTINUOUS GRAVEL FILL FROM BOTTOM OF FOOTING TO WITHIN 12" OF FINISH GRADE - TYPICAL AT ALL WALLS. APPROVED GRAVEL FILL CONSISTS OF WASHED, CLEAN, FREE DRAINAGE GRAVEL RANGING FROM 1/4" TO 3/4" IN SIZE.

**DAMP-PROOFING**

PROVIDE DAMP-PROOFING ON THE EXTERIOR SURFACE OF NEW FOUNDATION WALLS FROM THE TOP OF THE FOOTING TO FINISHED GRADE. DAMP-PROOFING SHALL CONSIST OF A BITUMINOUS MATERIAL, 3 LBS PER SQ. YD. OF A MODIFIED CEMENT, 1/8" COAT OF SURFACE-BONDING MORTAR COMPLYING WITH ASTM C 887, ANY O THE MATERIALS PERMITTED FOR WATERPROOFING BY SECTION R406.2 OR OTHER APPROVE METHODS OR MATERIALS.

**SITE DRAINAGE**

CONFORM TO ALL LOCAL REGULATIONS AND ORDINANCES. TIGHTLINE ALL ROOF DRAINS TO STORM SEWER SYSTEM OR APPROVED DISCHARGE WHEN STORM SEWERS ARE NOT AVAILABLE. DO NOT CONNECT FOUNDATION AND RETAINING WALL PERIMETER FOOTING DRAINS TIGHT-LINE TO ROOF DRAIN TIGHT-LINES OR OTHER SITE DRAINAGE.

**FINISH GRADE**

PROVIDE A POSITIVE SLOPE AWAY FROM THE BUILDING AT THE BUILDING FACE AT ALL SIDES FOR A MINIMUM OF 4 FEET WITH A DROP OF 3". ALL SITE HARD SURFACES TO HAVE A MINIMUM SLOPE OF 1/8" IN 12" TO DRAINS UNLESS NOTED OTHERWISE.

**DEBRIS**

REMOVE ALL VEGETATION AND ORGANIC MATERIAL INCLUDING WOOD FORMWORK AND CONSTRUCTION DEBRIS FROM THE UNDER-FLOOR AREA BEFORE THE BUILDING IS OCCUPIED.

**UNDER-FLOOR VENTILATION**

VENTED CRAWL SPACE SHALL BE UTILIZED PER IRC 408. REFER TO ASSEMBLIES, CRAWL SPACE PLAN FOR CALCULATIONS AND QUANTITIES, ELEVATIONS, AND PERMIT DETAILS. AT VENTS LOCATED BELOW THE PLANE OF EARTH, PROVIDE VENT WELL. PROVIDE CONTINUOUS ROCK FILL TO THE PERIMETER FOUNDATION DRAIN AND INCLUDE FILTER FABRIC.

**CRAWLSPACE ACCESS**

CRAWL SPACES SHALL BE PROVIDED WITH A MINIMUM OF ONE FLOOR ACCESS OPENING NOT LESS THAN 18 INCHES BY 24 INCHES, OR ONE WALL ACCESS NOT LESS THAN 16 INCHES BY 24 INCHES.

**STRUCTURAL SYSTEMS**

**STRUCTURAL SYSTEMS**

ALL STRUCTURAL SYSTEMS (SUCH AS TRUSSES) WHICH ARE TO BE COMPOSED OF COMPONENTS TO BE FIELD ERECTED SHALL BE SUPERVISED BY THE SUPPLIER DURING MANUFACTURING, DELIVERY, HANDLING, STORAGE, AND ERECTION IN ACCORDANCE WITH INSTRUCTIONS PREPARED BY THE SUPPLIER

**EXTERIOR STRUCTURES**

EXTERIOR WOOD FRAMED DECKS AND OTHER WOOD FRAMED STRUCTURES EXPOSED TO WEATHER: ALL WOOD SHALL BE PRESSURE TREATED TO CURRENT AMERICAN WOOD PRESERVERS INSTITUTE STANDARDS. THIS INCLUDES ALL PLYWOOD, TRUSSES, SAWN MEMBERS, GLUE-LAMINATED MEMBERS, ETC., UNLESS NOTED OTHERWISE. ALL NAILS AND CONNECTORS SHALL BE HEAVY-COAT GALVANIZED. AT EXPOSED BEAMS USE KILN DRIED DOUG FIR #1.

**MECHANICAL SYSTEMS**

**BIDDER DESIGNED**

MECHANICAL SYSTEMS, ELECTRICAL SYSTEMS, AND PLUMBING SYSTEMS SHALL BE BIDDER DESIGNED. SUBCONTRACTORS DESIGNATED TO ACCOMPLISH THE ABOVE WILL BE RESPONSIBLE FOR THE PREPARATION OF DRAWINGS AND APPLICATIONS FOR APPROPRIATE REQUIRED PERMITS.

**MECHANICAL**

ALL PILOTS, BURNERS, AND SWITCHES TO BE MIN 18 INCHES ABOVE SLAB. DUCTS IN THE GARAGE AND DUCTS PENETRATING THE WALLS OR CEILINGS SHALL BE CONSTRUCTED OF 26 GAUGE SHEET STEEL AND SHALL HAVE NO OPENINGS INTO THE GARAGE. AIR EXHAUST OPENINGS SHALL TERMINATE NOT LESS THAN 3 FEET FROM PROPERTY LINES, 3 FEET FROM OPERABLE AND NON-OPERABLE OPENINGS INTO THE RESIDENCE AND 10 FEET FROM MECHANICAL AIR INTAKES. ALL BATHROOM FANS, KITCHEN HOOD, AND DRYER DUCTS SHALL BE EXHAUSTED THROUGH THE ATTIC TO THE ROOF OR THROUGH THE FLOOR SYSTEM TO AN OUTSIDE WALL. AT LEAST ONE THERMOSTAT SHALL BE PROVIDED FOR EACH SEPARATE HEATING AND COOLING SYSTEM PER R403.1. SEAL ALL DUCTS, AIR HANDLERS, AND FILTER BOXES PER R403.2. GARRING CAPABLE OF CARRYING FLUIDS OVER 150" AND BELOW 55" TO MIN R-6 PER R403.3. HEATING AND COOLING EQUIPMENT SHALL BE SIZED IN ACCORDANCE WITH ACCA MANUAL S BASED ON LOADS CALCULATED IN ACCA MANUAL J OR OTHER APPROVED HEATING AND CALC METHODOLOGIES PER R403.6

**VENTILATION**

PROVIDE SOURCE SPECIFIC AND WHOLE HOUSE VENTILATION. PROVIDE EXHAUST FANS VENTED TO THE EXTERIOR IN THE FOLLOWING LOCATIONS: BATHROOMS, POWDER ROOMS, LAUNDRY ROOMS, AND KITCHENS. EXHAUST FAN CFM CALLOUTS ARE MINIMUMS. SPECIFIED EQUIPMENT SHALL MEET OR EXCEED FLOW NOTED.

**WHOLE-HOUSE VENTILATION**

CONTINUOUS WHOLE-HOUSE VENTILATION SHALL BE INTEGRATED WITH THE FORCED-AIR HEATING SYSTEM. OUTDOOR AIR SHALL BE PROVIDED TO THE RETURN SIDE OF THE FORCED-AIR SYSTEM WITHIN 4 FEET UPSTREAM OF THE UNIT. AT A MINIMUM, FILTRATION SHALL BE PROVIDED AT THE FORCED-AIR UNIT WITH ADEQUATE ACCESS TO FILTERS FOR MAINTENANCE AND REPLACEMENT. SYSTEM(S) SHALL COMPLY WITH R403.5 AND SHALL HAVE AUTOMATIC OR GRAVITY DAMPERS THAT CLOSE WHEN SYSTEM IS NOT ACTIVE. PROVIDE MANUAL OVERRIDE FOR WHOLE HOUSE FANS USED IN TIMES OF BAD AIR QUALITY.

**EXHAUST FANS**

INTERMITTENT WHOLE-HOUSE FAN SHALL BE CAPABLE OF OPERATING AT LEAST 25% OF EACH 4-HOUR PERIOD.

TABLE M1597.3.3(1) RATE= 105 CFM  
VENTILATION RATE PROVIDED: 200  
CFM OPERATING TIME: 50 OF EACH 4-HOUR PERIOD (2 HOURS)

**TOILET, BATH, AND SHOWER SPACES**

SHOWER COMPARTMENTS AND WALLS ABOVE BATHTUBS WITH INSTALLED SHOWER HEADS SHALL BE FINISHED WITH A NON-ABSORBENT SURFACE TO A HEIGHT NOT LESS THAN 6 FEET ABOVE THE FLOOR. SHOWER FLOW LIMITED TO 2.5 GAL/MIN. TUB/SHOWER UNITS SHALL HAVE FIRE BLOCKING BETWEEN WALL STUDS AND WATERPROOF SURROUNDINGS TO -72" FROM DRAIN.

**PLUMBING SUPPLY**

INSULATE HOT WATER DISTRIBUTION TO MIN R-6 PER R403.3. ALL OPENINGS MADE IN WALLS, FLOORS, OR CEILINGS FOR THE PASSAGE OF PIPES, STRAINER PLATES ON DRAIN INLETS, TUB WASTE OPENINGS TO CRAWLSPACE, AND METER BOXES TO COMPLY WITH 2018 UPC

**WATER HEATERS**

PROVIDE SEISMIC ANCHOR STRAPS FOR ALL WATER TANKS. ALL HOT WATER TANKS SHALL BE EQUIPPED WITH:

- PRESSURE RELIEF VALVE DISCHARGING TO THE EXTERIOR OF THE BUILDING AND TERMINATING 6" TO 24" ABOVE GRADE
- THERMAL EXPANSION TANK IF THE WATER SYSTEM IS EQUIPPED WITH A PRESSURE REDUCING VALVE OR A CHECK VALVE.
- PROVIDE PAN UNDER HOW WATER TANK PER UPC 507.5
- PROVIDE MECHANICAL PLATFORM MIN 18" ABOVE SLAB. PROVIDE (2) LAYERS 3/4" PLYWOOD.

**FACTORY-BUILT FIREPLACES**

FACTORY-BUILT FIREPLACES SHALL BEAR UL 127 OR ICBO SEAL OF APPROVAL & BE INSTALLED PER MANUFACTURER RECOMMENDATIONS. FIREPLACES SHALL BE INSTALLED WITH TIGHT-FITTING GLASS DOORS & OUTSIDE SOURCE OF COMBUSTION AIR (NO LESS THAN 6 SQ. IN.) DUCTED TO EACH FIREBOX DIRECT VENT.

**ENERGY CONSERVATION**

**INSULATION AND VAPOR BARRIERS**

APPLICATION AND INSTALLATION OF INSULATION AND VAPOR BARRIERS SHALL COMPLY WITH WASHINGTON STATE THERMAL INSULATION STANDARDS. ALL INSULATING MATERIALS SHALL HAVE A FLAME SPREAD INDEX OF NOT MORE THAN 25 AND A SMOKE-DEVELOPED INDEX OF NOT MORE THAN 450 PER SECTION R302.10. EXTERIOR WINDOW AND DOOR HEADERS SHALL BE INSULATED WITH R-10 INSULATION.

**AIR LEAKAGE**

ALL EXTERIOR JOINTS SHALL BE SEALED, CAULKED, GASKETED, OR WEATHER-STRIPPED TO LIMIT AIR LEAKAGE IN THE FOLLOWING LOCATIONS:

- WINDOW AND DOOR FRAMES
- OPENINGS BETWEEN WALLS AND FOUNDATIONS
- BETWEEN WALLS AND ROOF OPENINGS AT PENETRATION OF UTILITY SERVICES
- ALL OTHER OPENINGS IN THE BUILDING

**ASSEMBLIES**

**R1 - TYPICAL VENTED ROOF/CEILING**

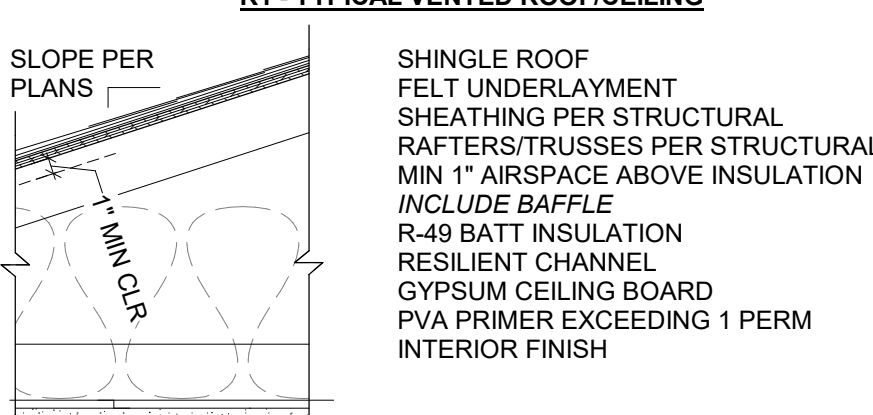

SHINGLE ROOF  
FELT UNDERLAYMENT  
SHEATHING PER STRUCTURAL  
RAFTERS/TRUSSES PER STRUCTURAL  
MIN 1" AIRSPACE ABOVE INSULATION  
INCLUDE BAFFLE  
R-49 BATT INSULATION  
RESILIENT CHANNEL  
GYPSUM CEILING BOARD  
PVA PRIMER EXCEEDING 1 PERM  
INTERIOR FINISH

**W21 - TYPICAL EXTERIOR WALL**

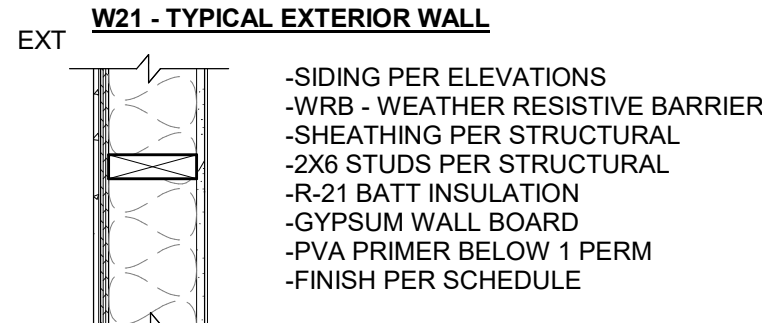

-SIDING PER ELEVATIONS  
-WRB - WEATHER RESISTIVE BARRIER  
-SHEATHING PER STRUCTURAL  
-2X6 STUDS PER STRUCTURAL  
-R-21 BATT INSULATION  
-GYPSUM WALL BOARD  
-PVA PRIMER BELOW 1 PERM  
-FINISH PER SCHEDULE

**W2 - TYPICAL INTERIOR PARTITION**

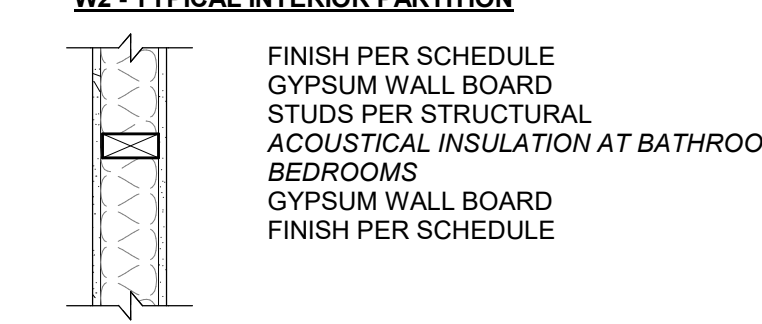

FINISH PER SCHEDULE  
GYPSUM WALL BOARD  
STUDS PER STRUCTURAL  
ACOUSTICAL INSULATION AT BATHROOMS AND BEDROOMS  
GYPSUM WALL BOARD  
FINISH PER SCHEDULE

**W6 - TYPICAL INTERIOR SHEAR WALL**

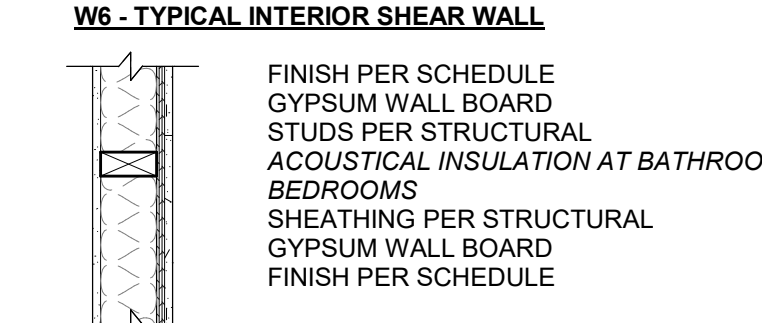

FINISH PER SCHEDULE  
GYPSUM WALL BOARD  
STUDS PER STRUCTURAL  
ACOUSTICAL INSULATION AT BATHROOMS AND BEDROOMS  
SHEATHING PER STRUCTURAL  
GYPSUM WALL BOARD  
FINISH PER SCHEDULE  
NOTE: OMIT GYP AT CRAWLSPACE

**W5 - TYPICAL INTERIOR GARAGE WALL**

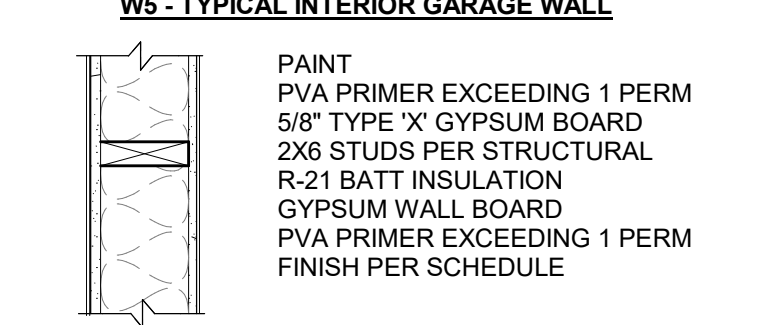

PAINT  
PVA PRIMER EXCEEDING 1 PERM  
5/8" TYPE 'X' GYPSUM BOARD  
2X6 STUDS PER STRUCTURAL  
R-21 BATT INSULATION  
GYPSUM WALL BOARD  
PVA PRIMER EXCEEDING 1 PERM  
FINISH PER SCHEDULE

**W7 - TYPICAL INTERIOR GARAGE SHEAR WALL**

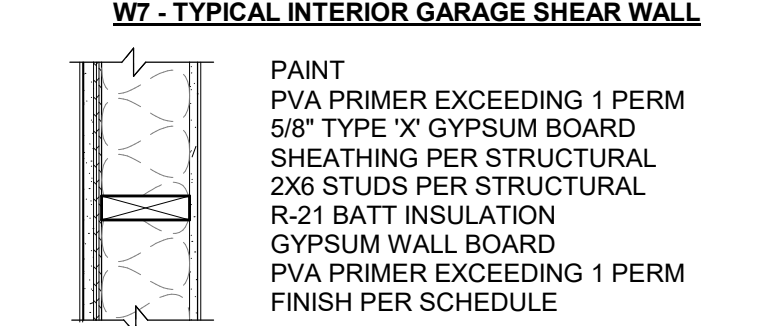

PAINT  
PVA PRIMER EXCEEDING 1 PERM  
5/8" TYPE 'X' GYPSUM BOARD  
SHEATHING PER STRUCTURAL  
2X6 STUDS PER STRUCTURAL  
R-21 BATT INSULATION  
GYPSUM WALL BOARD  
PVA PRIMER EXCEEDING 1 PERM  
FINISH PER SCHEDULE

**W3 - TYPICAL FOUNDATION WALL**

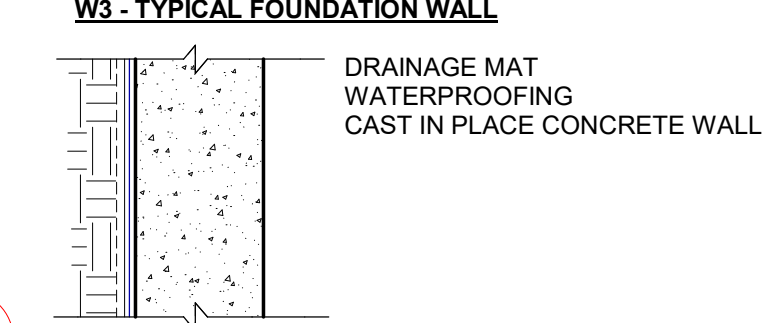

DRAINAGE MAT  
WATERPROOFING  
CAST IN PLACE CONCRETE WALL

**G1 - TYPICAL GARAGE FLOOR**

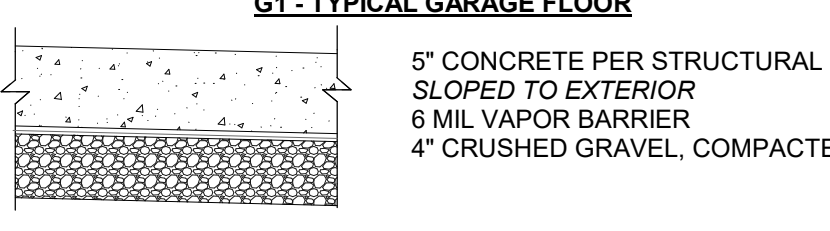

5" CONCRETE PER STRUCTURAL  
SLOPED TO EXTERIOR  
6 MIL VAPOR BARRIER  
4" CRUSHED GRAVEL, COMPACTED

**P1 - TYPICAL PORCH/PATIO FLOOR**

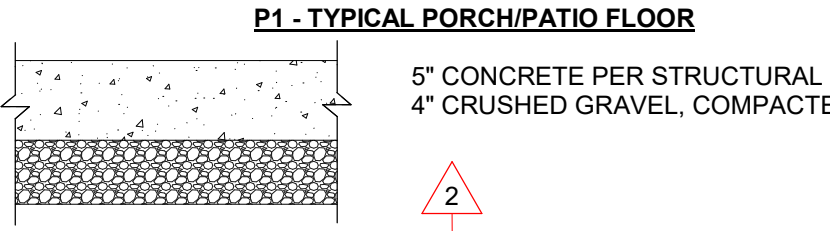

5" CONCRETE PER STRUCTURAL  
4" CRUSHED GRAVEL, COMPACTED

**F5 - TYPICAL DECK**

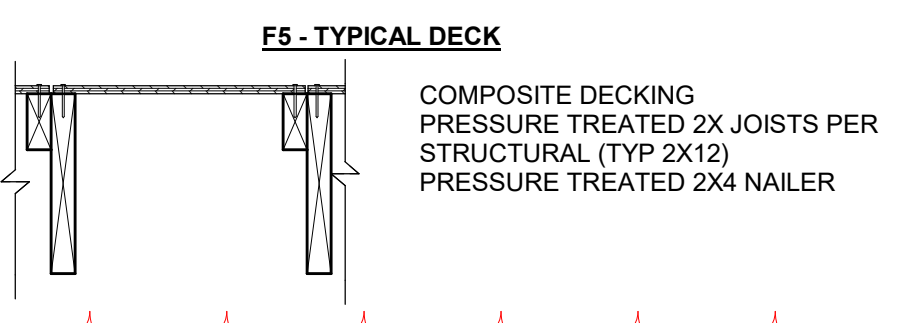

COMPOSITE DECKING  
PRESSURE TREATED 2X JOISTS PER STRUCTURAL (TYP 2X12)  
PRESSURE TREATED 2X4 NAILER

**DRAWING TITLES**

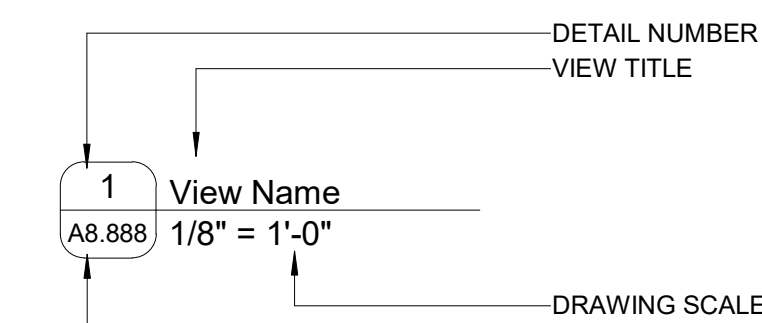

**VIEW MARKERS**

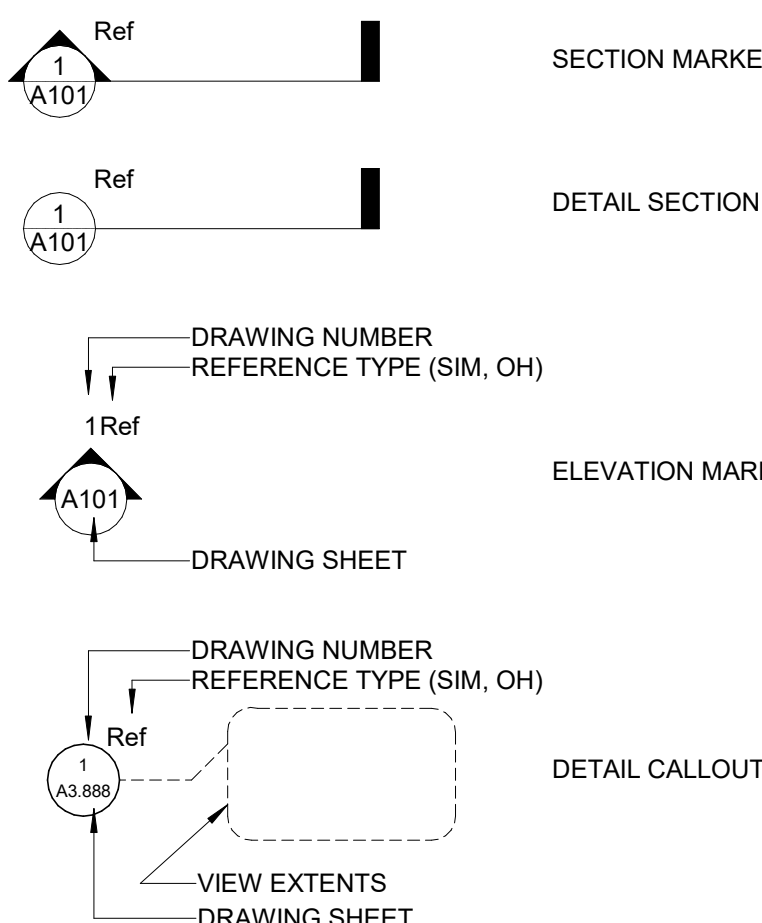

**DRAWING SYMBOLS**

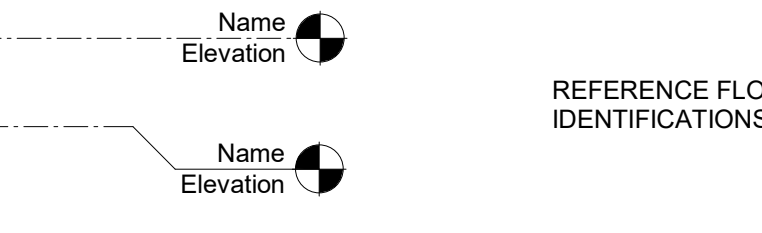

**ITEM TAGS**

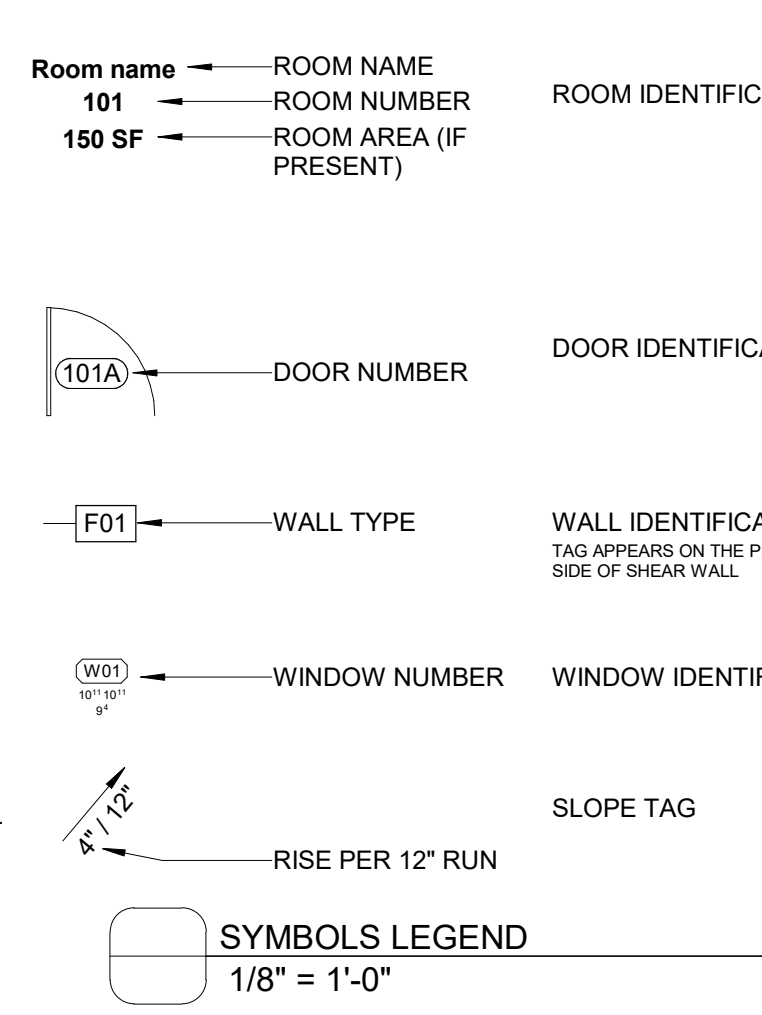

SYMBOLS LEGEND  
1/8" = 1'-0"



3009 112th Ave NE, Suite 100  
Bellevue, WA 98004  
T (425) 429-6645  
F (888) 224-0299  
mncustom.com  
copyright © 2022

CONSULTANT

STAMP

MN NO.

MN472

PROJECT GENERAL INFORMATION

7119 80TH AVE SE

MERCER ISLAND, WA 98040

PROJECT GENERAL INFORMATION

**REVISION HISTORY**

Δ	DATE	SUBMISSION
---	------	------------

2 02-01-2024 REV 2

DATE: 04-12-2024

SCALE: AS NOTED

SET TYPE: PERMIT

SHEET NUMBER A0.1





3009 112th Ave NE, Suite 100  
Bellevue, WA 98004  
T (425) 429-6645  
F (888) 224-0299  
mhcustom.com  
copyright © 2022

CONSULTANT

STAMP

MIN NO.

**MN472**

**7119 80TH AVE SE  
MERCER ISLAND, WA 98040**

**ENERGY CODE COMPLIANCE**

REVISION HISTORY

△ DATE SUBMISSION

DATE: 04-12-2024

SCALE: AS NOTED

SET TYPE: PERMIT

SHEET NUMBER

**A0.2**

**Project Information**  
7119 80TH AVE SE  
MERCER ISLAND, WA 98040

**Contact Information**

**Messages / Results \***  
UA Reduction = 9.43, Proposed UA is better than baseline by 2%.

Whole House Mechanical Ventilation Airflow Rate: 123.5 CFM with Run Time Percent of 75%, Balanced, Distributed  
Maximum allowable total measured duct leakage: 148 CFM25

**RESULTS - Comparison of Baseline and Proposed Design**

Component	Baseline		Proposed Design	
	U	UA	U	UA
Doors U	0.300	96	0.300	96
Overhead Glazing U	0.300	0	0	0.0
Vertical Glazing U	0.300	633	0.027	189.9
Fuel/Ventilated Ceilings U	0.027	2,740	0.027	740
Wall (above grade) U	0.056	4,715	0.054	284.0
Floors over Crawlspace U	0.029	2,204	0.029	63.9
Slab on Grade F	0.540	0	0	0.0
Below Grade Wall F	0.540	0	0	0.0
Below Grade Slab F	0.570	0	0	0.0
<b>Baseline UA Total</b>		<b>620.1</b>		<b>611.2</b>
<b>Proposed UA Total</b>		<b>6.0</b>		<b>6.0</b>
<b>Required Credits</b>		<b>6.0</b>		<b>6.0</b>
<b>UA Percent Reduction</b>		<b>1.9%</b>		<b>1.9%</b>
<b>UA Reduction</b>		<b>9.4</b>		<b>9.4</b>

**Table R406.2 Fuel Normalization Credits**

System No.	Full Description	Select System Type	Fuel Normalization Credits (406.2)	Energy Credits (406.3)	Total Credits (406.2 & 406.3)
1	Combustion heating equipment meeting minimum federal efficiency standards for the equipment listed in Table C403.3.2(4) or C403.3.2(5)	Min Federal Efficiency System	0.0	6.0	6.0

**Table R406.3 Energy Credits**

Option No.	Category	Select Options	Energy Credits	Brief Description of Selected Options*
1	Efficient Building Envelope	Not Selected	0.0	
2	Air Leakage Control and Efficient Ventilation	Not Selected	0.0	
3	High Efficiency HVAC	Option 3.1	1.0	High Efficiency Fossil fuel-fired furnace or boiler as primary heating system (Min AFUE 90% for furnace or 90% for boiler)
4	High Efficiency HVAC Distribution System	Not Selected	0.0	
5.1	Efficient Water Heating	Not Selected	0.0	
5.2-5.6	Efficient Water Heating	Option 5.5	2.0	NEA Tier 3 heat pump water heater
6	Renewable Electric Energy	Option 6.1	3.0	On-site wind or solar electric energy
7	Appliance Package	Not Selected	0.0	
	<b>Energy Credits</b>		<b>6.0</b>	

\*Refer to WSEC 2018 Table R406.3 for complete option descriptions and requirements

**THERMAL ENVELOPE DETAILS - Proposed Design**

MN472.xlsx 7/27/2023

Plan ID	Component Description	Ref.	U	Area	UA
	R21 cavity/R9 foam MT 2X6W Lap (Code Baseline)		0.054	4,715	285
	<b>Sum of Area and UA</b>			<b>4,715</b>	<b>285</b>

**Floor (over crawl or exterior)**

Plan ID	Component Description	Ref.	Floor U	Area	UA
	R39 vented Joist 16oc (Code Baseline)		0.029	2,204	64
	<b>Sum of Area and UA</b>			<b>2,204</b>	<b>64</b>

**Slab on Grade (less than 2 feet below grade)**

Plan ID	Component Description	Ref.	Slab F	Area	FP
	<b>Sum of Perimeter and FP</b>			<b>0</b>	<b>0</b>

**Below Grade Walls and Slabs**

Plan ID	Component Description	Ref.	Wall U	Area	UA	Slab F	Slab Perim	Slab UA
	<b>Sum of Area, Length and UA</b>			<b>0</b>	<b>0.0</b>		<b>0</b>	<b>0</b>

**Ventilation Requirements**

Number of Bedrooms	5
Run-Time Percent in Each 4-Hour Segment	75%
Is the system Balanced?	Yes
Is the system Distributed?	Yes
Ventilation Code Section	IRC, Chapter 15
Whole House Mechanical Ventilation Airflow Rate	124 CFM

**HVAC Thermal Distribution System**

Is this a hydronic heating system?	No
Location of Air Handler	Unconditioned Space
Existing Construction: Are Any of These Exceptions True?	
Are ducts systems documented to have been previously sealed as confirmed through field verification and diagnostic testing per RES-307?	No
Is there less than 40 linear feet in unconditioned spaces?	No
Are existing duct systems constructed, insulated or sealed with asbestos?	No
Is the project an Addition less than 750 of conditioned floor area?	No
Is Duct Testing Required? Yes	
Maximum Duct Leakage: Is this a post-construction test?	No
Is the air handler "resized"?	No
Maximum total measured duct leakage per square foot	0.03 CFM25 per sq. ft.
Maximum allowable total measured duct leakage	148 CFM25

**Links to Download Forms, Checklists and Other Resources**

Compliance Certificate	Compliance Certificate	Instructions
Insulation Certificate for Residential New Construction	Insulation Certificate	
Duct Testing Affidavits	Affidavit, Existing	Affidavit, New
Prescriptive Checklist for 2018 WSEC	Prescriptive Checklist	
Alterations (Remodel) Worksheet	Worksheet	

MN472.xlsx 7/27/2023

Conditioned Floor Area, Proposed Design: 4,944 sq. ft.  
Classification: Medium Dwelling Unit

**Exterior Doors**

Plan ID	Component Description	Ref.	Door U	Area	UA
	Code Baseline, U=0.30		0.30	1	0.30
	Code Baseline, U=0.30		0.30	1	0.30
	Code Baseline, U=0.30		0.30	1	0.30
	Code Baseline, U=0.30		0.30	1	0.30
	<b>Sum of Area and UA (including exempt door)</b>			<b>96</b>	<b>28.8</b>
	<b>Exterior Doors Area Weighted U</b>				<b>0.300</b>

**Overhead Glazing**

Plan ID	Component Description	Ref.	Glazing U	Area	UA
	<b>Sum of Area and UA</b>			<b>0</b>	<b>0</b>
	<b>Overhead Glazing Area Weighted U</b>				<b>0</b>

**Vertical Glazing Schedule**

Plan ID	Component Description	Ref.	Glazing U	Area	UA
	Exempt				
1	U=0.30 (Code Baseline)	Table A9.2	0.30	3	0.90
2	U=0.30 (Code Baseline)	Table A9.2	0.30	1	0.30
3	U=0.30 (Code Baseline)	Table A9.2	0.30	2	0.60
4	U=0.30 (Code Baseline)	Table A9.2	0.30	2	0.60
5	U=0.30 (Code Baseline)	Table A9.2	0.30	1	0.30
6	U=0.30 (Code Baseline)	Table A9.2	0.30	1	0.30
7	U=0.30 (Code Baseline)	Table A9.2	0.30	4	1.20
8	U=0.30 (Code Baseline)	Table A9.2	0.30	5	1.50
9	U=0.30 (Code Baseline)	Table A9.2	0.30	2	0.60
10	U=0.30 (Code Baseline)	Table A9.2	0.30	1	0.30
11	U=0.30 (Code Baseline)	Table A9.2	0.30	5	1.50
12	U=0.30 (Code Baseline)	Table A9.2	0.30	2	0.60
13	U=0.30 (Code Baseline)	Table A9.2	0.30	2	0.60
14	U=0.30 (Code Baseline)	Table A9.2	0.30	2	0.60
15	U=0.30 (Code Baseline)	Table A9.2	0.30	3	0.90
16	U=0.30 (Code Baseline)	Table A9.2	0.30	3	0.90
17					
18					
19					
	<b>Sum of Area and UA</b>			<b>632.9</b>	<b>189.9</b>
	<b>Vertical Glazing Area Weighted U</b>				<b>0.300</b>
	<b>Vertical Glazing and Doors Area Weighted U</b>				<b>0.300</b>

**Fuel/Ventilated Ceilings**

Plan ID	Component Description	Ref.	Attic U	Area	UA
	R49 Insulated Attic STD baffled (Code Baseline, Option 1.1.1.4)	R9.7	0.027	2,740	74.0
	<b>Sum of Area and UA</b>			<b>2,740</b>	<b>74.0</b>

**Walls (Above Grade)**

Plan ID	Component Description	Ref.	Wall U	Area	UA
	<b>Sum of Area and UA</b>			<b>2,740</b>	<b>74.0</b>

MN472.xlsx 7/27/2023

**Heating System Sizing - Proposed Design**

Try Our BetterBuildItWV's HVAC Sizing Tool: <https://betterbuilditwv.com/resources/hvac-sizing-tool/>

Nearest Weather Station: Mercer Island

Indoor Design Temperature: 70 F

Outdoor Design Temperature: 25 F

Design Temperature Difference (ΔT): 45 F

Conditioned Floor Area, Proposed Design: 4,944 sq. ft.

Conditioned Volume: 41,737 cu. ft.

HVAC System Type: All Other Systems (not heat pump)

Location of HVAC Distribution System: Unconditioned Space

Sum of UA, including exempt door and window: 618

Envelope Heat Load: 27,827 Btu / Hour

Air Leakage Heat Load: 20,294 Btu / Hour

Building Design Heat Load: 48,121 Btu / Hour

Building and Duct Heat Load: 52,833 Btu / Hour

Maximum Heat Equipment Output: 74,187 Btu / Hour

MN472.xlsx 7/27/2023

- ENERGY CODE NOTES**
- POST WSEC COMPLIANCE WITHIN 3 FEET OF ELECTRICAL PANEL
  - REFER TO A0.1 FOR ASSEMBLY R-VALUES
  - REFER TO A0.1 FOR ADDITIONAL NOTES FOR MECHANICAL AND PLUMBING SYSTEMS
  - REFER TO A0.5 AND A0.6 DOOR AND WINDOW SCHEDULE SHEETS
  - CLIMATE ZONE 4C
  - POST INSULATION CERTIFICATE FOR RESIDENTIAL CONSTRUCTION WITHIN 36" OF ELECTRICAL PANEL
  - THE BUILDING ENVELOPE SHALL BE CONSTRUCTED TO LIMIT AIR LEAKAGE PER R402.4.1-R402.4.4
  - PROVIDE AT LEAST ONE THERMOSTAT FOR EACH SEPARATE HEATING AND COOLING SYSTEM
  - AT SOLAR READY ZONE AVOID ROOF PENETRATIONS. SEE ROOF PLAN FOR ADDITIONAL NOTES

- ENERGY CODE COMPLIANCE**
- 2018 WASHINGTON STATE RESIDENTIAL ENERGY CODE  
**PRESCRIPTIVE APPROACH USED.** PRESCRIPTIVE OPTION, PER WSEC R402.1, WILL BE USED TO DETERMINE REQUIRED U-VALUES AND R-VALUES FOR THE ADDITION. (NOTE: BOLD TEXT INDICATES MODIFICATION FROM MINIMUM PRESCRIPTIVE REQUIREMENTS)
- VERTICAL PENETRATION U-FACTOR .30
  - UP TO 15 SF EXEMPT PER R402.3.3
  - SKYLIGHT U-FACTOR: .50
  - MAXIMUM OPAQUE WOOD DOOR U-FACTOR: .30
  - ONE 24 SF OPAQUE DOOR EXEMPT PER R402.3.4
  - REQUIRED R-VALUE FOR CEILINGS: R-49 MIN. R-38C SINGLE RAFTER/VAULTS
  - REQUIRED R-VALUE FOR WALLS ABOVE GRADE: R-21 MIN.
  - REQUIRED R-VALUE FOR FLOORS: R-30
  - REQUIRED R-VALUE FOR SLAB ON GRADE: R-10, 2" MIN

**R404.1 - INTERIOR LIGHTING**  
A MINIMUM OF 90% OF LAMPS IN PERMANENTLY INSTALLED LIGHTING FIXTURES SHALL BE HIGH EFFICACY LAMPS R404.1

**TABLE R406.3 - ADDITIONAL ENERGY EFFICIENCY REQUIREMENTS**  
2. MEDIUM DWELLING UNIT, ALL DWELLING UNITS THAT ARE NOT INCLUDED IN #1 OR #3.  
**6 CREDITS REQUIRED**

- SELECTED OPTIONS:**
- HEATING OPTIONS**  
OPTION 2 (0.0 CREDIT) GAS FURNACE
- ENERGY OPTIONS**  
OPTION 3.1 (1.0 CREDIT) GAS FURNACE  
OPTION 5.5 (2.0 CREDITS) EFFICIENT WATER HEATING  
OPTION 6.1 (3.0 CREDITS) RENEWABLE ENERGY  
**TOTAL CREDITS = 6**

**WORKSHEET NOTES**  
**3.1 - HIGH EFFICIENCY HVAC**  
BASIS OF DESIGN OR EQUAL: TRANE S9X1 SINGLE STAGE FAU

**5.5 - EFFICIENT WATER HEATING**  
TIER III WITH W/EXT COMPRESSOR: 2.0 CREDITS  
BASIS OF DESIGN OR EQUAL: 80 GAL RHEEN ELECTRIC HEAT PUMP WATER HEATER: MODEL #PROPH80-T2-RH350D; EFF=3.70

**6.1 - RENEWABLE ELECTRIC ENERGY - SEE A0.2**  
10x400 WATT PANELS = 3 CREDITS  
BASIS OF DESIGN OR EQUAL: SILFAB SOLAR 400

**BUILDING AREAS**

AREA TYPE	AREA
HEATED UPPER LEVEL	2296.94 SF
HEATED MAIN LEVEL	2200.82 SF
HEATED AREA	4497.76 SF
UNCOVERED REAR PATIO	206.88 SF
UNHEATED GARAGE	720.66 SF
COVERED FRONT PATIO	326.90 SF
COVERED SIDE PATIO	385.00 SF
UNHEATED AREA	1639.44 SF

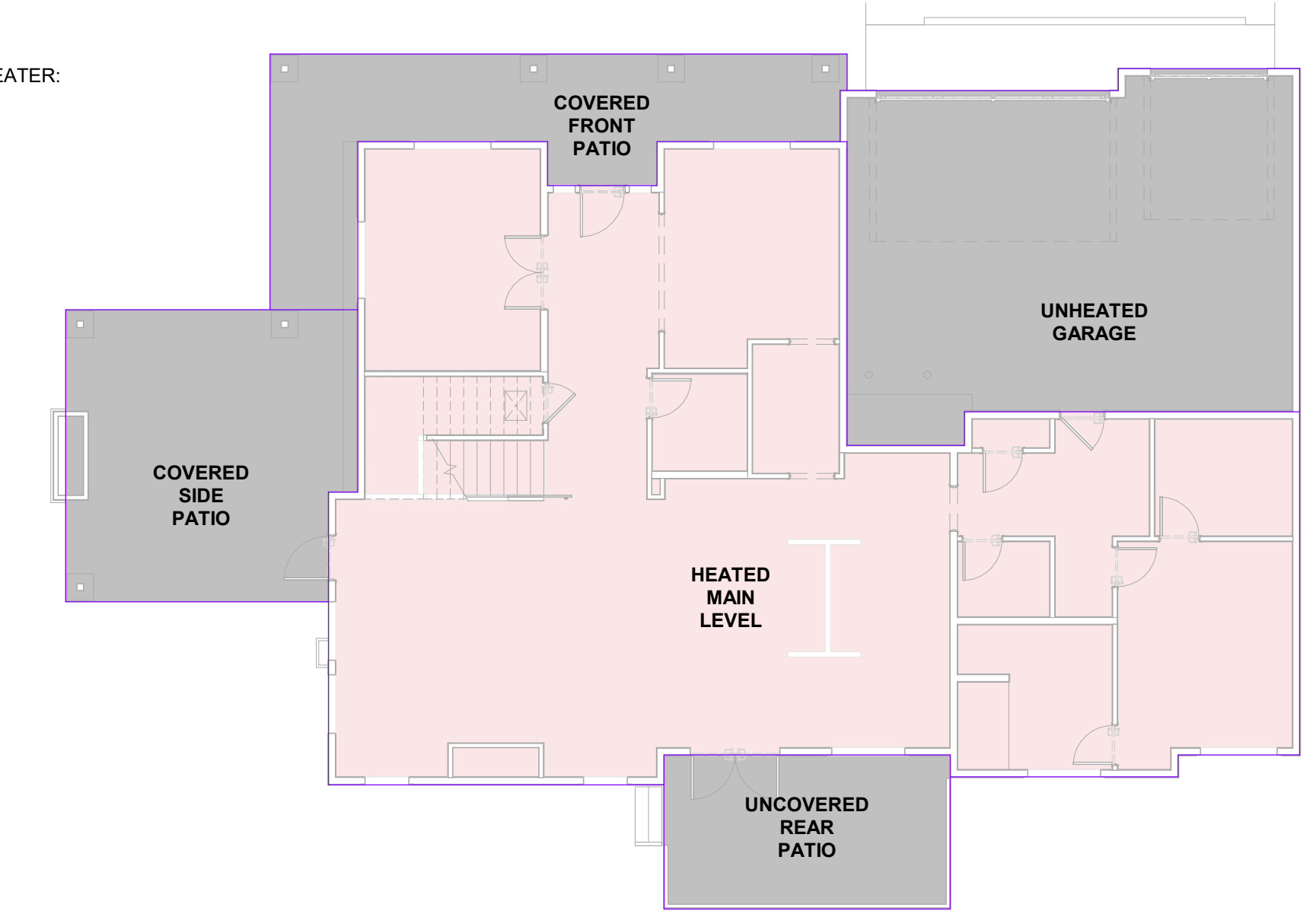

1 HEATED AREA MAIN LEVEL  
A0.2 1" = 10'-0"

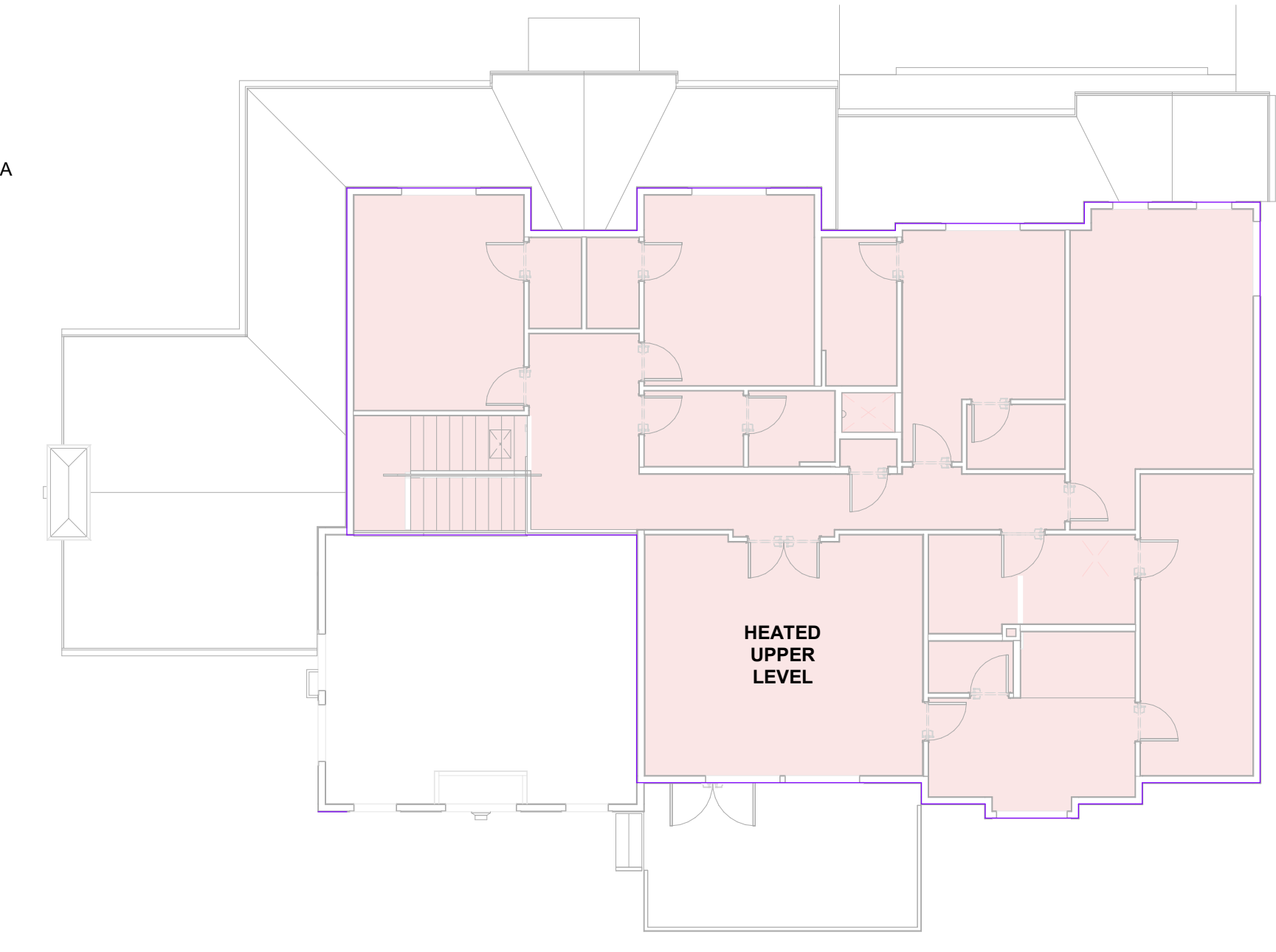

2 HEATED AREA UPPER LEVEL  
A0.2 1" = 10'-0"



**7119 80TH AVE SE  
 MERCER ISLAND, WA 98040  
 ZONING ANALYSIS AND DIAGRAMS**

REVISION HISTORY

Δ	DATE	SUBMISSION
2	02-01-2024	REV 2
3	03-18-2024	REV 3

DATE: 04-12-2024

SCALE: AS NOTED

SET TYPE: PERMIT

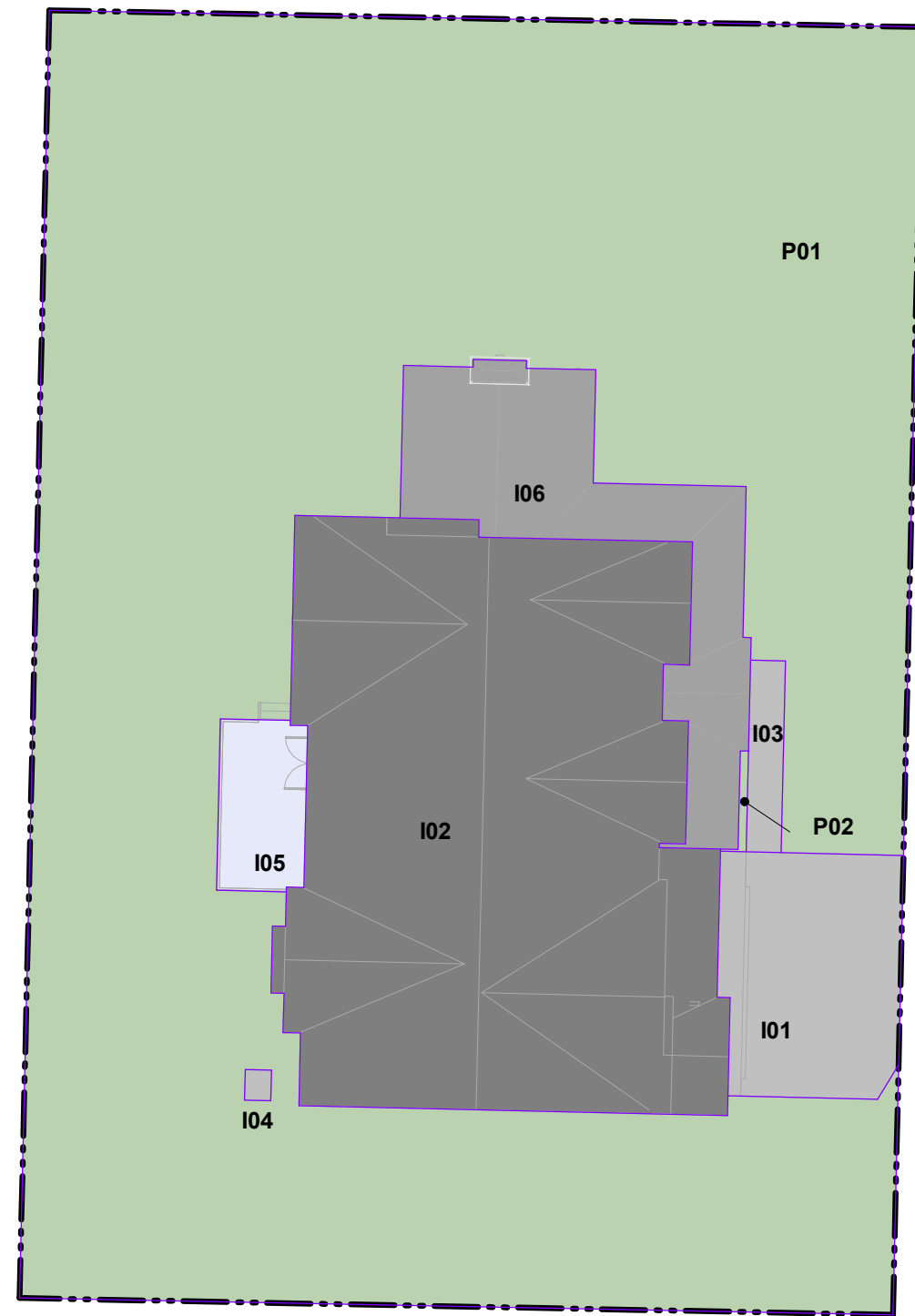

**A6 LOT COVERAGE**  
 A0.3 1" = 20'-0"

I03	WALKWAY	87.83 SF	0.6%
I04	EQUIPMENT PAD	10.50 SF	0.1%
I05	UNCOVERED PATIO	194.08 SF	1.3%
HARDSCAPE			
		292.42 SF	2.0%
I01	DRIVEWAY	565.34 SF	3.8%
I02	STRUCTURE WITH ROOF OVERHANG	3110.92 SF	21.1%
I06	COVERED PATIO	772.93 SF	5.2%
INCLUDED IN LOT COVERAGE			
		4449.19 SF	30.2%
P01	PERVIOUS	9999.73 SF	67.8%
P02	PERVIOUS	11.56 SF	0.1%
YARD		10011.29 SF	67.9%
TOTAL:		14752.90 SF	100.0%

LOT AREA: 14,753 SF  
 40% COVERAGE ALLOWABLE: 5,901 SF  
 PER 19.02.010.F.3

NOTE: LOT SLOPE IS < 15% (300.9' ÷ 292.2' = 8.7' / 147.53' = 0.05 → 5%)

**TOTAL IMPERVIOUS COMPLIES UNDER 40% COVERAGE**

- LEGEND**
- COVERED PATIO
  - DRIVEWAY
  - EQUIPMENT PAD
  - PERVIOUS
  - STRUCTURE WITH ROOF OVERHANG
  - UNCOVERED PATIO
  - WALKWAY

MAIN LEVEL			
L1D	2-STORY STAIR	109.82 SF	2%
L1B	CEILING HEIGHT @ 20'	442.15 SF	8%
L1C	GARAGE	715.65 SF	13%
L1A	LEVEL 1	1662.91 SF	30%
MAIN LEVEL: 4		2930.53 SF	53%
UPPER LEVEL			
L2B	CEILING HEIGHT @ 20'	461.92 SF	8%
L2A	LEVEL 2	2173.06 SF	39%
UPPER LEVEL: 2		2634.98 SF	47%
		5565.50 SF	100%

LOT AREA: 14,753 SF  
 40% COVERAGE ALLOWABLE: 5,901 SF  
**COMPLIES, 5,566 < 5,901**

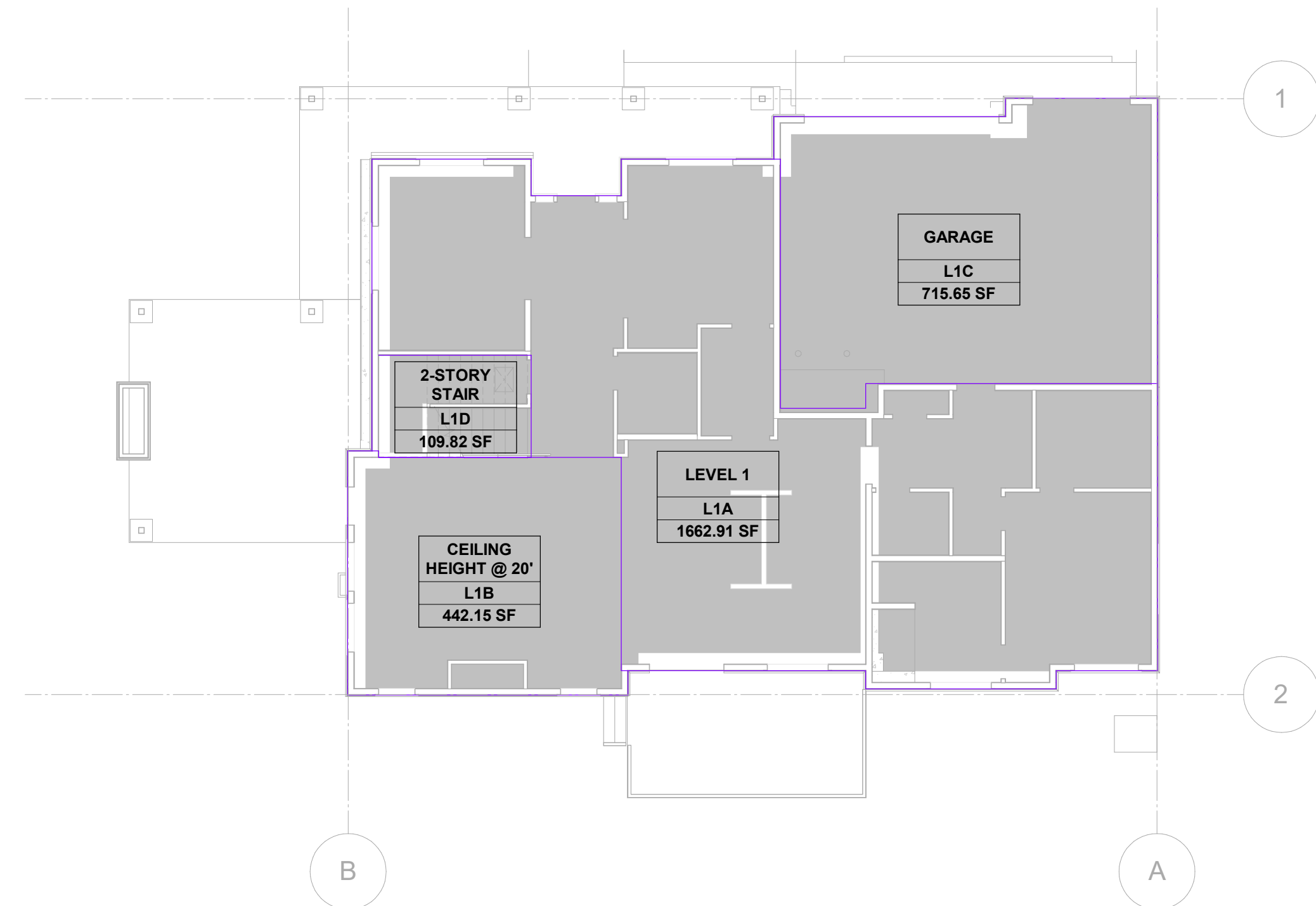

**A3 GROSS FLOOR AREAS- MAIN LEVEL**  
 A0.3 1" = 10'-0"

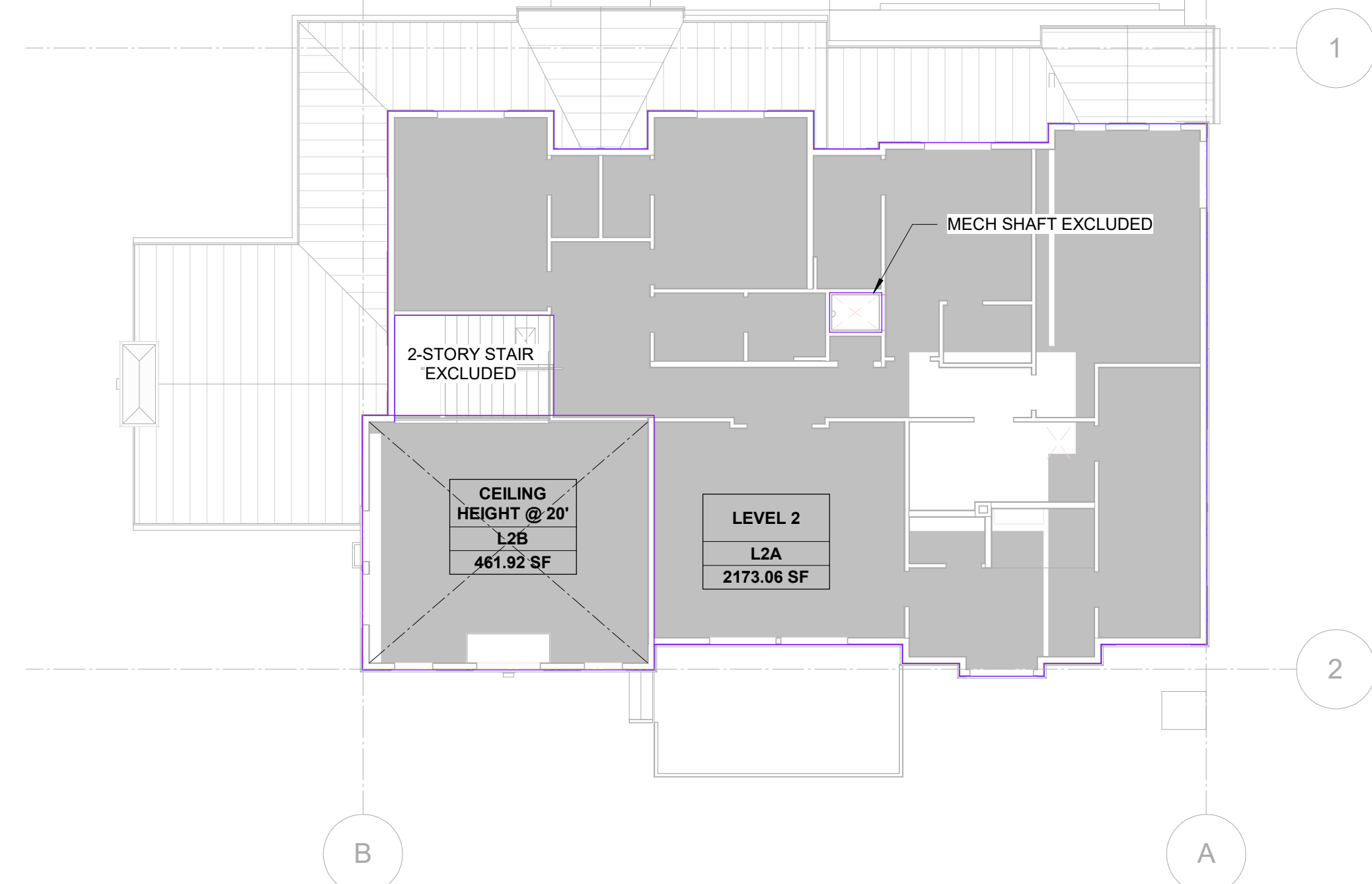

**A2 GROSS FLOOR AREAS- UPPER LEVEL**  
 A0.3 1" = 10'-0"

AVERAGE EXISTING GRADE	
A	297.863
B	297.674
C	297.425
D	296.865
E	296.708
F	296.608
G	296.568
H	296.479
I	296.342
J	296.434
K	292.508
L	296.53
M	295.574
N	296.232
O	296.508

**NUMBER OF SPOT GRADES, AVERAGE EXISTING GRADE, MAX BUILDING HEIGHT:**

COUNT	AVG ELEV	MAX HT
15	296.4212	326.4212

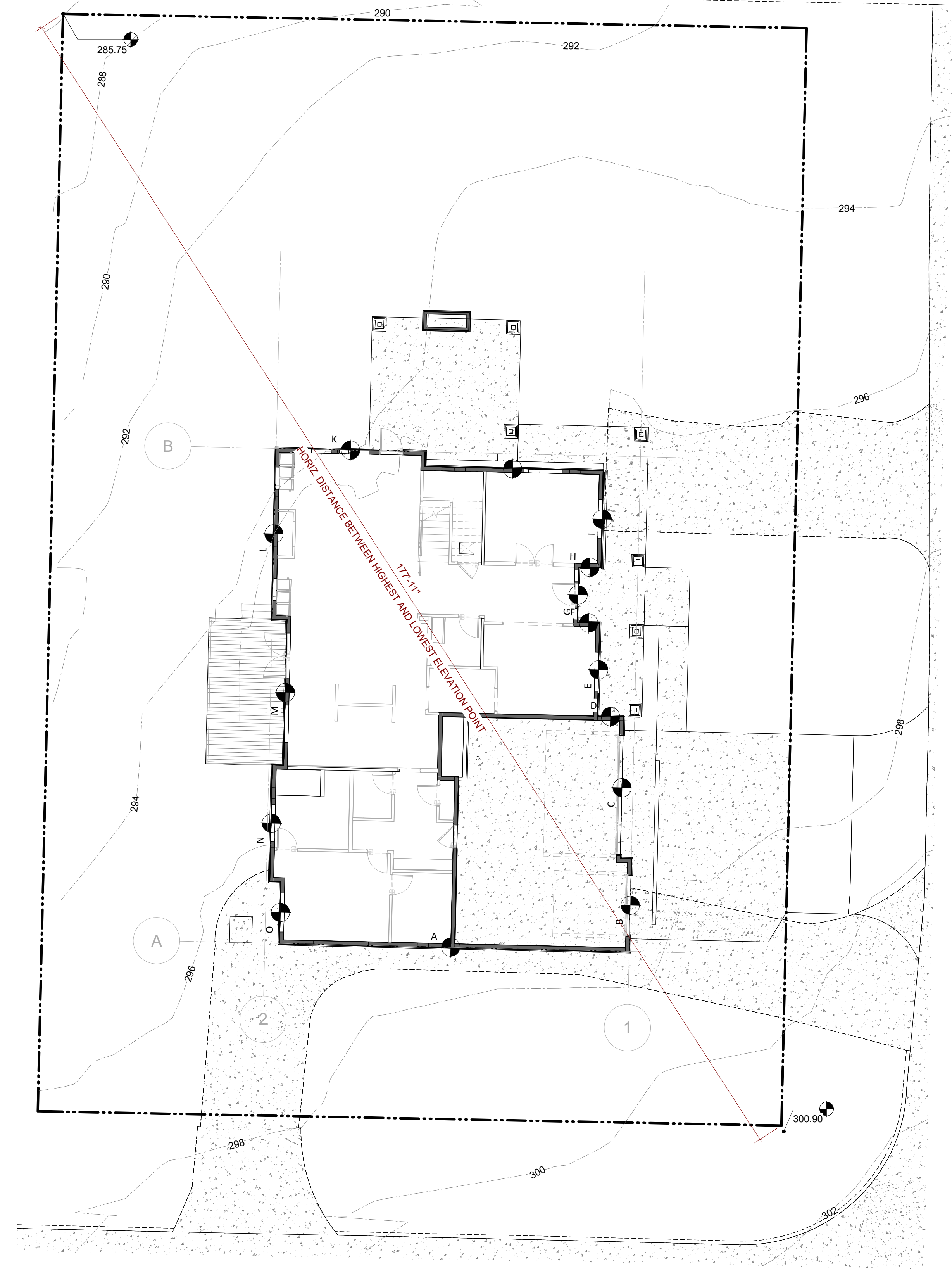

**A1 AVERAGE EXISTING GRADE**  
 A0.3 1" = 10'-0"

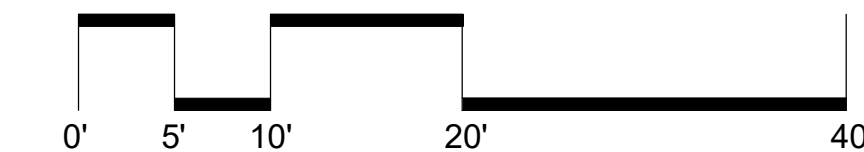











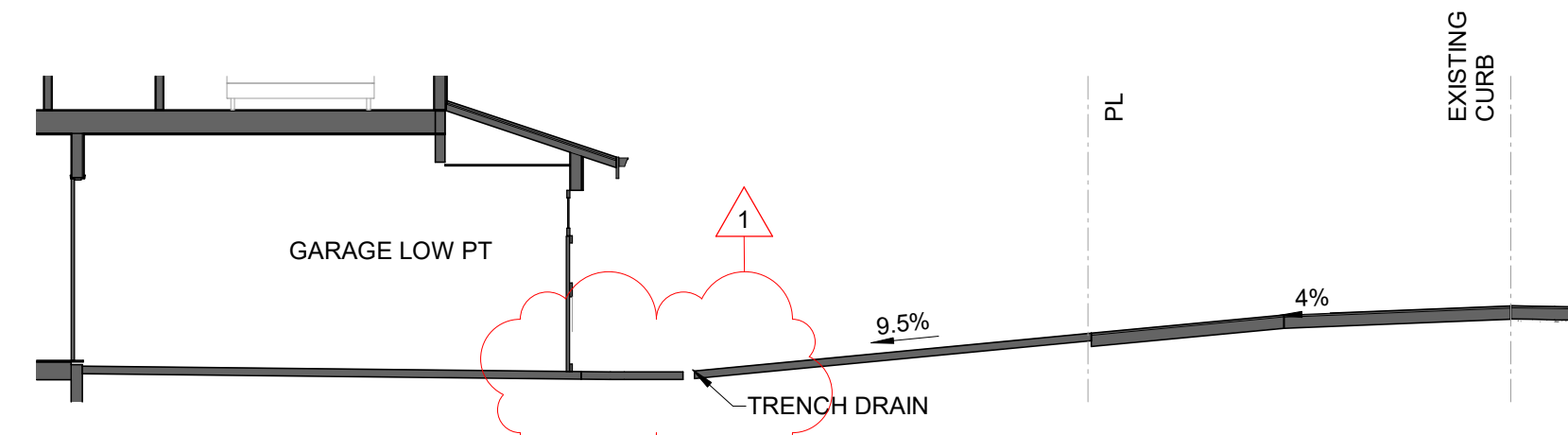

3 DRIVEWAY SECTION  
A1.1 1/8" = 1'-0"

ALL TREES					
TREE #	TREE SPECIES	TRUNK DIAMETER	TREE STATUS	TREE - ON PROPERTY	>24"
2	DEC	6"	RETAINED	Yes	No
3	DEC	10"	RETAINED	Yes	No
5	DEC	6"	RETAINED	Yes	No
6	FIR	22"	RETAINED	Yes	No
7	DEC	6"	REMOVED	Yes	No
8	DEC	12"	RETAINED	Yes	No
9	DEC	16"	RETAINED	Yes	No
10	DEC	6"	RETAINED	Yes	No
11	DEC	6"	RETAINED	Yes	No
12	DEC	10"	RETAINED	Yes	No
13	FIR	24"	RETAINED	Yes	Yes
14	FIR	18"	RETAINED	Yes	No
19	DEC	8"	RETAINED	Yes	No
26	CED	2"	NEW	Yes	No
27	CED	2"	NEW	Yes	No
28	CED	2"	NEW	Yes	No
29	CED	2"	NEW	Yes	No
29	FIR	22"	RETAINED	No	No
29	FIR	26"	RETAINED	No	Yes
4	HLY	6"	RETAINED	No	No
16	MAP	22"	RETAINED	No	No
17	FIR	18"	RETAINED	No	No
18	FIR	38"	RETAINED	No	Yes
20	FIR	28"	RETAINED	No	Yes
21	FIR	16"	RETAINED	No	No
22	FIR	28"	RETAINED	No	Yes
23	FIR	26"	REMOVED	No	Yes
24	FIR	18"	RETAINED	No	No
25	FIR	36"	RETAINED	No	Yes
29		442"			
29		442"			

**TREE LEGEND**

- TREE TO BE REMOVED
- TREE TO BE RETAINED
- NEW TREE

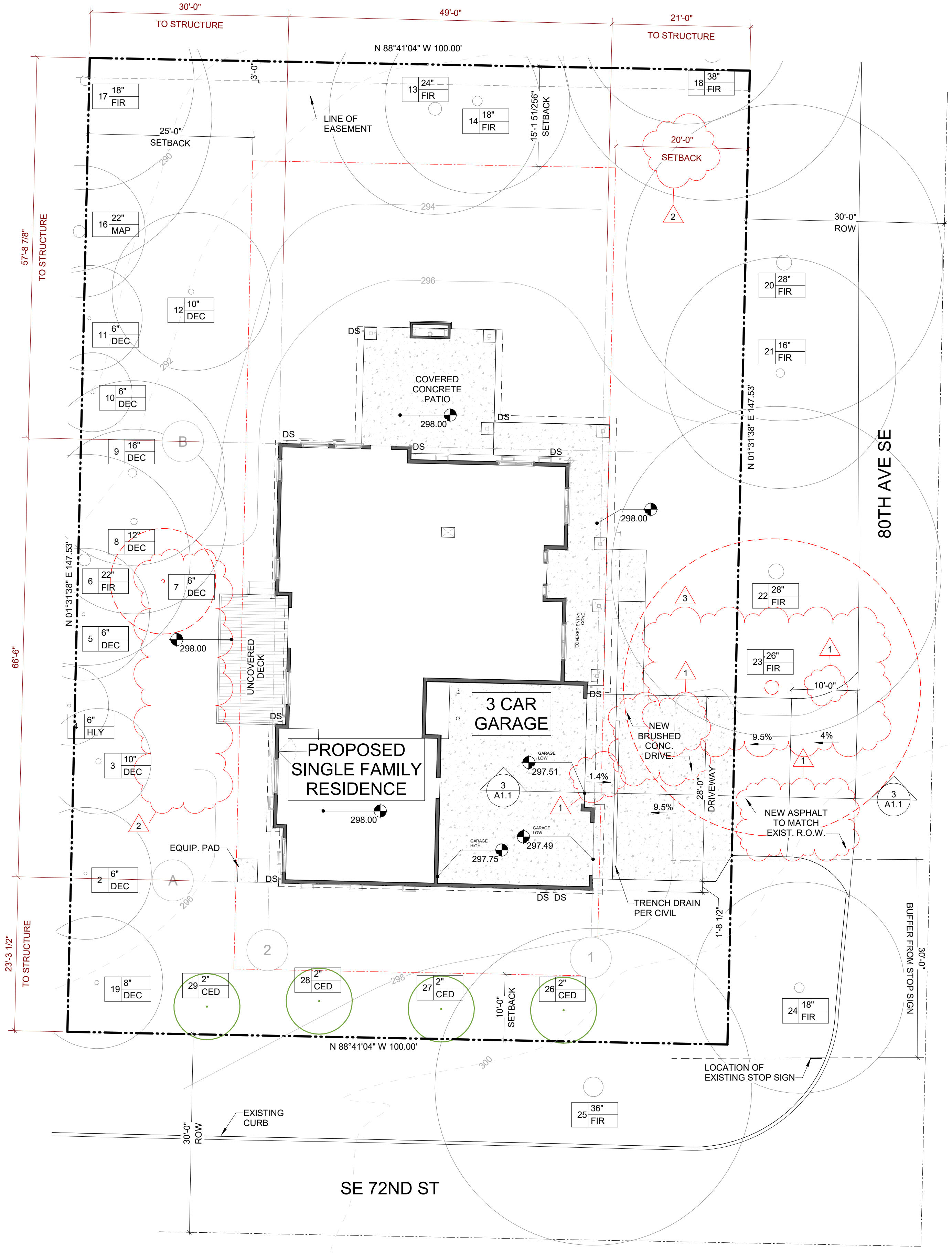

2 ARCHITECTURAL SITE PLAN  
A1.1 1" = 10'-0"

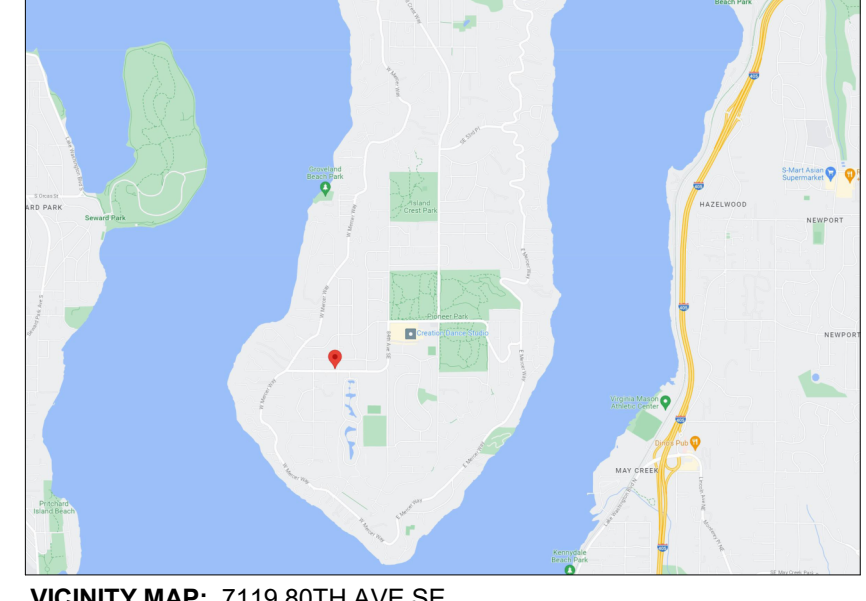
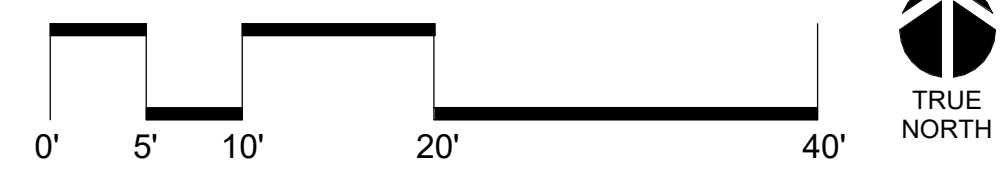

VICINITY MAP: 7119 80TH AVE SE

**NFPA 13D SPRINKLER SYSTEM REQUIRED**

**SITE PLAN GENERAL NOTES**

- REFER TO SURVEY
- REFER TO CIVIL SERIES FOR EROSION, PROPOSED STORM AND UTILITY CONNECTIONS, DRAINAGE DESIGN.
- UNDER SEPARATE PERMIT BY GC, DEMOLISH EXISTING RESIDENCE, CONCRETE DRIVEWAY, SHED/GUT/BUILDINGS.
- WORK COMPLETED WITHIN RIGHT OF WAY SHALL BE PER JURISDICTION CONSTRUCTION ROADWAY DESIGN STANDARDS. REFER TO CIVIL

**SITE PLAN NOTES TO REVIEWER**

THE ARCHITECTURAL SITE PLAN DOCUMENTS REQUIRED SITE PLAN ITEMS OF AN ARCHITECTURAL NATURE INCLUDING: PROPOSED BUILDING TYPE/LOCATION ON SITE, AVERAGE GRADE (WHICH DEVELOPS MAX BUILDING HEIGHT IN SECTIONS/ELEVATION), DRIVEWAY PROFILE, GREENSPACE (WHERE REQ'D), LOT COVERAGES, IMPERVIOUS COVERAGE, HOUSE MAIN LEVEL ELEVATION, FAR, TREE CALCULATIONS

THE CIVIL SITE PLAN DOCUMENTS DESIGN ASPECTS WHICH SUPPORT THE ARCHITECTURE AND PROPOSED BUILDING: UTILITY LOCATIONS AND CONNECTIONS, TRENCHING AND ROADWAY DESIGN, EROSION CONTROL, CURB AND SIDEWALK DESIGN, STORM CONNECTIONS, SITE DRAINAGE, WASTE/SEWER CONNECTIONS, TREE PROTECTION, CUT/FILL CALCS, RETAINING WALL DESIGN AND HEIGHTS, FULL EXTENT OF WORK IN ROW.

THERE ARE OVERLAPS WITHIN THE DOCUMENTATION OF CIVIL AND ARCHITECTURAL SITE PLANS. BOTH TEAMS SHOW THE FOLLOWING DOCUMENTATION: DRIVEWAY DESIGN/SLOPING/DIMENSIONING, EXISTING AND NEW TOPOGRAPHY, ZONING SETBACKS, CC&R SETBACKS, CRITICAL AREA DELINEATION, EASEMENTS

**PROJECT INFORMATION**

**OWNER**  
HOME PROJECT 472, LLC  
3009 112TH AVE NE, SUITE 100, BELLEVUE, WA 98004

**OWNER CONTACT**  
ERIC SADLER  
425.429.6645  
ESADLER@MNCUSTOM.COM

**SITE ADDRESS** 7119 80TH AVE SE  
MERCER ISLAND, WA 98040  
915970-0050  
**PARCEL** R-9-B  
**JURISDICTION** MERCER ISLAND  
**PRESENT USE** SINGLE FAMILY RESIDENTIAL  
**PROPOSED USE** SINGLE FAMILY RESIDENTIAL  
**LOT AREA** 14,753 SF (34 ACRES)  
**LEGAL DESCRIPTION** LOT 6, BLOCK 2, WAMBA'S FIRST ADDITION TO MERCER ISLAND ACCORDING TO THE PLAT THEREOF RECORDED IN VOLUME 55 OF PLATS, PAGE 54; RECORDS OF KING COUNTY, WASHINGTON SITUATED IN THE COUNTY OF KING, STATE OF WASHINGTON.

**DEVELOPMENT INFORMATION**  
REFER TO SITE PLAN FOR DOCUMENTATION RELATING TO LOT COVERAGE, FAR, GREENSPACE, IMPERVIOUS AREA, AVERAGE GRADE CALCULATION, DRIVEWAY

**PROJECT TEAM**

**OWNER**  
HOME PROJECT 472, LLC  
3009 112TH AVE NE, SUITE 100, BELLEVUE, WA 98004  
ERIC SADLER  
425.429.6645  
PERMITS@MNCUSTOM.COM

**GENERAL CONTRACTOR**  
MN CUSTOM HOMES  
3009 112TH AVE NE, SUITE 100, BELLEVUE, WA 98004  
KARL LEWIS  
425.429.6645  
KARL@MNCUSTOM.COM

**SURVEYOR**  
TERRANE  
10601 MAIN STREET, SUITE 102, BELLEVUE, WA 98004  
DANNY SLAGER  
425.233.6088  
DANNYS@TERRANE.NET

**CIVIL ENGINEER**  
CE SOLUTIONS  
102 NW CANAL ST, SEATTLE, WA 98107  
DUFFY ELLIS  
206.930.0342  
DUFFY@CESOLUTIONS.US

**STRUCTURAL ENGINEER**  
MALSAM TSANG ENGINEERING  
122 S JACKSON ST, SUITE 210, SEATTLE, WA 98104  
WARREN CENT  
206.789.6038  
WARRENC@MALSAM-TSANG.COM

**GEOTECHNICAL ENGINEER**  
SOUTH FORK GEOSCIENCES  
P.O. BOX 1275, NORTH BEND, WA 98045  
ANDREW GLANDON  
425-890-4858  
ANDREW@SFGEO.COM

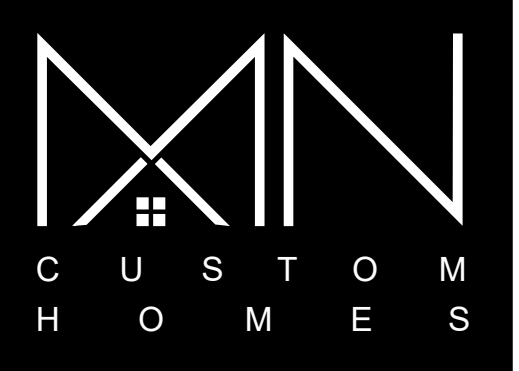

3009 112th Ave NE, Suite 100  
Bellevue, WA 98004  
T (425) 429-6645  
F (888) 224-0299  
mncustom.com  
copyright © 2022

CONSULTANT

STAMP

MN NO.

**MN472**

**7119 80TH AVE SE  
MERCER ISLAND, WA 98040**

**SITE PLAN**

**REVISION HISTORY**

Δ	DATE	SUBMISSION
1	12-05-2023	REV 1
2	02-01-2024	REV 2
3	03-18-2024	REV 3

DATE: 04-12-2024

SCALE: AS NOTED

SET TYPE: PERMIT

SHEET NUMBER

**A1.1**









3009 112th Ave NE, Suite 100  
Bellevue, WA 98004  
T (425) 429-6645  
F (888) 224-0299  
mcustom.com  
copyright © 2022

CONSULTANT

STAMP

MIN. NO.

**MN472**

**7119 80TH AVE SE  
MERCER ISLAND, WA 98040**

**MAIN LEVEL FLOOR PLAN**

REVISION HISTORY

Δ	DATE	SUBMISSION
2	02-01-2024	REV 2

DATE: 04-12-2024

SCALE: AS NOTED

SET TYPE: PERMIT

SHEET NUMBER

**A2.2**

- GLAZING NOTES**
- GLAZING SHALL BE IN ACCORDANCE WITH IRC SECTION R308.
  - LOCKING DEVICES SHALL BE PROVIDED ON ALL SLIDING DOORS AND OPENING WINDOWS AND COMPLY WITH R329.3
  - EXTERIOR GLAZING.** ALL EXTERIOR WALL GLAZING SHALL BE DOUBLE-GLAZED AND COMPLY WITH WAC 51-11 AS WELL AS DESIGNED TO WITHSTAND WIND PER R301.2.
  - SAFETY GLAZING.** PROVIDE IN AREAS SUBJECT TO HUMAN IMPACT PER SECTION R308.1 & R308.4. SUCH HAZARDOUS LOCATIONS INCLUDE:
    - GLAZING IN FIXED AND OPERABLE PANELS OF SWINGING, SLIDING, OR FOLDING DOOR ASSEMBLIES
    - GLAZING IN AN INDIVIDUAL FIXED OR OPERABLE PANEL ADJACENT TO A DOOR WHERE THE NEAREST VERTICAL EDGE IS WITHIN A 24-INCH ARC OF THE DOOR IN A CLOSED POSITION AND WHOSE BOTTOM EDGE IS LESS THAN 60 INCHES ABOVE THE FLOOR OR WALKING SURFACE UNLESS THERE IS A PERMANENT INTERVENING BARRIER. IT IS ADJACENT TO THE FIXED PANEL OF A PATIO DOOR, OR DECORATIVE GLAZING.
    - GLAZING IN STORM DOORS.
    - GLAZING IN DOORS AND ENCLOSURES FOR BATHTUBS AND SHOWERS.
    - GLAZING IN AN PART OF A BUILDING WALL ENCLOSING THESE COMPARTMENTS WHERE THE BOTTOM EXPOSED EDGE OF THE GLAZING IS 60 INCHES MEASURED VERTICALLY ABOVE ANY STANDING OR WALKING SURFACE.
    - GLAZING WITHIN 60" OF THE BOTTOM TREAD OF A STAIRWAY IN ANY DIRECTION
    - GLAZING LESS THAN 36" ABOVE PLANE OF ADJACENT STAIRWAYS, LANDINGS, RAMPS WITHIN 36" OF A WALKING SURFACE
  - GLAZING IN AN INDIVIDUAL OR FIXED PANEL THAT MEETS ANY OF THE FOLLOWING CONDITIONS:**
    - EXPOSED AREA OF AN INDIVIDUAL PANE GREATER THAN 9 SQUARE FEET.
    - BOTTOM EDGE LESS THAN 18 INCHES ABOVE THE FLOOR.
    - TOP EDGE GREATER THAN 36 INCHES ABOVE THE FLOOR.
    - ONE OR MORE WALKING SURFACES WITHIN 36 INCHES HORIZONTALLY OF THE GLAZING.
    - ALL GLAZING IN RAILINGS, REGARDLESS OF AN AREA OR HEIGHT ABOVE WALKING SURFACE. INCLUDED ARE STRUCTURAL BALUSTER PANELS AND NONSTRUCTURAL I FILL PANELS.
    - GLAZING IN WALLS AND FENCES ENCLOSING INDOOR AND OUTDOOR SWIMMING POOLS, HOT TUBS, AND SPAS WHERE THE BOTTOM EDGE OF THE GLAZING IS LESS THAN 60 INCHES ABOVE A WALKING SURFACE AND WITHIN 60 INCHES HORIZONTAL OF THE WATER'S EDGE.
    - GLAZING ADJACENT TO STAIRWAYS, LANDINGS, AND RAMPS WITHIN 36 INCHES HORIZONTALLY OF A WALKING SURFACE WHEN THE EXPOSED SURFACE OF THE GLASS IS LESS THAN 60 INCHES ABOVE THE PLANE OF THE ADJACENT WALKING SURFACE
    - GLAZING ADJACENT TO STAIRWAYS WITHIN 60 INCHES HORIZONTALLY OF THE BOTTOM TREAD OF A STAIRWAY IN ANY DIRECTION WHEN THE EXPOSED SURFACE OF THE GLASS IS LESS THAN 60 INCHES ABOVE THE NOSE OF THE TREAD.

**EXHAUST RATES**  
WSEC AMENDMENTS TO IRC M1505. ALL FANS VENT TO OUTSIDE. MEET ALL REQUIREMENTS OF M1505 AND AMENDMENTS.

**BATHROOMS, POWDER**  
MINIMUM 50 CFM AT .25" WG

**KITCHEN**  
MINIMUM 100CFM INTERMITTENT, 30CFM CONT. RANGE HOOD OR DOWN DRAFT EXHAUST FAN RATED AT 100 CFM AT 1" W.G. MAY BE USED FOR EXHAUST FAN REQUIREMENT. FANS IN EXCESS OF 400CFM SHALL PROVIDE MAKE UP AIR.

**LAUNDRY ROOM - WHOLE HOUSE MECHANICAL VENTILATION**  
WHOLE HOUSE FAN MUST OPERATE 3 HRS IN ANY 4 HR PERIOD AND 16 HRS IN ANY 24 HR PERIOD  
WHOLE HOUSE VENTILATION USING EXHAUST FANS  
M1505.4.3 AIRFLOW RATE: 124 cfm

**EGRESS AND STAIRS**

**STAIRS**  
PROVIDE 1/2 INCH GYP AT ENCLOSED AND ACCESSIBLE UNDERSTAIR SPACES - ALL SIDES. ALL STAIRS, HANDRAILS, AND GUARDRAILS SHALL CONFORM TO IRC SECTION 311 AND 312  
PROVIDE 1/2 INCH GYP AT ENCLOSED AND ACCESSIBLE UNDERSTAIR SPACES - ALL SIDES. ALL STAIRS, HANDRAILS, AND GUARDRAILS SHALL CONFORM TO IRC SECTION 311 AND 312  
STAIRWAYS SHALL HAVE A CLEAR HEIGHT OF 80" ABOVE NOSING  
STAIRS SHALL COMPLY WITH R311.7; NOT LESS THAN 36" IN WIDTH, STAIRS SHALL HAVE A MINIMUM TREAD DEPTH OF 10" AND A MAXIMUM RISER HEIGHT OF 7 3/4"

**EGRESS OPENINGS**  
EMERGENCY ESCAPE AND RESCUE OPENINGS SHALL HAVE A MINIM NET CLEAR OPENING OF 5.7 SQ. FT. EXCEPT GRADE FLOOR OPENINGS SHALL BE 5 SQ. FT. MINIMUM. THE MINIMUM NET CLEAR OPENING HEIGHT DIMENSION SHALL BE 24" AND THE MINIMUM NET CLEAR OPENING WIDTH DIMENSION SHALL BE 20" PER IRC SECTION R310. T SILL OF THE OPENING SHALL BE NOT MORE THAN 44 INCHES ABOVE THE FLOOR. PROVIDE ONE EGRESS WINDOW PER BEDROOM

**HANDRAILS**  
PROVIDE AT LEAST ONE HANDRAIL AT EVERY STAIRWAY HAVING FOUR OR MORE RISERS. PROVIDE 2 HANDRAILS WHERE SHOWN ON PLANS. HANDRAILS SHALL BE CONTINUOUS THE FULL LENGTH OF THE FLIGHT FROM A POINT DIRECTLY ABOVE THE TOP RISER OF A FLIGHT A POINT DIRECTLY ABOVE THE LOWEST RISER OF THE FLIGHT AND SHALL BE RETURNED OR TERMINATE IN NEWEL POSTS. HANDRAILS ARE PERMITTED TO BE INTERRUPTED BY NEWEL POSTS AT THE TURN, AND MAY START OVER THE LOWEST TREAD.

HANDRAIL HEIGHT, MEASURED ABOVE STAIR TREAD NOSINGS, OR FINISH SURFACE OF RAM SLOPE, SHALL BE UNIFORM, NOT LESS THAN 34" AND NOT MORE THAN 38". HANDRAILS WITH CIRCULAR CROSS SECTION SHALL HAVE AN OUTSIDE DIAMETER OF AT LEAST 1.25" AND NOT GREATER THAN 2" OR SHALL PROVIDE EQUIVALENT GRASPABILITY. IF THE HANDRAIL IS NOT CIRCULAR, IT SHALL HAVE A PERIMETER DIMENSION OF AT LEAST 4" AND NOT GREATER THAN 6.25" WITH A MAXIMUM CROSS-SECTION DIMENSION OF 2.25".

**GUARDS**  
GUARDS SHALL BE LOCATED ALONG OPEN-SIDED WALKING SURFACES, MEZZANINES, INDUSTRIAL EQUIPMENT PLATFORMS, STAIRWAYS, RAMPS AND LANDINGS WHICH ARE LOCATED MORE THAN 30" ABOVE THE FLOOR OR GRADE BELOW. GUARDS SHALL BE ADEQUATE IN STRENGTH AND ATTACHMENT IN ACCORDANCE WITH SECTION 1607.7. (IBC SEC. 1012.1) GUARDS WHOSE TOP RAIL ALSO SERVES AS A HANDRAIL SHALL HAVE A HEIGHT NOT LESS THAN 34" AND NOT MORE THAN 38" MEASURED VERTICALLY FROM THE LEADING EDGE OF THE STAIR TREAD NOSING. (IBC SEC. 1012.2)

OPEN GUARDS SHALL HAVE BALUSTERS OR ORNAMENTAL PATTERNS SUCH THAT A 4"-DIAMETER SPHERE CANNOT PASS THROUGH ANY OPENING UP TO A HEIGHT OF 34". FROM HEIGHT OF 34" TO 42" ABOVE THE ADJACENT WALKING SURFACES, A SPHERE 8" IN DIAMETER SHALL NOT PASS. EXCEPTIONS: THE TRIANGULAR OPENINGS FORMED BY THE RISER, TREAD AND BOTTOM RAIL AT THE OPEN SIDE OF A STAIRWAY SHALL BE OF A MAXIMUM SIZE SUCH THAT A SPHERE OF 6" IN DIAMETER CANNOT PASS THROUGH THE OPENING PER IRC SECTION R312

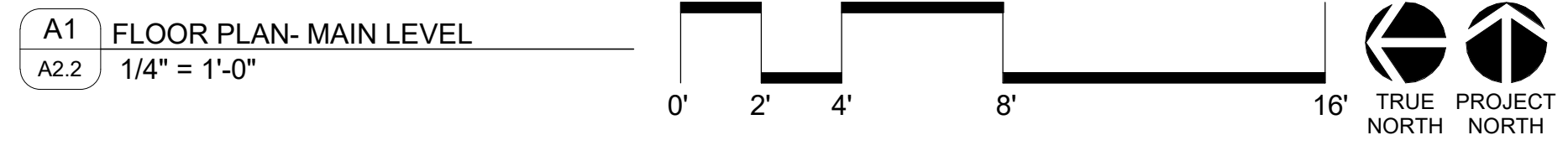
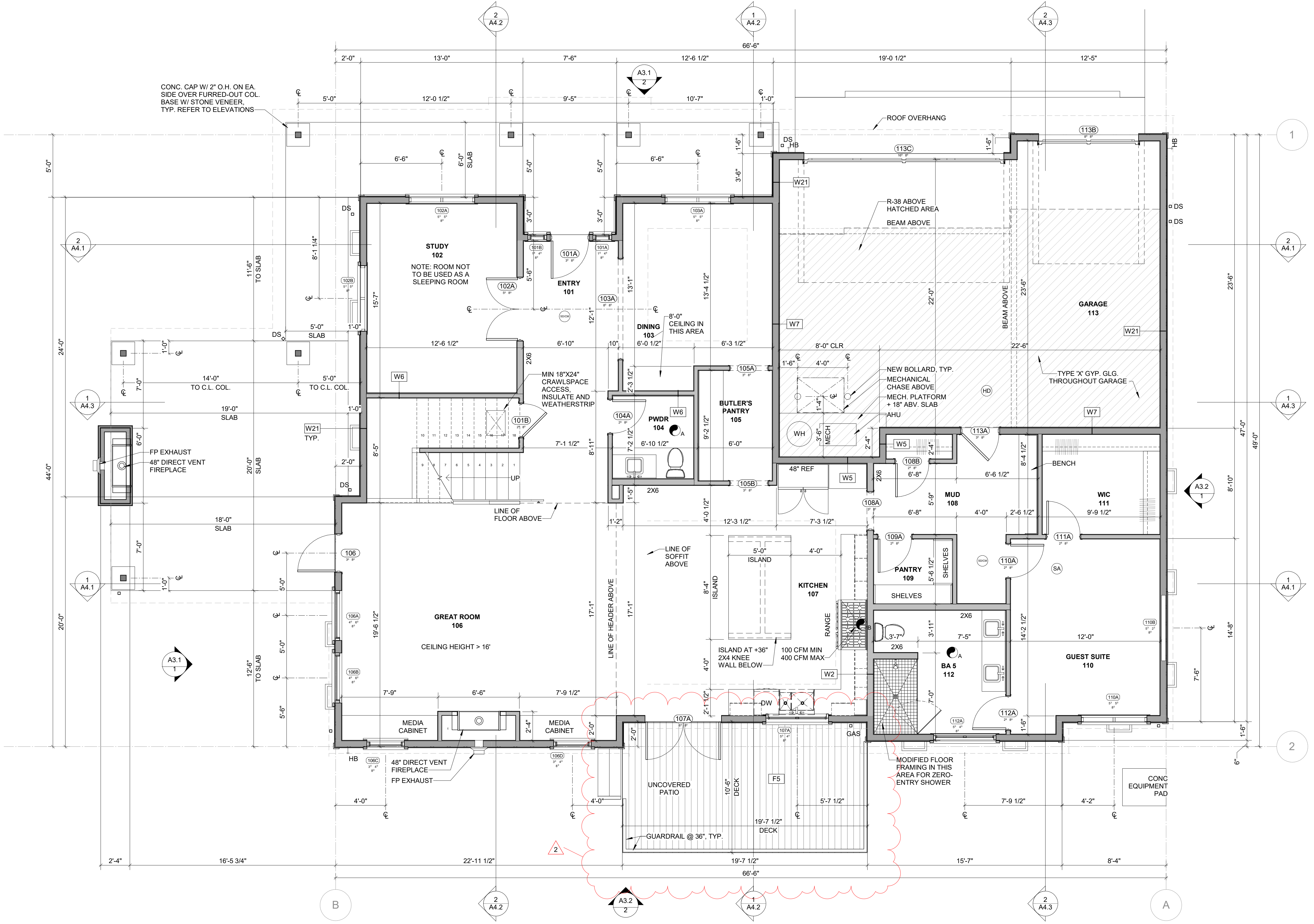

- FLOOR PLAN NOTES**
- ALL DIMENSIONS ARE TO FACE OF CONCRETE, FACE OF FRAMING, UNLESS NOTED OTHERWISE.
  - ALL EXTERIOR WALLS ARE 2X6 AT 16" O.C. WITH R-21 INSULATION UNLESS NOTED OTHERWISE
  - ALL INTERIOR PARTITIONS ARE 2X4 UNLESS NOTED OTHERWISE
  - SMOKE DETECTORS SHALL BE INSTALLED AND LOCATED PER IRC R315. CARBON MONOXIDE DETECTORS SHALL BE INSTALLED AND LOCATED PER IRC R315.
  - DOORS NOT DIMENSIONED SHALL BE CENTERED OR LOCATED 4" AWAY FROM ADJACENT WALL AT HINGE SIDE
  - WINDOWS NOT DIMENSIONED SHALL BE LOCATED TIGHT TO WALL CORNERS
  - WHERE WALLS ARE NOT DIMENSIONED AT CORNERS, ALIGN FRAMING FOR CONT FACE OF GYP
  - VENT ALL EXHAUST FANS AND HOODS TO THE EXTERIOR THROUGH THE ROOF
  - ALL HANDRAILS TO BE +36" AFF
  - ALL GUARDRAILS TO BE +36" AFF
  - PROVIDE ACOUSTICAL INSULATION AT ALL INTERIOR BATHROOM, POWDER ROOM, AND BEDROOMS WALLS AND FLOORS
  - ANY GRID LINES SHOWN ARE LOCATED TO FACE OF CONCRETE AND FRAMING, UNO
  - AT LOWER LEVEL, FACE OF FRAMING ALIGNS TO FACE OF FOUNDATION. NOTIFY DESIGNER OF DISCREPANCIES.
  - ONE WINDOW PER BEDROOM SHALL MEET EGRESS CODE REQUIREMENTS PER IRC R310.1
  - AT BATHTUBS AND SHOWERS, VERIFY THE RO NEEDED AND COORDINATE FRAMING LOCATIONS TO EQUIP
  - WHERE DOWNSPOUTS FROM AN UPPER ROOF TRANSITION TO A LOWER ROOF PROVIDE SPLASH BLOCKS

**NOTE:** A NFPA 13D FIRE SPRINKLER SYSTEM IN COMPLIANCE WITH NFPA 13D AND COMI STANDARDS SHALL BE INSTALLED THROUGHOUT THE RESIDENCE. A SEPARATE FIRE PERMIT IS REQUIRED.

- ALARM SCHEDULE**  
2018 IRC 314 AND 315
- SMOKE ALARM**  
110v INTERCONNECTED WITH BATTERY BACKUP. INSTALLED IN EACH FLOOR, IN EACH SLEEPING AREA, AND OUTSIDE EACH SEPARATE SLEEPING AREA. INSTALLED NOT LESS THAN 3 FEET FROM THE DOOR OF A BATH WHICH CONTAINS A TUB OR SHOWER UNLESS THIS PREVENTS PLACEMENT IN A REQUIRED LOCATION. EQUIPMENT TO BE LISTED WITH UL 217 AND TO COMPLY WITH NFPA 72
- COMBINATION SMOKE ALARM AND CARBON MONOXIDE ALARM**  
INSTALLED ON EACH FLOOR AND OUTSIDE OF EACH SEPARATE SLEEPING AREA IN THE IMMEDIATE VICINITY OF THE BEDROOMS, AND IN A BEDROOM THAT CONTAINS GAS FIREPLACE ION THE BEDROOM OR ADJACENT BATHROOM. MEET SMOKE ALARM REQUIREMENTS ABOVE. EQUIPMENT TO BE LISTED WITH UL 217 AND UL 2034
- HEAT DETECTOR**  
A HEAT DETECTOR OR HEAT ALARM TO BE INSTALLED IN A CENTRAL LOCATION IN THE GARAGE AND PER MANUF INSTRUCTIONS. LISTED AND TESTED FOR USE. HEAT DETECTORS AND ALARMS SHALL BE CONNECTED TO AN ALARM OR SMOKE ALARM INSTALLED IN THE DWELLING



Δ	DATE	SUBMISSION
1	12-05-2023	REV 1

DATE: 04-12-2024

SCALE: AS NOTED

SET TYPE: PERMIT

**GLAZING NOTES**

- GLAZING SHALL BE IN ACCORDANCE WITH IRC SECTION R308.
- LOCKING DEVICES SHALL BE PROVIDED ON ALL SLIDING DOORS AND OPENING WINDOWS AND COMPLY WITH R329.3
- EXTERIOR GLAZING.** ALL EXTERIOR WALL GLAZING SHALL BE DOUBLE-GLAZED AND COMPLY WITH WAC 51-11 AS WELL AS DESIGNED TO WITHSTAND WIND PER R301.2.1.
- SAFETY GLAZING.** PROVIDE IN AREAS SUBJECT TO HUMAN IMPACT PER SECTION R308.1 & R308.4. SUCH HAZARDOUS LOCATIONS INCLUDE:
  - GLAZING IN FIXED AND OPERABLE PANELS OF SWINGING, SLIDING, OR FOLDING DOOR ASSEMBLIES
  - GLAZING IN AN INDIVIDUAL FIXED OR OPERABLE PANEL ADJACENT TO A DOOR WHERE THE NEAREST VERTICAL EDGE IS WITHIN A 24-INCH ARC OF THE DOOR IN A CLOSED POSITION AND WHOSE BOTTOM EDGE IS LESS THAN 60 INCHES ABOVE THE FLOOR OR WALKING SURFACE UNLESS THERE IS A PERMANENT INTERVENING BARRIER, IT IS ADJACENT TO THE FIXED PANEL OF A PATIO DOOR, OR DECORATIVE GLAZING.
  - GLAZING IN STORM DOORS.
  - GLAZING IN DOORS AND ENCLOSURES FOR BATHTUBS AND SHOWERS.
  - GLAZING IN A PART OF A BUILDING WALL ENCLOSING THESE COMPARTMENTS WHERE THE BOTTOM EXPOSED EDGE OF THE GLAZING IS 60 INCHES MEASURED VERTICALLY ABOVE ANY STANDING OR WALKING SURFACE.
  - GLAZING WITHIN 60" OF THE BOTTOM TREAD OF A STAIRWAY IN ANY DIRECTION
  - GLAZING LESS THAN 36" ABOVE PLANE OF ADJACENT STAIRWAYS, LANDINGS, RAMPS WITHIN 36" OF A WALKING SURFACE
- GLAZING IN AN INDIVIDUAL OR FIXED PANEL THAT MEETS ANY OF THE FOLLOWING CONDITIONS:**
  - EXPOSED AREA OF AN INDIVIDUAL PANE GREATER THAN 9 SQUARE FEET.
  - BOTTOM EDGE LESS THAN 18 INCHES ABOVE THE FLOOR.
  - TOP EDGE GREATER THAN 36 INCHES ABOVE THE FLOOR.
  - ONE OR MORE WALKING SURFACES WITHIN 36 INCHES HORIZONTALLY OF THE GLAZING.
  - ALL GLAZING IN RAILINGS, REGARDLESS OF AN AREA OR HEIGHT ABOVE WALKING SURFACE. INCLUDED ARE STRUCTURAL BALUSTER PANELS AND NONSTRUCTURAL I-FILL PANELS.
  - GLAZING IN WALLS AND FENCES ENCLOSING INDOOR AND OUTDOOR SWIMMING POOLS, HOT TUBS, AND SPAS WHERE THE BOTTOM EDGE OF THE GLAZING IS LESS THAN 60 INCHES ABOVE A WALKING SURFACE AND WITHIN 60 INCHES HORIZONTAL OF THE WATER'S EDGE.
  - GLAZING ADJACENT TO STAIRWAYS, LANDINGS, AND RAMPS WITHIN 36 INCHES HORIZONTALLY OF A WALKING SURFACE WHEN THE EXPOSED SURFACE OF THE GLASS IS LESS THAN 60 INCHES ABOVE THE PLANE OF THE ADJACENT WALKING SURFACE
  - GLAZING ADJACENT TO STAIRWAYS WITHIN 60 INCHES HORIZONTALLY OF THE BOTTOM TREAD OF A STAIRWAY IN ANY DIRECTION WHEN THE EXPOSED SURFACE OF THE GLASS IS LESS THAN 60 INCHES ABOVE THE NOSE OF THE TREAD.

**EGRESS AND STAIRS**

**STAIRS**

- PROVIDE 1/2 INCH GYP AT ENCLOSED AND ACCESSIBLE UNDERSTAIR SPACES - ALL SIDES. ALL STAIRS, HANDRAILS, AND GUARDRAILS SHALL CONFORM TO IRC SECTION 311 AND 312
- PROVIDE 1/2 INCH GYP AT ENCLOSED AND ACCESSIBLE UNDERSTAIR SPACES - ALL SIDES. ALL STAIRS, HANDRAILS, AND GUARDRAILS SHALL CONFORM TO IRC SECTION 311 AND 312
- STAIRWAYS SHALL HAVE A CLEAR HEIGHT OF 80" ABOVE NOSING
- STAIRS SHALL COMPLY WITH R311.7; NOT LESS THAN 36" IN WIDTH.
- STAIRS SHALL HAVE A MINIMUM TREAD DEPTH OF 10" AND A MAXIMUM RISER HEIGHT OF 7 3/4"

**EGRESS OPENINGS**

EMERGENCY ESCAPE AND RESCUE OPENINGS SHALL HAVE A MINIM NET CLEAR OPENING OF 5.7 SQ. FT. EXCEPT GRADE FLOOR OPENINGS SHALL BE 5 SQ. FT. MINIMUM. THE MINIMUM NET CLEAR OPENING HEIGHT DIMENSION SHALL BE 24" AND THE MINIMUM NET CLEAR OPENING WIDTH DIMENSION SHALL BE 20" PER IRC SECTION R310.1. SILL OF THE OPENING SHALL BE NOT MORE THAN 44 INCHES ABOVE THE FLOOR. PROVIDE ONE EGRESS WINDOW PER BEDROOM.

**HANDRAILS**

PROVIDE AT LEAST ONE HANDRAIL AT EVERY STAIRWAY HAVING FOUR OR MORE RISERS. PROVIDE 2 HANDRAILS WHERE SHOWN ON PLANS. HANDRAILS SHALL BE CONTINUOUS THE FULL LENGTH OF THE FLIGHT FROM A POINT DIRECTLY ABOVE THE TOP RISER OF A FLIGHT A POINT DIRECTLY ABOVE THE LOWEST RISER OF THE FLIGHT AND SHALL BE RETURNED OR TERMINATE IN NEWEL POSTS. HANDRAILS ARE PERMITTED TO BE INTERRUPTED BY NEWEL POSTS AT THE TURN, AND MAY START OVER THE LOWEST TREAD.

HANDRAIL HEIGHT, MEASURED ABOVE STAIR TREAD NOSINGS, OR FINISH SURFACE OF RAM SLOPE, SHALL BE UNIFORM, NOT LESS THAN 34" AND NOT MORE THAN 38". HANDRAILS WITH CIRCULAR CROSS SECTION SHALL HAVE AN OUTSIDE DIAMETER OF AT LEAST 1.25" AND NOT GREATER THAN 2" OR SHALL PROVIDE EQUIVALENT GRASPABILITY. IF THE HANDRAIL IS NOT CIRCULAR, IT SHALL HAVE A PERIMETER DIMENSION OF AT LEAST 4" AND NOT GREATER THAN 6.25" WITH A MAXIMUM CROSS-SECTION DIMENSION OF 2.25".

**GUARDS**

GUARDS SHALL BE LOCATED ALONG OPEN-SIDED WALKING SURFACES, MEZZANINES, INDUSTRIAL EQUIPMENT PLATFORMS, STAIRWAYS, RAMPS AND LANDINGS WHICH ARE LOCATED MORE THAN 30" ABOVE THE FLOOR OR GRADE BELOW. GUARDS SHALL BE ADEQUATE IN STRENGTH AND ATTACHMENT IN ACCORDANCE WITH SECTION 1607.7. (IBC SEC. 1012.1) GUARDS WHOSE TOP RAIL ALSO SERVES AS A HANDRAIL SHALL HAVE A HEIGHT NOT LESS THAN 34" AND NOT MORE THAN 38" MEASURED VERTICALLY FROM THE LEADING EDGE OF THE STAIR TREAD NOSING. (IBC SEC. 1012.2)

OPEN GUARDS SHALL HAVE BALUSTERS OR ORNAMENTAL PATTERNS SUCH THAT A 4"-DIAMETER SPHERE CANNOT PASS THROUGH ANY OPENING UP TO A HEIGHT OF 34". FROM HEIGHT OF 34" TO 42" ABOVE THE ADJACENT WALKING SURFACES, A SPHERE 8" IN DIAMETER SHALL NOT PASS. EXCEPTIONS: THE TRIANGULAR OPENINGS FORMED BY THE RISER, TREAD AND BOTTOM RAIL AT THE OPEN SIDE OF A STAIRWAY SHALL BE OF A MAXIMUM SIZE SUCH THAT A SPHERE OF 6" IN DIAMETER CANNOT PASS THROUGH THE OPENING PER IRC SECTION R312

**EXHAUST RATES**

WSEC AMENDMENTS TO IRC M1505. ALL FANS VENT TO OUTSIDE. MEET ALL REQUIREMENTS OF M1505 AND AMENDMENTS.

- BATHROOMS, POWDER**  
MINIMUM 50 CFM AT 25" WG
- KITCHEN**  
MINIMUM 100CFM INTERMITTENT, 30CFM CONT. RANGE HOOD OR DOWN DRAFT EXHAUST FAN RATED AT 100 CFM AT .10" WG MAY BE USED FOR EXHAUST FAN REQUIREMENT. FANS IN EXCESS OF 400CFM SHALL PROVIDE MAKE UP AIR.
- LAUNDRY ROOM - WHOLE HOUSE MECHANICAL VENTILATION**  
WHOLE HOUSE FAN MUST OPERATE 3 HRS IN ANY 4 HR PERIOD AND 18 HRS IN ANY 24 HR PERIOD.  
WHOLE HOUSE VENTILATION USING EXHAUST FANS  
M1505.4.3 AIRFLOW RATE: 124 cfm

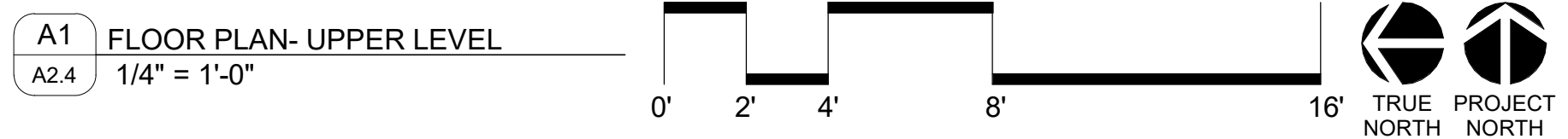
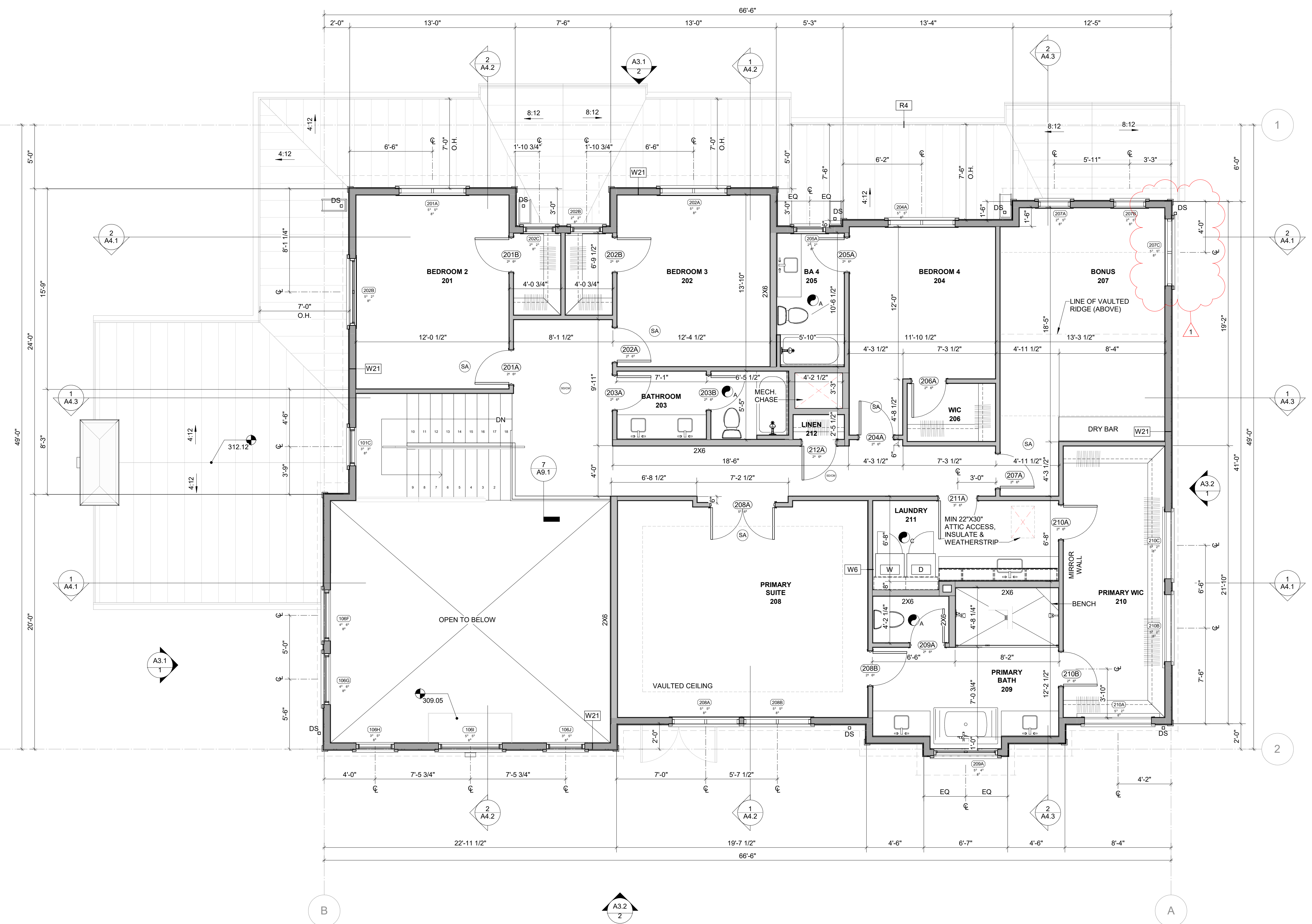

- FLOOR PLAN NOTES**
- ALL DIMENSIONS ARE TO FACE OF CONCRETE, FACE OF FRAMING, UNLESS NOTED OTHERWISE.
  - ALL EXTERIOR WALLS ARE 2X6 AT 16" O.C. WITH R-21 INSULATION UNLESS NOTED OTHERWISE.
  - ALL INTERIOR PARTITIONS ARE 2X4 UNLESS NOTED OTHERWISE.
  - SMOKE DETECTORS SHALL BE INSTALLED AND LOCATED PER IRC R315. CARBON MONOXIDE DETECTORS SHALL BE INSTALLED AND LOCATED PER IRC R315.
  - DOORS NOT DIMENSIONED SHALL BE CENTERED OR LOCATED 4" AWAY FROM ADJACENT WALL AT HINGE SIDE.
  - WINDOWS NOT DIMENSIONED SHALL BE LOCATED TIGHT TO WALL CORNERS.
  - WHERE WALLS ARE NOT DIMENSIONED AT CORNERS, ALIGN FRAMING FOR CONT FACE OF GYP.
  - VENT ALL EXHAUST FANS AND HOODS TO THE EXTERIOR THROUGH THE ROOF.
  - ALL HANDRAILS TO BE +36" AFF.
  - ALL GUARDRAILS TO BE +36" AFF.
  - PROVIDE ACOUSTICAL INSULATION AT ALL INTERIOR BATHROOM, POWDER ROOM, AND BEDROOMS WALLS AND FLOORS.
  - ANY GRID LINES SHOWN ARE LOCATED TO FACE OF CONCRETE AND FRAMING, UNO.
  - AT LOWER LEVEL, FACE OF FRAMING ALIGNS TO FACE OF FOUNDATION. NOTIFY DESIGNER OF DISCREPANCIES.
  - ONE WINDOW PER BEDROOM SHALL MEET EGRESS CODE REQUIREMENTS PER IRC R310.1.
  - AT BATHROOMS AND SHOWERS, VERIFY THE RO NEEDED AND COORDINATE FRAMING LOCATIONS TO EQUIP.
  - WHERE DOWNSPOUTS FROM AN UPPER ROOF TRANSITION TO A LOWER ROOF PROVIDE SPLASH BLOCKS.

**NOTE:** A NFPA 13D FIRE SPRINKLER SYSTEM IN COMPLIANCE WITH NFPA 13D AND COMI STANDARDS SHALL BE INSTALLED THROUGHOUT THE RESIDENCE. A SEPARATE FIRE PERMIT IS REQUIRED.

- ALARM SCHEDULE**  
2018 IRC 314 AND 315
- SMOKE ALARM**  
110v INTERCONNECTED WITH BATTERY BACKUP. INSTALLED IN EACH FLOOR, IN EACH SLEEPING AREA, AND OUTSIDE EACH SEPARATE SLEEPING AREA. INSTALLED NOT LESS THAN 3 FEET FROM THE DOOR OF A BATH WHICH CONTAINS A TUB OR SHOWER UNLESS THIS PREVENTS PLACEMENT IN A REQUIRED LOCATION. EQUIPMENT TO BE LISTED WITH UL 217 AND TO COMPLY WITH NFPA 72
  - COMBINATION SMOKE ALARM AND CARBON MONOXIDE ALARM**  
INSTALLED ON EACH FLOOR AND OUTSIDE OF EACH SEPARATE SLEEPING AREA IN THE IMMEDIATE VICINITY OF THE BEDROOMS, AND IN A BEDROOM THAT CONTAINS GAS FIREPLACE ION THE BEDROOM OR ADJACENT BATHROOM. MEET SMOKE ALARM REQUIREMENTS ABOVE. EQUIPMENT TO BE LISTED WITH UL 217 AND UL 2034
  - HEAT DETECTOR**  
A HEAT DETECTOR OR HEAT ALARM TO BE INSTALLED IN A CENTRAL LOCATION IN THE GARAGE AND PER MANUF INSTRUCTIONS. EQUIPMENT TO BE LISTED AND TESTED FOR USE. HEAT DETECTORS AND ALARMS SHALL BE CONNECTED TO AN ALARM OR SMOKE ALARM INSTALLED IN THE DWELLING









3009 112th Ave NE, Suite 100  
 Bellevue, WA 98004  
 T (425) 429-6645  
 F (888) 224-0299  
 mcustom.com  
 copyright © 2022

**ELEVATION NOTES**

1. VERIFY SHEAR WALL NAILING AND HOLD DOWNS PER STRUCT
2. PRIOR TO INSTALLING SIDING
3. CAULK ALL EXTERIOR JOINTS AND PENETRATIONS
4. PROVIDE CORROSION RESISTANT FLASHING AT EXTERIOR WALL ENVELOPE PER IRC R703.8
5. PROVIDE FLASHINGS AT ROOF PENETRATIONS PER IRC R903.2
6. PROVIDE WEATHER STRIPPING AT ALL EXTERIOR AND GARAGE DOORS
7. PROVIDE CONTINUOUS GUTTERS AND DOWNSPOUTS AT ALL EAVES
8. ROOF EAVES WITHIN 5'-0" OF PROPERTY LINE TO HAVE FIRE BLOCKING FROM THE WALL TOP PLATE TO UNDER SIDE OF ROOF SHEATHING, IRC R302.1
9. HOUSE NUMBER TO BE VISIBLE FROM THE STREET. MIN 6" HIGH
10. PROVIDE EXTERIOR STAIRWAY ILLUMINATION PER IRC R308.8
11. SLOPE GRADE AWAY FROM RESIDENCE PER IRC 401.3
12. REFER TO A0.1 FOR ADDITIONAL NOTES

EXTERIOR ELEVATION MATERIALS	
TAG	DESCRIPTION
BB1	1X3 BATTENS @ 24" OC COLOR 1
DS1	PAINTED DOWNSPOUT TO MATCH SIDING COLOR
LP1	6" LAP SIDING COLOR 1
PL1	PANEL SIDING COLOR 1
RF1	COMPOSITION SHINGLE ROOF
RF2	STANDING SEAM METAL ROOF
ST1	STONE VENEER SIDING
WD1	2X8 WOOD TRIM TYP. COLOR 1
WD2	2X10 WOOD TRIM TYP. COLOR 1
WD3	2X12 WOOD TRIM TYP. COLOR 1



2 EXTERIOR ELEVATION - FRONT  
 A3.1 1/4" = 1'-0"



1 EXTERIOR ELEVATION - RIGHT  
 A3.1 1/4" = 1'-0"

CONSULTANT

STAMP

MN NO.

**MN472**

**7119 80TH AVE SE  
 MERCER ISLAND, WA 98040**

**ELEVATIONS**

**REVISION HISTORY**

Δ	DATE	SUBMISSION
1	12-05-2023	REV 1

DATE: 04-12-2024

SCALE: AS NOTED

SET TYPE: PERMIT

SHEET NUMBER

**A3.1**





3009 112th Ave NE, Suite 100  
 Bellevue, WA 98004  
 T (425) 429-6645  
 F (888) 224-0299  
 mcustom.com  
 copyright © 2022

- ELEVATION NOTES**
1. VERIFY SHEAR WALL NAILING AND HOLD DOWNS PER STRUCT PRIOR TO INSTALLING SIDING
  2. CAULK ALL EXTERIOR JOINTS AND PENETRATIONS
  3. PROVIDE CORROSION RESISTANT FLASHING AT EXTERIOR WALL ENVELOPE PER IRC R703.8
  4. PROVIDE FLASHINGS AT ROOF PENETRATIONS PER IRC R903.2
  5. PROVIDE WEATHER STRIPPING AT ALL EXTERIOR AND GARAGE DOORS
  6. PROVIDE CONTINUOUS GUTTERS AND DOWNSPOUTS AT ALL EAVES
  7. ROOF EAVES WITHIN 5'-0" OF PROPERTY LINE TO HAVE FIRE BLOCKING FROM THE WALL TOP PLATE TO UNDER SIDE OF ROOF SHEATHING, IRC R302.1
  8. HOUSE NUMBER TO BE VISIBLE FROM THE STREET. MIN 6" HIGH
  9. PROVIDE EXTERIOR STAIRWAY ILLUMINATION PER IRC R308.8
  10. SLOPE GRADE AWAY FROM RESIDENCE PER IRC 401.3
  11. REFER TO A0.1 FOR ADDITIONAL NOTES

EXTERIOR ELEVATION MATERIALS	
TAG	DESCRIPTION
BB1	1X3 BATTENS @ 24" OC COLOR 1
DS1	PAINTED DOWNSPOUT TO MATCH SIDING COLOR
LP1	6" LAP SIDING COLOR 1
PL1	PANEL SIDING COLOR 1
RF1	COMPOSITION SHINGLE ROOF
RF2	STANDING SEAM METAL ROOF
ST1	STONE VENEER SIDING
WD1	2X8 WOOD TRIM TYP. COLOR 1
WD2	2X10 WOOD TRIM TYP. COLOR 1
WD3	2X12 WOOD TRIM TYP. COLOR 1









**SECTION NOTES**

1. VERIFY SHEAR WALL NAILING AND HOLD DOWNS PER STRUCT PRIOR TO INSTALLING SIDING
2. REFER TO ASSEMBLIES ON A0.1



3009 112th Ave NE, Suite 100  
 Bellevue, WA 98004  
 T (425) 429-6645  
 F (888) 224-0299  
 mncustom.com  
 copyright © 2022

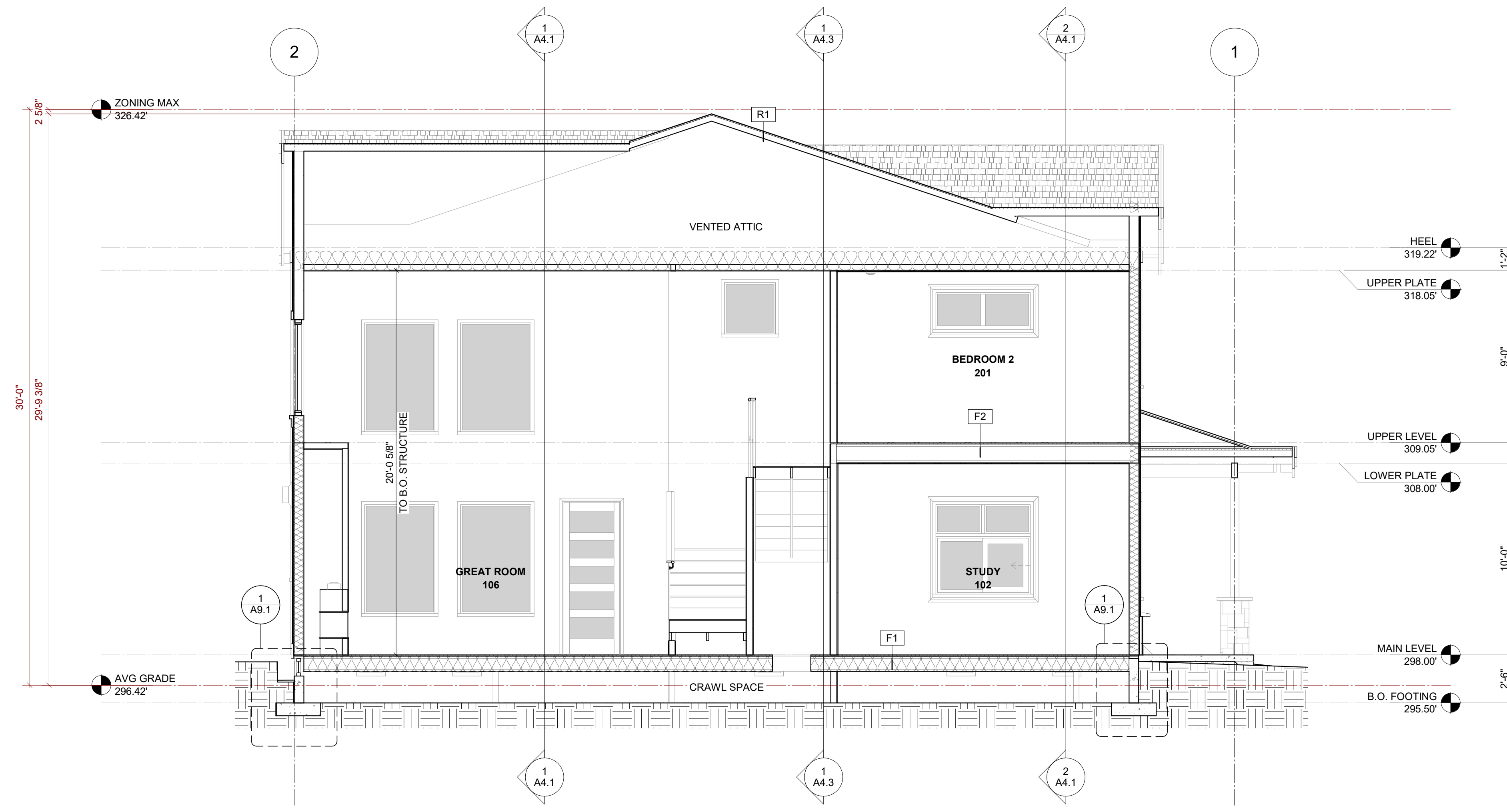

**2** OVERALL BUILDING SECTION III  
 A4.2 1/4" = 1'-0"

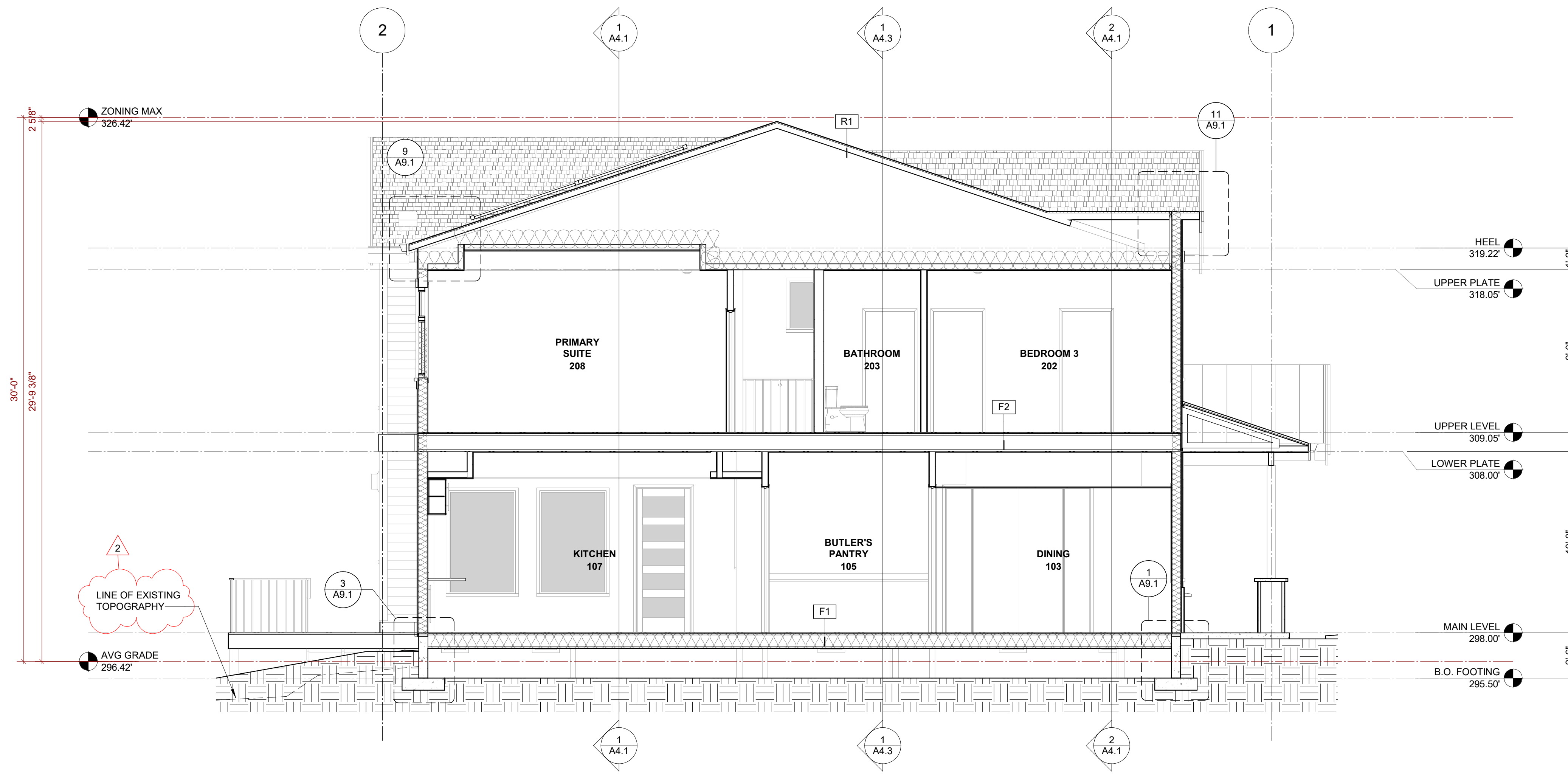

**1** OVERALL BUILDING SECTION IV  
 A4.2 1/4" = 1'-0"

CONSULTANT

STAMP

MN NO. **MN472**

**7119 80TH AVE SE  
 MERCER ISLAND, WA 98040**

**BUILDING SECTIONS**

**REVISION HISTORY**

DATE	SUBMISSION
02-01-2024	REV 2

DATE: 04-12-2024

SCALE: AS NOTED

SET TYPE: PERMIT

SHEET NUMBER **A4.2**



**SECTION NOTES**

1. VERIFY SHEAR WALL NAILING AND HOLD DOWNS PER STRUCT PRIOR TO INSTALLING SIDING
2. REFER TO ASSEMBLIES ON A0.1

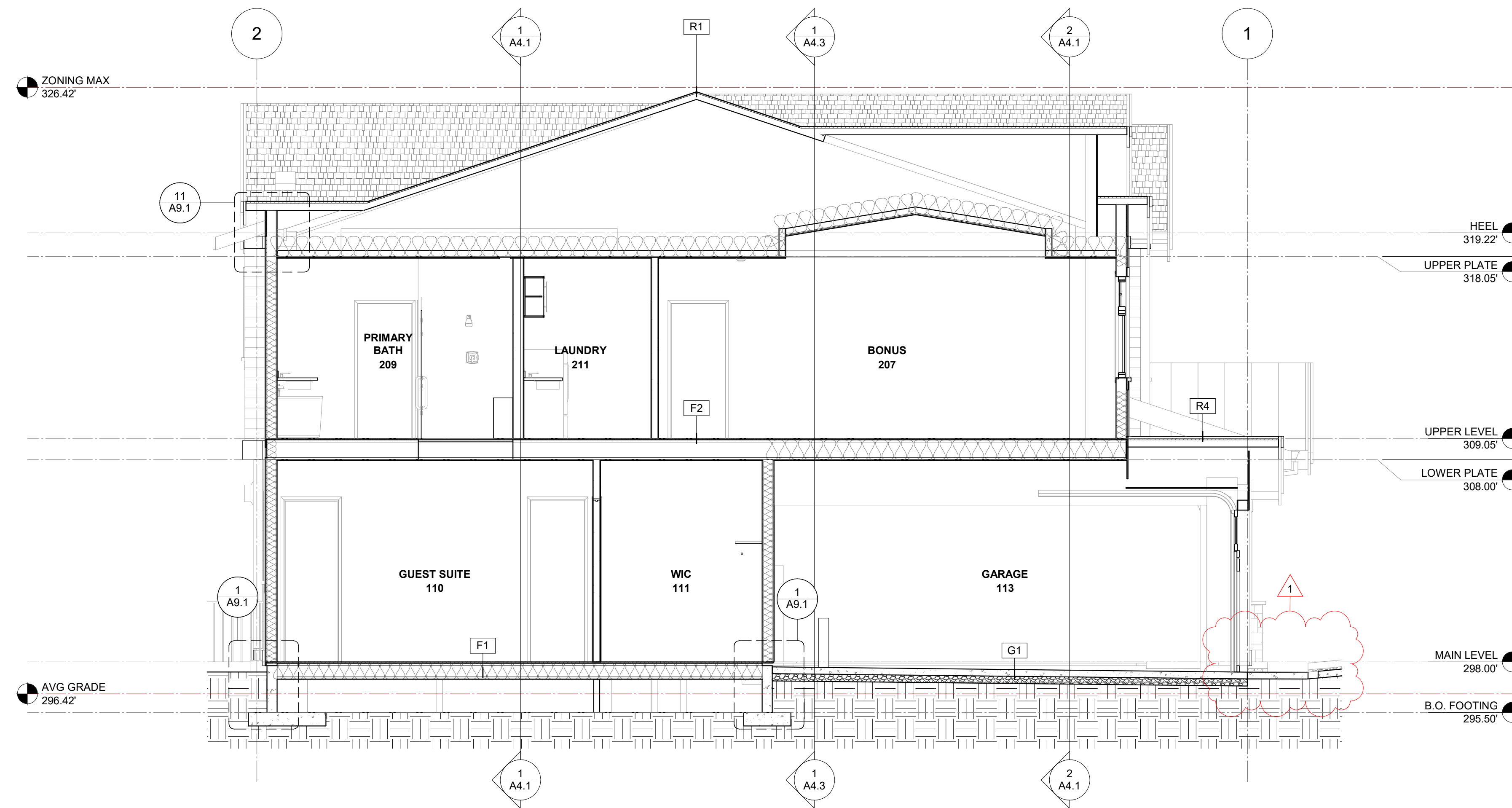

**2** OVERALL BUILDING SECTION V  
 A4.3 1/4" = 1'-0"

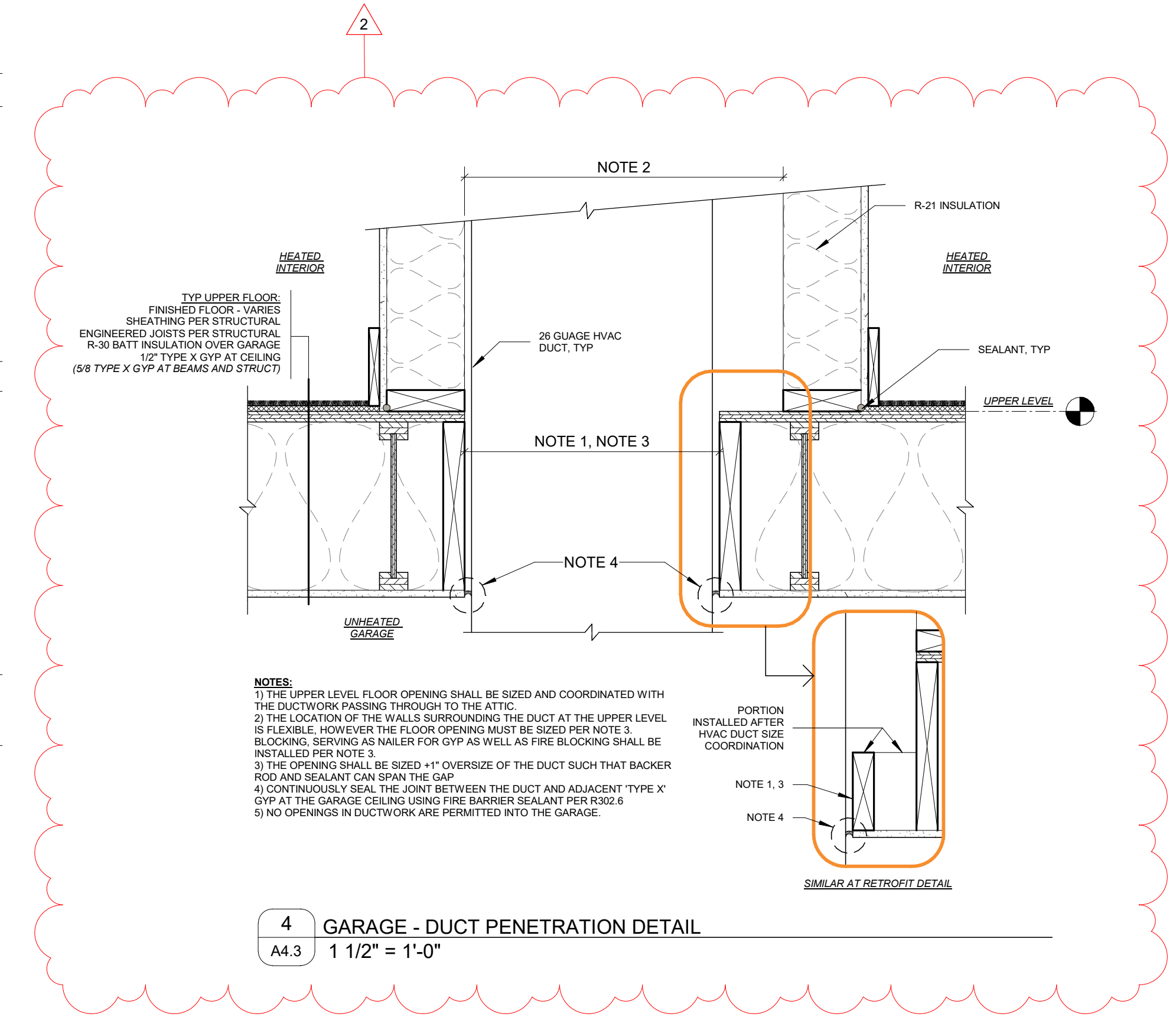

**4** GARAGE - DUCT PENETRATION DETAIL  
 A4.3 1 1/2" = 1'-0"

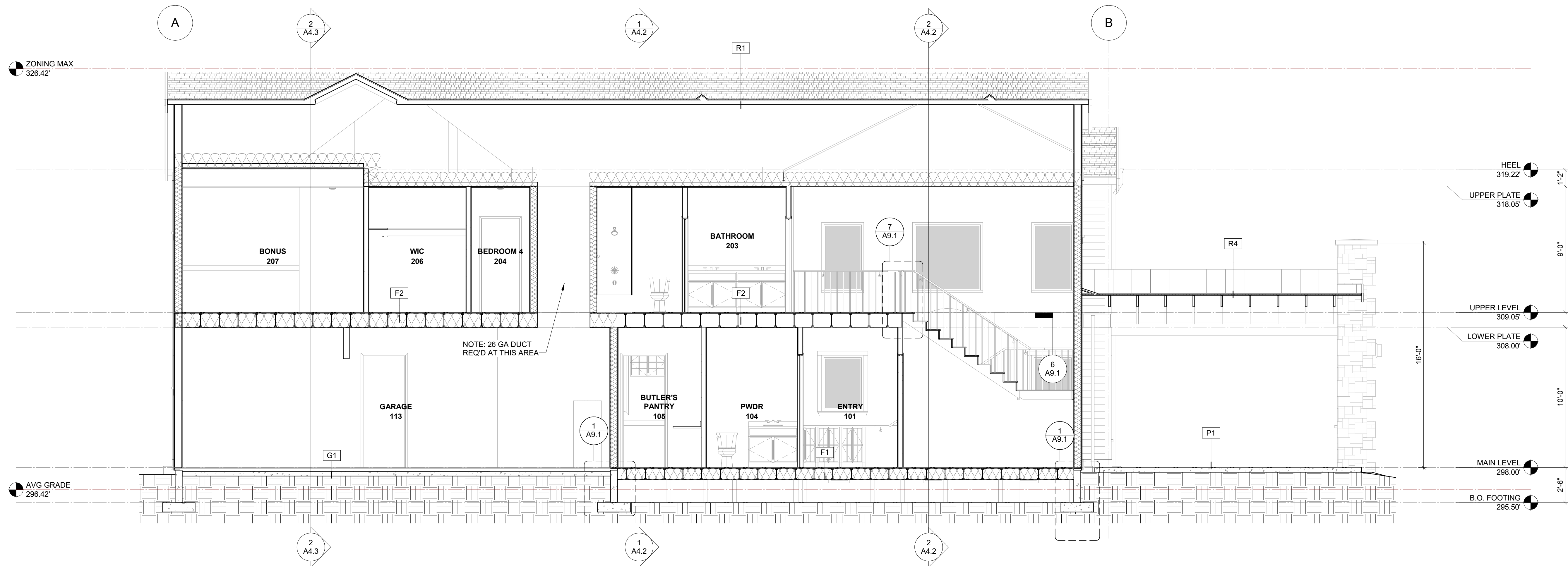

**1** OVERALL BUILDING SECTION VI  
 A4.3 1/4" = 1'-0"

CONSULTANT

STAMP

MN NO.

**MN472**

**7119 80TH AVE SE  
 MERCER ISLAND, WA 98040**

**BUILDING SECTIONS**

**REVISION HISTORY**

Δ	DATE	SUBMISSION
1	12-05-2023	REV 1
2	02-01-2024	REV 2

DATE: 04-12-2024

SCALE: AS NOTED

SET TYPE: PERMIT

SHEET NUMBER

**A4.3**



REVISION HISTORY

Δ	DATE	SUBMISSION
2	02-01-2024	REV 2

DATE: 04-12-2024

SCALE: AS NOTED

SET TYPE: PERMIT

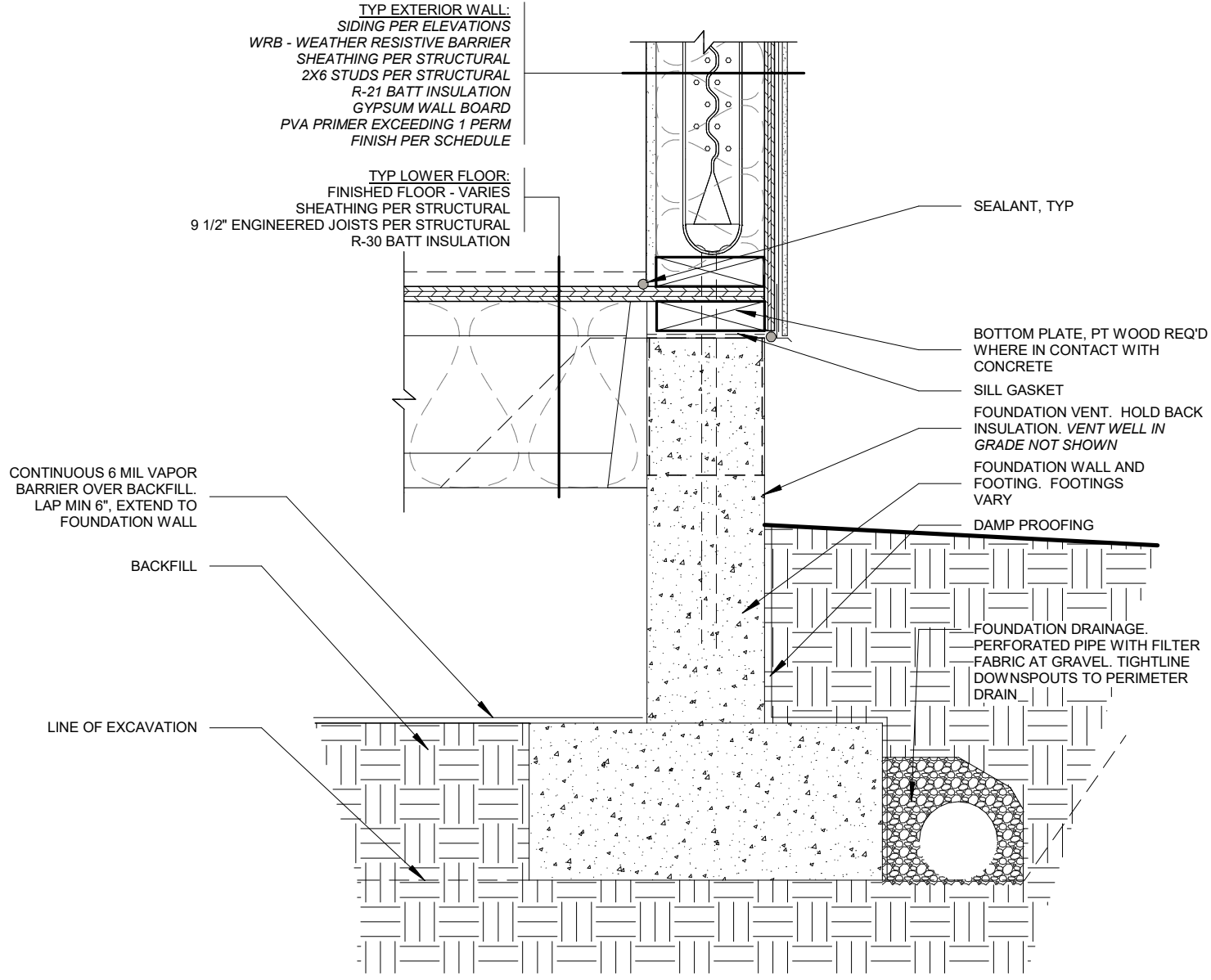
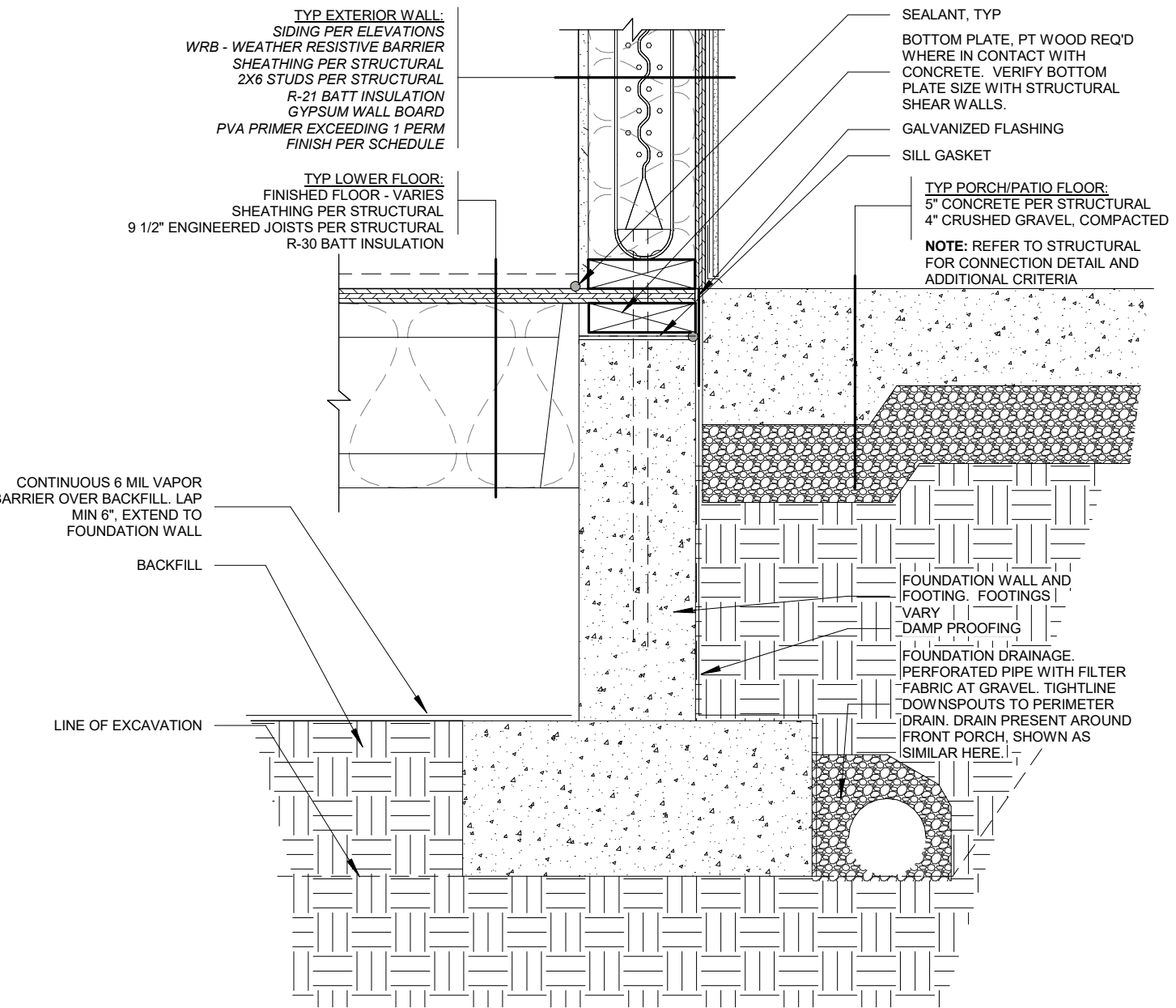
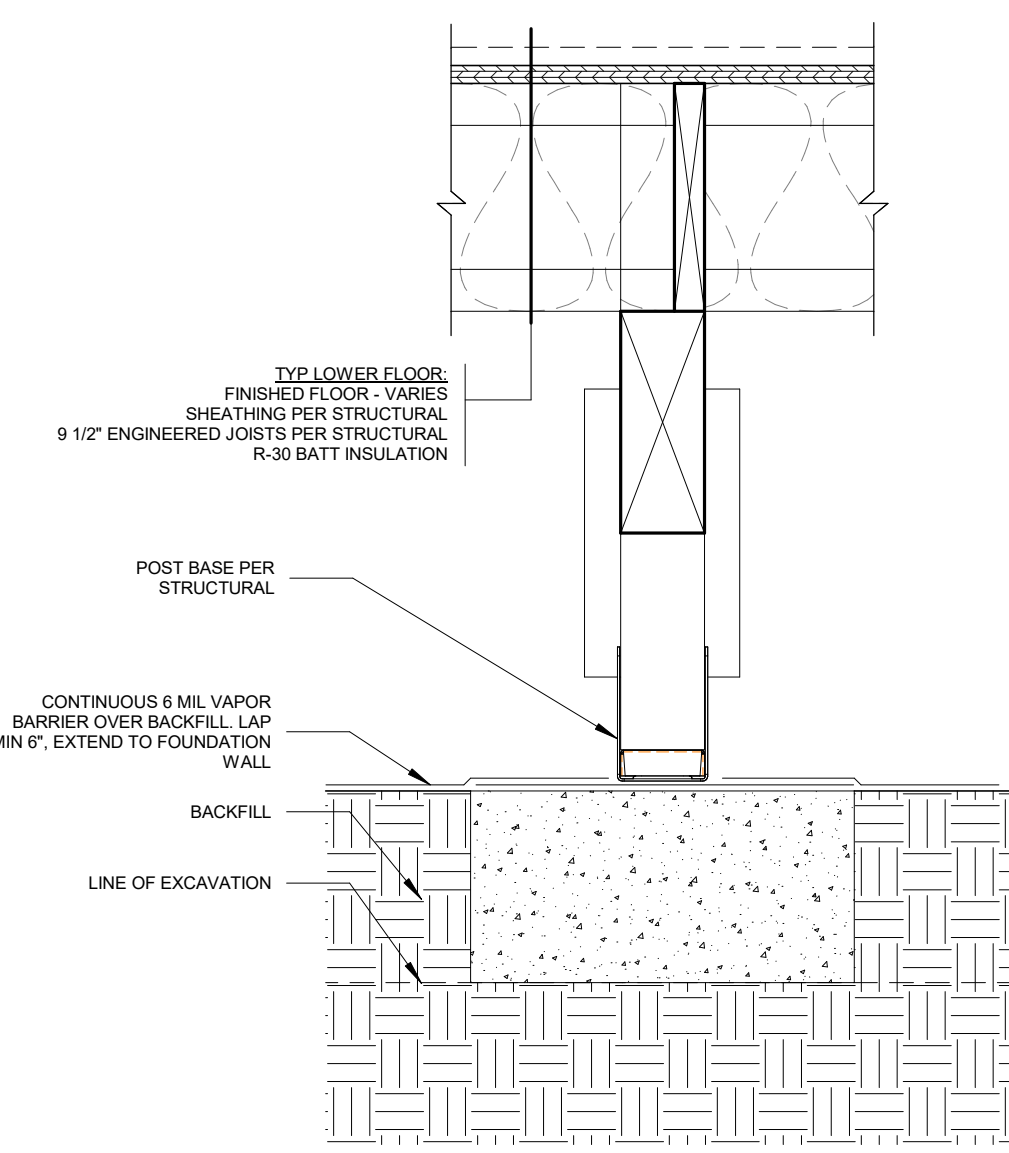
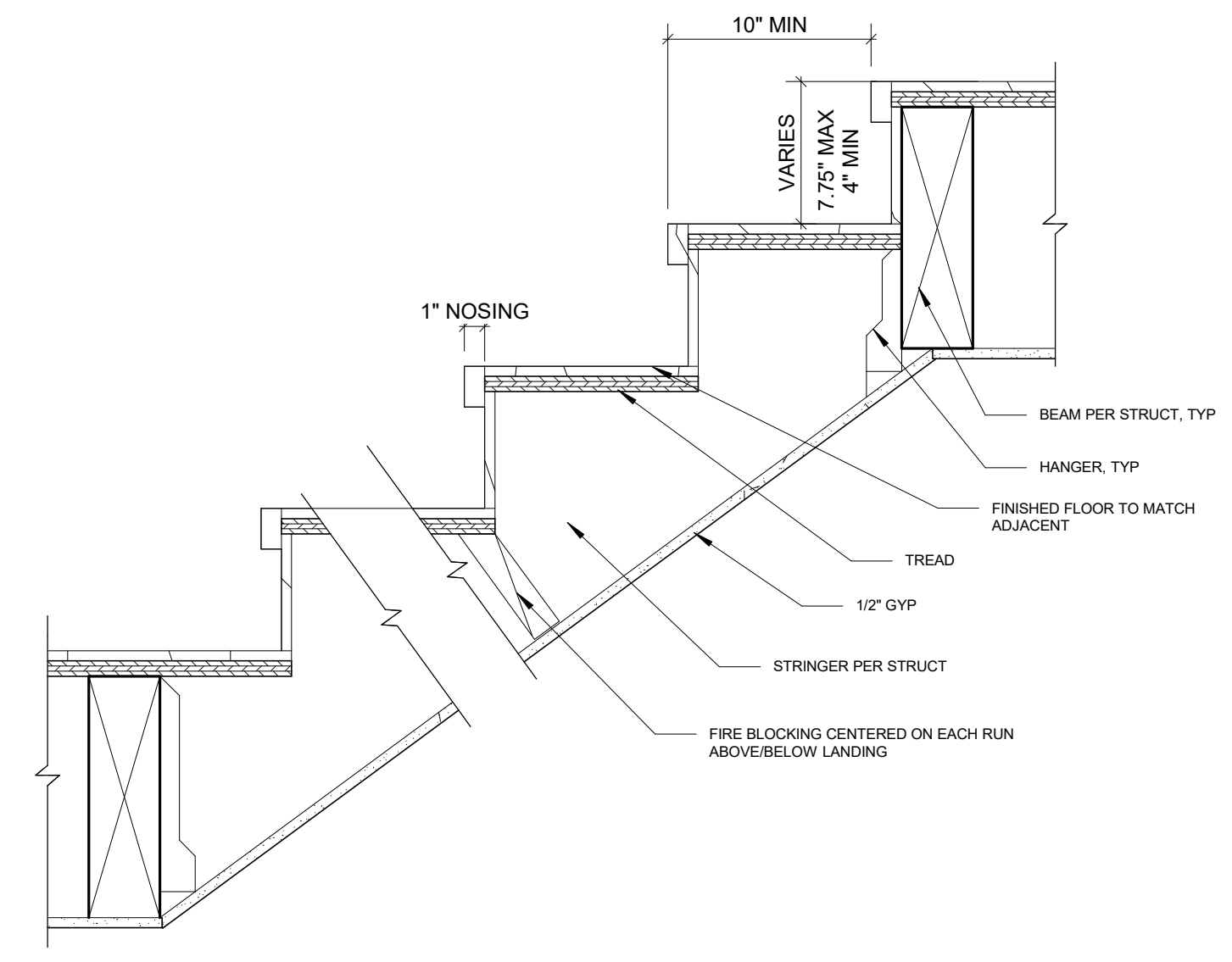
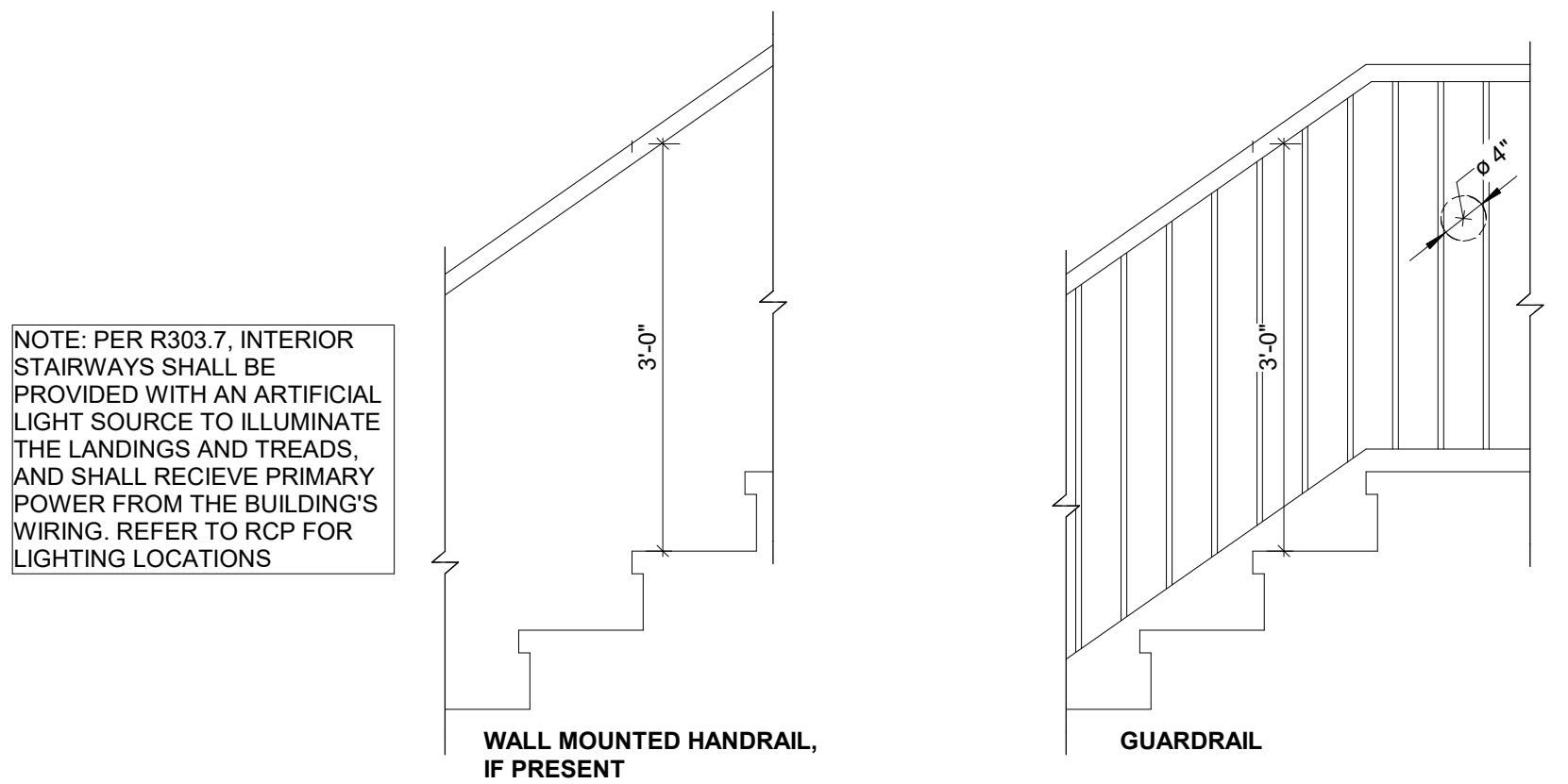
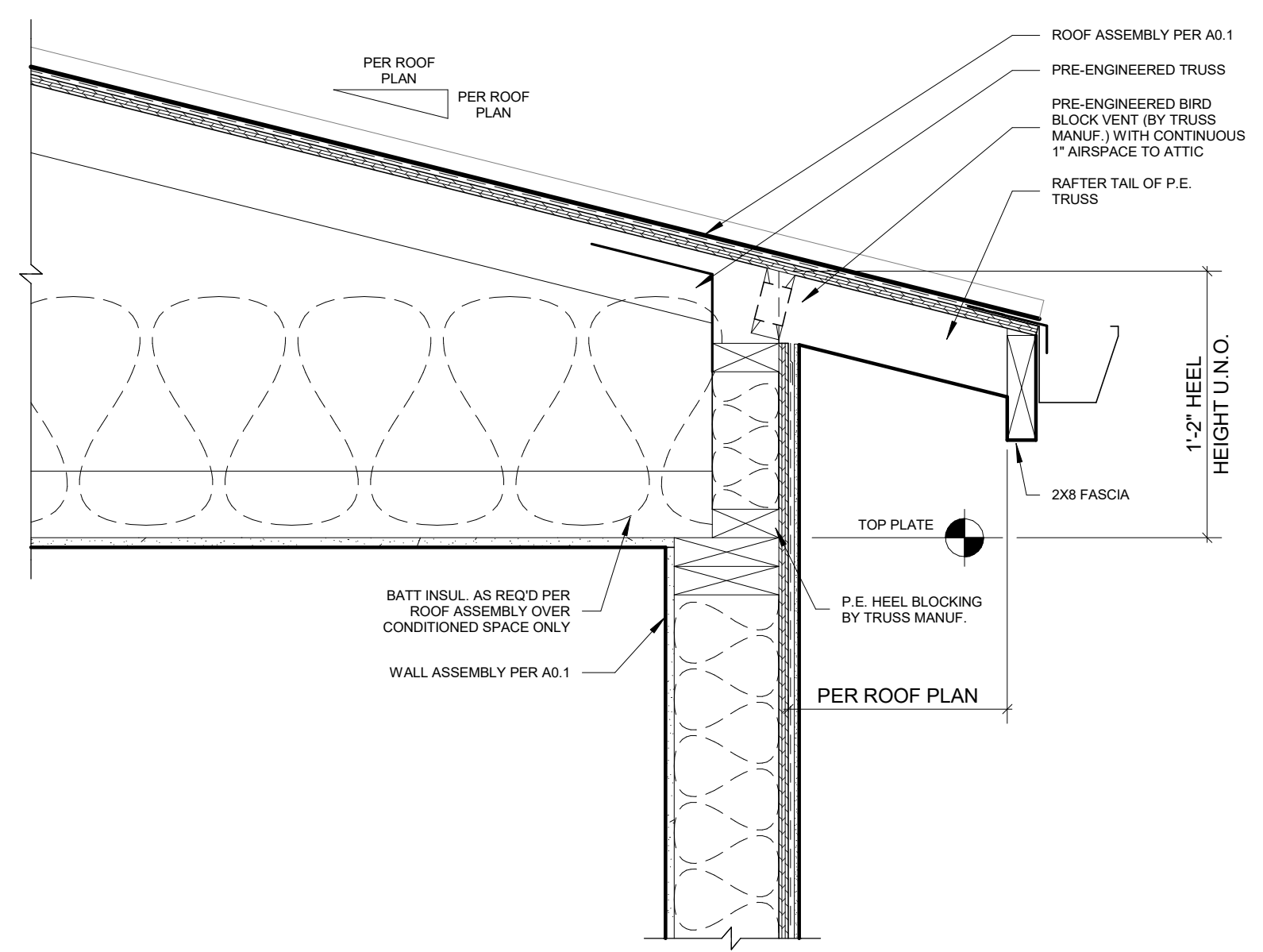
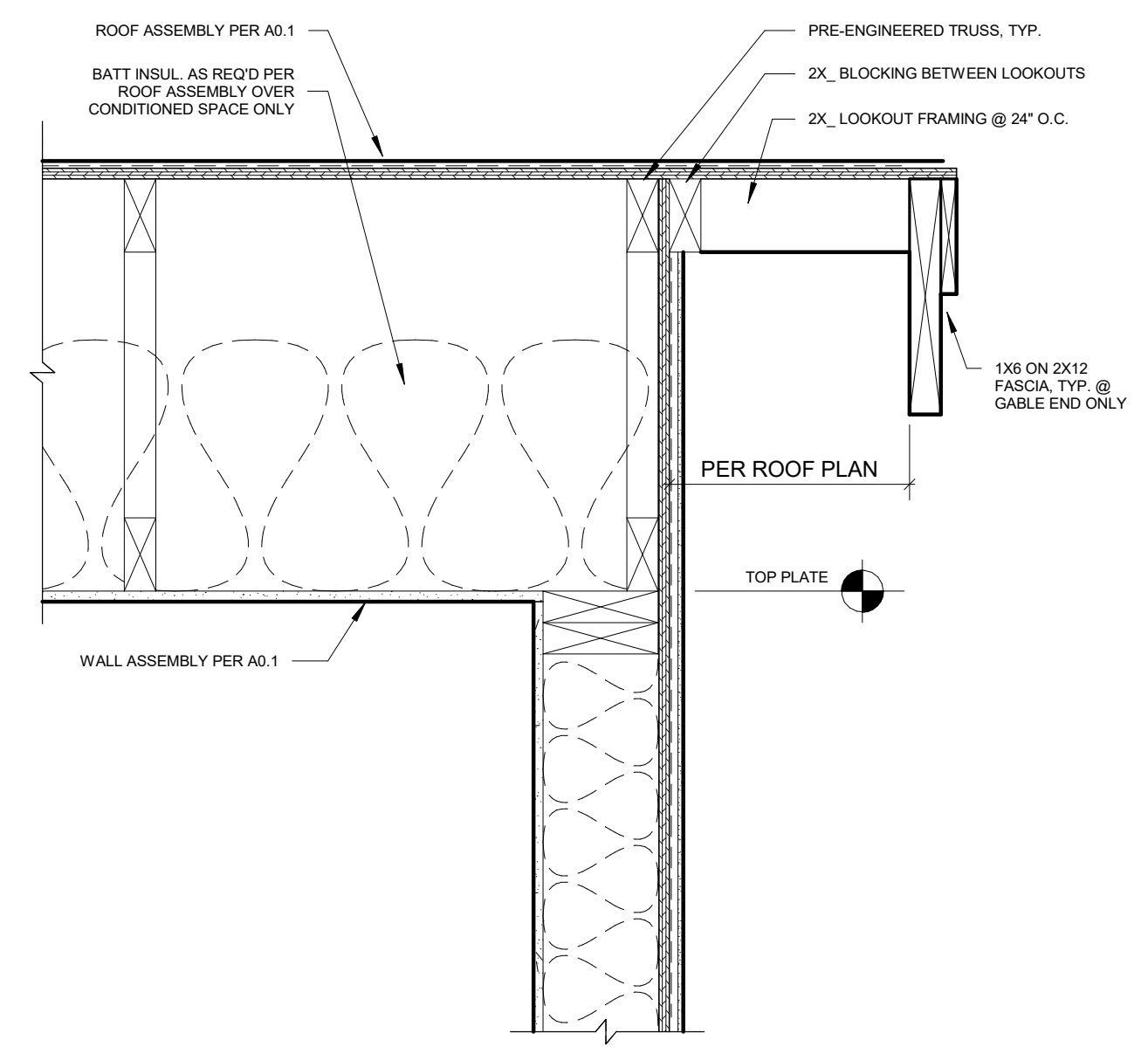
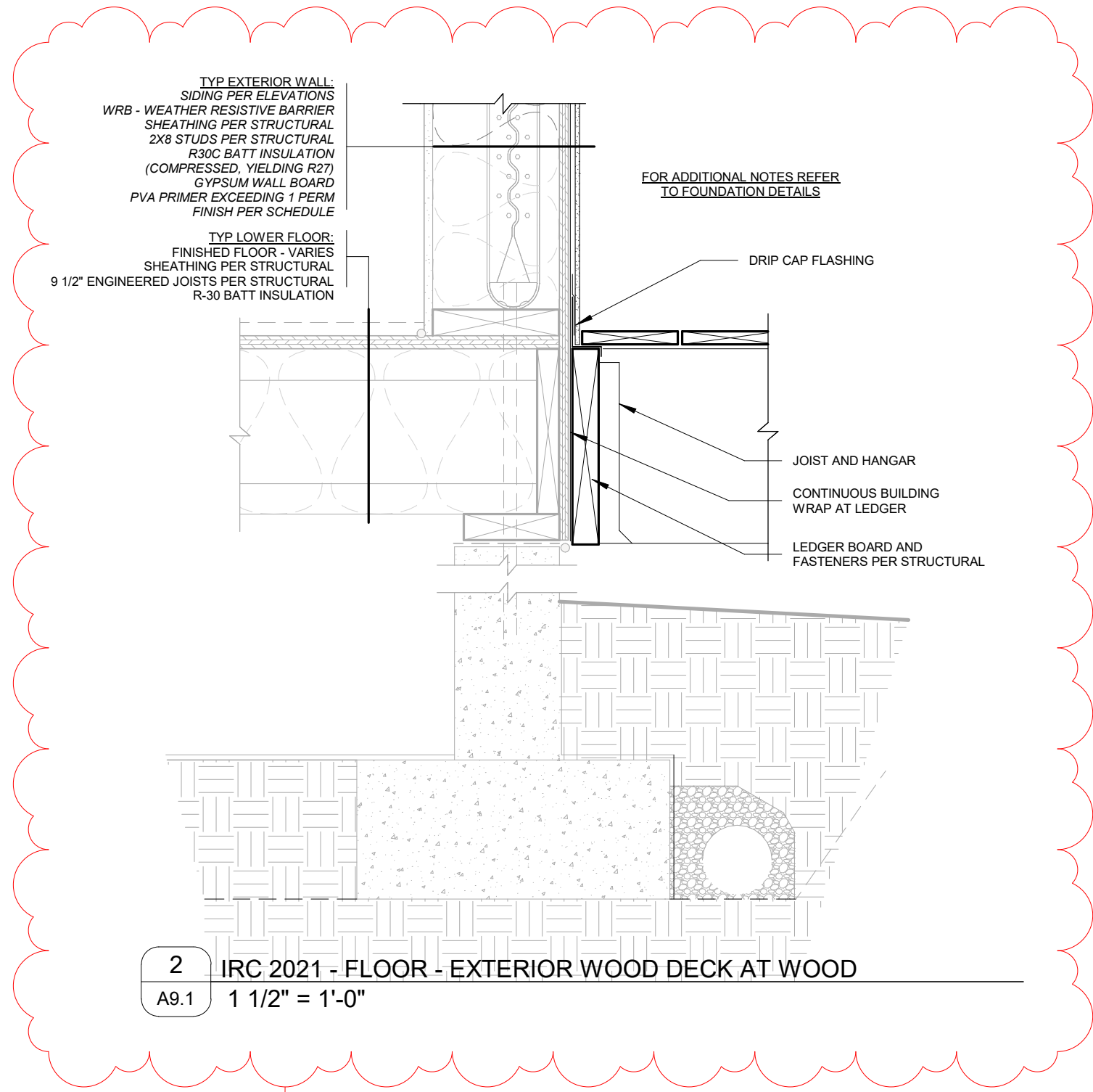







# GENERAL STRUCTURAL NOTES

THE FOLLOWING APPLY UNLESS SHOWN OTHERWISE ON THE DRAWINGS

## CRITERIA

- ALL MATERIALS, WORKMANSHIP, DESIGN, AND CONSTRUCTION SHALL CONFORM TO THE DRAWINGS, SPECIFICATIONS, AND THE INTERNATIONAL BUILDING CODE (IBC) 2018 EDITION.
- DESIGN LOADING CRITERIA  
FLOOR LIVE LOAD (RESIDENTIAL) 40 PSF  
FLOOR LIVE LOAD (RESIDENTIAL DECKS AND BALCONIES) 60 PSF  
SNOW 25 PSF  
WIND METHOD - DIRECTIONAL PROCEDURE  
Kz=1.44, GcPj=0.18, 98 MPH (RISK CATEGORY II), EXPOSURE "B"  
ANALYSIS PROCEDURE: EQUIVALENT LATERAL FORCE PROCEDURE  
LATERAL SYSTEM: LIGHT FRAMED SHEAR WALLS  
SDC D, SITE CLASS C, Ie=1.0, Ss=1.60, S1=0.50,  
Sds=1.280, Sd1=0.197, Cs=0.197, R=6.5,  
SEISMIC DESIGN BASE SHEAR Vsx=30.05 KIPS

3. STRUCTURAL DRAWINGS SHALL BE USED IN CONJUNCTION WITH ARCHITECTURAL DRAWINGS FOR BIDDING AND CONSTRUCTION. CONTRACTOR SHALL VERIFY DIMENSIONS AND CONDITIONS FOR COMPATIBILITY AND SHALL NOTIFY ARCHITECT OF ANY DISCREPANCIES PRIOR TO CONSTRUCTION.

4. PRIMARY STRUCTURAL ELEMENTS NOT DIMENSIONED ON THE STRUCTURAL PLANS AND DETAILS SHALL BE LOCATED BY THE ARCHITECTURAL PLANS AND DETAILS. VERTICAL DIMENSION CONTROL IS DEFINED BY THE ARCHITECTURAL WALL SECTIONS, BUILDING SECTIONS, AND PLANS. DETAILING AND SHOP DRAWING PRODUCTION FOR STRUCTURAL ELEMENTS WILL REQUIRE DIMENSIONAL INFORMATION CONTAINED IN BOTH ARCHITECTURAL AND STRUCTURAL DRAWINGS.

5. CONTRACTOR SHALL PROVIDE TEMPORARY BRACING FOR THE STRUCTURE AND STRUCTURAL COMPONENTS UNTIL ALL FINAL CONNECTIONS HAVE BEEN COMPLETED IN ACCORDANCE WITH THE PLANS. CONFORM TO ASCE 37-14 "DESIGN LOADS ON STRUCTURES DURING CONSTRUCTION."

6. CONTRACTOR SHALL BE RESPONSIBLE FOR ALL SAFETY PRECAUTIONS AND THE METHODS, TECHNIQUES, SEQUENCES OR PROCEDURES REQUIRED TO PERFORM THE CONTRACTOR'S WORK. THE STRUCTURAL ENGINEER HAS NO OVERALL SUPERVISORY AUTHORITY OR ACTUAL AND/OR DIRECT RESPONSIBILITY FOR THE SPECIFIC WORKING CONDITIONS AT THE SITE AND/OR FOR ANY HAZARDS RESULTING FROM THE ACTIONS OF ANY TRADE CONTRACTOR. THE STRUCTURAL ENGINEER HAS NO DUTY TO INSPECT, SUPERVISE, NOTE, CORRECT, OR REPORT ANY HEALTH OR SAFETY DEFICIENCIES TO THE OWNER, CONTRACTORS, OR OTHER ENTITIES OR PERSONS AT THE PROJECT SITE.

7. CONTRACTOR-INITIATED CHANGES SHALL BE SUBMITTED IN WRITING TO THE ARCHITECT AND STRUCTURAL ENGINEER FOR APPROVAL PRIOR TO FABRICATION OR CONSTRUCTION. CHANGES SHOWN ON SHOP DRAWINGS ONLY WILL NOT SATISFY THIS REQUIREMENT.

8. DRAWINGS INDICATE GENERAL AND TYPICAL DETAILS OF CONSTRUCTION. WHERE CONDITIONS ARE NOT SPECIFICALLY INDICATED BUT ARE OF SIMILAR CHARACTER TO DETAILS SHOWN, SIMILAR DETAILS OF CONSTRUCTION SHALL BE USED, SUBJECT TO REVIEW AND APPROVAL BY THE ARCHITECT AND THE STRUCTURAL ENGINEER.

9. ALL STRUCTURAL SYSTEMS WHICH ARE TO BE COMPOSED OF COMPONENTS TO BE FIELD ERRECTED SHALL BE SUPERVISED BY THE SUPPLIER DURING MANUFACTURING, DELIVERY, HANDLING, STORAGE, AND ERECTION IN ACCORDANCE WITH INSTRUCTIONS PREPARED BY THE SUPPLIER. MANUFACTURERS INSTALLATION INSTRUCTIONS SHALL BE AVAILABLE ON THE JOB SITE AT THE TIME OF INSPECTION FOR THE INSPECTORS USE AND REFERENCE.

## GEOTECHNICAL

10. SUBGRADE PREPARATION INCLUDING DRAINAGE, EXCAVATION, COMPACTION, AND FILLING REQUIREMENTS SHALL CONFORM STRICTLY WITH RECOMMENDATIONS GIVEN IN THE SOILS REPORT OR AS DIRECTED BY THE SOILS ENGINEER. FOOTINGS SHALL BEAR ON SOLID UNDISTURBED EARTH AT LEAST 18" BELOW LOWEST ADJACENT FINISHED GRADE. FOOTING DEPTHS/ELEVATIONS SHOWN ON PLANS (OR IN DETAILS) ARE MINIMUM AND FOR GUIDANCE ONLY; THE ACTUAL ELEVATIONS OF FOOTINGS MUST BE ESTABLISHED BY THE CONTRACTOR IN THE FIELD WORKING WITH THE TESTING LAB AND SOILS ENGINEER. BACKFILL BEHIND ALL RETAINING WALLS WITH FREE DRAINING GRANULAR FILL AND PROVIDE FOR SUBSURFACE DRAINAGE AS NOTED IN THE SOILS REPORT.

ALLOWABLE SOIL PRESSURE	2000 PSF
LATERAL EARTH PRESSURE (RESTRAINED/UNRESTRAINED)	45 PCF/35 PCF
PASSIVE PRESSURE	250 PCF
COEFFICIENT OF FRICTION	0.35

SOILS REPORT REFERENCE:  
INFILTRATION ASSESSMENT AND SOIL DESIGN RECOMMENDATIONS FOR MN472 - 7119 80TH AVE SE, MERCER ISLAND, WASHINGTON PREPARED BY SOUTH FORK GEOSCIENCES, PLLC ON JUNE 25TH 2023

## CONCRETE

11. CONCRETE SHALL BE MIXED, PROPORTIONED, CONVEYED AND PLACED IN ACCORDANCE WITH ACI 318 AND ACI 301, INCLUDING TESTING PROCEDURES. CONCRETE SHALL ATTAIN A 28-DAY STRENGTH OF Fc = 3000 PSI. SLUMP OF CONCRETE SHALL NOT EXCEED 6". STRUCTURAL DESIGN IS BASED ON A CONCRETE STRENGTH OF Fc = 2500 PSI, THEREFORE NO CONCRETE STRENGTH TESTING REQUIRED. CONCRETE EXPOSURE CATEGORIES ARE F1, S0, W0, AND C1.

ALL CONCRETE WITH SURFACES EXPOSED TO STANDING WATER SHALL BE AIR-ENTRAINED WITH AN AIR-ENTRAINING AGENT CONFORMING TO ASTM C260. TOTAL AIR CONTENT FOR FROST-RESISTANT CONCRETE SHALL BE IN ACCORDANCE WITH ACI 318-14, TABLE 19.3.3.1.

12. REINFORCING STEEL SHALL CONFORM TO ASTM A615, GRADE 60, fy = 60 KSI. EXCEPTIONS: ANY BARS SPECIFICALLY SO NOTED ON THE DRAWINGS SHALL BE GRADE 40, fy = 40 KSI. WELDED WIRE WIRE FABRIC SHALL CONFORM TO ASTM A1064. SPIRAL REINFORCEMENT SHALL BE DEFORMED WIRE CONFORMING TO ASTM A615, GRADE 60, fy = 60 KSI.

13. DETAILING OF REINFORCING STEEL (INCLUDING HOOKS AND BENDS) SHALL BE IN ACCORDANCE WITH ACI 315-99 AND 318-14. LAP ALL CONTINUOUS REINFORCEMENT #6 AND SMALLER 48 BAR DIAMETERS OR 2'-0" MINIMUM. PROVIDE CORNER BARS AT ALL WALL AND FOOTING INTERSECTIONS. LAP CORNER BARS #5 AND SMALLER 48 BAR DIAMETERS OR 2'-0" MINIMUM. LAPS OF LARGER BARS SHALL BE MADE IN ACCORDANCE WITH ACI 318-14, CLASS B. LAP ADJACENT MATS OF WELDED WIRE FABRIC A MINIMUM OF 8" AT SIDES AND ENDS.

NO BARS PARTIALLY EMBEDDED IN HARDENED CONCRETE SHALL BE FIELD BENT UNLESS SPECIFICALLY SO DETAILED OR APPROVED BY THE STRUCTURAL ENGINEER.

14. CONCRETE PROTECTION (COVER) FOR REINFORCING STEEL SHALL BE AS FOLLOWS:

FOOTINGS AND OTHER UNFORMED SURFACES CAST AGAINST AND PERMANENTLY EXPOSED TO EARTH	3"
FORMED SURFACES EXPOSED TO EARTH OR WEATHER (#6 BARS OR LARGER)	2"
FORMED SURFACES EXPOSED TO EARTH OR WEATHER (#5 BARS OR SMALLER)	1-1/2"
COLUMN TIES OR SPIRALS AND BEAM STIRRUPS	1-1/2"
SLABS AND WALLS (INT FACE)	GREATER OF BAR DIAMETER PLUS 1/8" OR 3/4"

## ANCHORAGE

15. EPOXY-GROUTED ITEMS (THREADED RODS OR REINFORCING BAR) SPECIFIED ON THE DRAWINGS SHALL BE INSTALLED USING "SET-XP" EPOXY ADHESIVE AS MANUFACTURED BY THE SIMPSON STRONG TIE COMPANY. INSTALL IN STRICT ACCORDANCE WITH ICC-ES REPORT ESR-2508 AND IAPMO-UES REPORT ESR-265. SUBSTITUTIONS PROPOSED BY THE CONTRACTOR SHALL BE SUBMITTED FOR REVIEW WITH CURRENT ICC REPORTS INDICATING EQUIVALENT OR GREATER LOAD CAPACITIES. SPECIAL INSPECTION OF INSTALLATION IS REQUIRED. RODS SHALL BE ASTM A36, UNO.

16. HEAVY DUTY THREADED CONCRETE ANCHORS SPECIFIED ON THE DRAWINGS SHALL BE "TITEN HD SCREW ANCHOR" AS MANUFACTURED BY THE SIMPSON STRONG TIE COMPANY. INSTALL IN STRICT ACCORDANCE WITH ICC-ES REPORT ESR-2713 AND ESR-1056, INCLUDING MINIMUM EMBEDMENT AND EDGE DISTANCE REQUIREMENTS. SUBSTITUTIONS PROPOSED BY THE CONTRACTOR SHALL BE SUBMITTED FOR REVIEW WITH CURRENT ICC REPORTS INDICATING EQUIVALENT OR GREATER LOAD CAPACITIES. SPECIAL INSPECTION OF INSTALLATION IS REQUIRED.

17. EXPANSION BOLTS INTO CONCRETE AND CONCRETE MASONRY UNITS SHALL BE "STRONG-BOLT 2" ANCHORS AS MANUFACTURED BY THE SIMPSON STRONG TIE COMPANY. INSTALL IN STRICT CONFORMANCE TO ICC-ES REPORT ESR-3037 AND IAPMO-UES REPORT ESR-240, INCLUDING MINIMUM EMBEDMENT AND EDGE DISTANCE REQUIREMENTS. SUBSTITUTIONS PROPOSED BY THE CONTRACTOR SHALL BE SUBMITTED FOR REVIEW WITH CURRENT ICC REPORTS INDICATING EQUIVALENT OR GREATER LOAD CAPACITIES. BOLTS INTO CONCRETE MASONRY OR BRICK MASONRY UNITS SHALL BE INTO FULLY GROUTED CELLS. SPECIAL INSPECTION OF INSTALLATION IS REQUIRED.

18. DRIVE PINS AND OTHER POWDER-ACTUATED FASTENERS SHALL BE LOW VELOCITY TYPE (PDPWL-300MG, 0.145" DIAMETER, UNO) AS MANUFACTURED BY THE SIMPSON STRONG TIE COMPANY OR AN APPROVED EQUIVALENT IN STRENGTH AND EMBEDMENT. INSTALL IN STRICT ACCORDANCE WITH ICC-ES REPORT ESR-2138. MINIMUM EMBEDMENT IN CONCRETE SHALL BE 1", UNO. MAINTAIN AT LEAST 3" TO NEAREST CONCRETE EDGE.

## WOOD

19. ALL 2x LUMBER SHALL BE KILN DRIED OR MC-19, AND ALL LUMBER SHALL BE GRADED AND MARKED IN CONFORMANCE WITH WCLB STANDARD GRADING RULES FOR WEST COAST LUMBER NO 17. FURNISH TO THE FOLLOWING MINIMUM STANDARDS:

JOISTS AND BEAMS	(2x AND 3x MEMBERS)	HEM-FIR NO 2 OR SPRUCE-PINE-FIR NO 2 MINIMUM BASE VALUE, Fb = 850 PSI
	(4x MEMBERS)	DOUGLAS FIR-LARCH NO 2 MINIMUM BASE VALUE, Fb = 900 PSI
BEAMS	(6x AND LARGER)	DOUGLAS FIR-LARCH NO 2 MINIMUM BASE VALUE, Fb = 875 PSI
POSTS	(4x MEMBERS)	DOUGLAS FIR-LARCH NO 2 MINIMUM BASE VALUE, Fc = 1350 PSI
	(6x AND LARGER)	DOUGLAS FIR-LARCH NO 2 MINIMUM BASE VALUE, Fc = 600 PSI
STUDS, PLATES AND MISC FRAMING		HEM-FIR NO 2 OR SPRUCE-PINE-FIR NO 2

20. GLUED LAMINATED MEMBERS SHALL BE FABRICATED IN CONFORMANCE WITH ASTM AND ANSI/AITC STANDARDS. EACH MEMBER SHALL BEAR AN AITC OR APA-EWS IDENTIFICATION MARK AND SHALL BE ACCOMPANIED BY AN AITC OR APA-EWS CERTIFICATE OF CONFORMANCE. ALL SIMPLE SPAN GLULAM BEAMS SHALL BE DOUGLAS FIR COMBINATION 24F-V4, Fb = 2400 PSI, Fv = 265 PSI, E = 1800 KSI, UNO. ALL CANTILEVER GLULAM BEAMS SHALL BE DOUGLAS FIR COMBINATION 24F-V8, Fb = 2400 PSI, Fv = 265 PSI, E = 1800 KSI, UNO. GLUED LAMINATED COLUMNS SHALL BE DOUGLAS FIR COMBINATION 3, L2D GRADE, Fc = 2300 PSI, Fb = 2000 PSI, E = 1900 KSI.

21. MANUFACTURED LUMBER AND LVL SHALL BE MANUFACTURED UNDER A PROCESS APPROVED BY THE NATIONAL RESEARCH BOARD. EACH PIECE SHALL BEAR A STAMP OR STAMPS NOTING THE NAME AND PLANT NUMBER OF THE MANUFACTURER, THE GRADE, THE NATIONAL RESEARCH BOARD NUMBER, AND THE QUALITY CONTROL AGENCY. ALL LVL AND LUMBER SHALL BE MANUFACTURED IN ACCORDANCE WITH ICC-ES REPORT ESR-1387 USING DOUGLAS FIR VENEER GLUED WITH A WATERPROOF ADHESIVE MEETING THE REQUIREMENTS OF ASTM D2559 WITH ALL GRAIN PARALLEL WITH THE LENGTH OF THE MEMBER. THE MEMBERS SHALL HAVE THE FOLLOWING MINIMUM PROPERTIES:

1-1/4"	Fb = 600 PSI	E = 550 KSI	Fv = 270 PSI
1-3/4" / 3-1/2"	Fb = 2250 PSI	E = 1600 KSI	Fv = 220 PSI
5-1/4" / 7"	Fb = 3100 PSI	E = 2100 KSI	Fv = 290 PSI
LVL COLUMN (1.8E)	Fb = 3000 PSI	E = 1800 KSI	Fv = 285 PSI

DESIGN SHOWN ON PLANS IS BASED ON LUMBER MANUFACTURED BY THE TRUS-JOIST CORPORATION. ALTERNATE MANUFACTURERS MAY BE USED SUBJECT TO REVIEW AND APPROVAL BY THE ARCHITECT AND STRUCTURAL ENGINEER. ALTERNATE JOIST HANGERS AND OTHER HARDWARE MAY BE SUBSTITUTED FOR ITEMS SHOWN PROVIDED THEY HAVE CURRENT ICC APPROVAL FOR EQUAL OR GREATER LOAD CAPACITIES. ALL JOIST HANGERS AND OTHER HARDWARE SHALL BE COMPATIBLE IN SIZE WITH MEMBERS PROVIDED.

MANUFACTURED LUMBER PRODUCTS SHALL BE INSTALLED WITH A MOISTURE CONTENT OF 12% OR LESS. THE CONTRACTOR SHALL MAKE PROVISIONS DURING CONSTRUCTION TO PREVENT THE MOISTURE CONTENT OF INSTALLED BEAMS FROM EXCEEDING 12%. EXCESSIVE DEFLECTIONS MAY OCCUR IF MOISTURE CONTENT EXCEEDS THIS VALUE.

22. PREFABRICATED PLYWOOD WEB JOIST DESIGN SHOWN ON PLANS IS BASED ON JOISTS MANUFACTURED BY THE ROSEBURG CORPORATION. ALTERNATE PLYWOOD WEB JOIST MANUFACTURERS MAY BE USED SUBJECT TO REVIEW AND APPROVAL BY THE ARCHITECT AND STRUCTURAL ENGINEER. ALTERNATE JOIST HANGERS AND OTHER HARDWARE MAY BE SUBSTITUTED FOR ITEMS SHOWN PROVIDED THEY HAVE CURRENT ICC APPROVAL FOR EQUAL OR GREATER LOAD CAPACITIES. ALL JOIST HANGERS AND OTHER HARDWARE SHALL BE COMPATIBLE IN SIZE WITH PLYWOOD WEB JOIST PROVIDED.

23. PLYWOOD SHEATHING SHALL BE GRADE C-D, EXTERIOR GLUE OR STRUCTURAL II, EXTERIOR GLUE IN CONFORMANCE WITH DDC PS-1 OR PS-2, ORIENTED STRAND BOARD OF EQUIVALENT THICKNESS, EXPOSURE RATING AND PANEL INDEX MAY BE USED IN LIEU OF PLYWOOD.

WALL SHEATHING SHALL BE 7/16" or 1/2" (NOMINAL) WITH SPAN RATING 24/0
FLOOR SHEATHING SHALL BE 3/4" T&G (NOMINAL) WITH SPAN RATING 48/24
WATERPROOF DECK SHEATHING SHALL BE 3/4" T&G (NOMINAL) WITH SPAN RATING 48/24
FLAT ROOF SHEATHING SHALL BE 3/4" T&G (NOMINAL) WITH SPAN RATING 48/24
ROOF SHEATHING SHALL BE 1/2" or 7/16" (NOMINAL) WITH SPAN RATING 32/16 FOR ROOFS WITH A PITCH GREATER THAN 2:12
REFER TO WOOD FRAMING NOTES BELOW FOR TYPICAL NAILING REQUIREMENTS.

24. ALL WOOD IN DIRECT CONTACT WITH CONCRETE OR MASONRY SHALL BE PRESSURE-TREATED WITH AN APPROVED PRESERVATIVE OR (2) LAYERS OF ASPHALT IMPREGNATED BUILDING PAPER SHALL BE PROVIDED BETWEEN UNTREATED WOOD AND CONCRETE OR MASONRY.

25. PRESSURE TREATED WOOD (INCLUDES PRESERVATIVE AND FIRE TREATED) SHALL BE TREATED PER AWPA STANDARDS. PRESSURE TREATED WOOD FOR ABOVE GROUND USE SHALL BE TREATED TO RETENTION OF 0.25 PCF. WOOD IN CONTINUOUS CONTACT WITH FRESH WATER OR SOIL SHALL BE TREATED TO A RETENTION OF 0.40 PCF. SODIUM BORATE (SBX) TREATED WOOD SHALL NOT BE USED WHERE EXPOSED TO WEATHER. FASTENERS AND TIMBER CONNECTORS WITHOUT AMMONIA IN DIRECT CONTACT WITH ACQ-A TO A RETENTION LEVEL OF 0.40 PCF, CBA-A (UP TO A RETENTION LEVEL OF 0.41 PCF), CA-B (UP TO A RETENTION LEVEL OF 0.21 PCF), SHALL BE G185 OR A185 HOT DIPPED OR CONTINUOUS HOT-GALVANIZED PER ASTM A653. FASTENERS AND TIMBER CONNECTORS WITH AMMONIA IN DIRECT CONTACT WITH ACQ-A (OVER A RETENTION LEVEL OF 0.40 PCF), CBA-A (OVER A RETENTION LEVEL OF 0.41 PCF), CA-B (OVER A RETENTION LEVEL OF 0.21 PCF), OR WITH ACZA TREATED WOOD SHALL BE TYPE 304 OR 316 STAINLESS STEEL.

26. TIMBER CONNECTORS CALLED OUT BY LETTERS AND NUMBERS SHALL BE "STRONG-TIE" BY SIMPSON COMPANY, AS SPECIFIED IN THEIR CATALOG NUMBER C-C-2019. EQUIVALENT DEVICES BY OTHER MANUFACTURERS MAY BE SUBSTITUTED, PROVIDED THEY HAVE CURRENT ICC APPROVAL FOR EQUAL OR GREATER LOAD CAPACITIES. PROVIDE NUMBER AND SIZE OF FASTENERS AS SPECIFIED BY MANUFACTURER. CONNECTORS SHALL BE INSTALLED IN ACCORDANCE WITH THE MANUFACTURER'S RECOMMENDATIONS.

ALL 2x JOISTS SHALL BE CONNECTED TO FLUSH BEAMS WITH "LUS" SERIES JOIST HANGERS. ALL TJI JOISTS SHALL BE CONNECTED TO FLUSH BEAMS WITH "IUS" SERIES JOIST HANGERS. ALL DOUBLE-JOISTS BEAMS SHALL BE CONNECTED TO FLUSH BEAMS WITH "MIU" SERIES JOIST HANGERS.

WHERE CONNECTOR STRAPS CONNECT (2) MEMBERS, PLACE ONE-HALF OF THE NAILS OR BOLTS IN EACH MEMBER.

ALL SHIMS SHALL BE SEASONED AND DRIED AND THE SAME GRADE (MINIMUM) AS MEMBERS CONNECTED.

## 27. WOOD FASTENERS

A. NAIL SIZES SPECIFIED ON DRAWINGS ARE BASED ON THE FOLLOWING SPECIFICATIONS:

SIZE	TYPE	LENGTH	DIAMETER
8d	COMMON	2-1/2"	0.131"
10d	GUN	3"	0.131"
12d	GUN	3-1/4"	0.131"
16d	GUN	3-1/2"	0.131"

IF CONTRACTOR PROPOSES THE USE OF ALTERNATE NAILS, THEY SHALL SUBMIT NAIL SPECIFICATIONS TO THE STRUCTURAL ENGINEER (PRIOR TO CONSTRUCTION) FOR REVIEW AND APPROVAL.

NAILS - PLYWOOD (APA RATED SHEATHING) FASTENERS TO FRAMING SHALL BE DRIVEN FLUSH TO FACE OF SHEATHING WITH NO COUNTERSINKING PERMITTED.

B. ALL BOLTS IN WOOD MEMBERS SHALL CONFORM TO ASTM A307. PROVIDE WASHERS UNDER THE HEADS AND NUTS OF ALL BOLTS AND LAG BOLTS BEARING ON WOOD. INSTALLATION OF LAG SCREWS SHALL CONFORM TO THE NATIONAL DESIGN SPECIFICATION FOR WOOD CONSTRUCTION (2018 EDITION) WITH A LEAD BORE HOLE OF 60-70% OF THE SHANK DIAMETER. LEAD HOLES ARE NOT REQUIRED FOR 3/8" AND SMALLER LAG SCREWS. BOLT HOLES SHALL BE A MINIMUM OF 1/32" TO A MAXIMUM OF 1/16" LARGER THAN THE BOLT DIAMETER. HOLES SHALL BE ACCURATELY ALIGNED IN MAIN MEMBERS AND SIDE PLATES/MEMBERS. BOLTS SHALL NOT BE FORCIBLY DRIVEN.

C. SDS AND SDWS SCREWS CALLED OUT ON PLAN ARE TIMBER SCREWS MANUFACTURED BY SIMPSON STRONG-TIE COMPANY. SCREWS SHALL BE INSTALLED IN ACCORDANCE WITH THE MANUFACTURERS RECOMMENDATIONS. EQUIVALENT SCREWS BY OTHER MANUFACTURERS MAY BE SUBSTITUTED, PROVIDED THEY HAVE CURRENT ICC APPROVAL FOR EQUAL OR GREATER LOAD CAPACITIES. LAG SCREWS ARE NOT AN EQUIVALENT SUBSTITUTION.

## 28. WOOD FRAMING NOTES - THE FOLLOWING APPLY UNLESS NOTED OTHERWISE ON THE PLANS:

A. ALL WOOD FRAMING DETAILS NOT SHOWN OTHERWISE SHALL BE CONSTRUCTED TO THE MINIMUM STANDARDS OF THE IBC, THE AITC "TIMBER CONSTRUCTION MANUAL", AND THE AF&PA "NATIONAL DESIGN SPECIFICATION FOR WOOD CONSTRUCTION". MINIMUM NAILING SHALL CONFORM TO TABLE 2304.10.1. OF THE IBC, UNO. COORDINATE THE SIZE AND LOCATION OF ALL OPENINGS WITH ARCHITECTURAL AND MECHANICAL DRAWINGS.

B. WALL FRAMING: REFER TO ARCHITECTURAL DRAWINGS FOR THE SIZE OF ALL WALLS. ALL STUDS SHALL BE SPACED AT 16"oc, UNO. (2) STUDS MINIMUM SHALL BE PROVIDED AT THE END OF ALL WALLS AND AT EACH SIDE OF ALL OPENINGS, AND AT BEAM OR HEADER BEARING LOCATIONS. (2) 2x8 HEADERS SHALL BE PROVIDED OVER ALL OPENINGS IN STRUCTURAL WALLS, UNO. NAIL MULTI-MEMBER HEADERS WITH (2) ROWS 10d AT 12"oc. SOLID BLOCKING FOR WOOD COLUMNS SHALL BE PROVIDED THROUGH FLOORS TO SUPPORTS BELOW. PROVIDE CONTINUOUS SOLID BLOCKING AT MID-HEIGHT OF ALL STUD WALLS OVER 10'-0" IN HEIGHT.

ALL WALLS SHALL HAVE A SINGLE BOTTOM PLATE AND A DOUBLE TOP PLATE. END NAIL TOP PLATE AND BOTTOM PLATE TO EACH STUD WITH (3) 10d NAILS. FACE NAIL DOUBLE TOP PLATES WITH 10d AT 12"oc AND LAP MINIMUM 4'-0" AT JOINTS AND PROVIDE (12) 10d NAILS AT 4"oc EACH SIDE OF JOINT. AT TOP PLATE INTERSECTIONS PROVIDE (3) 10d FACE NAILS.

ALL STUD WALLS SHALL HAVE THEIR LOWER WOOD PLATES ATTACHED TO WOOD FRAMING BELOW WITH (2) ROWS OF 12d NAILS AT 16"oc, OR ATTACHED TO CONCRETE BELOW WITH 5/8" DIAMETER ANCHOR BOLTS AT 4'-0"oc EMBEDDED 7" MINIMUM, UNO. THERE SHALL BE A MINIMUM OF (2) BOLTS PER PLATE SECTION WITH (1) BOLT LOCATED NOT MORE THAN 12" OR LESS THAN 4-1/2" FROM EACH END OF THE PLATE SECTION. INDIVIDUAL MEMBERS OF BUILT-UP STUDS SHALL BE NAILED EACH OTHER WITH (2) ROWS OF 10d AT 16"oc. UNLESS NOTED OTHERWISE, GYPSUM WALLBOARD SHALL BE FASTENED TO THE INTERIOR SURFACE OF ALL STUDS AND PLATES WITH #6 x 1-1/4" TYPE S OR W SCREWS AT 12"oc. UNLESS NOTED OTHERWISE, 7/16" OR 1/2" (NOMINAL) APA RATED SHEATHING (SPAN RATING 24/0) SHALL BE NAILED TO ALL EXTERIOR SURFACES WITH 8d NAILS AT 6"oc AT PANEL EDGES AND TOP AND BOTTOM PLATES (BLOCK UN-SUPPORTED EDGES) AND TO ALL INTERMEDIATE STUDS AND BLOCKING WITH 8d NAILS AT 12"oc. ALLOW 1/8" SPACING AT ALL PANEL EDGES AND PANEL ENDS.

C. FLOOR AND ROOF FRAMING: PROVIDE DOUBLE JOISTS UNDER ALL PARALLEL PARTITIONS THAT EXTEND OVER MORE THAN HALF THE JOIST LENGTH AND AROUND ALL OPENINGS IN FLOORS OR ROOFS, UNO. PROVIDE SOLID BLOCKING AT ALL BEARING POINTS. TOENAIL TIMBER JOISTS TO SUPPORTS WITH (3) 10d NAILS AND NAIL TJI JOISTS TO SUPPORTS WITH (2) 10d NAILS. ATTACH JOISTS TO BEAMS WITH SIMPSON JOIST HANGERS IN ACCORDANCE WITH NOTES ABOVE. NAIL ALL MULTI-JOIST BEAMS TOGETHER WITH (2) ROWS 10d AT 12"oc. TOENAIL RIM JOIST TO TOP PLATE WITH 10d AT 6"oc. TOENAIL BLOCKING BETWEEN JOISTS TO TOP PLATE WITH (3) 10d NAILS.

UNLESS NOTED OTHERWISE ON THE PLANS, PLYWOOD ROOF AND FLOOR SHEATHING SHALL BE LAID UP WITH GRAIN PERPENDICULAR TO SUPPORTS WITH END JOINTS STAGGERED, AND NAILED AT 6"oc WITH 8d NAILS TO FRAMED PANEL EDGES, STRUTS AND OVER STUD WALLS AS SHOWN ON PLANS AND AT 12"oc TO INTERMEDIATE SUPPORTS. PROVIDE APPROVED PLYWOOD EDGE CLIPS CENTERED BETWEEN JOISTS/TRUSSES AT UNBLOCKED ROOF SHEATHING EDGES. ALL FLOOR SHEATHING EDGES SHALL HAVE APPROVED T&G JOINTS OR SHALL BE SUPPORTED WITH SOLID BLOCKING. ALLOW 1/8" SPACING AT ALL PANEL EDGES AND ENDS OF FLOOR AND ROOF SHEATHING. TOENAIL BLOCKING TO SUPPORTS WITH 10d AT 12"oc, UNO.

## 29. NOTCHES AND HOLES IN WOOD FRAMING:

A. SAWN LUMBER JOISTS AND RAFTERS: NOTCHES AT THE ENDS OF JOISTS SHALL NOT EXCEED 1/4 THE JOIST DEPTH. NOTCHES IN THE TOP OR BOTTOM OF JOISTS SHALL NOT EXCEED 1/6 THE JOIST DEPTH, BE LONGER THAN 1/3 THE JOIST DEPTH, OR BE LOCATED IN THE MIDDLE 1/3 OF THE SPAN. HOLES SHALL NOT BE WITHIN 2" OF THE TOP OR BOTTOM OF THE JOIST AND THE DIAMETER SHALL NOT EXCEED 1/3 THE JOIST DEPTH. SPACING BETWEEN HOLES SHALL BE A MINIMUM OF (2) TIMES THE DIAMETER OF THE LARGEST HOLE OR 2" AND SHALL BE LOCATED A MINIMUM OF 2" FROM ANY NOTCH.

B. EXTERIOR AND BEARING WALLS: WOOD STUDS ARE PERMITTED TO BE NOTCHED TO A DEPTH NOT EXCEEDING 1/4 OF ITS WIDTH. A HOLE NOT GREATER IN DIAMETER THAN 40% OF THE STUD WIDTH IS PERMITTED IN WOOD STUDS. HOLES SHALL NOT BE WITHIN 5/8" TO THE EDGE OF THE STUD. SPACING BETWEEN HOLES SHALL BE A MINIMUM OF (2) TIMES THE DIAMETER OF THE LARGEST HOLE OR 2" AND SHALL NOT BE LOCATED AT THE SAME SECTION AS A NOTCH.

C. CUTS, NOTCHES, AND HOLES IN MANUFACTURED LUMBER, PREFABRICATED PLYWOOD WEB JOISTS, AND PREFABRICATED TRUSSES ARE PROHIBITED EXCEPT WHERE NOTED ON STRUCTURAL PLANS OR PERMITTED BY MANUFACTURER'S RECOMMENDATIONS.

30. ELECTRICAL, MECHANICAL, PLUMBING, AND DRAINAGE SYSTEMS SHALL BE DESIGNED TO ACCOMMODATE THE DIFFERENTIAL SHRINKAGE OR MOVEMENT OF THE WOOD STRUCTURE (3/8" PER FLOOR).

31. DEFLECTION OF CANTILEVERS SHALL BE CLOSELY MONITORED BY THE CONTRACTOR DURING CONSTRUCTION. CONTRACTOR TO VERIFY AND ENSURE ALL POST CAPS AND POST BEARING CONDITIONS ARE INSTALLED IN STRICT CONFORMANCE TO THE STRUCTURAL PLANS. CANTILEVERS IN WOOD FRAMING CAN DEFLECT UP TO 1/8" PER FOOT (I.E. A CANTILEVER MAY DEFLECT 1/2"). IF DEFLECTION EXCEEDS 1/8" PER FOOT NOTIFY STRUCTURAL ENGINEER IMMEDIATELY. BEFORE FINISHES ARE INSTALLED, FLOORS AT OR ABOVE CANTILEVERS MAY REQUIRE LEVELING COMPOUND AND SOFFITS FURRED TO MAKE THEM LEVEL.

32. PREFABRICATED CONNECTOR PLATE WOOD ROOF TRUSSES SHALL BE DESIGNED BY THE MANUFACTURER IN ACCORDANCE WITH THE "NATIONAL DESIGN STANDARD FOR METAL PLATE-CONNECTED WOOD TRUSS CONSTRUCTION", ANSI/TPI 1 BY THE TRUSS PLATE INSTITUTE FOR THE SPANS AND CONDITIONS SHOWN ON THE PLANS. LOADING SHALL BE AS FOLLOWS:

TOP CHORD LIVE LOAD	25 PSF
TOP CHORD DEAD LOAD	15 PSF
BOTTOM CHORD DEAD LOAD	5 PSF
TOTAL LOAD	45 PSF

WIND UPLIFT (TOP CHORD)	10 PSF
BOTTOM CHORD LIVE LOAD	10 PSF
(BOTTOM CHORD LIVE LOAD DOES NOT ACT CONCURRENTLY WITH THE ROOF LIVE LOAD)	

REFER TO PLAN FOR ADDITIONAL LOADING

TRUSSES SHALL BE DESIGNED TO NOT ALLOW LIMITED STORAGE PER IBC TABLE 1607.1. WEBS SHALL BE CONFIGURED SO THAT ALL OPENINGS ARE SMALLER THAN 24" WIDE x 42" HIGH.

WOOD TRUSSES SHALL UTILIZE APPROVED CONNECTOR PLATES (GANGNAIL OR EQUAL). SUBMIT SHOP DRAWINGS AND DESIGN CALCULATIONS TO THE ARCHITECT AND STRUCTURAL ENGINEER FOR REVIEW PRIOR TO FABRICATION. SUBMITTED DOCUMENTS SHALL BE STAMPED AND SIGNED BY A STRUCTURAL ENGINEER REGISTERED IN THE STATE OF WASHINGTON. PROVIDE FOR CHANGES, BEARING POINTS, INTERSECTIONS, HIPS, VALLEYS, ETC. SHOWN ON THE DRAWINGS. EXACT COMPOSITION OF SPECIAL HIP, VALLEY, AND INTERSECTION AREAS, USE OF GIRDER TRUSSES, JACK TRUSSES, STEP-DOWN TRUSSES, ROOF OVER-FRAMING, ETC SHALL BE DETERMINED BY THE MANUFACTURER UNLESS SPECIFICALLY INDICATED ON THE PLANS. PROVIDE ALL TRUSS TO TRUSS AND TRUSS TO GIRDER TRUSS CONNECTION DETAILS AND REQUIRED CONNECTION MATERIALS. PROVIDE FOR ALL TEMPORARY AND PERMANENT TRUSS BRACING AND BRIDGING.

## ABBREVIATIONS

±	PLUS OR MINUS	GL	GLUE LAMINATED TIMBER	OSB	ORIENTED STRAND BOARD
Ø	DIAMETER	GR	GRADE	PLF	POUNDS PER LINEAR FOOT
ADDL	ADDITIONAL	GT	GIRDER TRUSS		PLYWOOD
ALT	ALTERNATE	GW	GYPSUM WALLBOARD	PLY	PREFABRICATED
APPROX	APPROXIMATE	HD	HOLDOWN	PREFAB	POUNDS PER SQUARE FOOT
ARCH	ARCHITECT, ARCHITECTURAL	HDR	HEADER	PSF	POUNDS PER SQUARE INCH
BLKG	BLOCKING	HGR	HANGER	PSI	PARALLEL STRAND LUMBER
BM	BEAM	HM	HIP MASTER		PRESSURE TREATED LUMBER
BOE	BOTTOM OF EXCAVATION	HORIZ	HORIZONTAL	PSL	REINFORCING
BOT	BOTTOM	IBC	INTERNATIONAL BUILDING CODE	PT	REQUIRED
CL	CENTERLINE	INT	INTERIOR	REQD	SLAB ON GRADE
CLR	CLEARANCE	IRC	INTERNATIONAL RESIDENTIAL CODE	SOG	SQUARE
CONT	CONTINUOUS	DOUBLE	DOUBLE	SO	STANDARD
DBL	DOUBLE	JST	JOIST	STD	SHEARWALL
DF	DOUGLAS FIR	K	KIPS (1000 LBS)	T&G	TONGUE AND GROOVE
DP	DEEP, DEPTH	KP	KING POST	THRD	THREADED
DN	DOWN	L	LENGTH	TRIPLE	TRANSVERSE
DS	DRAG STRUT	LONG	LONGITUDINAL	TP	TYPICAL
DWGS	DRAWINGS	LSL	LAMINATED	TRANSV	UNLESS NOTED OTHERWISE
(E)	EXISTING	LVL	STRUCTURAL LUMBER	UNO	VERTICAL
EA	EACH		LAMINATED VENEER LUMBER		WIDE OR WIDTH
EMBED	EMBEDMENT				WITH
EQ	EQUAL				WITHOUT
EQUIV	EQUIVALENT				WELDED HEADED STUD
EW	EACH WAY	MAX	MAXIMUM		WELDED THREADED STUD
EXP	EXPANSION	MB	MACHINE BOLT		WELDED WIRE MESH
EXT	EXTERIOR	MFR	MANUFACTURER		
FDN	FOUNDATION	MIN	MINIMUM		
FRMG	FRAMING	MISC	MISCELLANEOUS		
FT	FEET	NO	NUMBER		
FIG	FOOTING	NTS	NOT TO SCALE		
GA	GAUGE	oc	ON CENTER		
GALV	GALVANIZED	OPP	OPPOSITE		

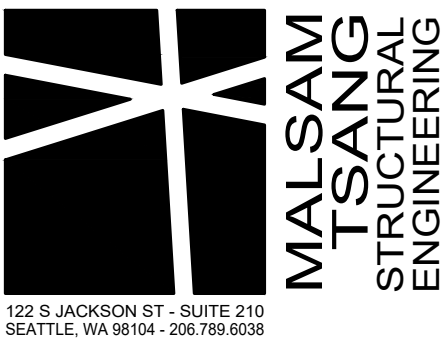

122 S. JACOBSON ST. SUITE 210 SEATTLE, WA 98104 • 206.787.0038

PLAN MN472

7119 80TH AVE SE  
MERCER ISLAND, WA 98040



PROJECT NO 0444.2023.09.01  
PROJECT MANAGER WAC  
DRAWN JAS  
ENGINEER GARRETT OSWALD  
206.902.7287  
GARRETTO@MALSAM-TSANG.COM

REV	DESCRIPTION	DATE
	PERMIT SET	7.12.23
△	PERMIT CORRECTIONS	12.01.23
△	PLAN REVISIONS	2.09.24

ARCH MN CUSTOM HOMES  
425.394.3848

## GENERAL STRUCTURAL NOTES

S1.0

SCALE - NTS



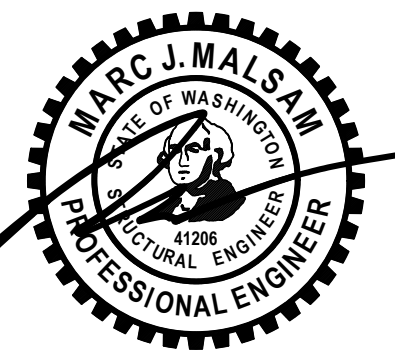

PROJECT NO 0444.2023.09.01  
PROJECT MANAGER WAC  
DRAWN JAS  
ENGINEER GARRETT OSWALD  
206.902.7287  
GARRETTO@MALSAM-TSANG.COM

REV	DESCRIPTION	DATE
	PERMIT SET	7.12.23
△	PERMIT CORRECTIONS	12.01.23
△	PLAN REVISIONS	2.09.24

ARCH MN CUSTOM HOMES  
425.394.3848

**MAIN FLOOR  
FRAMING AND  
FOUNDATION PLAN**

**S2.1A**

SCALE - 1/4" = 1'-0"

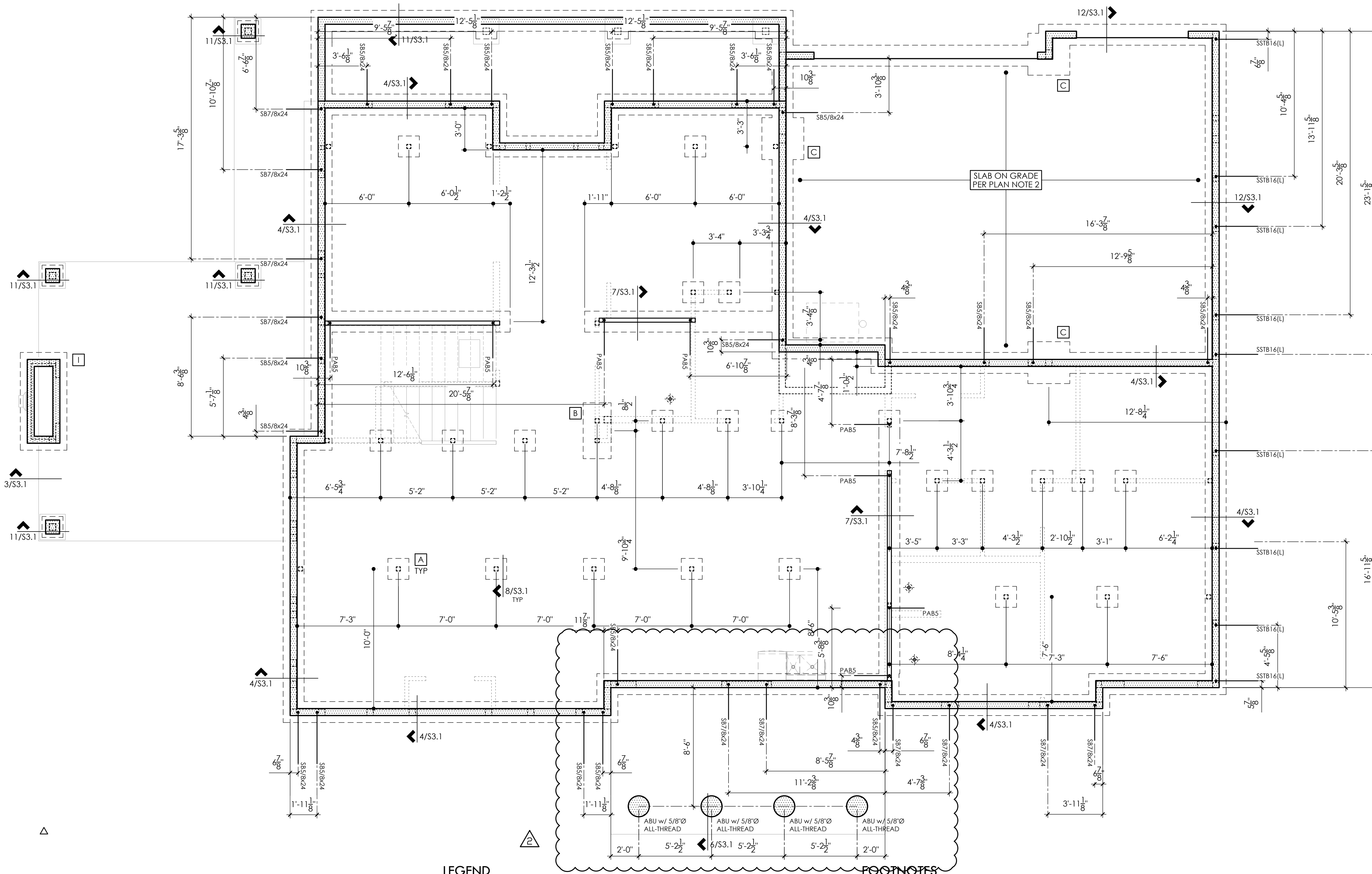

**PLAN NOTES**

1. BOTTOM OF ALL FOOTINGS SHALL BE 18" MINIMUM BELOW LOWEST ADJACENT GRADE, UNO.
2. SLAB ON GRADE SHALL BE 4" MINIMUM THICKNESS. REINFORCE WITH 6x6 W1.4 x W1.4 WWM CENTERED IN SLAB. PROVIDE VAPOR BARRIER BELOW SLAB OVER 4" MIN FREE DRAINING GRAVEL OVER FIRM NATIVE SOILS OR STRUCTURAL FILL PER SOILS ENGINEER.
3. REFER TO SHEET S3.0 FOR TYPICAL FOUNDATION AND CONCRETE DETAILS.
4. STDH HOLDOWNS ARE DIMENSIONED TO THE CENTERLINE OF STRAP. HDU HOLDOWNS ARE DIMENSIONED TO THE CENTERLINE OF ANCHOR BOLT. DIMENSIONS ARE BASED OFF OF DRAWINGS PROVIDED BY THE ARCHITECT AND SHOULD BE VERIFIED.
5. REFER TO GENERAL STRUCTURAL NOTES SHEET S1.0 FOR ADDITIONAL REQUIREMENTS.
6. DO NOT SCALE DRAWINGS. REFER TO ARCHITECTURAL DRAWINGS FOR ALL DIMENSIONS.

**LEGEND**

- CONCRETE WALL BELOW
- STRUCTURAL WALL ABOVE

**FOOTNOTES**

- ① NOT USED
- ② NOT USED
- ③ NOT USED

**FOUNDATION PLAN**

MAIN FLOOR WALLS SHOWN DASHED

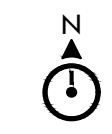

PROJECT NORTH

**FOOTING SCHEDULE**

MARK	SIZE	REINFORCING
A	1'-6" SQ x 8" DP	(3)#4 EW BOT
B	2'-0" W x 4'-0" L x 8" DP	(3)#4 BOT LONG (5)#4 BOT TRANSV
C	3'-0" SQ x 12" DP	(4)#4 EW BOT (5)#4 BOT TRANSV
I	3'-6" W x 7'-0" L x 12" DP	(5)#4 BOT LONG (10)#4 BOT TRANSV



COPYRIGHT © 2020 MALSAM TSANG ENGINEERING CORPORATION - ALL RIGHTS RESERVED

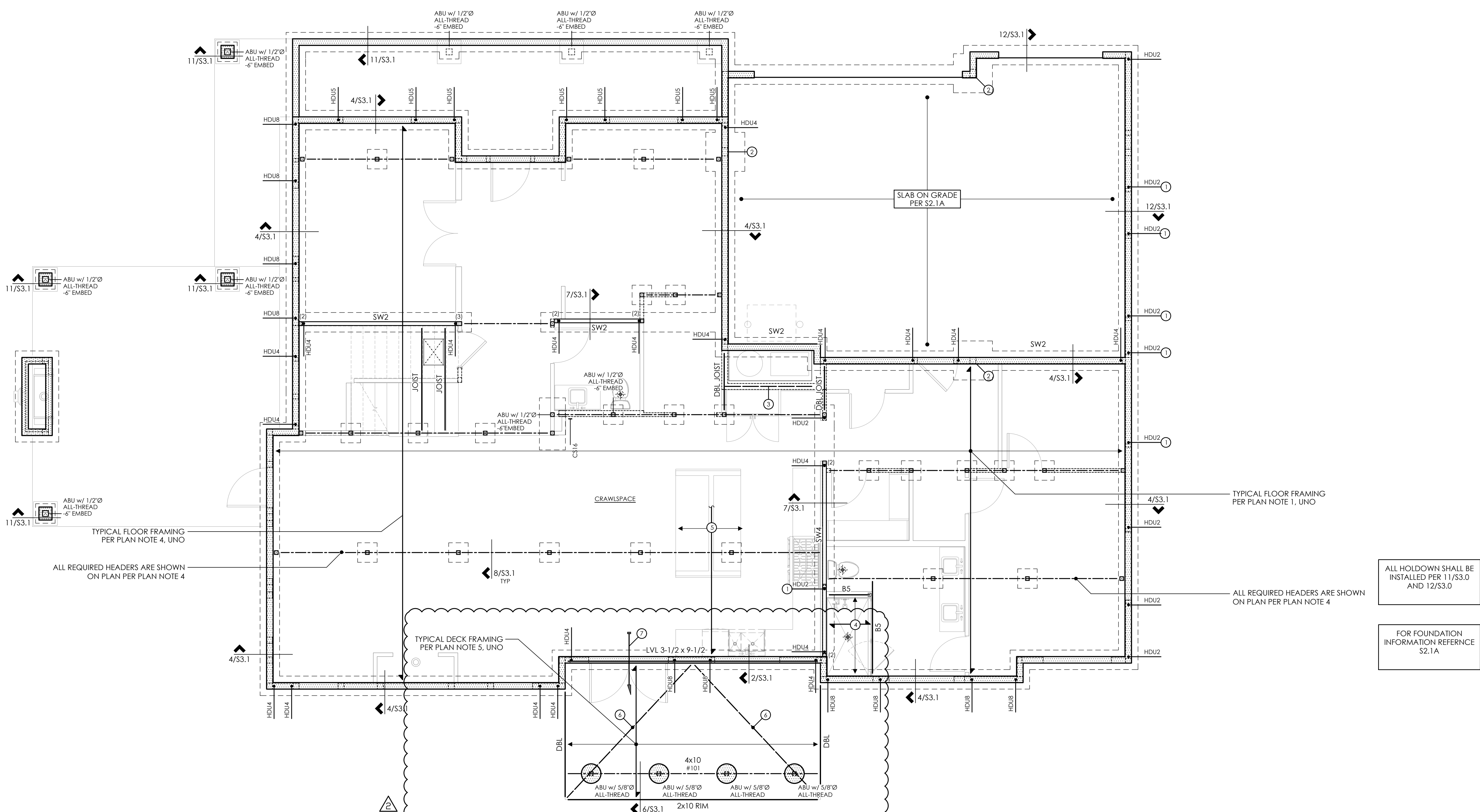

- PLAN NOTES**
- TYPICAL FLOOR FRAMING CONSISTS OF 3/4" T&G APA RATED SHEATHING (SPAN RATING 48/24) OVER 9'-1/2" RFPF 20's AT 16"oc, UNO. PROVIDE DOUBLE JOISTS UNDER ALL PARALLEL PARTITIONS THAT EXTEND OVER MORE THAN HALF THE JOIST LENGTH.
  - GLUE AND NAIL FLOOR SHEATHING w/ 8d AT 6"oc AT FRAMED PANEL EDGES AND AT 12"oc IN THE FIELD, UNO.
  - "SW" INDICATES SHEARWALL BELOW FRAMING SHOWN. REFER TO SHEARWALL SCHEDULE ON 4/S3.0 FOR ADDITIONAL INFORMATION. ALL EXTERIOR WALLS ARE SW6, UNO.
  - ALL HEADERS SHALL BE 4x10, UNO. PROVIDE PT 4x6 POST AT SPLICES, PT 4x4 POSTS ELSEWHERE, UNO. REFER TO DETAIL 8/S3.1 FOR ADDITIONAL REQUIREMENTS.
  - TYPICAL OPEN DECK FRAMING CONSISTS OF DECKING PER ARCH DRAWINGS OVER PT 2x10's AT 16"oc, UNO.
  - STD HOLDOWNS ARE DIMENSIONED TO THE CENTERLINE OF STRAP. HDU HOLDOWNS ARE DIMENSIONED TO THE CENTERLINE OF ANCHOR BOLT. DIMENSIONS ARE BASED OFF OF DRAWINGS PROVIDED BY THE ARCHITECT AND SHOULD BE VERIFIED.
  - REFER TO GENERAL STRUCTURAL NOTES SHEET S1.0 FOR ADDITIONAL REQUIREMENTS.
  - DO NOT SCALE DRAWINGS. REFER TO ARCHITECTURAL DRAWINGS FOR ALL DIMENSIONS.

- LEGEND**
- CONCRETE WALL BELOW
  - STRUCTURAL WALL ABOVE
  - SPAN AND EXTENTS
  - HEADER/BEAM BELOW FRAMING - TYP

- FOOTNOTES**
- ALIGN w/ STRAP(S) ABOVE
  - POST ABOVE TO BEAR DIRECTLY ON FOUNDATION w/ (2) LAYERS OF BUILDING PAPER AND (2) A35 TO BOTTOM PLATE
  - PROVIDE RFPF BLOCKING BETWEEN JOISTS w/ IUS HANGER EACH END
  - DROPPED FLOOR FRAMING AT SHOWER CONSISTS OF 3/4" T&G APA RATED SHEATHING (SPAN RATING 48/24) OVER 2x6's AT 16"oc, UNO. PROVIDE LUS HANGERS EACH END
  - PROVIDE DOUBLE JOISTS BELOW KITCHEN ISLAND/WINE STORAGE
  - PT 2x4 x 10'-0" LAID FLAT ACROSS UNDERSIDE OF JOIST w/ (2) 10d EACH JOIST
  - DTTIZ AT 48"oc TO DECK FRAMING

**MAIN FLOOR FRAMING PLAN**  
MAIN FLOOR WALLS SHOWN DASHED

**FLUSH BEAM SCHEDULE**

MARK	SIZE	BRG STUDS	HANGER
B1	LVL 1-3/4 x 11-7/8	2	HUS1.81/10
B2	GL 3-1/2 x 11-7/8 OR LVL 3-1/2 x 11-7/8	2	HHUS410
B3	GL 5-1/2 x 11-7/8 OR LVL 5-1/4 x 11-7/8	3	HGUS5.50/10
B4	LVL 7 x 11-7/8	4	HGUS7.25/10
B5	LVL 3-1/2 x 9-1/2	2	HHUS410

- ALL GLULAM BEAMS ARE 24F-V4 - UNO
- PROVIDE HUC410 WHERE REQUIRED - UNO
- PROVIDE BA SERIES HANGER (TOP FLANGE) WHERE REQUIRED AT STEM WALLS

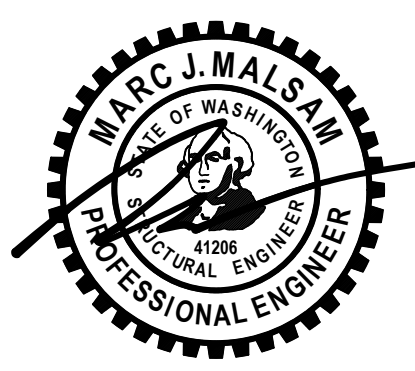

PROJECT NO 0444.2023.09.01  
PROJECT MANAGER WAC  
DRAWN JAS  
ENGINEER GARRETT OSWALD  
206.902.7287  
GARRETTO@MALSAM-TSANG.COM

REV	DESCRIPTION	DATE
	PERMIT SET	7.12.23
	PERMIT CORRECTIONS	12.01.23
	PLAN REVISIONS	2.09.24

ARCH MN CUSTOM HOMES  
425.394.3848

**MAIN FLOOR FRAMING AND FOUNDATION PLAN**

**S2.1B**  
SCALE - 1/4" = 1'-0"



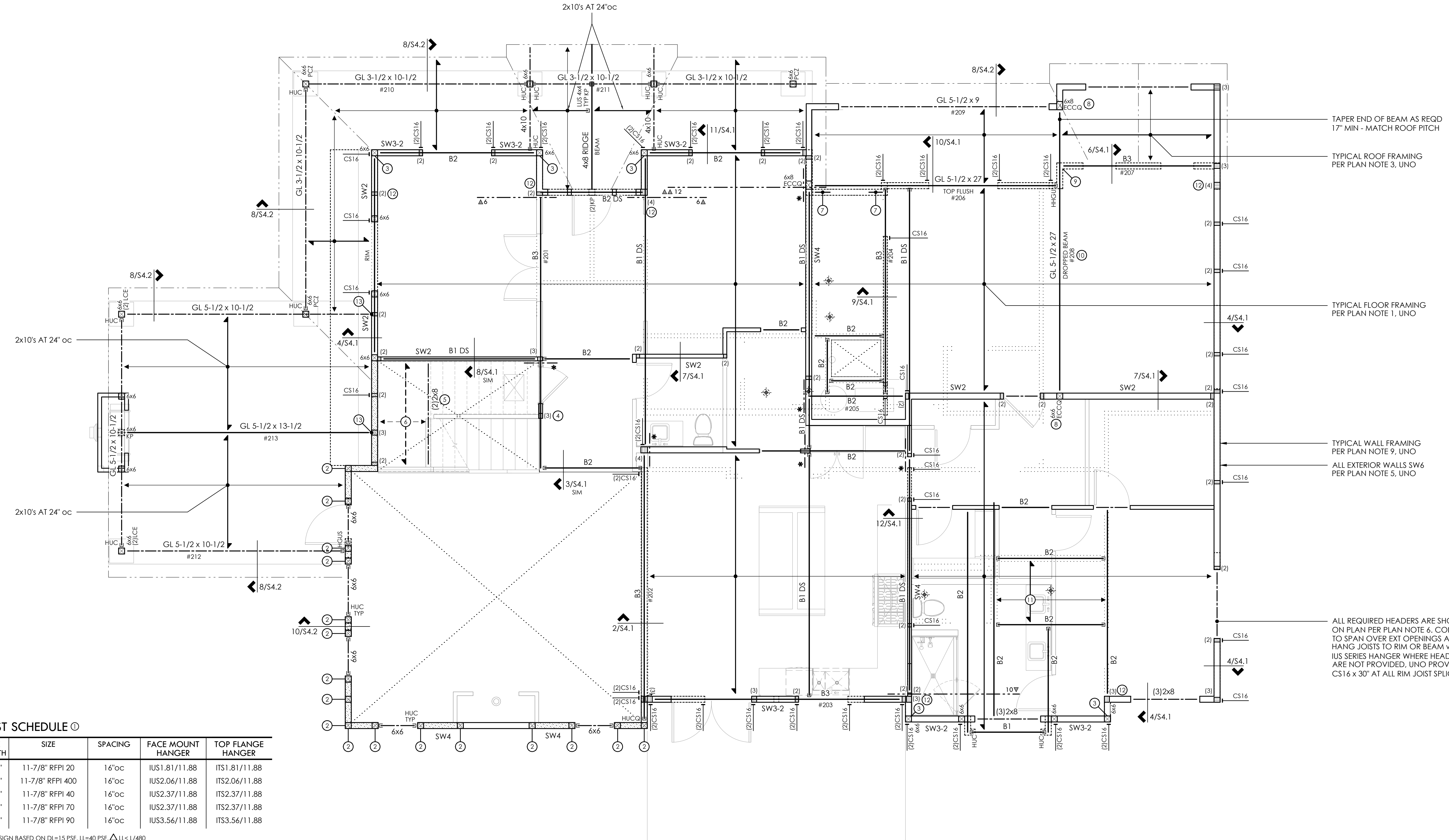

TAPER END OF BEAM AS REQD  
17" MIN - MATCH ROOF PITCH

TYPICAL ROOF FRAMING  
PER PLAN NOTE 3, UNO

TYPICAL FLOOR FRAMING  
PER PLAN NOTE 1, UNO

TYPICAL WALL FRAMING  
PER PLAN NOTE 9, UNO

ALL EXTERIOR WALLS SW6  
PER PLAN NOTE 5, UNO

ALL REQUIRED HEADERS ARE SHOWN  
ON PLAN PER PLAN NOTE 6. CONT RIM  
TO SPAN OVER EXT OPENINGS AND  
HANG JOISTS TO RIM OR BEAM w/  
IUS SERIES HANGER WHERE HEADERS  
ARE NOT PROVIDED, UNO PROVIDE  
CS16 x 30" AT ALL RIM JOIST SPLICES

**JOIST SCHEDULE**

MAX LENGTH	SIZE	SPACING	FACE MOUNT HANGER	TOP FLANGE HANGER
16'-6"	11-7/8" RFP1 20	16"oc	IUS1.81/11.88	ITS1.81/11.88
17'-3"	11-7/8" RFP1 400	16"oc	IUS2.06/11.88	ITS2.06/11.88
18'-0"	11-7/8" RFP1 40	16"oc	IUS2.37/11.88	ITS2.37/11.88
19'-3"	11-7/8" RFP1 70	16"oc	IUS2.37/11.88	ITS2.37/11.88
21'-3"	11-7/8" RFP1 90	16"oc	IUS3.56/11.88	ITS3.56/11.88

DESIGN BASED ON DL=15 PSF, LL=40 PSF, ΔLL< L/480

- PLAN NOTES**
- TYPICAL FLOOR FRAMING CONSISTS OF 3/4" T&G APA RATED SHEATHING (SPAN RATING 48/24) OVER RFP1'S PER JOIST SCHEDULE, UNO. PROVIDE DBL JOISTS UNDER ALL PARALLEL PARTITIONS THAT EXTEND OVER MORE THAN HALF THE JOIST LENGTH.
  - GLUE AND NAIL FLOOR SHEATHING w/ 8d AT 6"oc AT FRAMED PANEL EDGES AND OVER SHEARWALLS AND AT 12"oc IN FIELD, UNO.
  - TYPICAL ROOF FRAMING CONSISTS OF 7/16" or 1/2" APA RATED SHEATHING (SPAN RATING 32/16) OVER PRE-MANUFACTURED TRUSSES AT 24"oc, UNO. PROVIDE H2.5A CLIPS EACH END OF ALL TRUSSES, AND H2.5A EACH SIDE OF ALL MULTIPLE TRUSSES, UNO. REFER TO ARCH DRAWINGS FOR TRUSS PROFILE.
  - NAIL ROOF SHEATHING w/ 8d AT 6"oc AT FRAMED PANEL EDGES AND OVER SHEARWALLS, AND AT 12"oc IN THE FIELD, UNO.
  - "SW\_" INDICATES SHEARWALL BELOW FRAMING SHOWN. REFER TO SHEARWALL SCHEDULE ON 4/S4.0 FOR ADDITIONAL INFORMATION. ALL EXTERIOR WALLS ARE SW6, UNO.
  - ALL REQUIRED HEADERS ARE SHOWN ON PLAN AND SHALL BE (2)2x8, UNO. REFER TO DETAIL 8/S4.0 FOR ADDITIONAL REQUIREMENTS.
  - PROVIDE (2)BEARING (TRIMMER) STUDS AT EACH END OF ALL HEADERS, BEAMS, AND GIRDER TRUSSES 6'-0" IN LENGTH AND OVER, UNO.
  - WHERE POSTS OCCUR, PROVIDE SOLID VERTICAL GRAIN BLOCKING THRU FLOOR TO MATCHING SUPPORTS BELOW, UNO.
  - TYPICAL WALL FRAMING CONSISTS OF 2x6'S AT 16"oc AT EXTERIOR WALLS AND 2x4'S OR 2x6'S AT 16"oc AT INTERIOR WALLS PER ARCH DRAWINGS, UNO.
  - REFER TO SHEET S4.0 FOR TYPICAL WOOD FRAMING DETAILS.
  - REFER TO GENERAL STRUCTURAL NOTES SHEET S1.0 FOR ADDITIONAL REQUIREMENTS.
  - DO NOT SCALE DRAWINGS. REFER TO ARCH DRAWINGS FOR ALL DIMENSIONS.

- LEGEND**
- STRUCTURAL WALL BELOW
  - STRUCTURAL WALL ABOVE
  - BALLOON FRAME WALL FROM FOUNDATION TO ROOF w/ LVL 1-3/4 x 5-1/2 STUDS AT 16"oc
  - SPAN AND EXTENTS
  - HEADER/BEAM BELOW FRAMING - TYP
  - DIRECTION OF SLOPE
  - NUMBER OF BUILT UP STUDS
  - PLUMBING PENETRATION ABOVE
  - KING POST
  - (2)HORIZ CS16 x X'-0" OVER FLOOR SHEATHING - LAP RIM/BEAM 1'-6" AND NAIL REMAINING LENGTH TO SNUG FIT FLAT 2x6 BLOCKING BETWEEN JOISTS
  - HORIZ CS16 x X'-0" OVER FLOOR SHEATHING - LAP RIM/BEAM 1'-6" AND NAIL REMAINING LENGTH TO SNUG FIT FLAT 2x6 BLOCKING BETWEEN JOISTS

- FOOTNOTES**
- ALIGN w/ STRAP(S) BELOW
  - POST CONTINUOUS FROM FOUNDATION TO ROOF w/ (2)HGA10 TOP AND BOTTOM
  - SHEARWALL SHEATHING CONTINUOUS THRU WALL INTERSECTION
  - PROVIDE (2)A34 TOP AND BOTTOM OF POST
  - POCKET BEAM INTO WALL w/ (2)BEARING STUDS AND (1)FULL HEIGHT STUD EACH SIDE
  - STAIR LANDING CONSISTS OF 2x8'S AT 16"oc w/LUS HANGER 2x8 LEDGER w/(2)0.22Øx4-1/2" SDWS TIMBER SCREWS AT 16"oc INTO EACH STUD
  - PROVIDE RFP1 BLOCKING BELOW WALL WITH IUS HANGER EACH END
  - POST TO BEAR DIRECTLY ON FOUNDATION w/ (2)LAYERS OF BUILDING PAPER AND (2)A35 TO BOTTOM PLATE
  - BEAM TO BEAR DIRECTLY ON DROPPED BEAM w/ A35 EA SIDE OF BEAM
  - TOP OF BEAM TO ALIGN w/ BOT OF FLOOR JOISTS
  - DROPPED FLOOR FRAMING AT SHOWER CONSISTS OF 3/4" T&G APA RATED SHEATHING (SPAN RATING 48/24) OVER 2x10'S AT 16"oc, UNO. PROVIDE LUS HANGERS EACH END
  - ALIGN w/ POST ABOVE
  - POCKET BEAM INTO WALL w/ (3) BEARING STUDS AND (1) FULL HEIGHT STUD EACH SIDE

**UPPER FLOOR FRAMING PLAN**

UPPER FLOOR WALLS SHOWN DASHED  
MAIN FLOOR WALLS SHOWN SOLID

**FLUSH BEAM SCHEDULE**

MARK	SIZE	BRG STUDS	HANGER
B1	LVL 1-3/4 x 11-7/8	2	HUS1.81/10
B2	GL 3-1/2 x 11-7/8 OR LVL 3-1/2 x 11-7/8	2	HHUS410 HHUS410
B3	GL 5-1/2 x 11-7/8 OR LVL 5-1/4 x 11-7/8	3	HGUS5.50/10 HGUS5.50/10
B4	LVL 7 x 11-7/8	4	HGUS7.25/10

ALL GLULAM BEAMS ARE 24F-V4 - UNO  
PROVIDE HUC40 WHERE REQUIRED - UNO

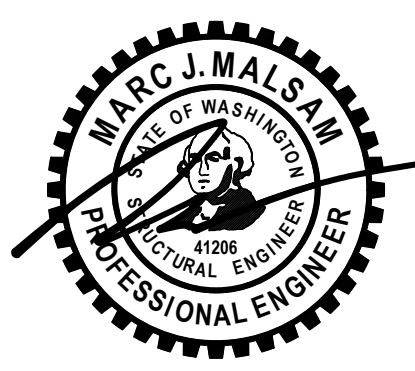

PROJECT NO 0444.2023.09.01  
PROJECT MANAGER WAC  
DRAWN JAS  
ENGINEER GARRETT OSWALD  
206.902.7287  
GARRETTO@MALSAM-TSANG.COM

REV	DESCRIPTION	DATE
	PERMIT SET	7.12.23
	PERMIT CORRECTIONS	12.01.23
	PLAN REVISIONS	2.09.24

ARCH MN CUSTOM HOMES  
425.394.3848

**UPPER FLOOR FRAMING PLAN**

**S2.2**  
SCALE - 1/4" = 1'-0"



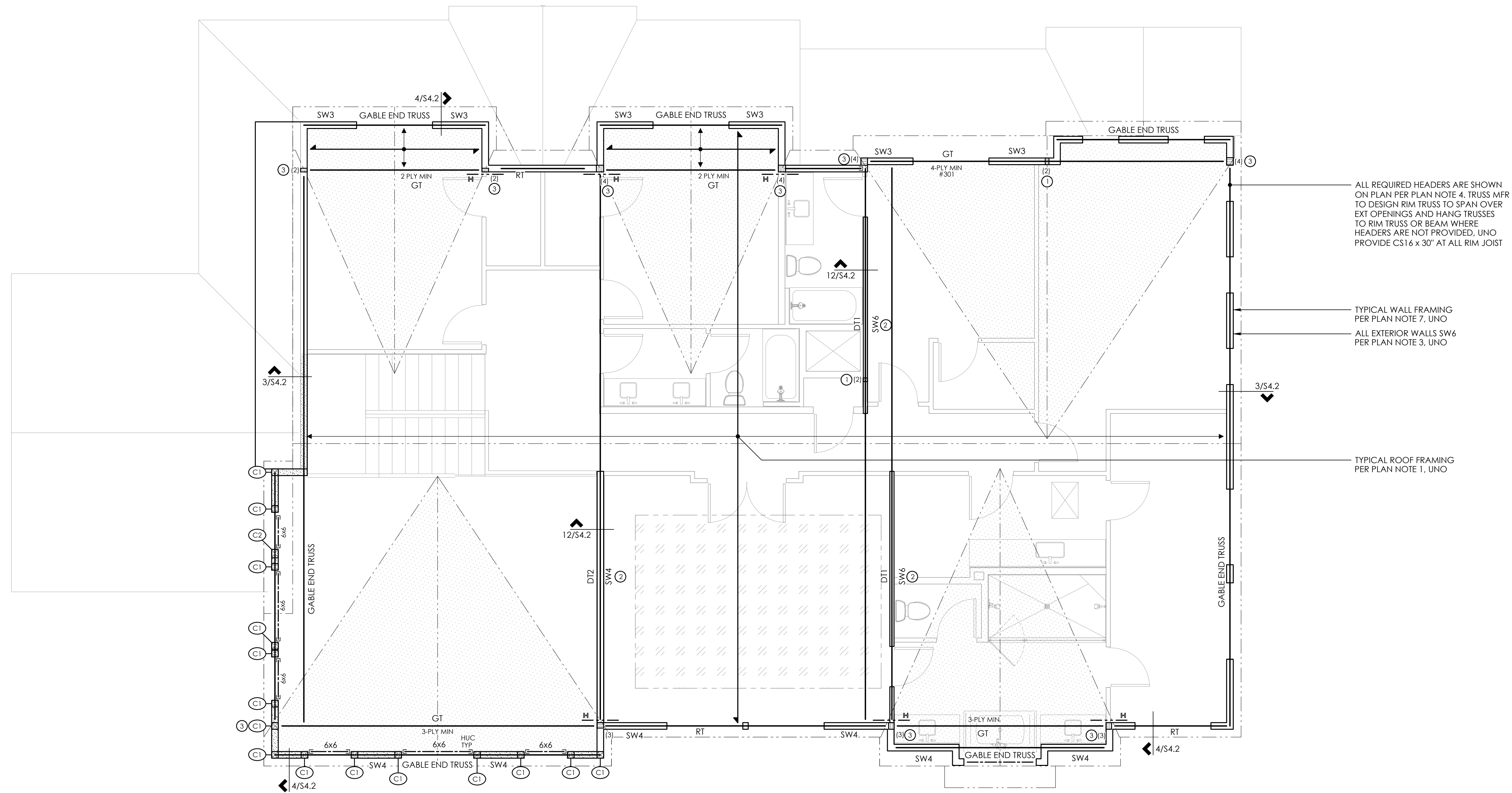

**PLAN NOTES**

- TYPICAL ROOF FRAMING CONSISTS OF 7/16" or 1/2" APA RATED SHEATHING (SPAN RATING 32/16) OVER PRE-MANUFACTURED TRUSSES AT 24"oc. UNO. PROVIDE H2.5A CLIPS EACH END OF ALL TRUSSES, AND H2.5A EACH SIDE OF ALL MULTIPLE TRUSSES. UNO. REFER TO ARCH DRAWINGS FOR TRUSS PROFILE.
- NAIL ROOF SHEATHING w/ 8d AT 6" oc AT FRAMED PANEL EDGES AND OVER SHEARWALLS, AND AT 12"oc IN FIELD. UNO.
- "SW." INDICATES SHEARWALL BELOW FRAMING SHOWN. REFER TO SHEARWALL SCHEDULE ON 4/S4.0 FOR ADDITIONAL INFORMATION. ALL EXTERIOR WALLS ARE SW6. UNO.
- ALL REQUIRED HEADERS ARE SHOWN ON PLAN AND SHALL BE (2)2x8. UNO. REFER TO DETAIL 8/S4.0 FOR ADDITIONAL REQUIREMENTS.
- PROVIDE (2)BEARING (TRIMMER) STUDS AT EACH END OF ALL HEADERS, BEAMS, AND GIRDER TRUSSES 6'-0" IN LENGTH AND OVER. UNO.
- WHERE POSTS OCCUR, PROVIDE SOLID VERTICAL GRAIN BLOCKING THRU FLOOR TO MATCHING SUPPORTS BELOW. UNO.
- TYPICAL WALL FRAMING CONSISTS OF 2x6's AT 16"oc AT EXTERIOR WALLS AND 2x4's or 2x6's AT 16"oc AT INTERIOR WALLS PER ARCH DRAWINGS. UNO.
- REFER TO SHEET S4.0 FOR TYPICAL WOOD FRAMING DETAILS.
- REFER TO GENERAL STRUCTURAL NOTES SHEET S1.0 FOR ADDITIONAL REQUIREMENTS.
- DO NOT SCALE DRAWINGS. REFER TO ARCH DRAWINGS FOR ALL DIMENSIONS.

**LEGEND**

- STRUCTURAL WALL BELOW
- SPAN AND EXTENTS
- HEADER/BEAM BELOW FRAMING - TYP
- DIRECTION OF SLOPE
- NUMBER OF BUILT UP STUDS
- PV PANELS - 5 PSF MAX ADDITIONAL DEAD LOAD. PROVIDE MISC BLOCKING AS REQD PER PV PANEL MANUFACTURER
- OVERFRAMING - PRE-MFR STEPPED TRUSSES AT 24" oc
- BALLOON FRAME WALL FROM FOUNDATION TO ROOF w/ LVL 1-3/4 x 5-1/2 STUDS AT 16"oc
- HTS30C - BEAM TO TOP PLATE
- GIRDER TRUSS
- RIM TRUSS
- DRAG TRUSS - NAIL THRU SHEATHING w/ 8d AT 4"oc INTO ENTIRE LENGTH OF TRUSS
- LVL 5-1/4 x 5-1/4 CONT FROM FOUNDATION TO ROOF (2)HGA10 TOP AND BOTTOM
- LVL 5-1/4 x 7 CONT FROM FOUNDATION TO ROOF (2) HGA10 TOP AND BOTTOM

**FOOTNOTES**

- ① ALIGN w/ STRAP(S) BELOW
- ② NOT A BEARING WALL FOR TRUSSES
- ③ GIRDER TRUSS BEARING POINT

**ROOF FRAMING PLAN**

UPPER FLOOR WALLS SHOWN SOLID



**DRAG TRUSS SCHEDULE**

MARK	LOAD TRANSFER
DT1	2.5 KIPS
DT2	4.5 KIPS

- ① TRUSS MFR TO DESIGN TRUSS TO TRANSFER LISTED LOAD FROM TOP TO BOT CHORD
- ② NAIL THRU SHEATHING w/ 8d AT 4"oc INTO ENTIRE LENGTH OF MEMBER

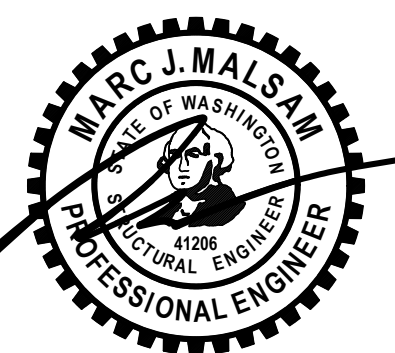

PROJECT NO 0444.2023.09.01  
PROJECT MANAGER WAC  
DRAWN GARRETT OSWALD JAS  
ENGINEER GARRETT OSWALD 206.902.7287  
GARRETTO@MALSAM-TSANG.COM

REV	DESCRIPTION	DATE
PERMIT SET		7.12.23
PERMIT CORRECTIONS		12.01.23
PLAN REVISIONS		2.09.24

ARCH MN CUSTOM HOMES  
425.394.3848

**ROOF FRAMING PLAN**

**S2.3**  
SCALE - 1/4" = 1'-0"



**ABBREVIATIONS**

±	PLUS OR MINUS	GL	GLUE LAMINATED	OSB	ORIENTED STRAND BOARD
∅	DIAMETER	GR	TIMBER	PLF	POUNDS PER LINEAR FOOT
AB	ANCHOR BOLT	GT	GRADE GIRDER TRUSS	PLY	PLYWOOD
ADDL	ADDITIONAL	GWB	GYP SUM WALLBOARD	PREFAB	PREFABRICATED
ALT	ALTERNATE	HD	HOLDOWN	PSF	POUNDS PER SQUARE FOOT
APPROX	APPROXIMATE	HDR	HEADER	PSI	POUNDS PER SQUARE INCH
ARCH	ARCHITECTURAL	HF	HEM FIR	PT	PRESSURE TREATED LUMBER
BLKG	BLOCKING	HGR	HANGER	REINF	REINFORCING
BM	BEAM	HM	HIP MASTER	REQD	REQUIRED
BOE	BOTTOM OF EXCAVATION	HORIZ	HORIZONTAL	SOG	SLAB ON GRADE
BOT	BOTTOM	HT	HEIGHT	SQ	SQUARE
CL	CENTERLINE	IBC	INTERNATIONAL BUILDING CODE	STD	STANDARD
CLR	CLEARANCE	INT	INTERIOR	SW	SHEARWALL
CONT	CONTINUOUS	IRC	INTERNATIONAL RESIDENTIAL CODE	T&G	TONGUE AND GROOVE
DBL	DOUBLE	JST	JOIST	THRD	THREADED
DF	DOUGLAS FIR	K	KIPS (1000 LBS)	TPL	TRIPLE
DP	DEEP, DEPTH	KP	KING POST	TRANSV	TRANSVERSE
DN	DOWN	L	LENGTH	TYP	TYPICAL
DS	DRAG STRUT	LBS	POUNDS	UNO	UNLESS NOTED OTHERWISE
DWGS	DRAWINGS	LSL	LONGITUDINAL LAMINATED LUMBER	VERT	VERTICAL
(E)	EXISTING	LVL	LAMINATED VENEER LUMBER	W	WIDE OR WIDTH
EA	EACH	MAX	MAXIMUM	w/	WITH
EMBED	EMBEDMENT	MB	MACHINE BOLT	w/o	WITHOUT
EQUIV	EQUIVALENT	MFR	MANUFACTURER	WHS	WELDED HEADED STUD
EQ	EQUAL	MIN	MINIMUM	WTS	WELDED THREADED STUD
EW	EACH WAY	MISC	MISCELLANEOUS	WWM	WELDED WIRE MESH
EXP	EXPANSION	NO	NUMBER		
EXT	EXTERIOR	NTS	NOT TO SCALE		
FDN	FOUNDATION	OC	ON CENTER		
FRMG	FRAMING	OPP	OPPOSITE		
FT	FEET				
FTG	FOOTING				
GA	GAUGE				
GALV	GALVANIZED				

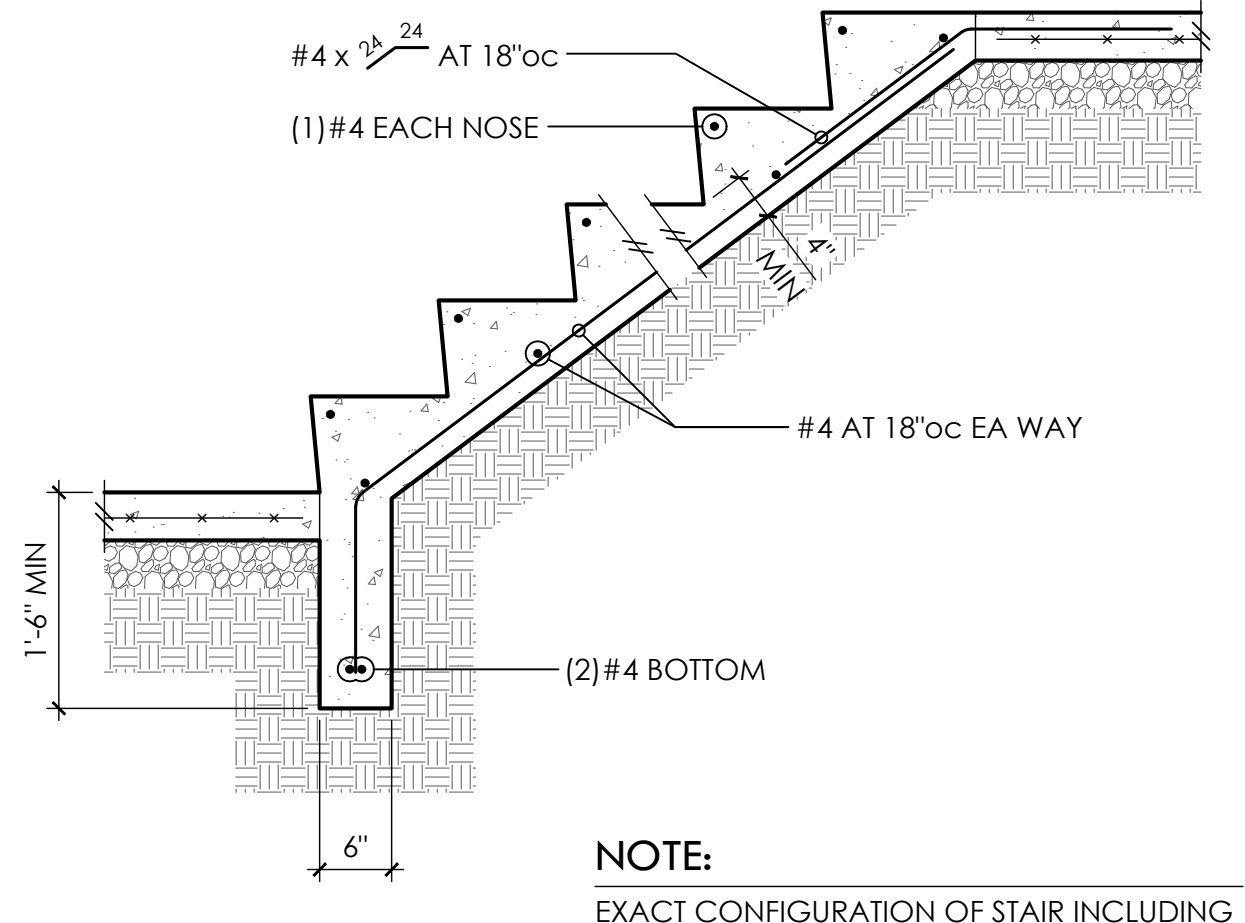

**1** TYPICAL STAIR ON GRADE **2**

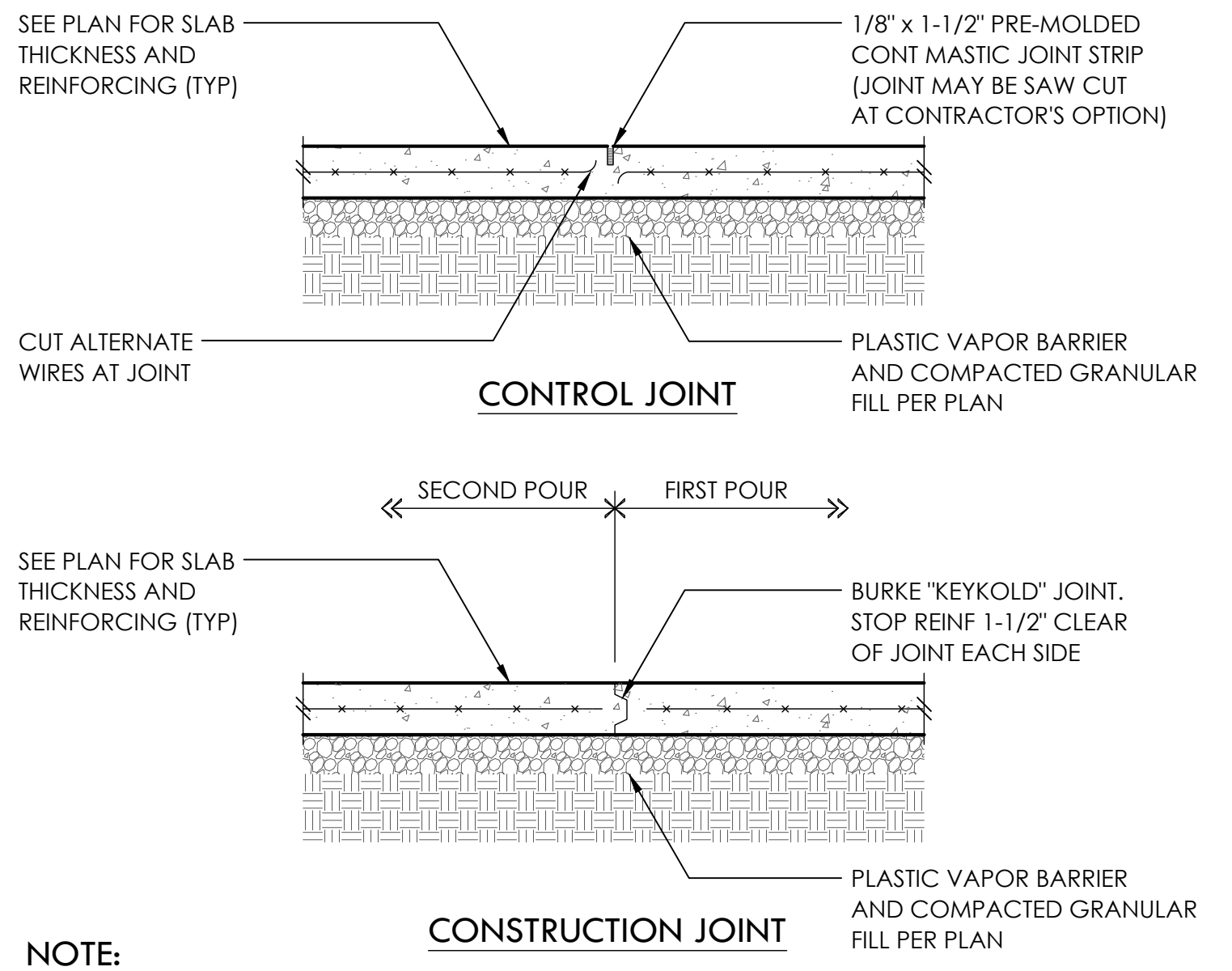

**3** TYPICAL SLAB JOINTS **3**

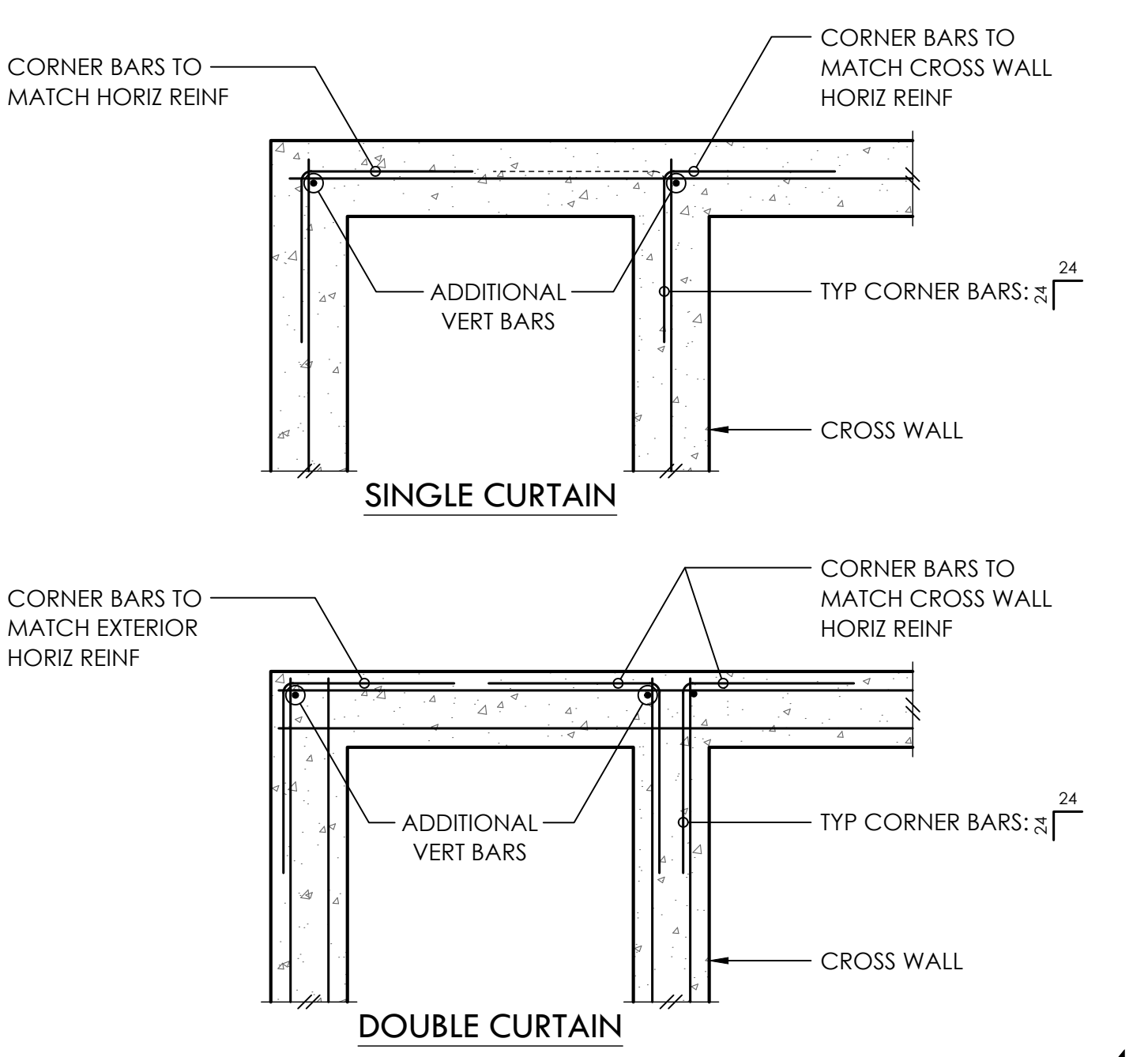

**4** TYP CORNER BARS AT CONCRETE WALLS AND FTGS **4**

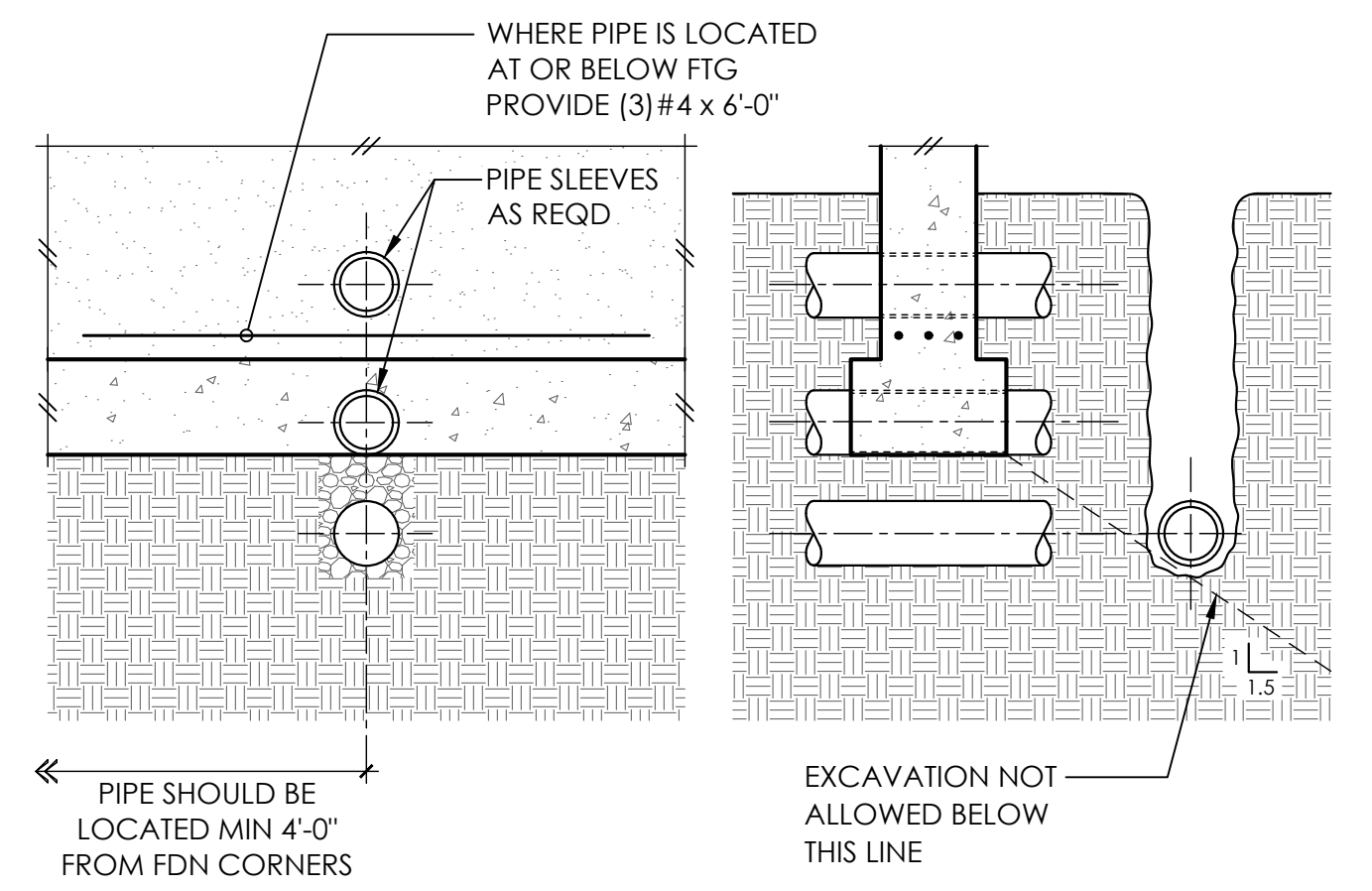

**5** PIPE AND TRENCH LOCATIONS **6**

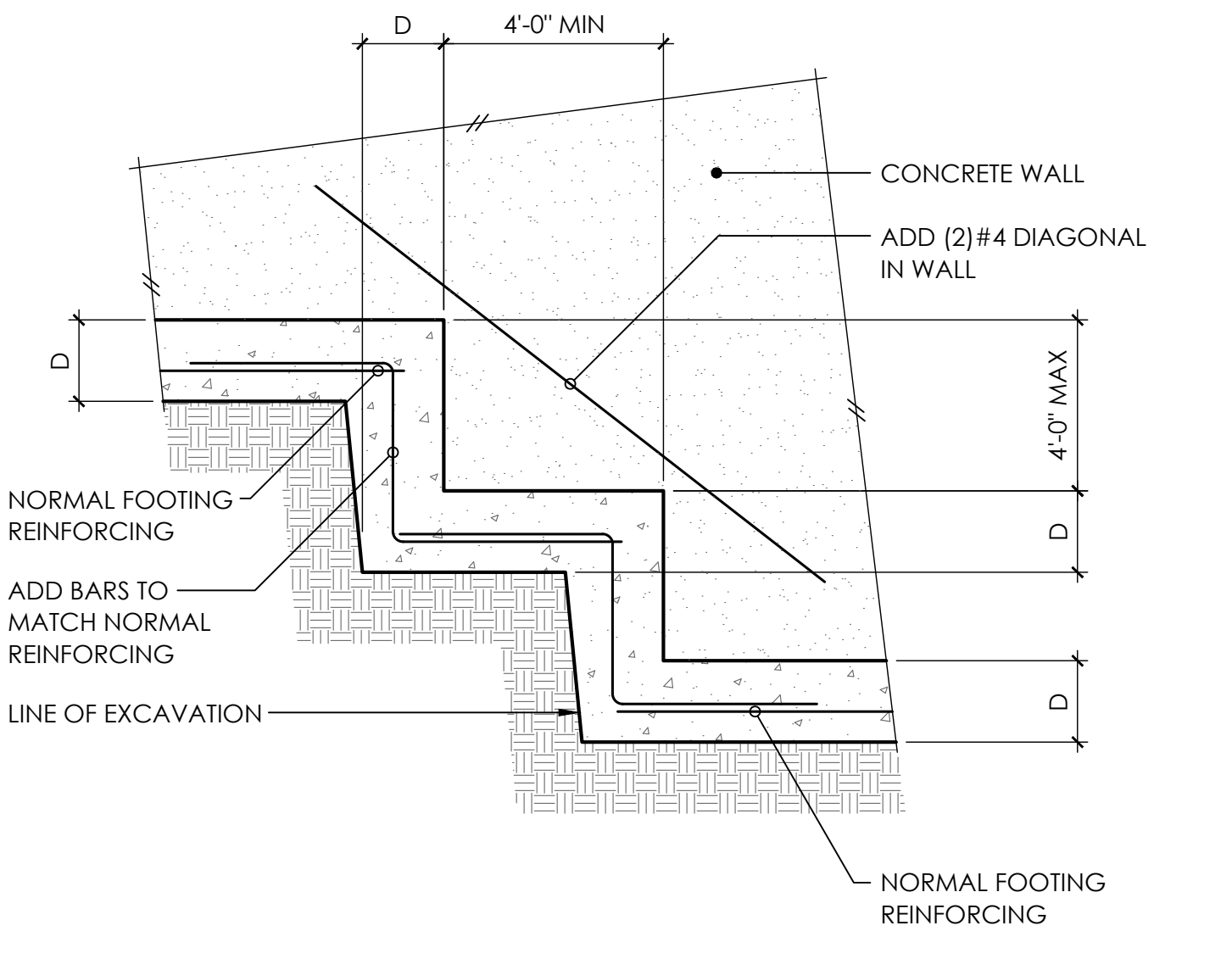

**6** TYPICAL STEPPED FOOTING **8**

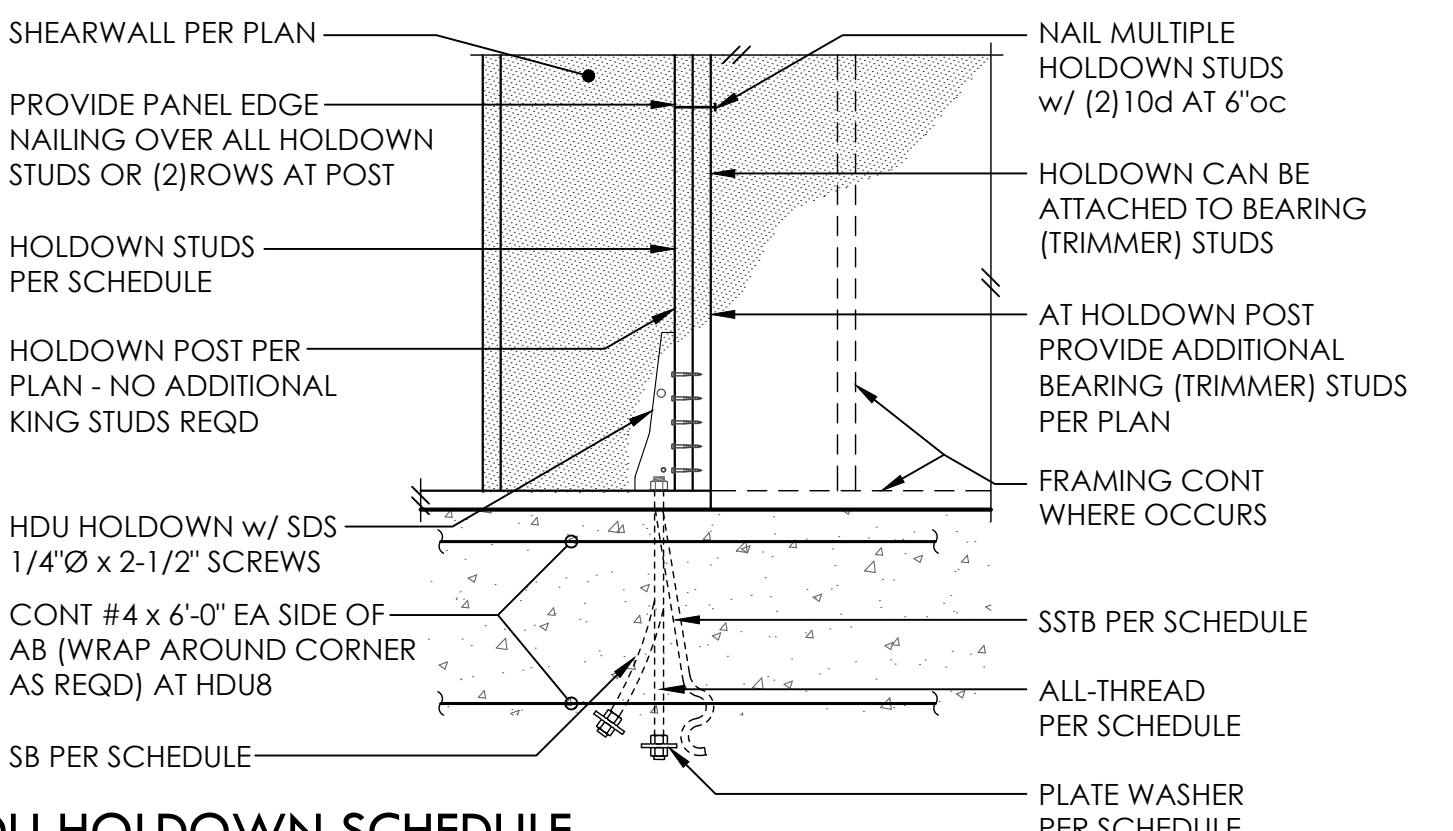

**HDU HOLDOWN SCHEDULE**

PLAN MARK	AT STEMWALL		AT FOOTING Ⓞ			HD POST Ⓞ	
	AB	EMBED	ALL-THREAD	WASHER	EMBED	4x WALL	6x WALL
HDU2	5/8"Ø - SSTB 16(L)	12-5/8"	5/8"Ø	1-3/4"SQ x 1/2	9"	(2)2x4	(2)2x6
HDU4	5/8"Ø - SB5/8 x 24	18"	5/8"Ø	1-3/4"SQ x 1/2	9"	(2)2x4	(2)2x6
HDU5	5/8"Ø - SB5/8 x 24	18"	5/8"Ø	1-3/4"SQ x 1/2	9"	(2)2x4	(2)2x6
HDU8	7/8"Ø - SB7/8 x 24	18"	7/8"Ø	2-1/2"SQ x 1/2	12"	4x6	6x6

- Ⓞ ALL HOLDOWN ANCHOR BOLTS THAT NEED TO BE EMBEDDED INTO FOOTING ARE SPECIFICALLY SHOWN ON PLAN
- Ⓞ A307 ALL-THRD w/ PLATE WASHER PER SCHEDULE AND DOUBLE NUT BOT OR EQUIVALENT SIMPSON PAB
- Ⓞ MINIMUM SIZE OF POST UNO ON FRAMING PLANS

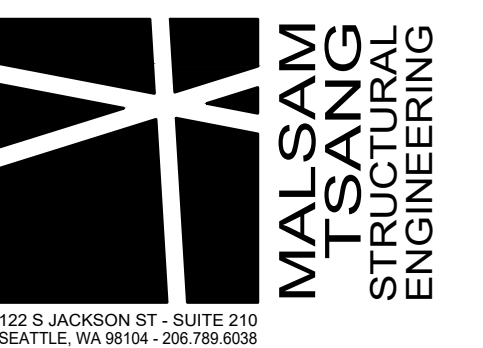

**PLAN MN472**  
7119 80TH AVE SE  
MERCER ISLAND, WA 98040

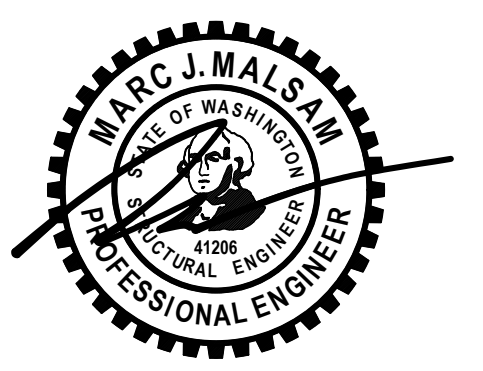

PROJECT NO 0444.2023.09.01  
PROJECT MANAGER WAC  
DRAWN JAS  
ENGINEER GARRETT OSWALD  
206.902.7287  
GARRETO@MALSAM-TSANG.COM

REV	DESCRIPTION	DATE
	PERMIT SET	7.12.23
△	PERMIT CORRECTIONS	12.01.23
△	PLAN REVISIONS	2.09.24

ARCH MN CUSTOM HOMES 425.394.3848

**TYPICAL CONCRETE DETAILS**

**S3.0**  
SCALE - 3/4" = 1'-0"

Printed by: msh  
 Printed Date: 06/26/2024 - 11:09am



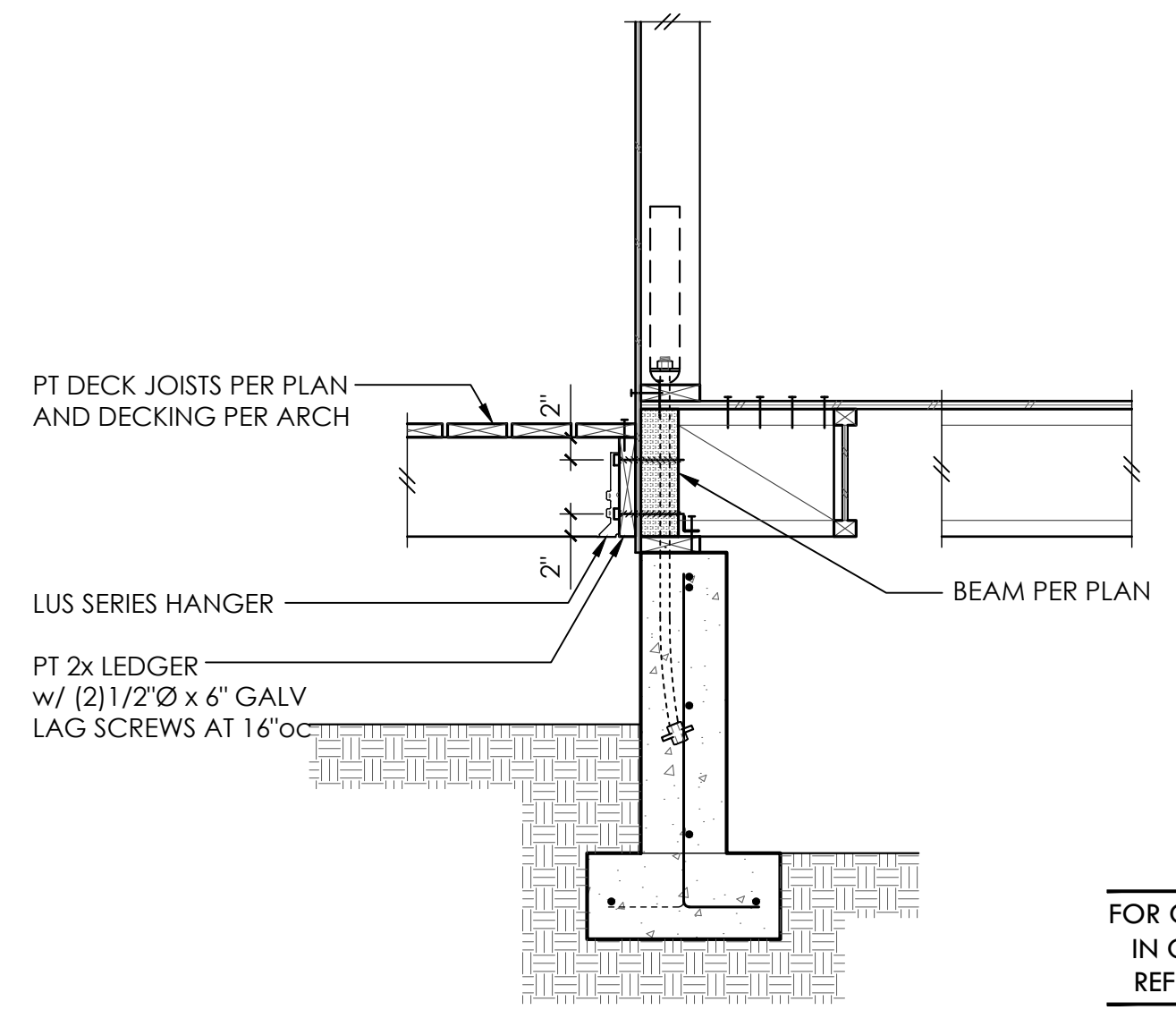

1

FOR CALLOUTS  
IN COMMON  
REFER 4/35.1

2

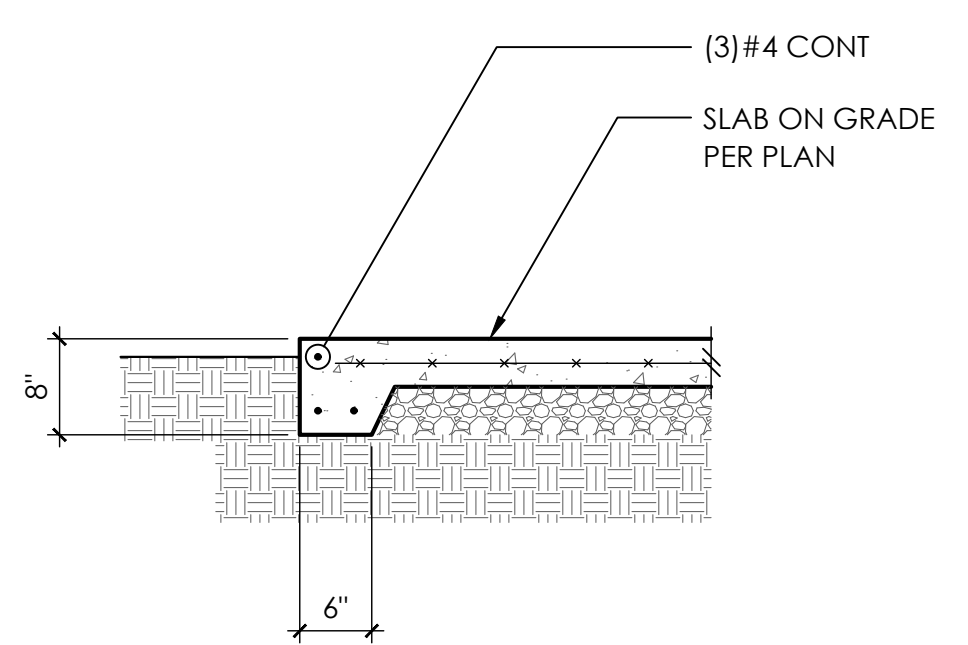

TYPICAL SLAB EDGE

3

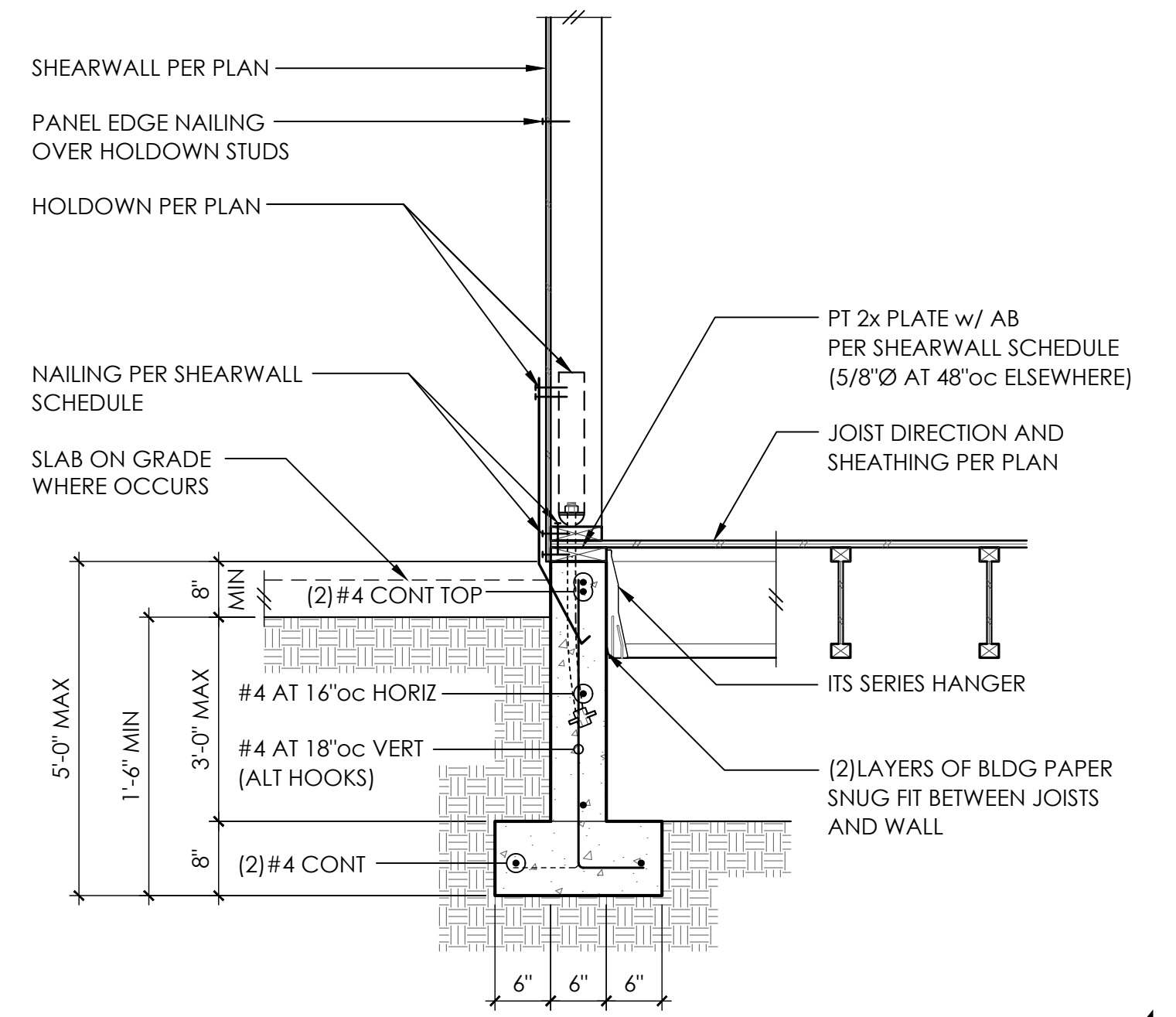

4

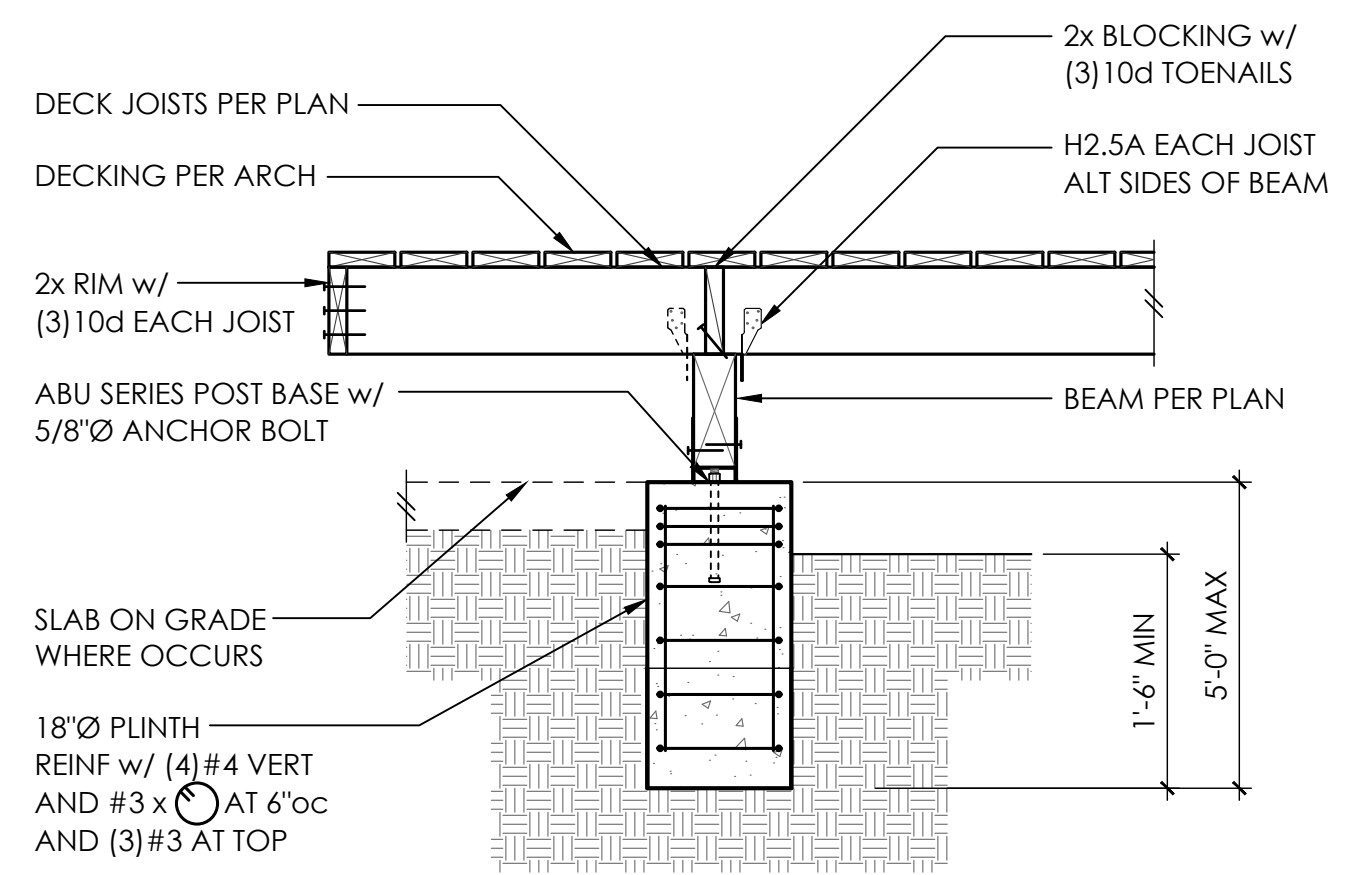

5

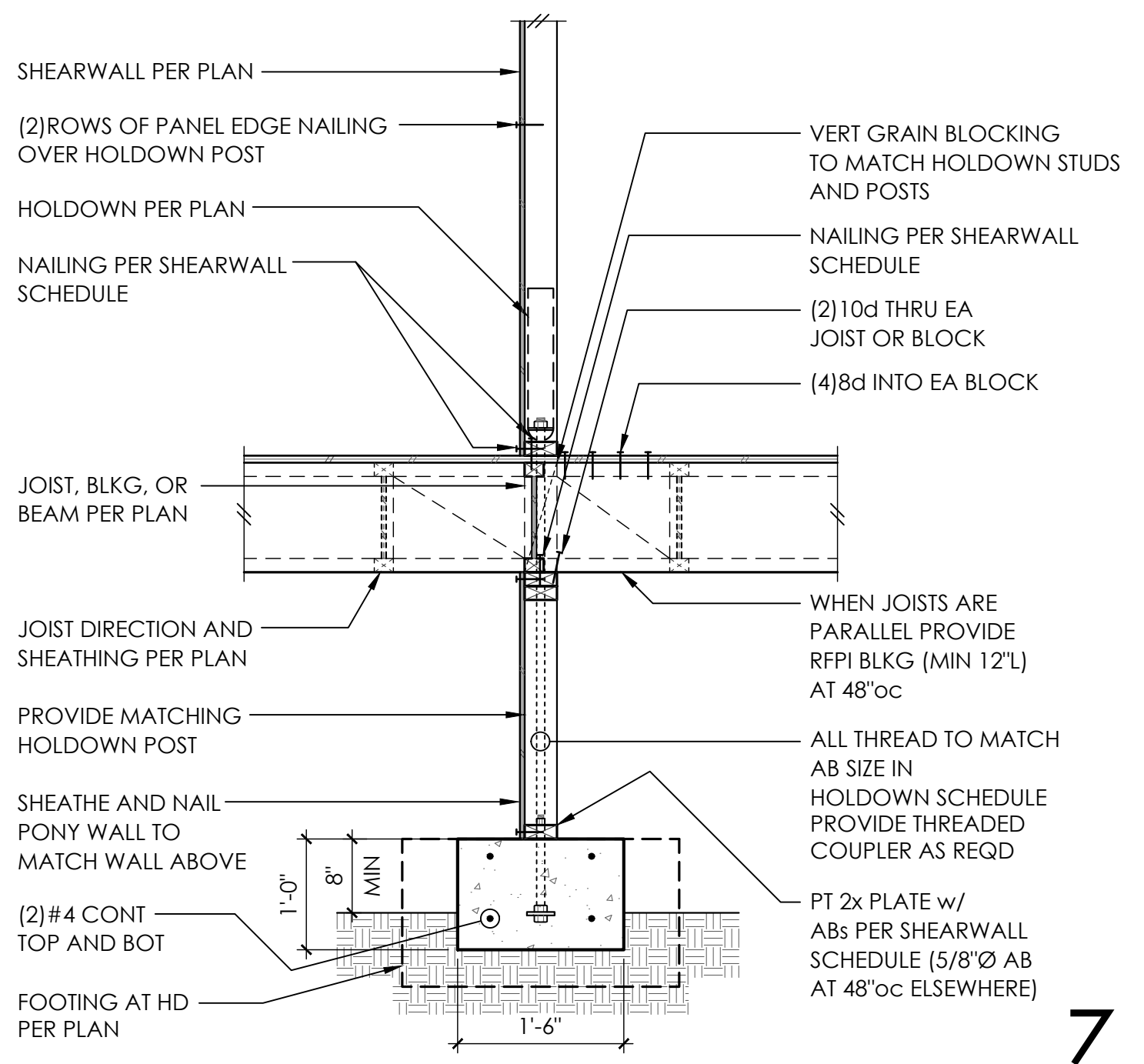

6

7

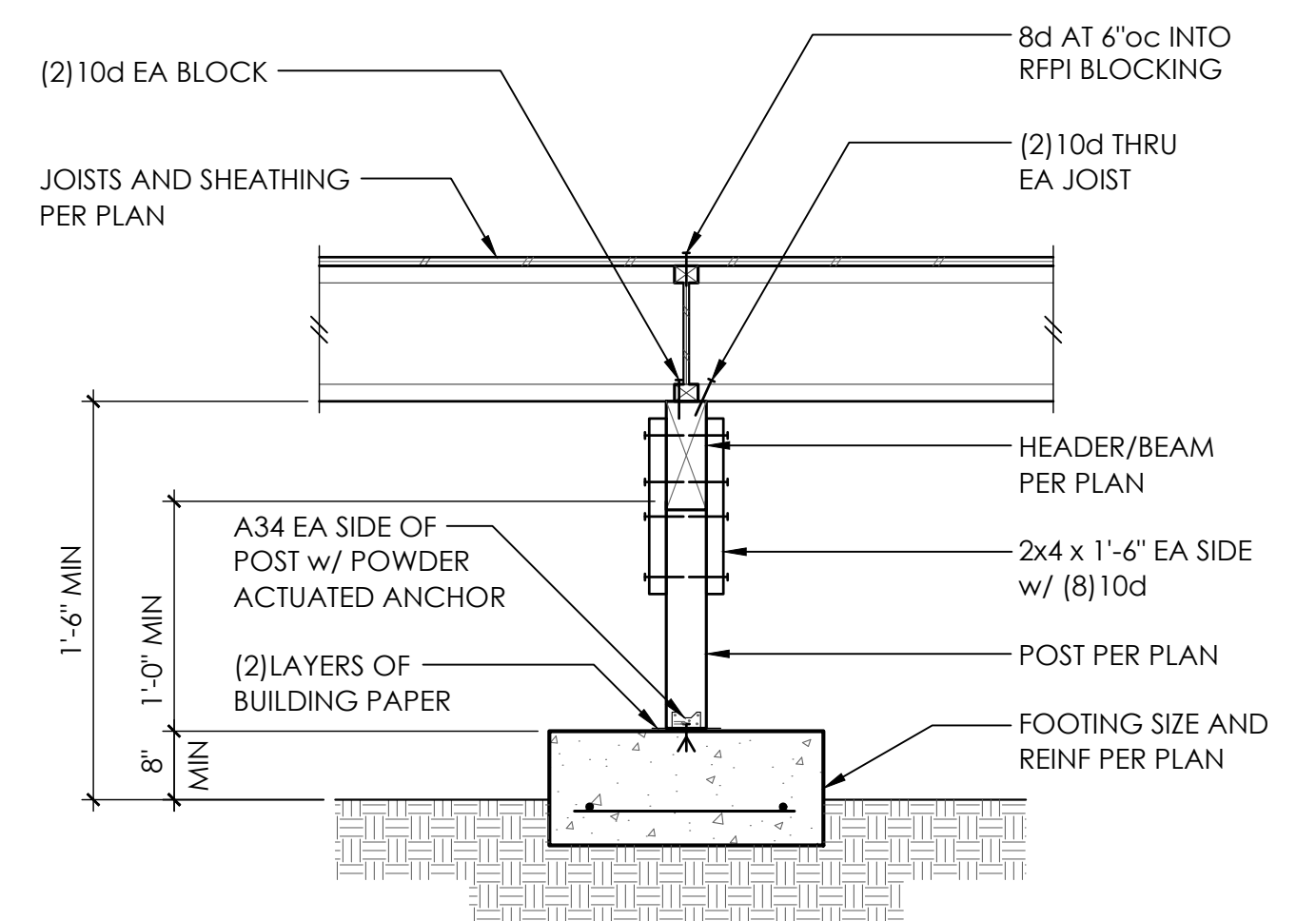

8

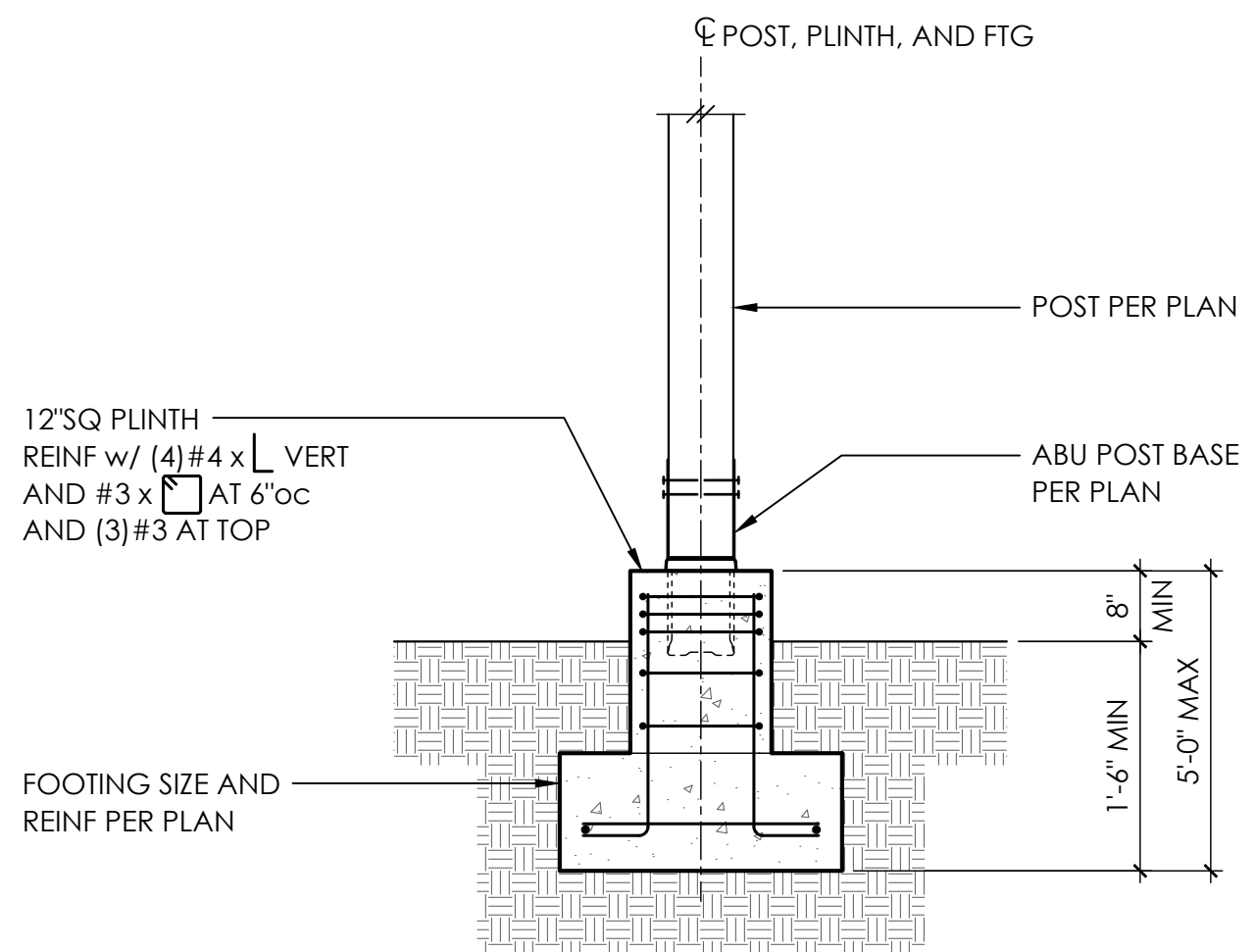

9

10

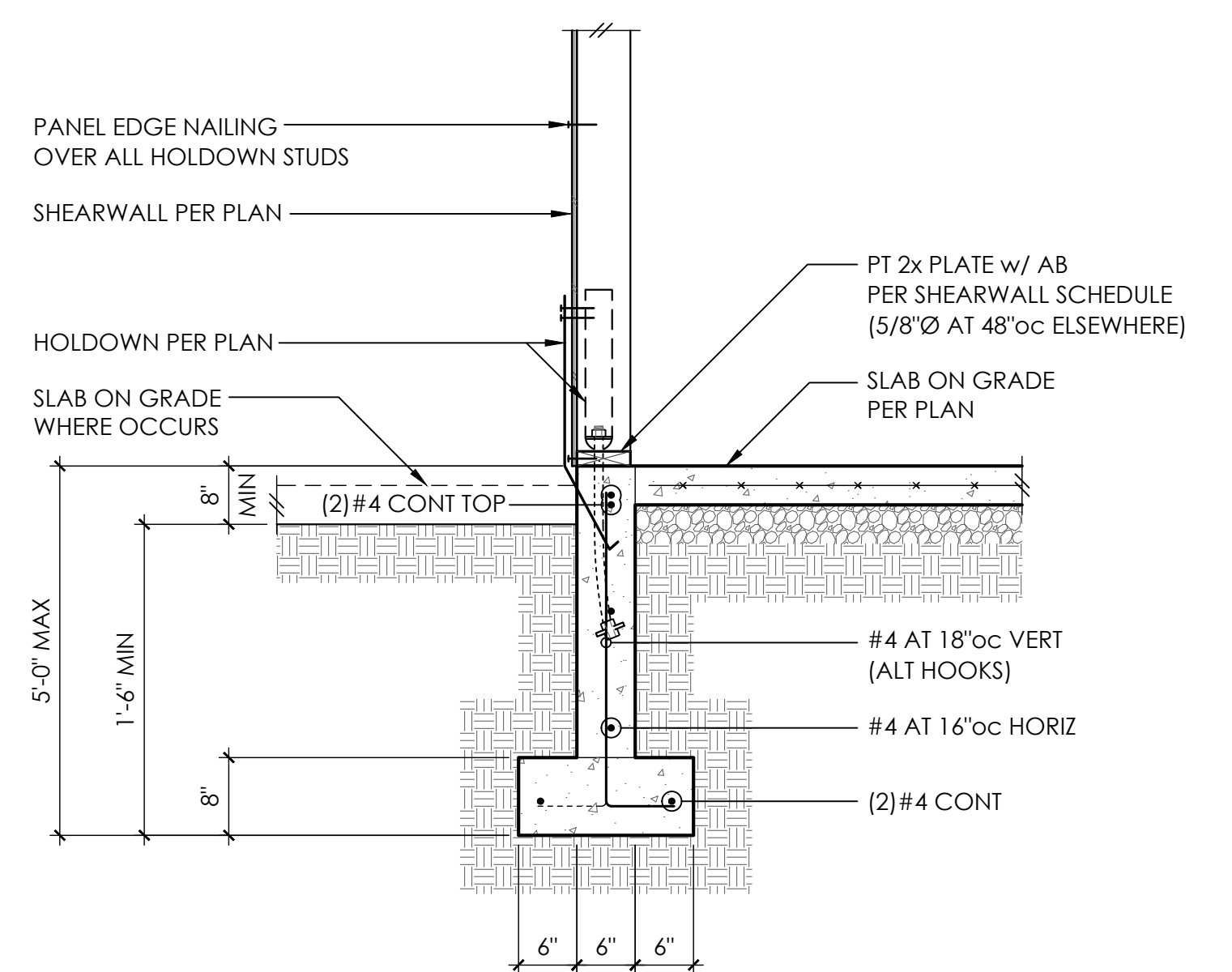

11

12

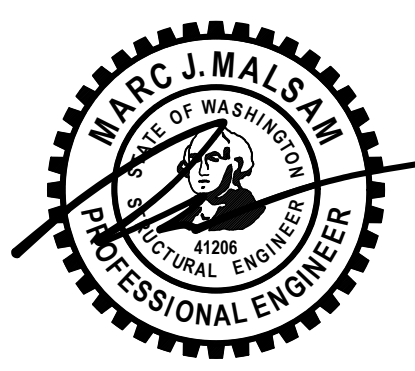

PROJECT NO	0444.2023.09.01	
PROJECT MANAGER	WAC	
DRAWN	JAS	
ENGINEER	GARRETT OSWALD	
	206.902.7287	
	GARRETTO@MALSAM-TSANG.COM	
REV	DESCRIPTION	DATE
	PERMIT SET	7.12.23
△	PERMIT CORRECTIONS	12.01.23
△	PLAN REVISIONS	2.09.24

ARCH MN CUSTOM HOMES  
425.394.3848

CONCRETE DETAILS



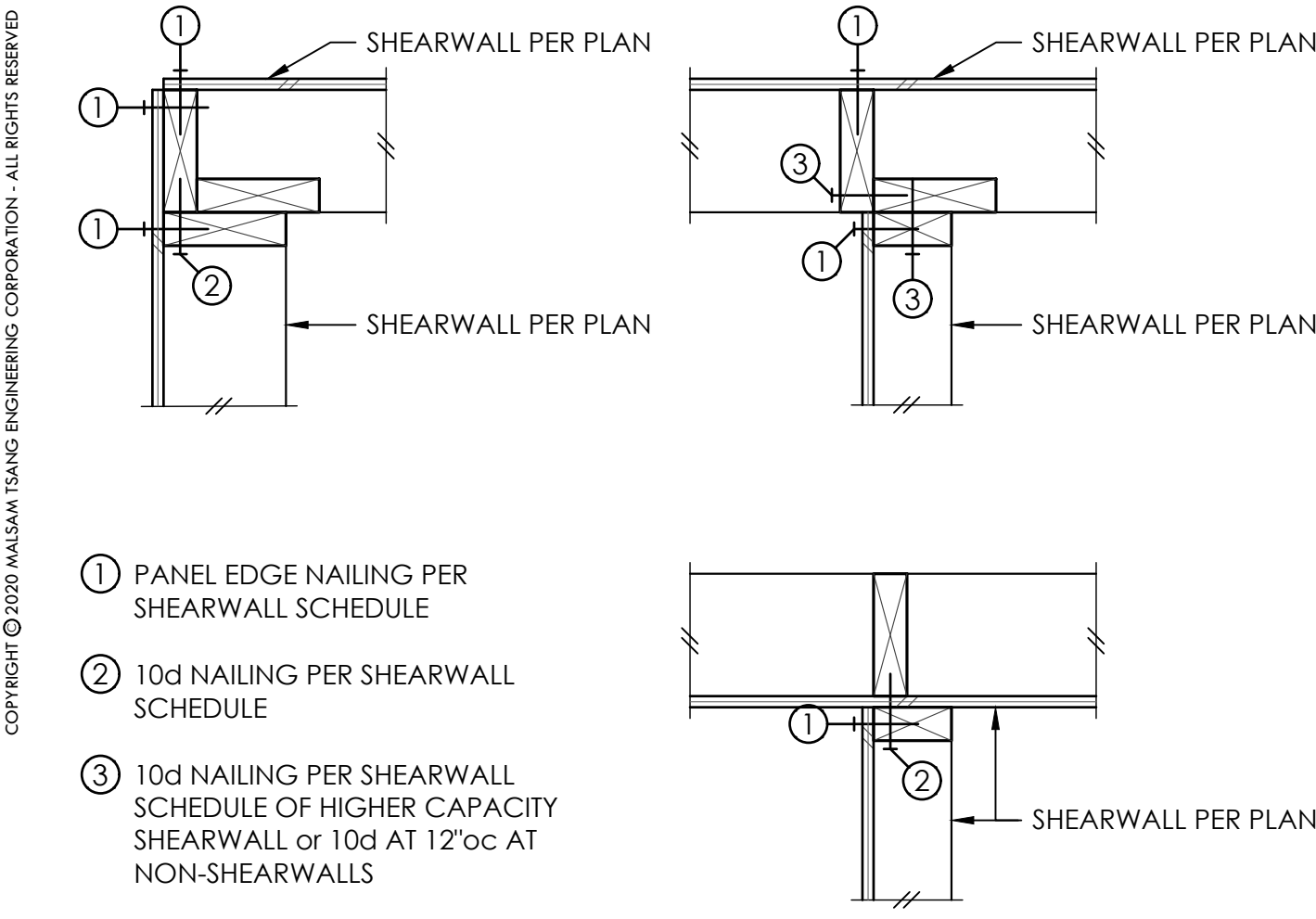

SCALE: 1-1/2" = 1'-0"  
**TYPICAL SHEARWALL INTERSECTIONS** 1

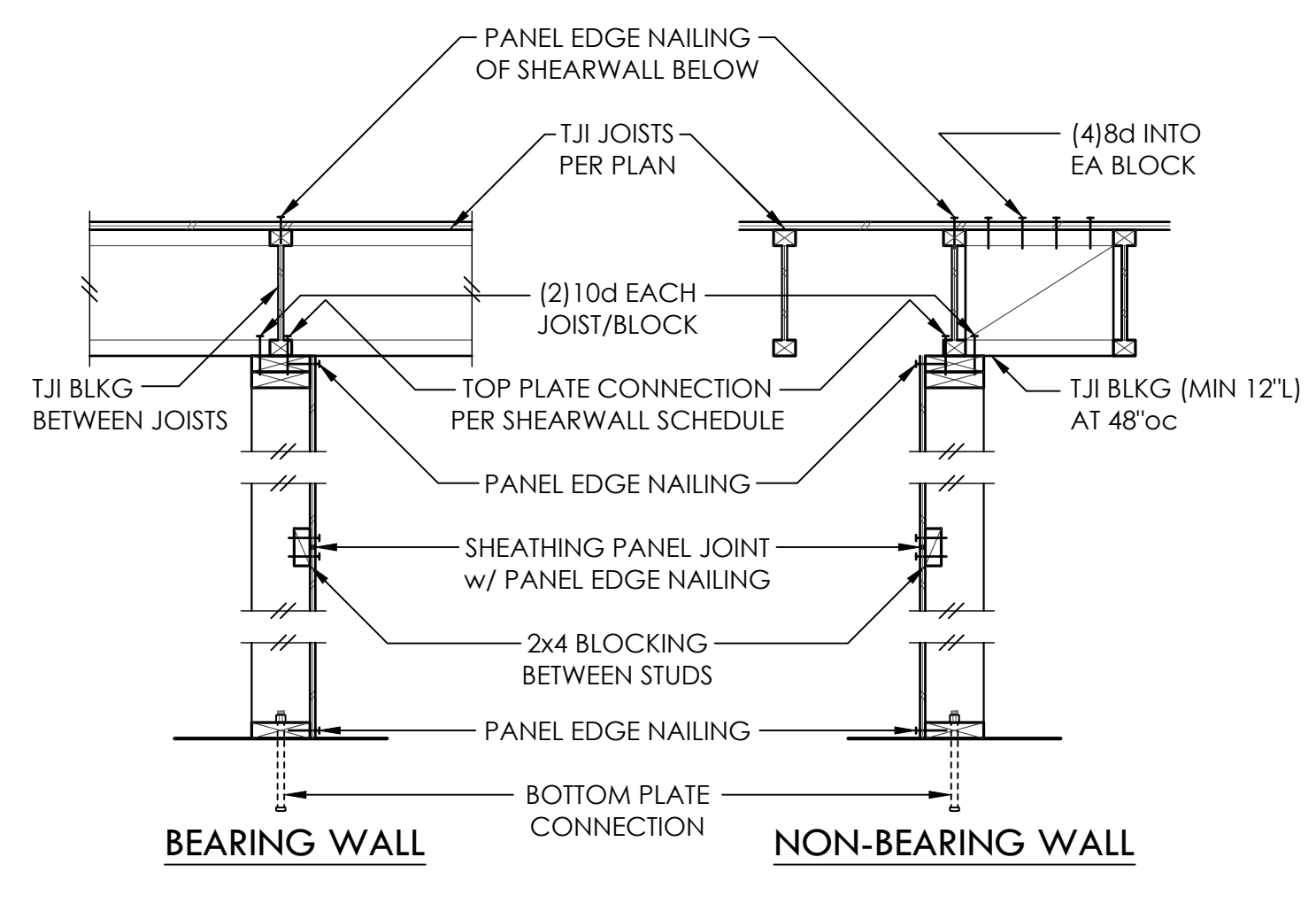

**NOTE:**  
SEE SHEARWALL SCHEDULE FOR ALL NAILING AND CONNECTIONS, UNO

**TYPICAL SHEARWALL CONSTRUCTION** 2

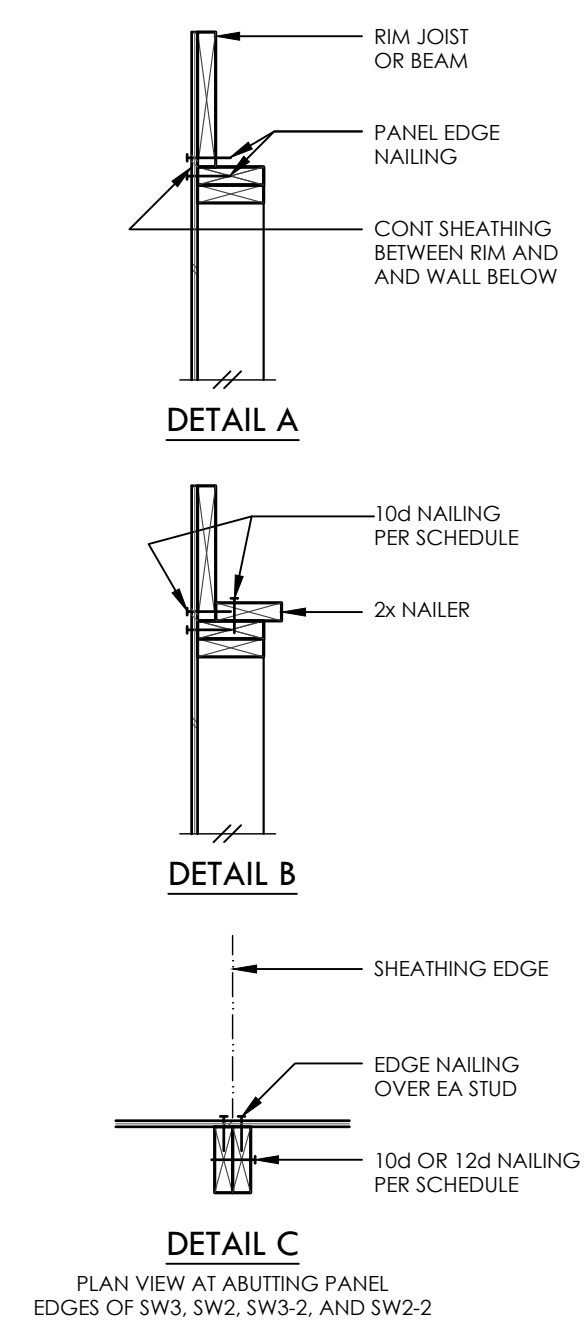

**SHEARWALL SCHEDULE**

MARK	SHEATHING	PANEL EDGE NAILING	TOP PLATE CONNECTION		BASE PLATE CONNECTION	
			TJI	RIM/BEAM	AT WOOD	AT CONCRETE
SW6	1/2" PLY or 7/16" OSB	8d AT 6"oc	10d AT 6"oc	A35 AT 30"oc	12d AT 6"oc	5/8"Ø AB AT 48"oc
SW4	1/2" PLY or 7/16" OSB	8d AT 4"oc	10d AT 4"oc	A35 AT 18"oc	12d AT 4"oc	5/8"Ø AB AT 42"oc
SW3	1/2" PLY or 7/16" OSB	8d AT 3"oc	(2)ROWS 10d AT 6"oc	A35 AT 16"oc	(2)ROWS 12d AT 6"oc	5/8"Ø AB AT 36"oc
SW2	1/2" PLY or 7/16" OSB	8d AT 2"oc	(2)ROWS 10d AT 4"oc	A35 AT 12"oc	(2)ROWS 12d AT 4"oc	5/8"Ø AB AT 24"oc
SW3-2	1/2" PLY or 7/16" OSB EA SIDE	8d AT 3"oc EA SIDE	N/A	A35 AT 8"oc	(2)ROWS 12d AT 3"oc	5/8"Ø AB AT 18"oc
SW2-2	1/2" PLY or 7/16" OSB EA SIDE	8d AT 2"oc EA SIDE	N/A	A35 AT 6"oc	(3)ROWS 12d AT 3"oc	5/8"Ø AB AT 12"oc

- 1 BLOCK PANEL EDGES WITH 2x4 LAID FLAT AND NAIL PANELS TO INTERMEDIATE SUPPORTS WITH 8d AT 12"oc.
- 2 8d NAILS SHALL BE 0.131"Ø x 2-1/2", 10d NAILS SHALL BE 0.131"Ø x 3", AND 12d NAILS SHALL BE 0.131"Ø x 3-1/4".
- 3 EMBED ANCHOR BOLTS AT LEAST 7". ALL BOLTS SHALL HAVE 3" x 3" x 0.229" PLATE WASHERS. THE PLATE WASHER SHALL EXTEND TO WITHIN 1/2" OF THE EDGE OF THE BOTTOM PLATE ON THE SIDE(S) w/ SHEATHING. AT 2x6 SW3-2 AND SW2-2 WALLS, PROVIDE 4-1/2" x 3" x 0.229" PLATE WASHERS CENTERED ON PLATE.
- 4 3x STUDS OR DBL STUDS NAILED TOGETHER w/ 10d OR 12d NAILING IS REQD AT ABUTTING PANEL EDGES OF SW3, SW2, SW3-2, AND SW2-2. REFER TO DETAIL C. WHERE 3x STUDS ARE USED, STAGGER NAILS AT ADJOINING PANEL EDGES. ABUTTING PANEL EDGES SHALL BE OFFSET EACH SIDE OF WALL AT SW3-2 AND SW2-2.
- 5 TWO STUDS MINIMUM OR POST PER PLAN ARE REQUIRED AT EACH END OF ALL SHEARWALLS AND ALL END STUDS SHALL RECEIVE PANEL EDGE NAILING.
- 6 ALL EXTERIOR WALLS SHALL BE SW6, UNLESS NOTED OTHERWISE.
- 7 NAILS SHALL NOT BE SPACED LESS THAN 3/8" FROM EDGES OF SHEATHING. SHEATHING NAILS SHALL BE DRIVEN SO THEIR HEADS ARE FLUSH WITH SHEATHING (NOT COUNTERSUNK).
- 8 LTP4'S INSTALLED OVER SHEATHING WITH 8d (0.131"Ø x 2-1/2") NAILS MAY BE SUBSTITUTED FOR A35'S AT CONTRACTORS OPTION.
- 9 A35'S OR LTP4'S MAY BE ELIMINATED PER DETAIL A OR DETAIL B.

4

BEARING AND EXTERIOR WALLS			NON-BEARING WALLS		
STUD SIZE	MAX DEPTH OF NOTCH	MAX DIA. OF HOLE	STUD SIZE	MAX DEPTH OF NOTCH	MAX DIA. OF HOLE
2x4	3/4"	1-3/8"	2x4	1-3/8"	2"
2x6	1-1/4"	2-1/8"	2x6	2-1/4"	3-1/4"

HOLE AND NOTCH SIZE FOR NON-BEARING WALLS MAY BE USED FOR BEARING WALLS IF REQUIRED NUMBER OF STUDS ARE DOUBLED. DOUBLE STUDS SHALL BE LIMITED TO TWO SUCCESSIVE STUDS.

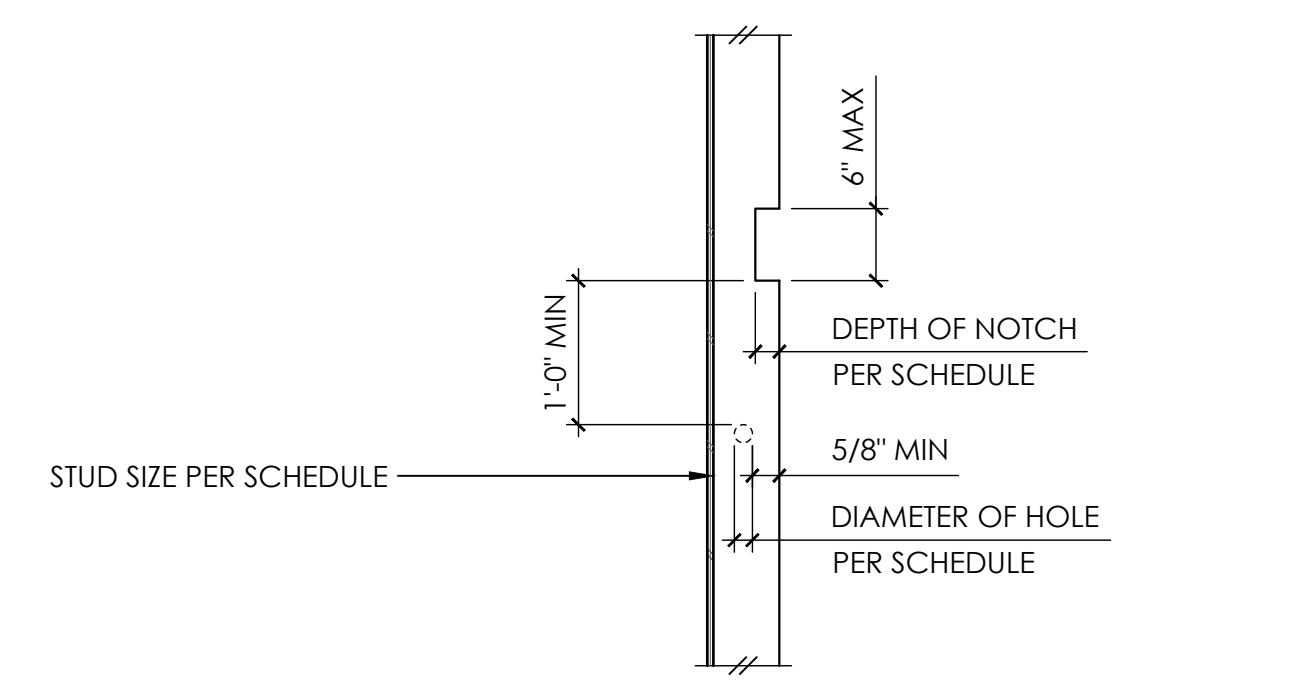

**TYPICAL ALLOWABLE HOLES AND NOTCHES IN WALL STUDS** 5

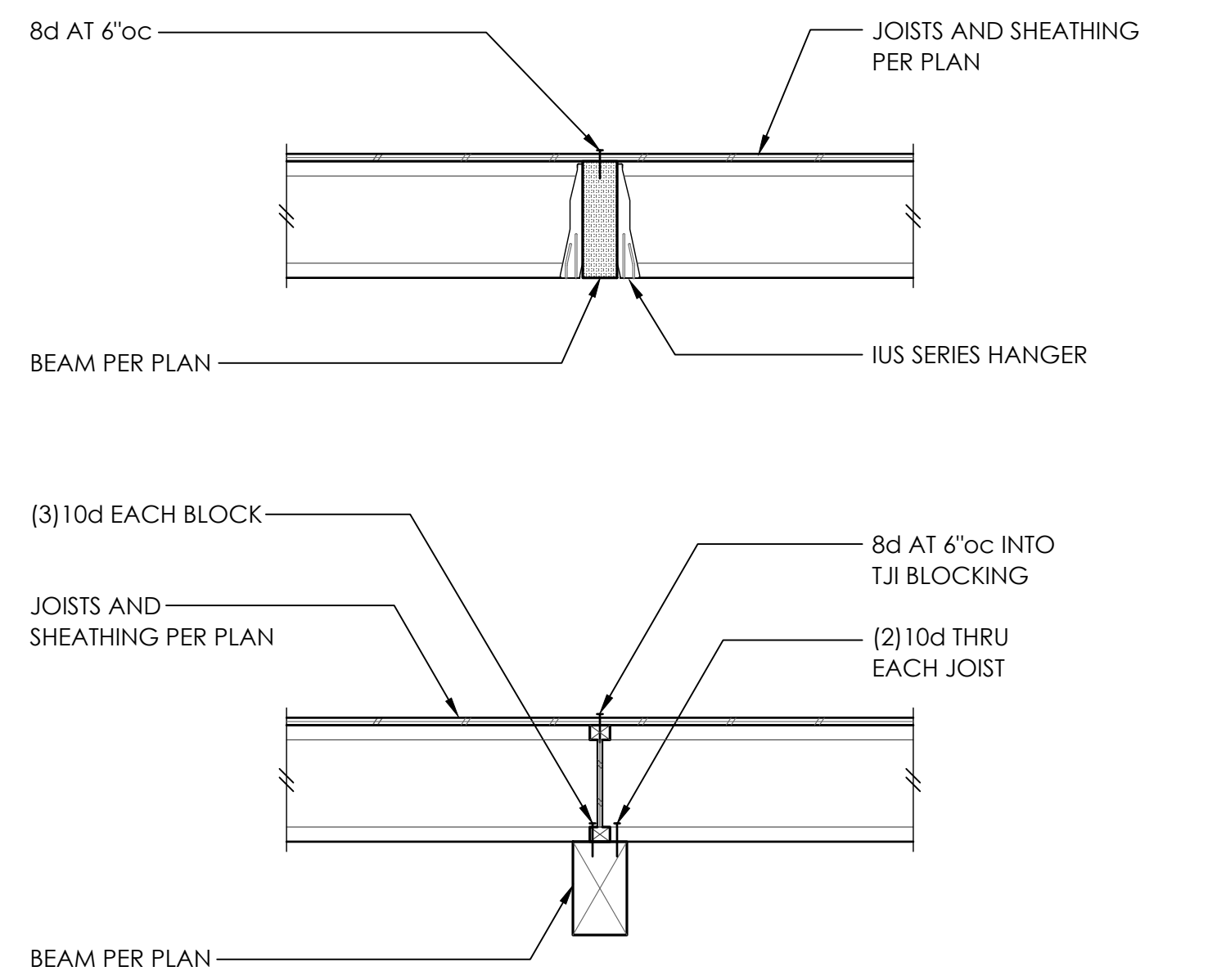

**TYPICAL FLUSH AND DROPPED BEAM** 6

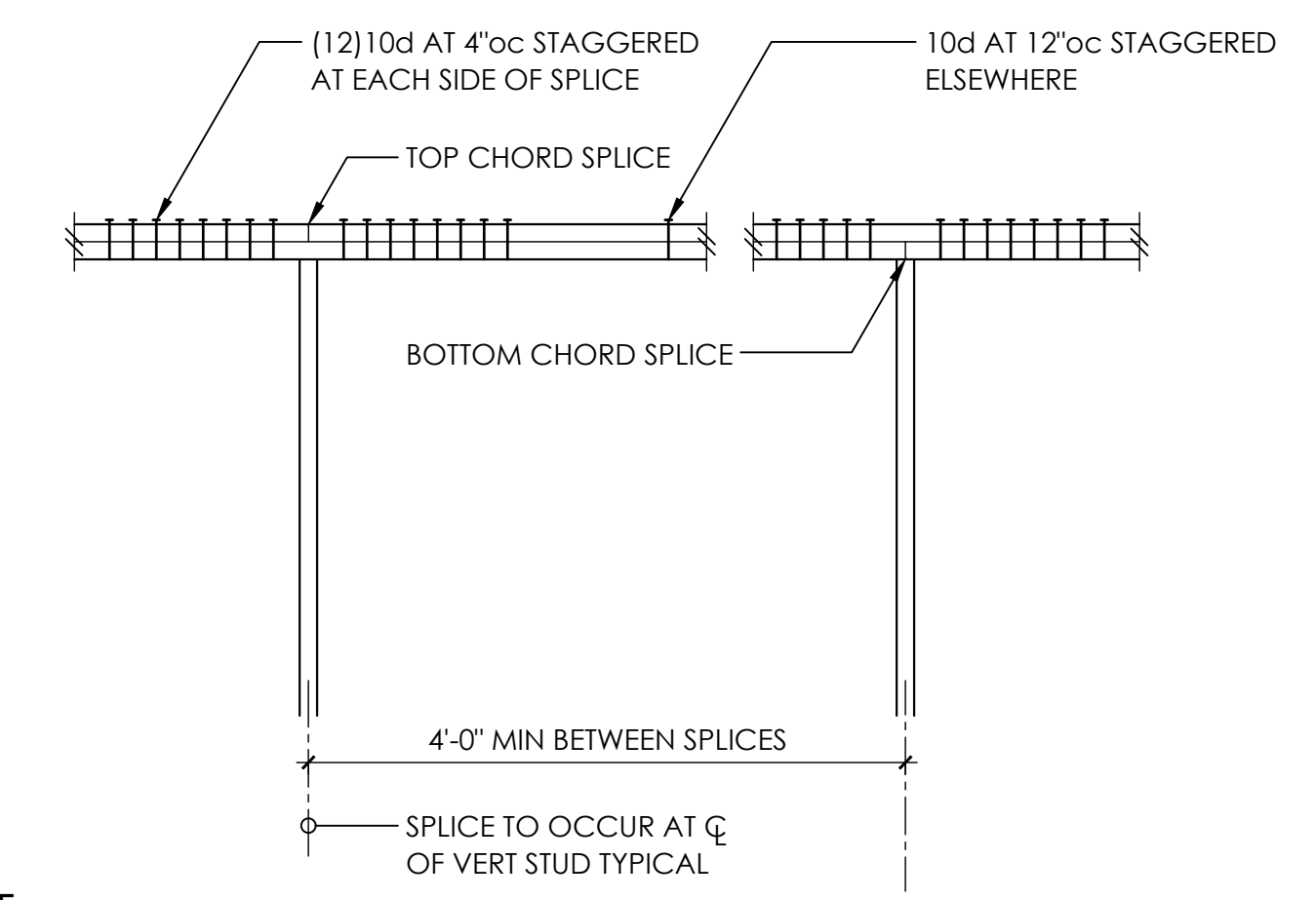

- NOTE:**
- NAILING AT TOP PLATE SPLICES MAY BE ELIMINATED w/ CS16 x 30"
  - WHERE VERTICAL PENETRATIONS THRU PLATE EXCEED 1" FOR A 4x WALL OR 3" FOR A 6x WALL - PROVIDE CS16 x 30" AT TOP PLATE
  - MINIMUM EDGE DISTANCE FOR VERTICAL PENETRATIONS THRU TOP PLATE IS 1-1/4"

**TYPICAL TOP PLATE SPLICE** 7

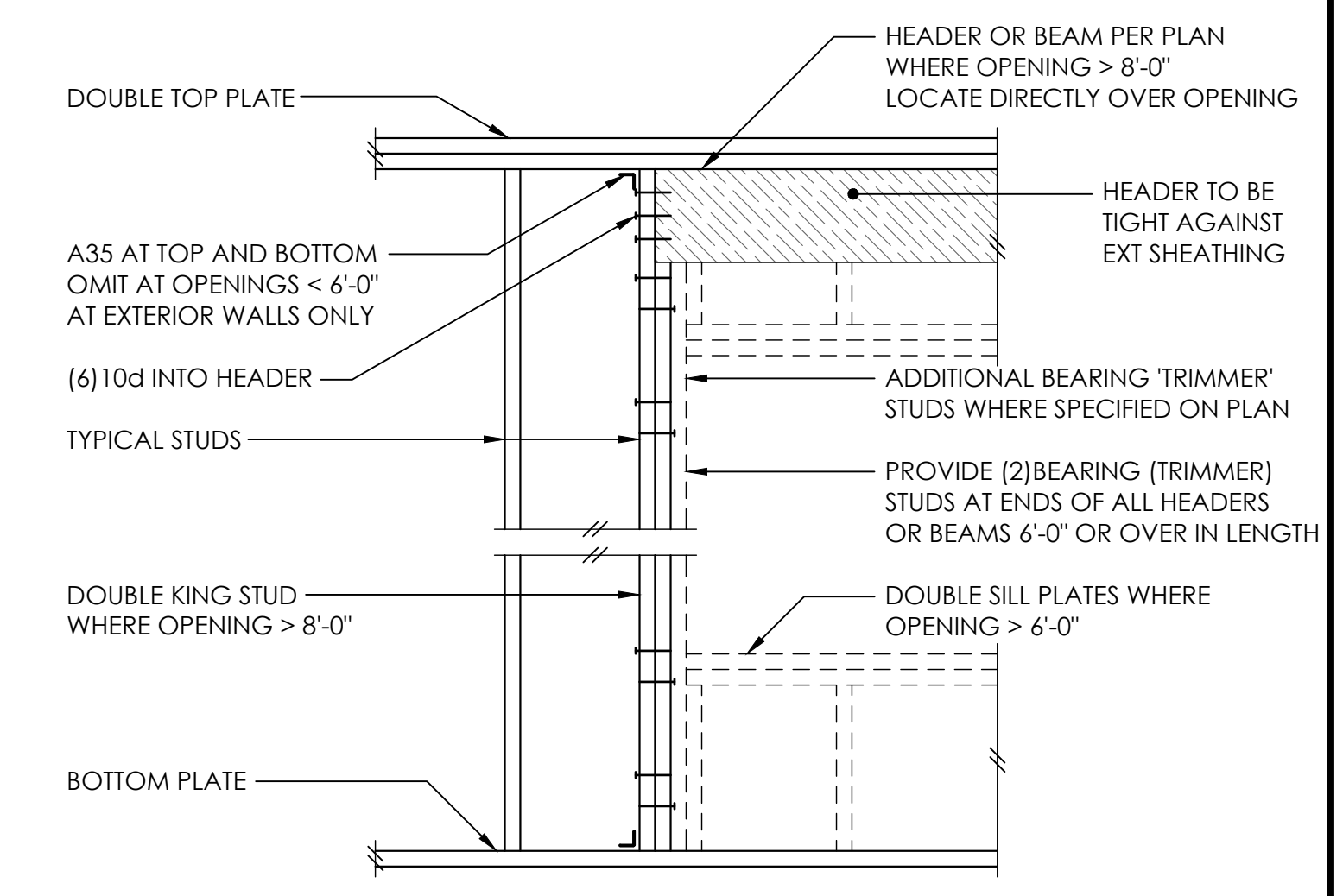

**TYPICAL HEADER SUPPORT** 8

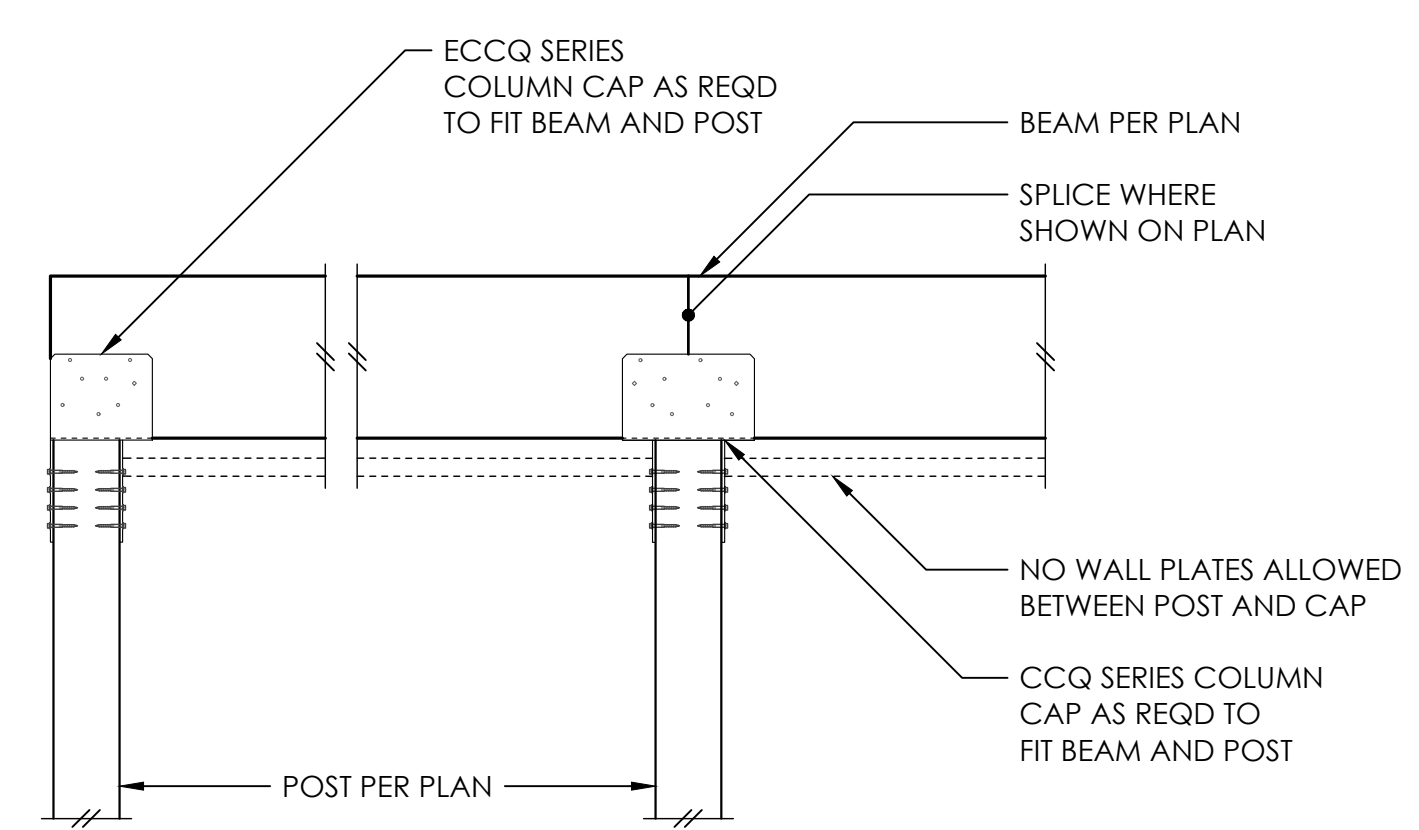

10

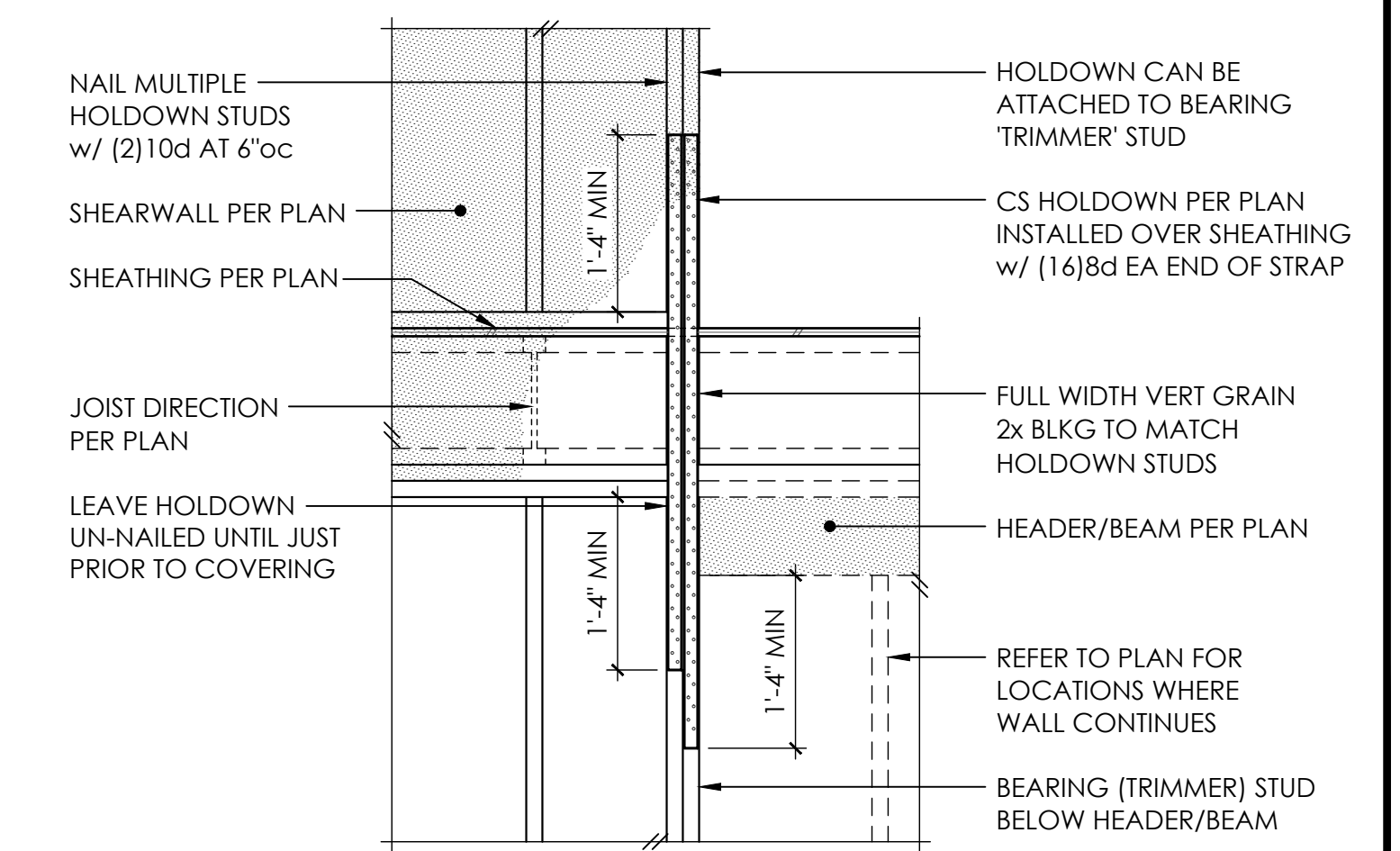

**TYPICAL CS16 HOLDOWN** 12

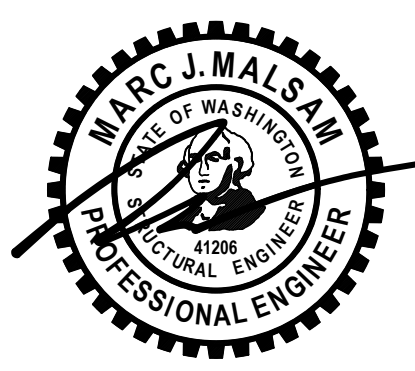

PROJECT NO 0444.2023.09.01  
PROJECT MANAGER WAC  
DRAWN JAS  
ENGINEER GARRETT OSWALD  
206.902.7287  
GARRETTO@MALSAM-TSANG.COM

REV	DESCRIPTION	DATE
	PERMIT SET	7.12.23
	PERMIT CORRECTIONS	12.01.23
	PLAN REVISIONS	2.09.24

ARCH MN CUSTOM HOMES  
425.394.3848

**TYPICAL WOOD FRAMING DETAILS**



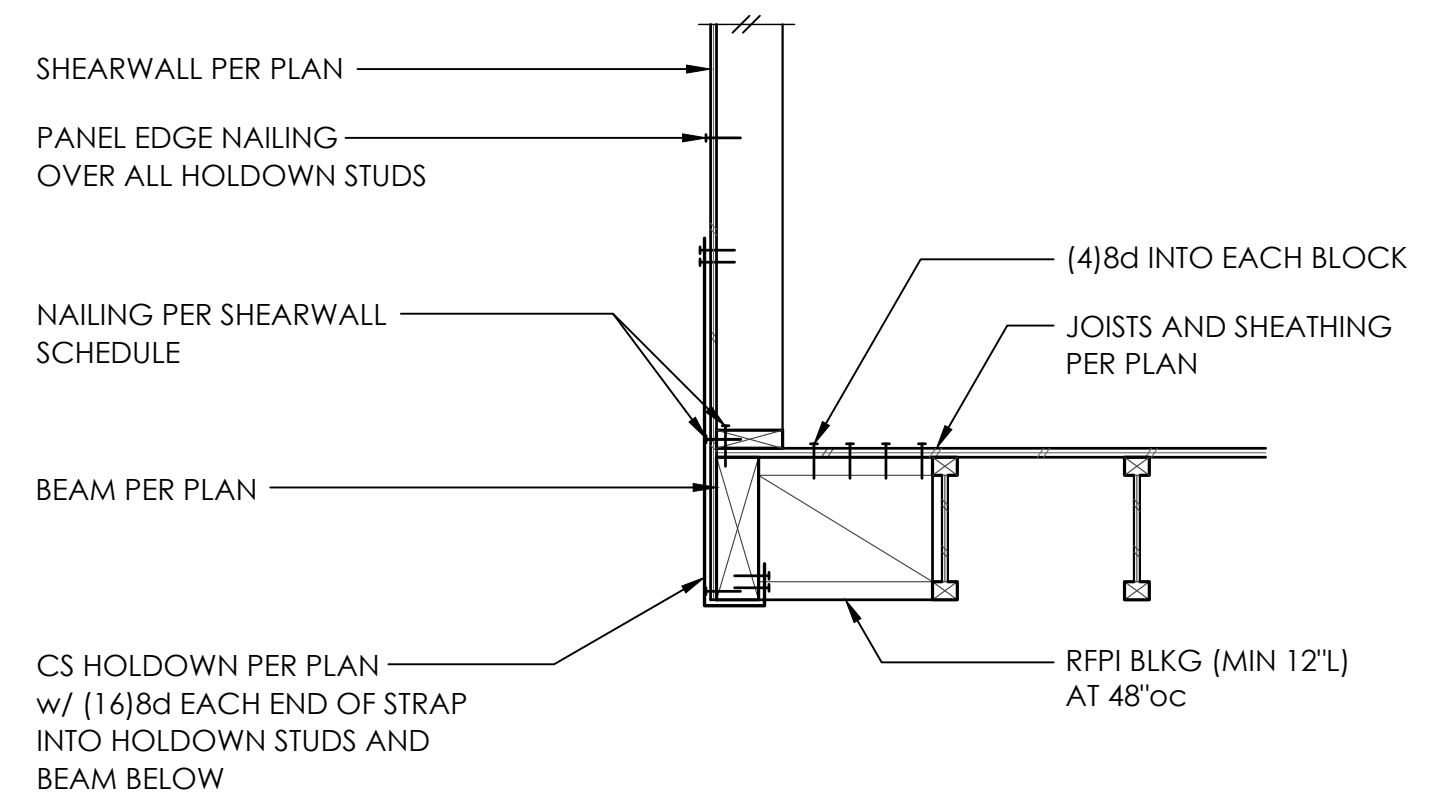

1

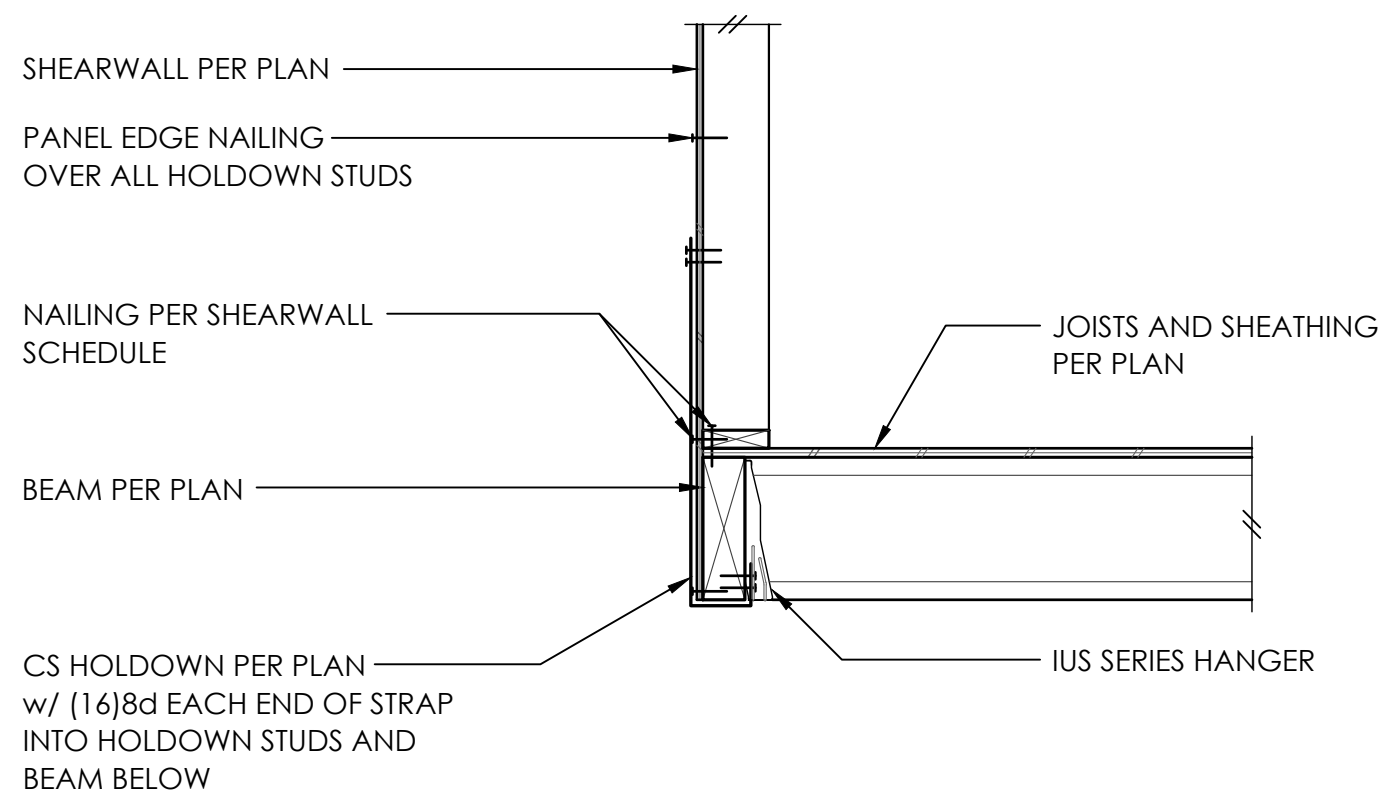

2

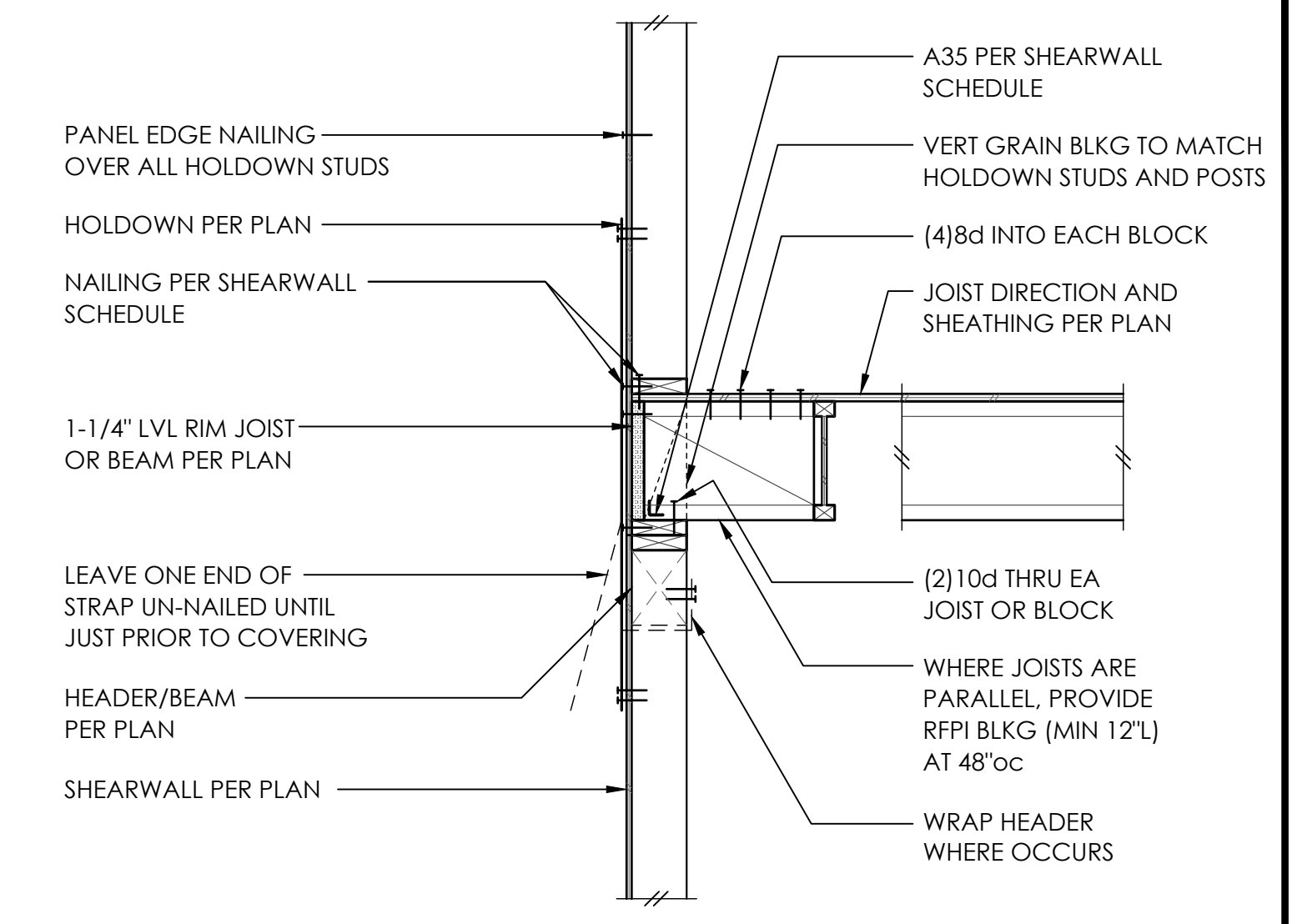

3

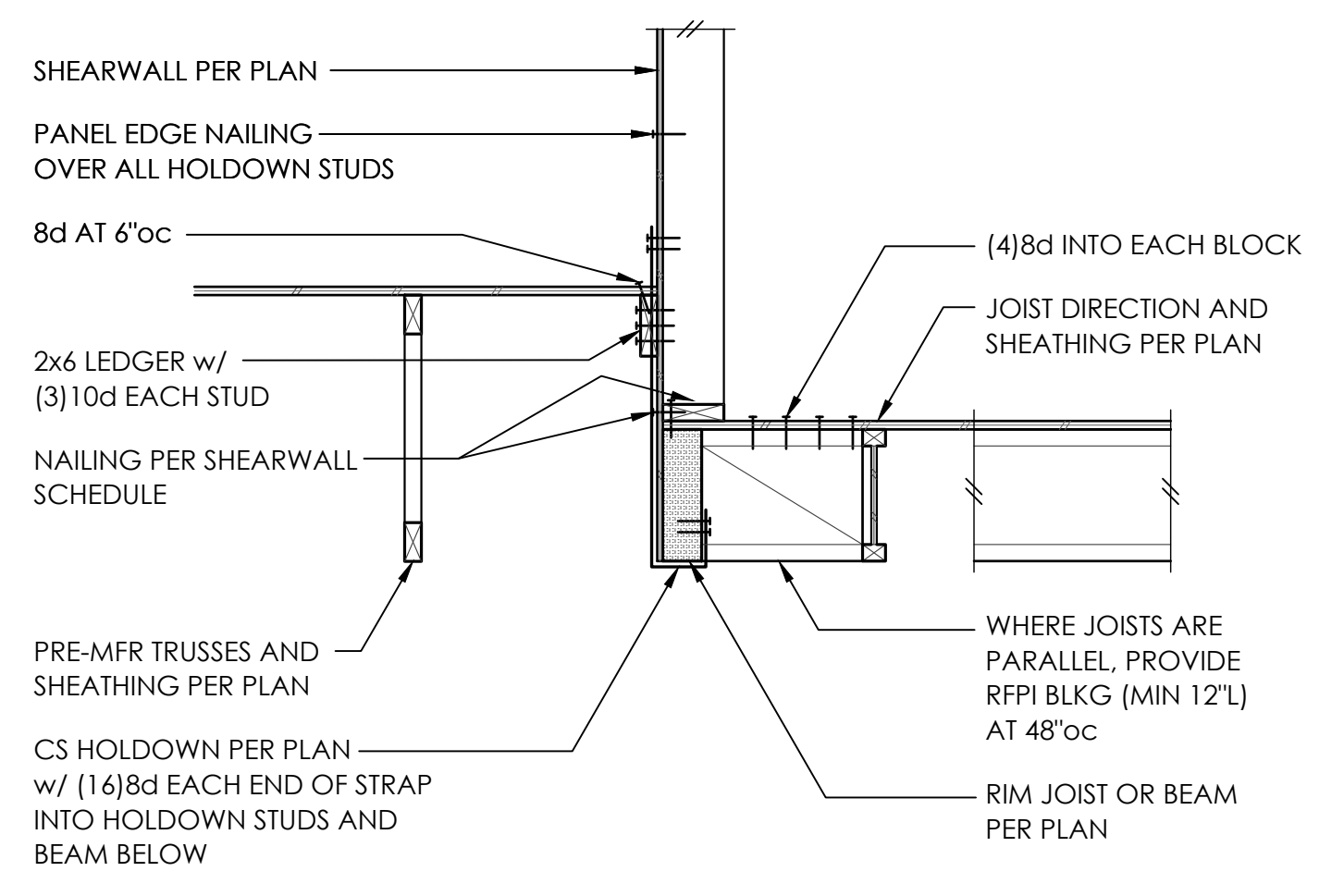

4

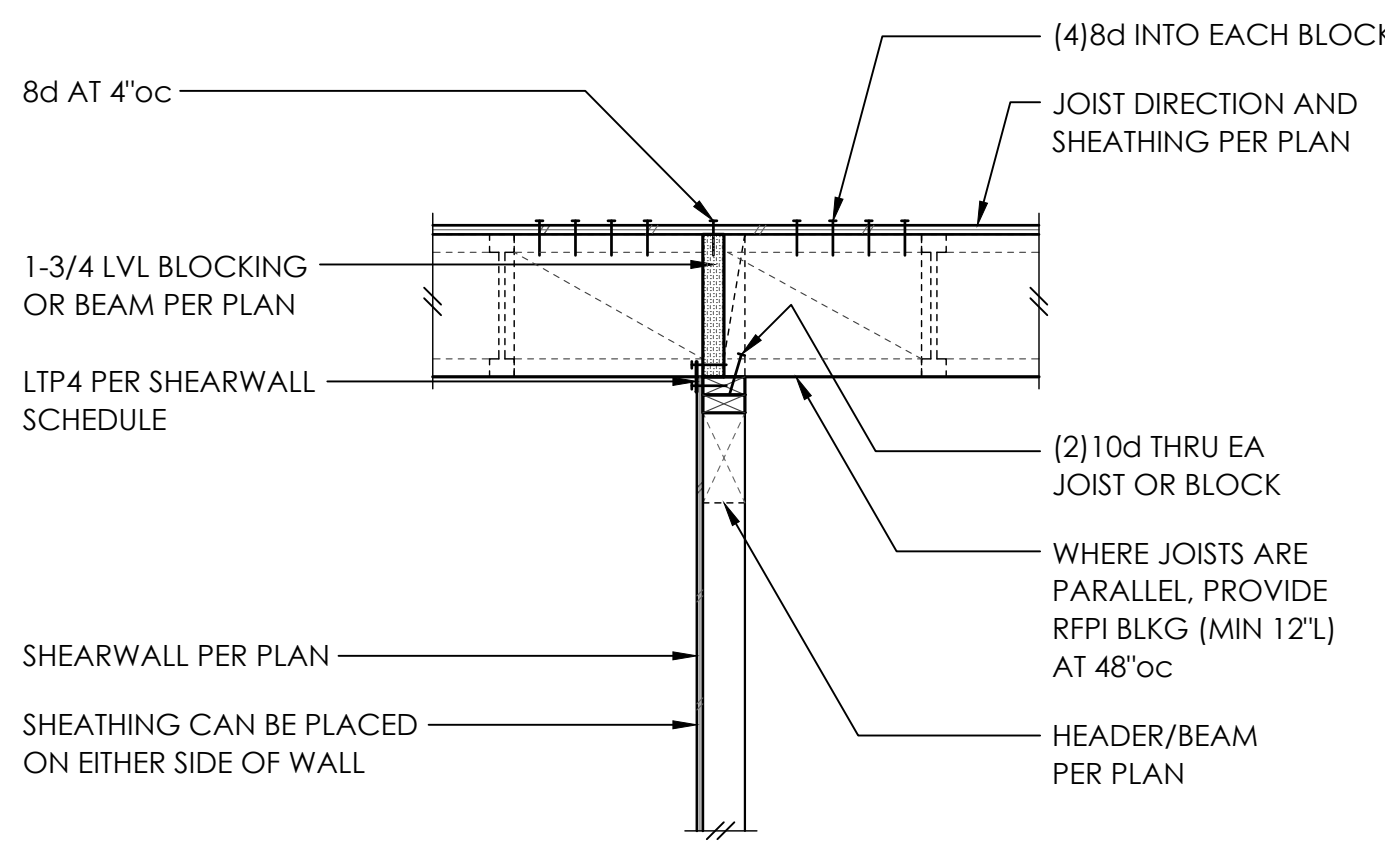

5

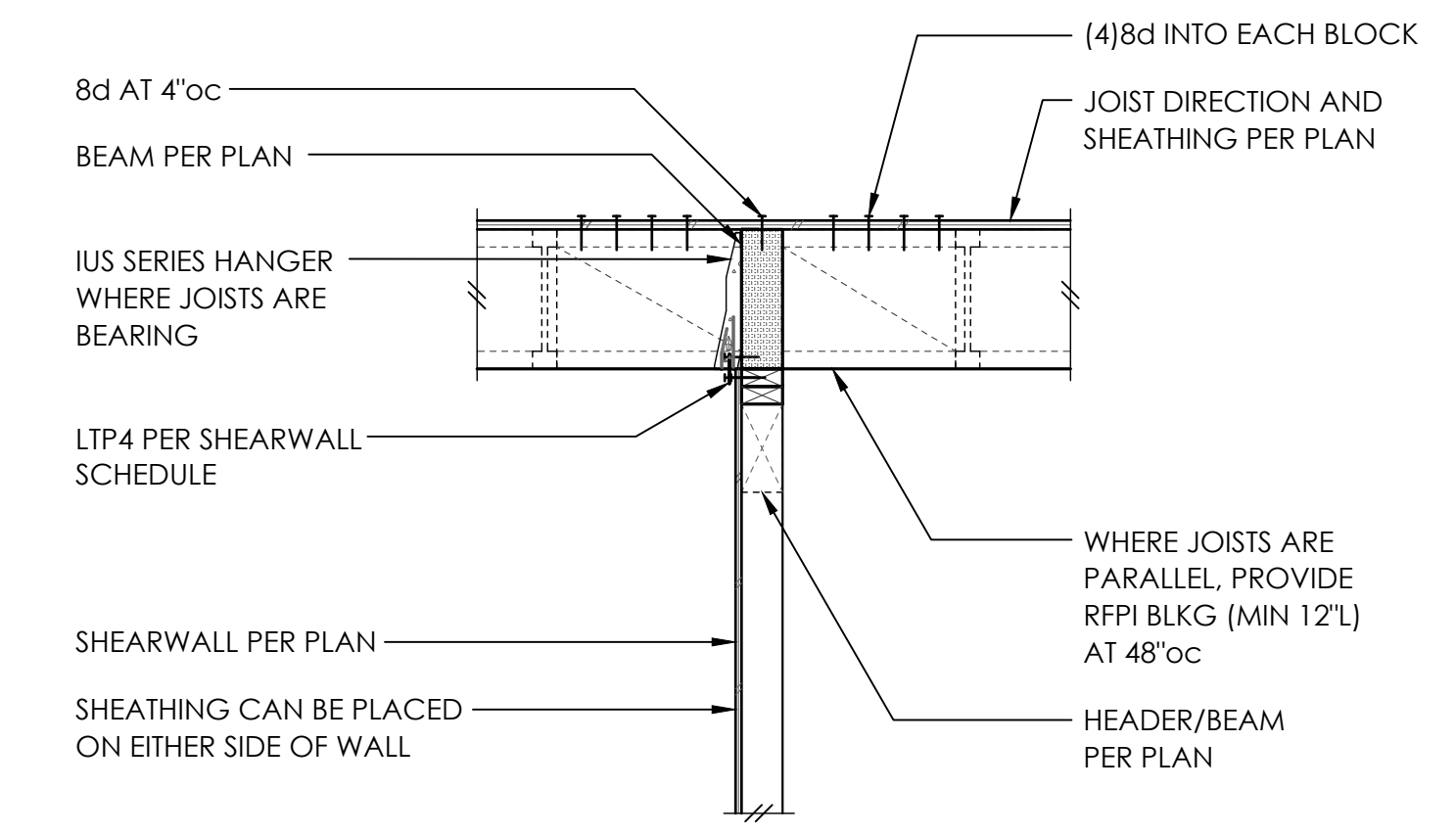

6

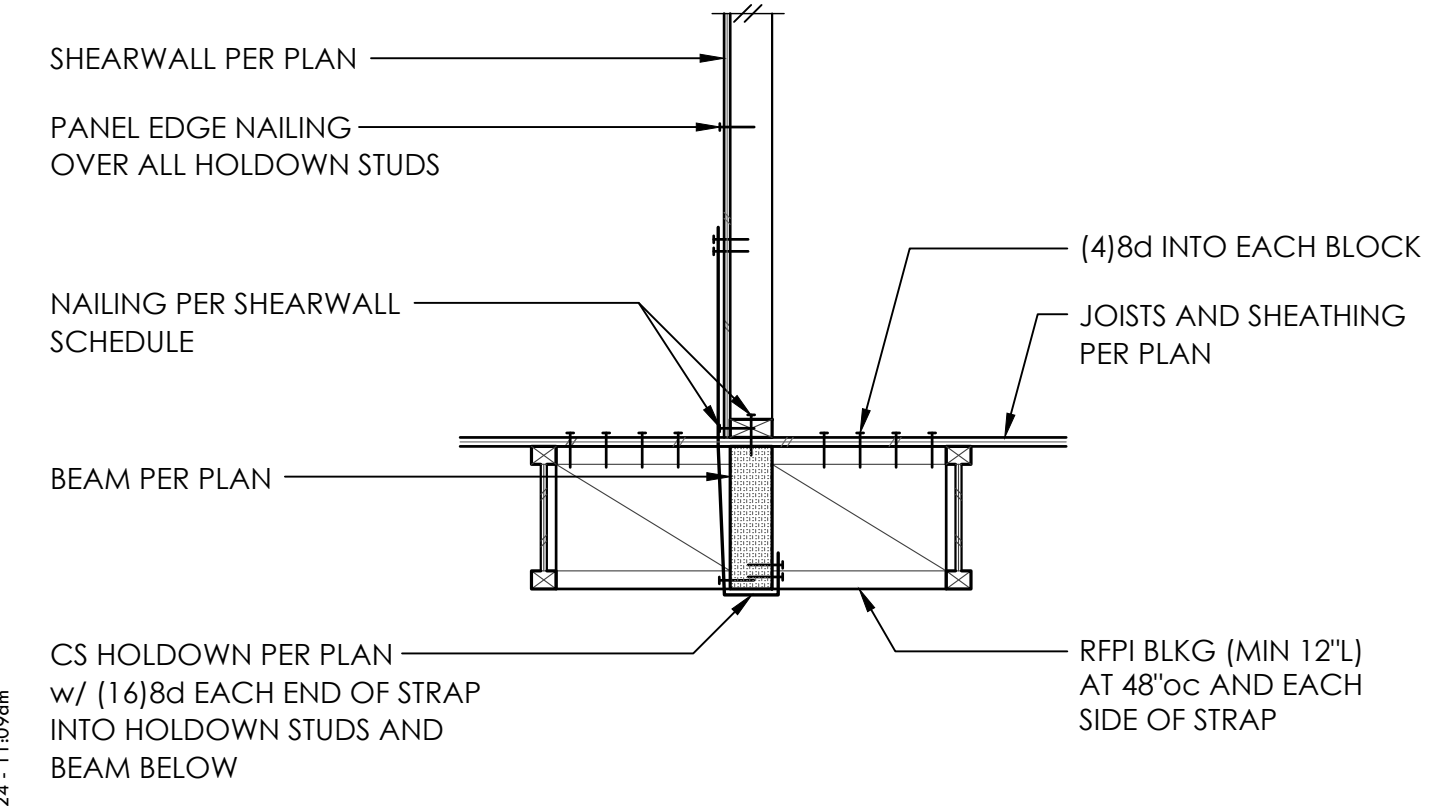

7

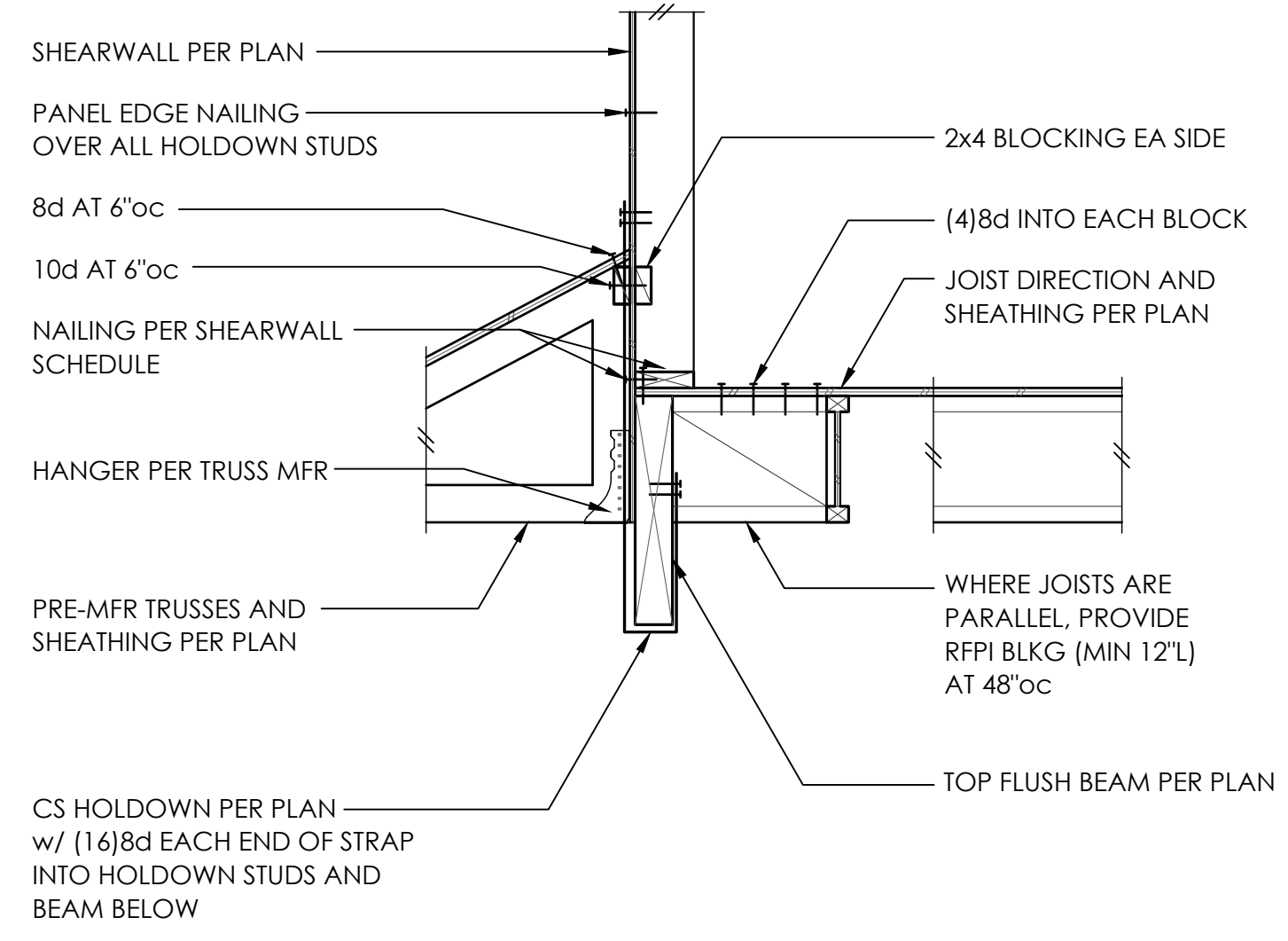

8

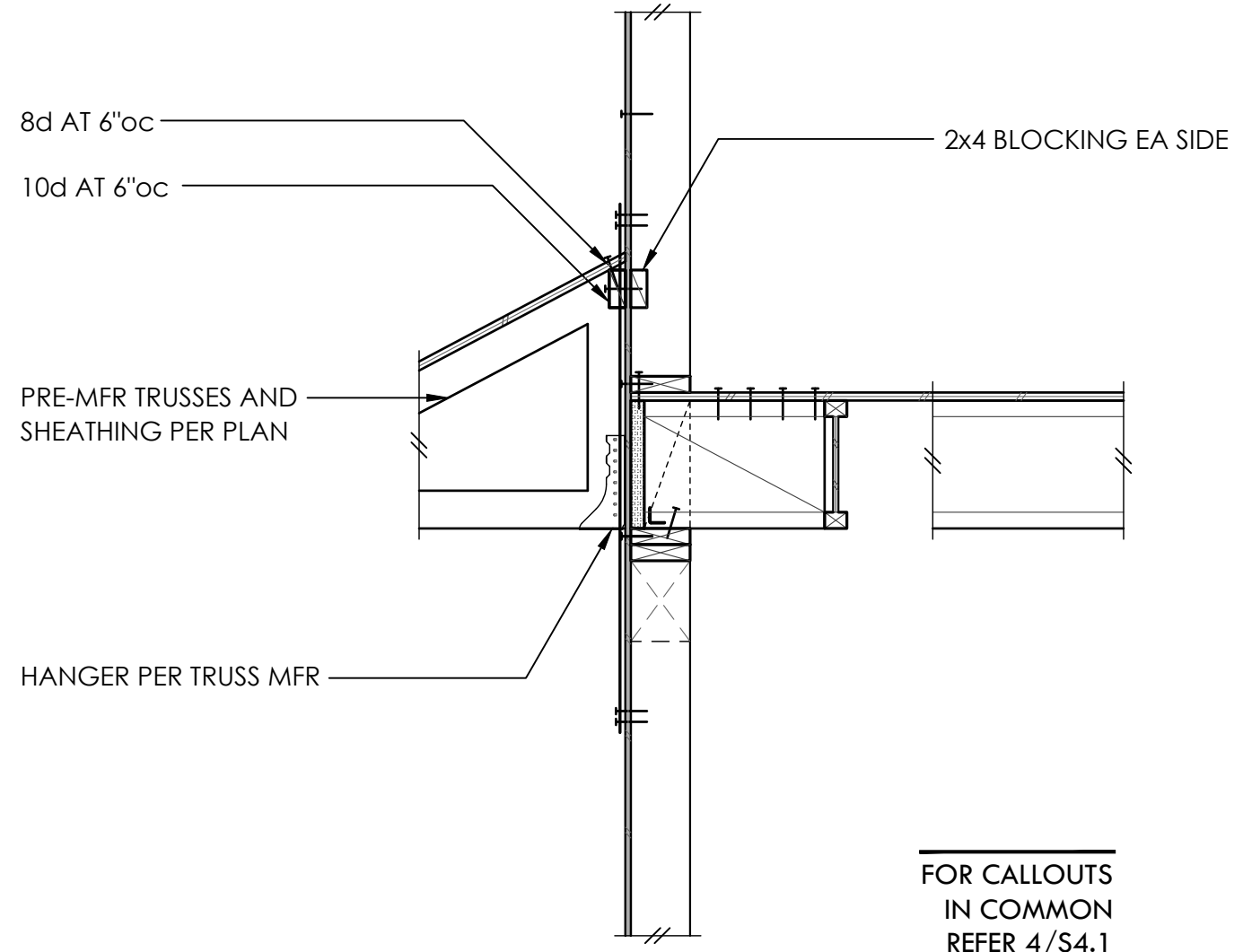

9

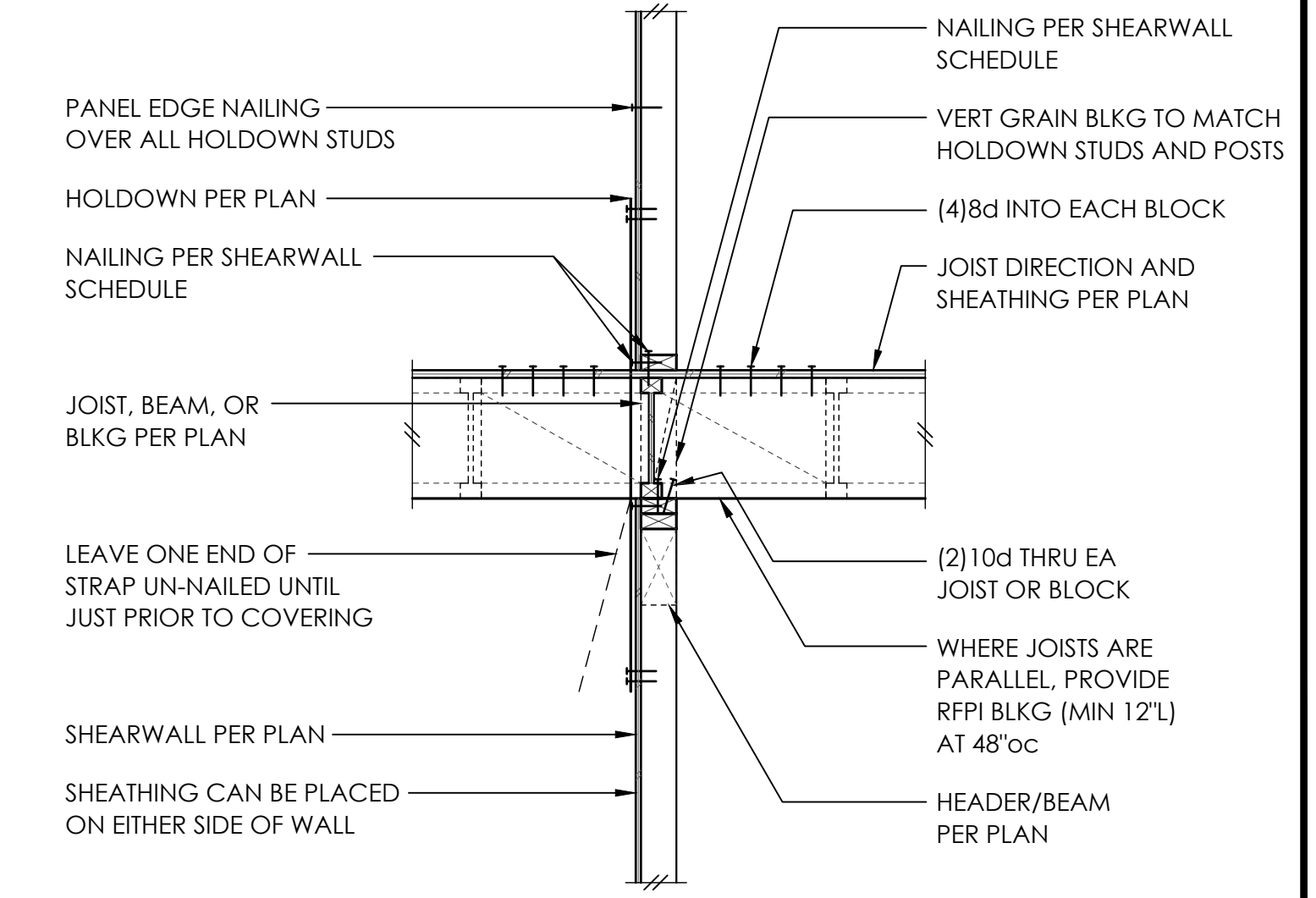

10

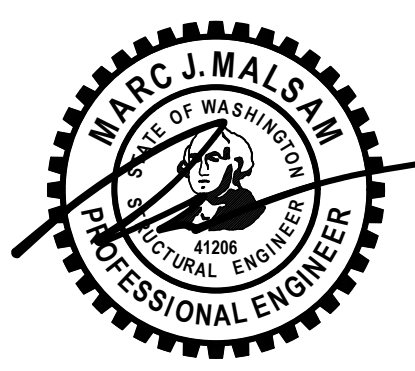

PROJECT NO	0444.2023.09.01	
PROJECT MANAGER	WAC	
DRAWN	JAS	
ENGINEER	GARRETT OSWALD	
	206.902.7287	
	GARRETTO@MALSAM-TSANG.COM	
REV	DESCRIPTION	DATE
	PERMIT SET	7.12.23
	PERMIT CORRECTIONS	12.01.23
	PLAN REVISIONS	2.09.24

ARCH MN CUSTOM HOMES  
425.394.3848

**WOOD FRAMING  
DETAILS**



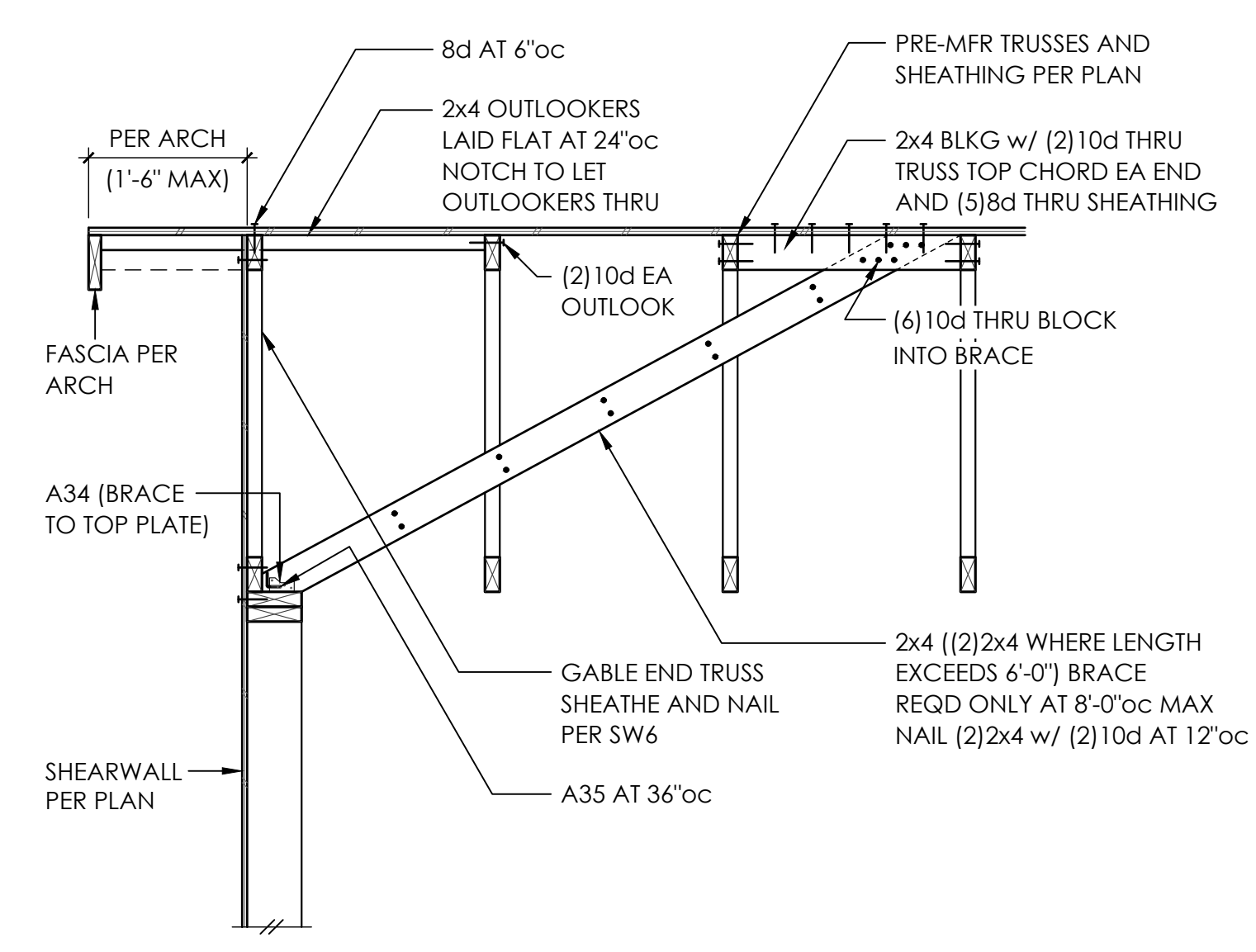

1

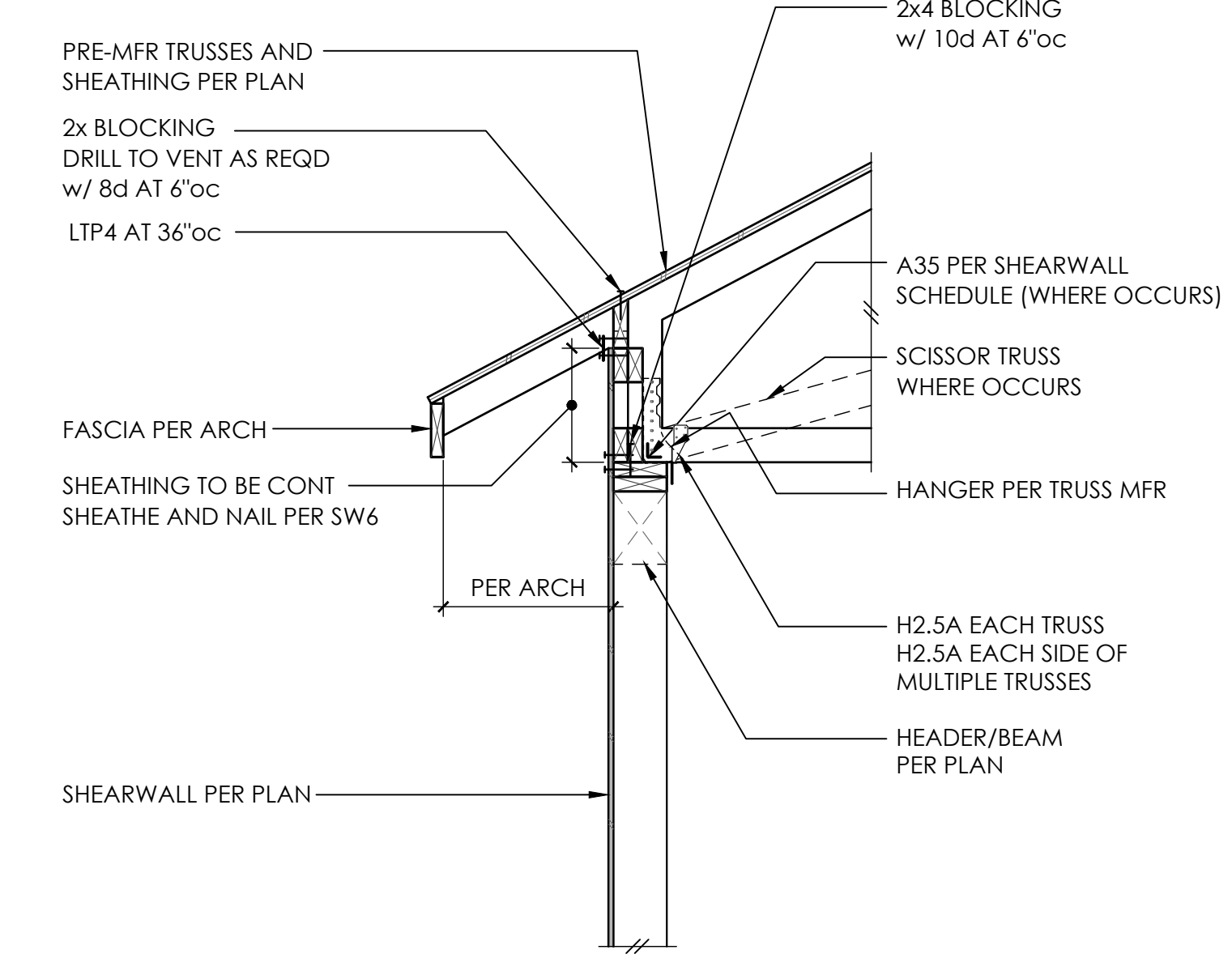

3

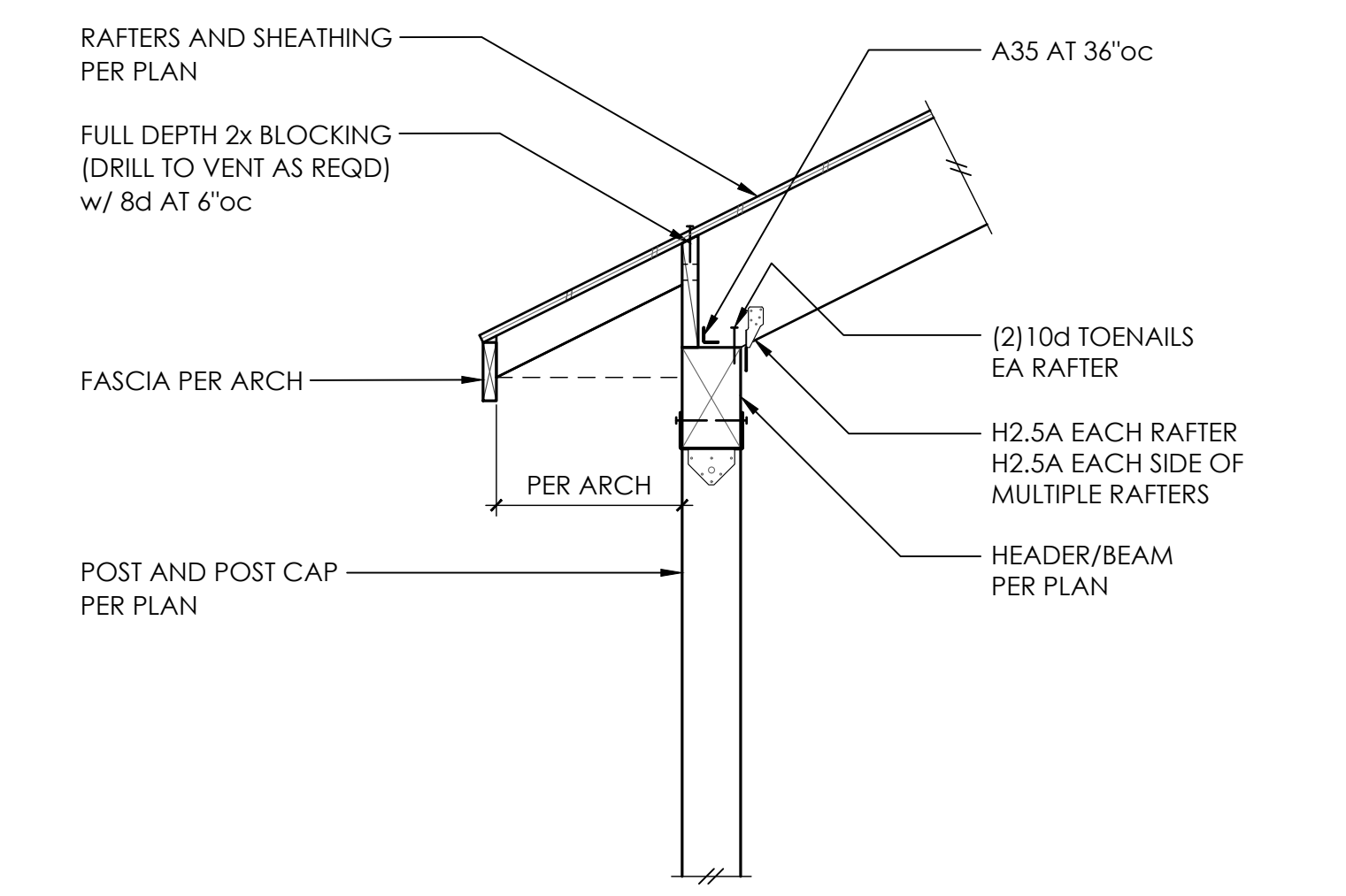

5

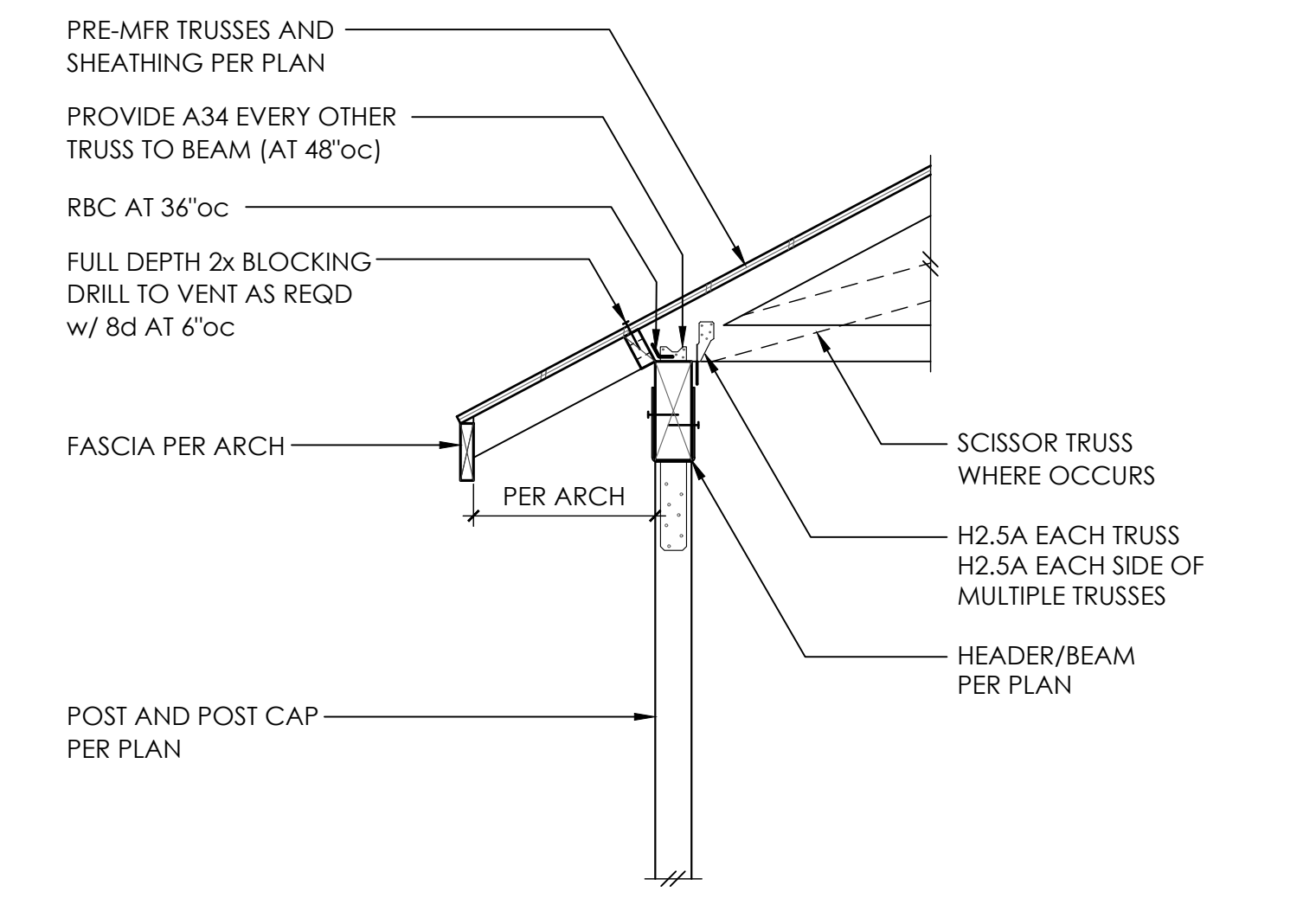

7

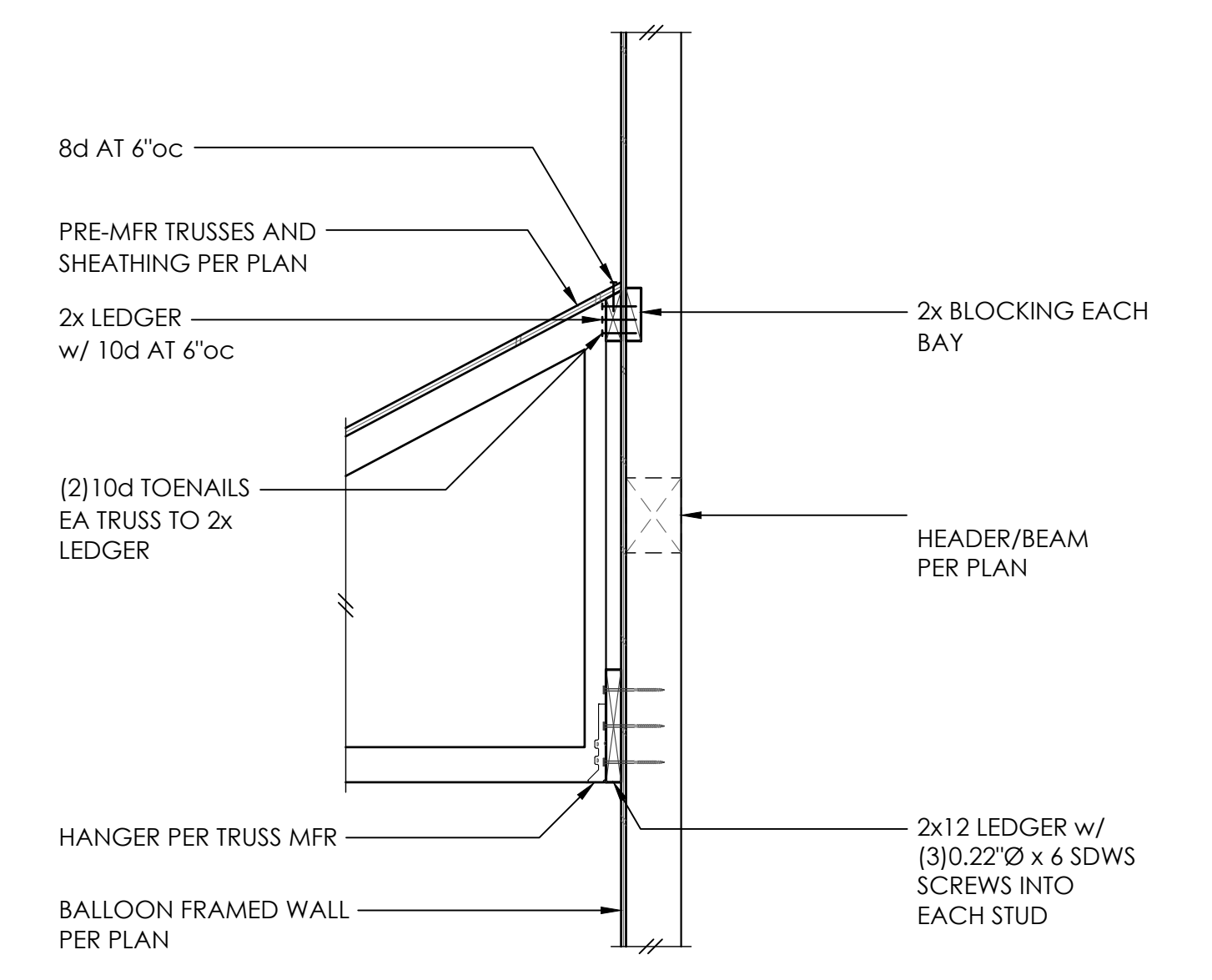

9

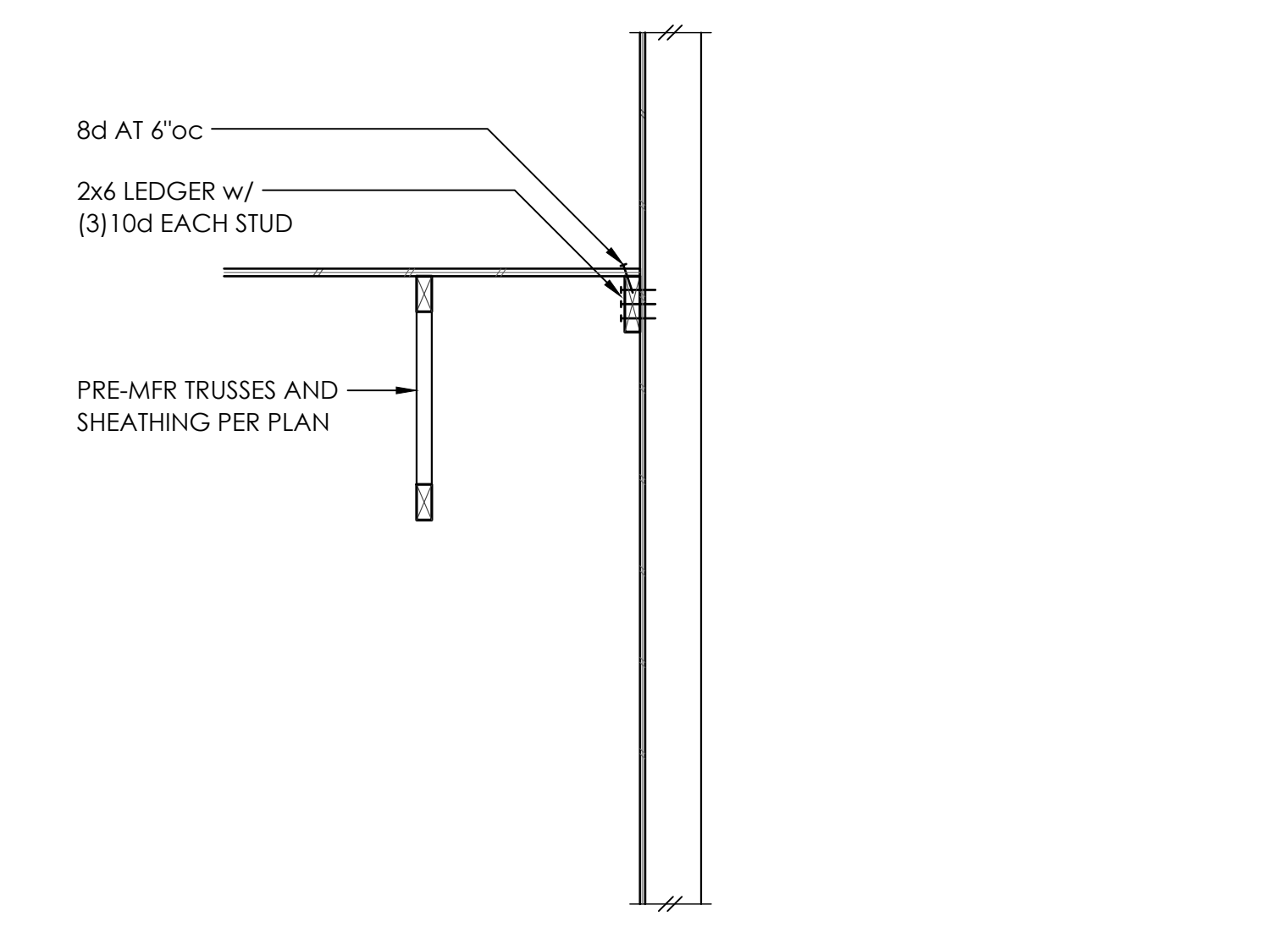

10

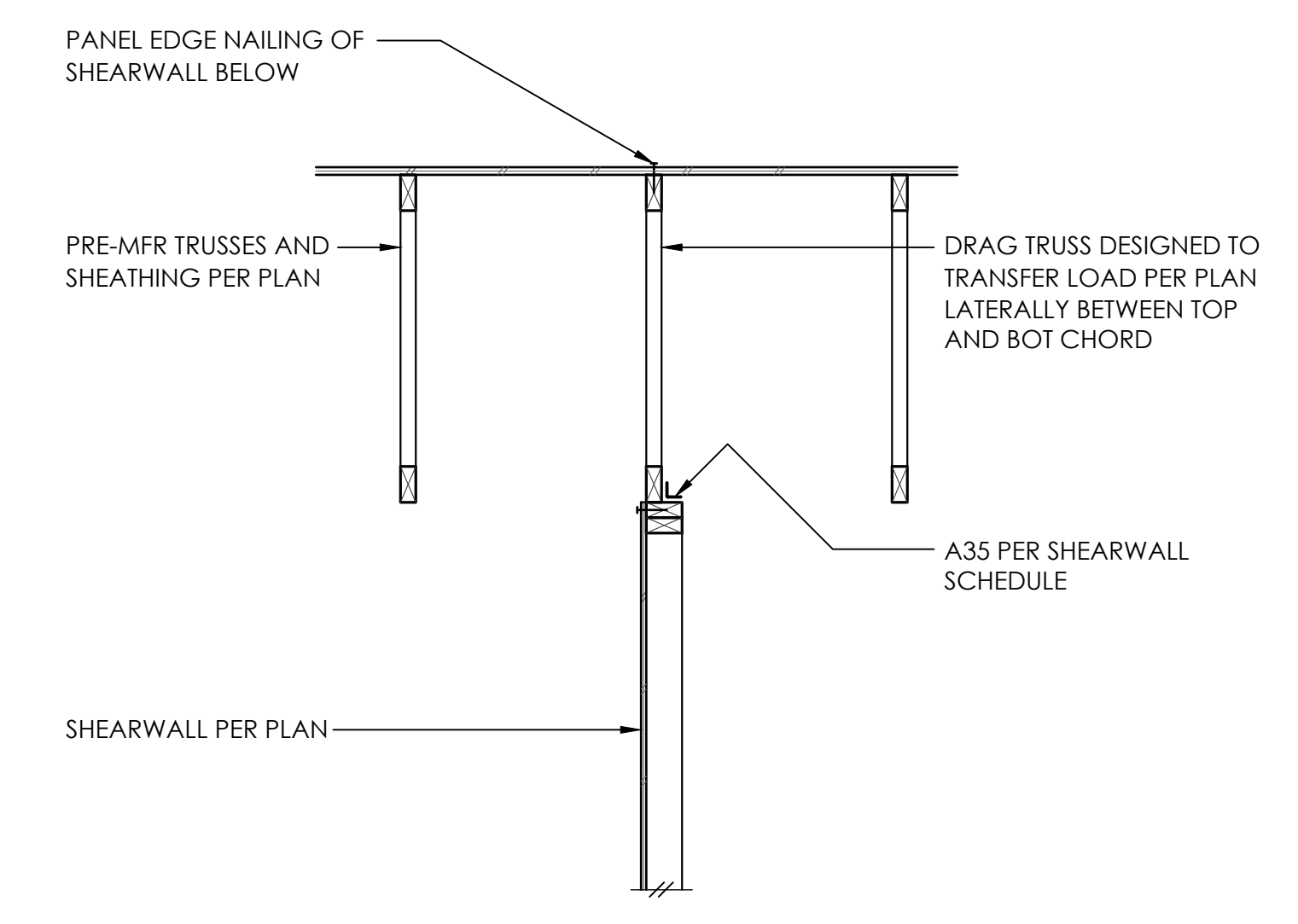

11

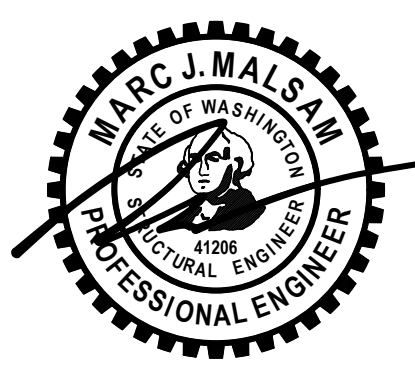

PROJECT NO 0444.2023.09.01  
PROJECT MANAGER WAC  
DRAWN JAS  
ENGINEER GARRETT OSWALD  
206.902.7287  
GARRETTO@MALSAM-TSANG.COM

REV	DESCRIPTION	DATE
	PERMIT SET	7.12.23
	PERMIT CORRECTIONS	12.01.23
	PLAN REVISIONS	2.09.24

ARCH MN CUSTOM HOMES  
425.394.3848

**WOOD FRAMING  
DETAILS**

**S4.2**  
SCALE - 3/4" = 1'-0"

12



**LEGAL DESCRIPTION**

PER WARRANTY DEED UNDER RECORDING NUMBER 20141229001480)  
 LOT 6, BLOCK 2, WAMBA'S FIRST ADDITION TO MERCER ISLAND ACCORDING TO THE PLAT THEREOF RECORDED IN VOLUME 55 OF PLATS, PAGE 84, RECORDS OF KING COUNTY, WASHINGTON SITUATED IN THE COUNTY OF KING, STATE OF WASHINGTON.

**SOIL AMENDMENT REQUIRED**

COMPOST AMENDED SOIL REQUIRED ON ALL LANDSCAPED AREAS AFTER CONSTRUCTION. SEE DETAIL ON C3.5.

**SOIL INSPECTION REQUIRED BY ENGINEER**

A POST CONSTRUCTION INSPECTION & CERTIFICATION OF AMENDED SOILS IS REQUIRED BY A LICENSED CIVIL ENGINEER. THIS IS REQUIRED BEFORE FINAL SIGN-OFF BY CITY.

**MINIMUM 10% ORGANIC MULCH & COMPOST SOIL REQUIRED**

**EROSION CONTROL LEGEND**

LIMITS OF DISTURBANCE	
FILTER FABRIC FENCE (SILT FENCE)	(SF) ——— X ——— X ———
STABILIZED CONSTRUCTION ENTRANCE	(CE) [Pattern]
CATCH BASIN INLET PROTECTION	(IP) [Square]
INTERCEPTOR SWALE SEE COR DWG 504, TYPE A TEMPORARY SWALE	(IS) ← ——— ——— →
TREE PROTECTION FENCING	(TP) ——— O ——— O ———
CHECK DAM	(CD) [Symbol]
STRAW WATTLES	(SW)   USE AS NEEDED
MULCHING, MATTING, & COMPOST BLANKETS	(MU) [Symbol]

**TREE PROTECTION DETAIL**

**TREE PROTECTION AREA (TPZ)**  
**KEEP OUT!**  
**DO NOT REMOVE OR ADJUST THE APPROVED LOCATION OF THIS TREE PROTECTION AREA**

Trees enclosed by this fence are protected and are subject to the conditions of the tree permit. Violation of tree conditions may lead to:

- Correction Notices or Stop Work Orders until compliance is achieved
- RE Inspection Fees/financial penalties
- Arborist reports recommending mitigation

**Notes**

- No pruning shall be performed unless under the direction of the Project Arborist. Including limbing trees up.
- No grading, excavation, storage (materials, equipment, vehicles, etc.), or other unpermitted activity shall occur inside the protective fencing.
- Penalties for damaging by root damage/compaction or removing a saved tree may be a fine up to three times the value of the tree plus restoration (MICC 19.10.160).
- Any work in approved TPZ must be with the permission of the City Arborist (206) 275-7713, [john.kenney@mercergov.org](mailto:john.kenney@mercergov.org).
- 5" course woodchips within the tree protection zone, but not against the tree trunk.

Tree protection fence: 4-6" chain link fence, solidly anchored into the ground, or if authorized High-density polyethylene fencing with 3.5" x 1.5" openings; color orange. Steel posts installed at 8' o.c.

2" x 6" steel posts or approved equal

Maintain existing grade with the tree protection fence unless otherwise indication on the plans

Any Work in the protected area must be with the permission of the City Arborist [john.kenney@mercergov.org](mailto:john.kenney@mercergov.org)

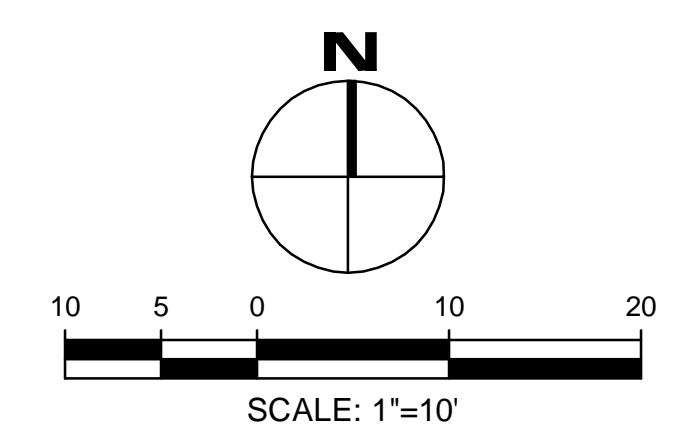

**PROJECT ARBORIST**  
 SHOFFNER CONSULTING  
 TONY SHOFFNER  
 PHONE: 206.755.9407 (CELL)  
 TONY@TONYSHOFFNER.COM

**TREE INVENTORY**  
 SEE SHEET C1.2

80th Avenue SE

SE 72nd Street

#2308-116

NO.	DATE	BY	REVISIONS

APPLICANT  
 HOME PROJECT 472 LLC  
 MN CUSTOM HOMES  
 CONTACT: JACOB SOUTHARD  
 3006 112th AVE NE, SUITE #100  
 BELLEVUE, WA 98004  
 PH: 425-429-6645  
 permits@mncustom.com

DATE: Apr 11, 2024  
 JOB# 0472  
 DRAFTED: SS DESIGN: SS  
 DIGITAL SIGNATURE

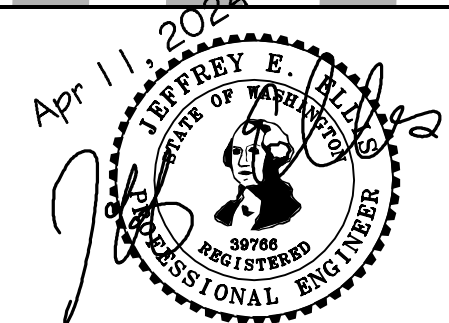

**CIVIL ENGINEERING SOLUTIONS**  
 701 N 36th STREET, SUITE 450 SEATTLE, WA 98103  
 PHONE: 206.930.0342 DUFFY@CESOLUTIONS.US

TESC PLAN

HOME #472 by MN CUSTOM HOMES  
 7119 80th AVENUE SE, MERCER ISLAND, WA 98040

DRAWING NO:  
**C1.0**  
 APN 915970-0050  
 #2308-116



**SILT FENCE DETAIL** **DOE**

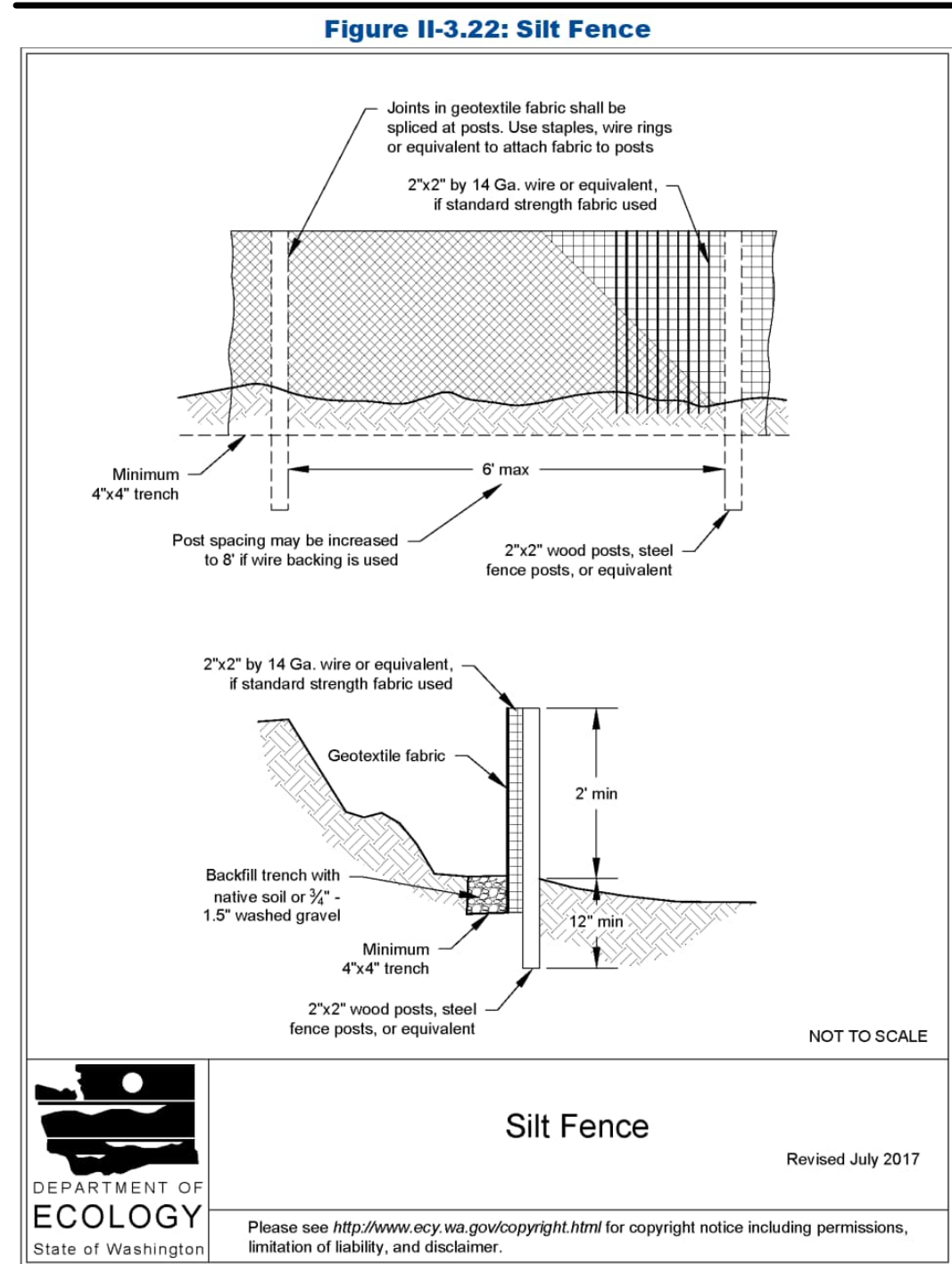

**RECOMMENDED CONSTRUCTION SEQUENCE**

A DETAILED CONSTRUCTION SEQUENCE IS NEEDED TO ENSURE THAT EROSION AND SEDIMENT CONTROL MEASURES ARE APPLIED AT THE APPROPRIATE TIMES. A RECOMMENDED CONSTRUCTION SEQUENCE IS PROVIDED BELOW.

- HOLD AN ONSITE PRE-CONSTRUCTION MEETING.
- POST SIGN WITH NAME AND PHONE NUMBER OF ESC SUPERVISOR (MAY BE CONSOLIDATED WITH THE REQUIRED NOTICE OF CONSTRUCTION SIGN).
- FLAG OR FENCE CLEARING LIMITS.
- INSTALL CATCH BASIN PROTECTION, IF REQUIRED.
- GRADE AND INSTALL CONSTRUCTION ENTRANCE(S).
- INSTALL PERIMETER PROTECTION (SILT FENCE, BRUSH BARRIER, ETC.).
- CONSTRUCT SEDIMENT PONDS AND TRAPS.
- GRADE AND STABILIZE CONSTRUCTION ROADS.
- CONSTRUCT SURFACE WATER CONTROLS (INTERCEPT DIKES, PIPE SLOPE DRAINS, ETC.) SIMULTANEOUSLY WITH CLEARING AND GRADING FOR PROJECT DEVELOPMENT.
- MAINTAIN EROSION CONTROL MEASURES IN ACCORDANCE WITH CITY OF MERCER ISLAND STANDARDS AND MANUFACTURER'S RECOMMENDATIONS.
- RELOCATE SURFACE WATER CONTROLS OR TESC MEASURES, OR INSTALL NEW MEASURES SO THAT AS SITE CONDITIONS CHANGE, THE TESC IS ALWAYS IN ACCORDANCE WITH CITY OF MERCER ISLAND TESC REQUIREMENTS.
- COVER ALL AREAS THAT WILL BE UN-WORKED FOR MORE THAN SEVEN DAYS DURING THE DRY SEASON (MAY 1 TO SEPT 30) OR TWO DAYS DURING THE WET SEASON (OCT 1 TO APRIL 30) WITH STRAW, WOOD FIBER MULCH, COMPOST, PLASTIC SHEETING, OR EQUIVALENT.
- STABILIZE ALL AREAS WITHIN SEVEN DAYS OF REACHING FINAL GRADE.
- SEED, SOD, STABILIZE, OR COVER ANY AREAS TO REMAIN UNWORKED FOR MORE THAN 30 DAYS.
- UPON COMPLETION OF THE PROJECT, STABILIZE ALL DISTURBED AREAS AND REMOVE BMPs IF APPROPRIATE.

**DENUDED AREAS REQUIREMENTS**

APRIL 1 TO SEPT 30  
ALL DENUDED AREAS MUST BE STABILIZED WITHIN 7 DAYS OF CONSTRUCTION. PLEASE READ ALL CITY TESC NOTES ON SHEET C1.2.

OCT 1 TO MARCH 31  
ALL DENUDED AREAS MUST BE STABILIZED WITHIN 2 DAYS OF GRADING. IF AN EROSION PROBLEM ALREADY EXISTS ON THE SITE, OTHER COVER PROTECTION AND EROSION CONTROL WILL BE REQUIRED.

**EROSION CONTROL NOTES**

- D.8.2 STANDARD ESC PLAN NOTES  
THE STANDARD ESC PLAN NOTES MUST BE INCLUDED ON ALL ESC PLANS. AT THE APPLICANT'S DISCRETION, NOTES THAT IN NO WAY APPLY TO THE PROJECT MAY BE OMITTED; HOWEVER, THE REMAINING NOTES MUST NOT BE RENUMBERED. FOR EXAMPLE, IF ESC NOTE #3 WERE OMITTED, THE REMAINING NOTES SHOULD BE NUMBERED 1, 2, 4, 5, 6, ETC.
- APPROVAL OF THIS EROSION AND SEDIMENTATION CONTROL (ESC) PLAN DOES NOT CONSTITUTE AN APPROVAL OF PERMANENT ROAD OR DRAINAGE DESIGN (E.G., SIZE AND LOCATION OF ROADS, PIPES, RESTRICTORS, CHANNELS, RETENTION FACILITIES, UTILITIES, ETC.).
  - THE IMPLEMENTATION OF THESE ESC PLANS AND THE CONSTRUCTION, MAINTENANCE, REPLACEMENT, AND UPGRADING OF THESE ESC FACILITIES IS THE RESPONSIBILITY OF THE APPLICANT/ESC SUPERVISOR UNTIL ALL CONSTRUCTION IS APPROVED.
  - THE BOUNDARIES OF THE CLEARING LIMITS SHOWN ON THIS PLAN SHALL BE CLEARLY FLAGGED BY SURVEY TAPE OR FENCING, IF REQUIRED, PRIOR TO CONSTRUCTION (SWDM APPENDIX D). DURING THE CONSTRUCTION PERIOD, NO DISTURBANCE BEYOND THE CLEARING LIMITS SHALL BE PERMITTED. THE CLEARING LIMITS SHALL BE MAINTAINED BY THE APPLICANT/ESC SUPERVISOR FOR THE DURATION OF CONSTRUCTION.
  - STABILIZED CONSTRUCTION ENTRANCES SHALL BE INSTALLED AT THE BEGINNING OF CONSTRUCTION AND MAINTAINED FOR THE DURATION OF THE PROJECT. ADDITIONAL MEASURES, SUCH AS CONSTRUCTED WHEEL WASH SYSTEMS OR WASH PADS, MAY BE REQUIRED TO ENSURE THAT ALL PAVED AREAS ARE KEPT CLEAN AND TRACK OUT TO ROAD RIGHT OF WAY DOES NOT OCCUR FOR THE DURATION OF THE PROJECT.
  - THE ESC FACILITIES SHOWN ON THIS PLAN MUST BE CONSTRUCTED PRIOR TO OR IN CONJUNCTION WITH ALL CLEARING AND GRADING SO AS TO ENSURE THAT THE TRANSPORT OF SEDIMENT TO SURFACE WATERS, DRAINAGE SYSTEMS, AND ADJACENT PROPERTIES IS MINIMIZED.
  - THE ESC FACILITIES SHOWN ON THIS PLAN ARE THE MINIMUM REQUIREMENTS FOR ANTICIPATED SITE CONDITIONS. DURING THE CONSTRUCTION PERIOD, THESE ESC FACILITIES SHALL BE UPGRADED AS NEEDED FOR UNEXPECTED STORM EVENTS AND MODIFIED TO ACCOUNT FOR CHANGING SITE CONDITIONS (E.G. ADDITIONAL COVER MEASURES, ADDITIONAL SUMP PUMPS, RELOCATION OF DITCHES AND SILT FENCES, PERIMETER PROTECTION ETC.) AS DIRECTED BY CITY OF MERCER ISLAND.
  - THE ESC FACILITIES SHALL BE INSPECTED DAILY BY THE APPLICANT/ESC SUPERVISOR AND MAINTAINED TO ENSURE CONTINUED PROPER FUNCTIONING. WRITTEN RECORDS SHALL BE KEPT OF WEEKLY REVIEWS OF THE ESC FACILITIES.
  - ANY AREAS OF EXPOSED SOILS, INCLUDING ROADWAY EMBANKMENTS, THAT WILL NOT BE DISTURBED FOR TWO CONSECUTIVE DAYS DURING THE WET SEASON OR SEVEN DAYS DURING THE DRY SEASON SHALL BE IMMEDIATELY STABILIZED WITH THE APPROVED ESC METHODS (E.G., SEEDING, MULCHING, PLASTIC COVERING, ETC.).
  - ANY AREA NEEDING ESC MEASURES THAT DO NOT REQUIRE IMMEDIATE ATTENTION SHALL BE ADDRESSED WITHIN SEVEN (7) DAYS.
  - THE ESC FACILITIES ON INACTIVE SITES SHALL BE INSPECTED AND MAINTAINED A MINIMUM OF ONCE A MONTH DURING THE DRY SEASON, BI-MONTHLY DURING THE WET SEASON, OR WITHIN TWENTY FOUR (24) HOURS FOLLOWING A STORM EVENT.
  - AT NO TIME SHALL MORE THAN ONE (1) FOOT OF SEDIMENT BE ALLOWED TO ACCUMULATE WITHIN A CATCH BASIN. ALL CATCH BASINS AND CONVEYANCE LINES SHALL BE CLEANED PRIOR TO PAVING. THE CLEANING OPERATION SHALL NOT FLUSH SEDIMENT-LADEN WATER INTO THE DOWNSTREAM SYSTEM.
  - ANY PERMANENT RETENTION/DETENTION FACILITY USED AS A TEMPORARY SETTLING BASIN SHALL BE MODIFIED WITH THE NECESSARY EROSION CONTROL MEASURES AND SHALL PROVIDE ADEQUATE STORAGE CAPACITY. IF THE FACILITY IS TO FUNCTION ULTIMATELY AS AN INFILTRATION SYSTEM, THE TEMPORARY FACILITY MUST BE ROUGH GRADED SO THAT THE BOTTOM AND SIDES ARE AT LEAST THREE FEET ABOVE THE FINAL GRADE OF THE PERMANENT FACILITY.
  - COVER MEASURES WILL BE APPLIED IN CONFORMANCE WITH APPENDIX D OF THE SURFACE WATER DESIGN MANUAL.
  - PRIOR TO THE BEGINNING OF THE WET SEASON (OCT. 1), ALL DISTURBED AREAS SHALL BE REVIEWED TO IDENTIFY WHICH ONES CAN BE SEEDED IN PREPARATION FOR THE WINTER RAINS. DISTURBED AREAS SHALL BE SEEDED WITHIN ONE WEEK OF THE BEGINNING OF THE WET SEASON.

**CITY NOTES**

- ANY CHANGES TO THE APPROVED PLANS REQUIRES CITY APPROVAL THROUGH A REVISION.
- APPLICANT IS RESPONSIBLE FOR ANY DAMAGES TO UNDERGROUND UTILITIES CAUSED FROM THIS CONSTRUCTION.
- CATCH BASIN FILTERS SHOULD BE PROVIDED FOR ALL STORM DRAIN CATCH BASINS/INLETS DOWNSLOPE AND WITHIN 500 FEET OF THE CONSTRUCTION AREA. CATCH BASIN FILTERS SHOULD BE DESIGNED BY THE MANUFACTURER FOR USE AT CONSTRUCTION SITES AND APPROVED BY THE CITY INSPECTOR. CATCH BASIN FILTERS SHOULD BE INSPECTED FREQUENTLY, ESPECIALLY AFTER STORM EVENTS. IF THE FILTER BECOMES CLOGGED, IT SHOULD BE CLEANED OR REPLACED.
- CONTRACTORS SHALL VERIFY LOCATIONS AND DEPTHS OF UTILITIES.
- AT LEAST 48 HOURS PRIOR TO CONSTRUCTION, CALL "ONE CALL" AT 1.800.424.5555
- DO NOT BACKFILL WITH NATIVE MATERIAL ON PUBLIC RIGHT-OF-WAY. ALL MATERIAL MUST BE IMPORTED
- EROSION CONTROL: ALL "LAND DISTURBING ACTIVITY" IS SUBJECT TO PROVISIONS OF MERCER ISLAND ORDINANCE 95C-118 "STORM WATER MANAGEMENT." SPECIFIC ITEMS TO BE FOLLOWED AT YOUR SITE:
- PROTECT ADJACENT PROPERTIES FROM ANY INCREASED RUNOFF OR SEDIMENTATION DUE TO THE CONSTRUCTION PROJECT THROUGH THE USE OF APPROPRIATE "BEST MANAGEMENT PRACTICES" (BMP) EXAMPLES INCLUDE, BUT ARE NOT LIMITED TO, SEDIMENT TRAPS, SEDIMENT PONDS, FILTER FABRIC FENCES, VEGETATIVE BUFFER STRIPS OR BIOENGINEERED SWALES.
- CONSTRUCTION ACCESS TO THE SITE SHOULD BE LIMITED TO ONE ROUTE. STABILIZE ENTRANCE WITH QUARRY SPALLS TO PREVENT SEDIMENT FROM LEAVING THE SITE OR ENTERING THE STORM DRAINS.
- PREVENT SEDIMENT, CONSTRUCTION DEBRIS, PAINTS, SOLVENTS, ETC., OR OTHER TYPES OF POLLUTION FROM ENTERING PUBLIC STORM DRAINS. KEEP ALL POLLUTION ON YOUR SITE.
- ALL EXPOSED SOILS SHALL REMAIN DENUDED FOR NO LONGER THAN SEVEN (7) DAYS AND SHALL BE STABILIZED WITH MULCH, HAY, OR THE APPROPRIATE GROUND COVER. ALL EXPOSED SOILS SHALL BE COVERED IMMEDIATELY DURING ANY RAIN EVENT.
- INSTALLATION OF CONCRETE DRIVEWAYS, TREES, SHRUBS, IRRIGATION, BOULDERS, BERMS, WALLS, GATES, AND OTHER IMPROVEMENTS ARE NOT ALLOWED IN THE PUBLIC RIGHT-OF-WAY WITHOUT PRIOR APPROVAL, AND AN ENCROACHMENT AGREEMENT AND RIGHT OF WAY PERMIT FROM THE SENIOR DEVELOPMENT ENGINEER.
- OWNER SHALL CONTROL DISCHARGE OF SURFACE DRAINAGE RUNOFF FROM EXISTING AND NEW IMPERVIOUS AREAS IN A RESPONSIBLE MANNER. CONSTRUCTION OF NEW GUTTERS AND DOWNSPOUTS, DRY WELLS, LEVEL SPREADERS OR DOWNSTREAM CONVEYANCE PIPE MAY BE NECESSARY TO MINIMIZE DRAINAGE IMPACT TO YOUR NEIGHBORS. CONSTRUCTION OF MINIMUM DRAINAGE IMPROVEMENTS SHOWN OR CALLED OUT ON THIS PLAN DOES NOT IMPLY RELIEF FROM CIVIL LIABILITY FOR YOUR DOWNSTREAM DRAINAGE.
- POT HOLING THE PUBLIC UTILITIES IS REQUIRED PRIOR TO ANY GRADING ACTIVITIES LESS THAN 6' OVER THE PUBLIC MAINS (WATER, SEWER AND STORM SYSTEMS). IF THERE IS A CONFLICT, THE APPLICANT IS REQUIRED TO SUBMIT A REVISION FOR APPROVAL PRIOR TO ANY GRADING ACTIVITIES OVER THE PUBLIC MAINS.
- REMEMBER: EROSION CONTROL IS YOUR FIRST INSPECTION.
- ROOF DRAINS MUST BE CONNECTED TO THE STORM DRAIN SYSTEM AND INSPECTED BY THE PUBLIC WORKS DEPARTMENT PRIOR TO ANY BACKFILLING OF PIPE.
- SILENT FENCE: CLEAN AND PROVIDE REGULAR MAINTENANCE OF THE SILT FENCE. THE FENCE IS TO REMAIN VERTICAL AND IS TO FUNCTION PROPERLY THROUGHOUT THE TERM OF THE PROJECT.
- WORK IN PUBLIC RIGHT OF WAY REQUIRES A RIGHT-OF-WAY USE PERMIT.
- REFER TO WATER SERVICE PERMIT FOR ACTUAL LOCATION OF NEW WATER METER AND SERVICE LINE DETERMINED BY MERCER ISLAND WATER DEPARTMENT.
- THE TV INSPECTION OF THE EXISTING SIDE SEWER TO THE CITY SEWER MAIN IS REQUIRED. IF THE RESULT OF THE TV INSPECTION IS NOT IN SATISFACTORY CONDITION, AS DETERMINED BY THE CITY OF MERCER ISLAND INSPECTOR, THE REPLACEMENT OF THE EXISTING SIDE SEWER IS REQUIRED. ALTERNATELY, A PRESSURE TEST OF THE SIDE SEWER, FROM SEWER MAIN TO POINT OF CONNECTION, MAY BE SUBSTITUTED FOR THE VIDEO INSPECTION.
- NEWLY INSTALLED SIDE SEWER REQUIRES A 4 P.S.I. AIR TEST OR PROVIDE 10' OF HYDROSTATIC HEAD TEST.
- POT HOLING THE PUBLIC UTILITIES IS REQUIRED PRIOR TO ANY GRADING ACTIVITIES LESS THAN 6' OVER THE PUBLIC MAINS (WATER, SEWER AND STORM SYSTEMS). IF THERE IS A CONFLICT, THE APPLICANT IS REQUIRED TO SUBMIT A REVISION FOR APPROVAL PRIOR TO ANY GRADING ACTIVITIES OVER THE PUBLIC MAINS.
- THE LIMITS AND EXTENDS OF THE PAVEMENT IN THE PUBLIC RIGHT OF WAY SHALL BE DETERMINED BY THE CITY ENGINEER PRIOR TO FINALIZE THE PROJECT.

**CONSTRUCTION ENTRANCE** **DOE**

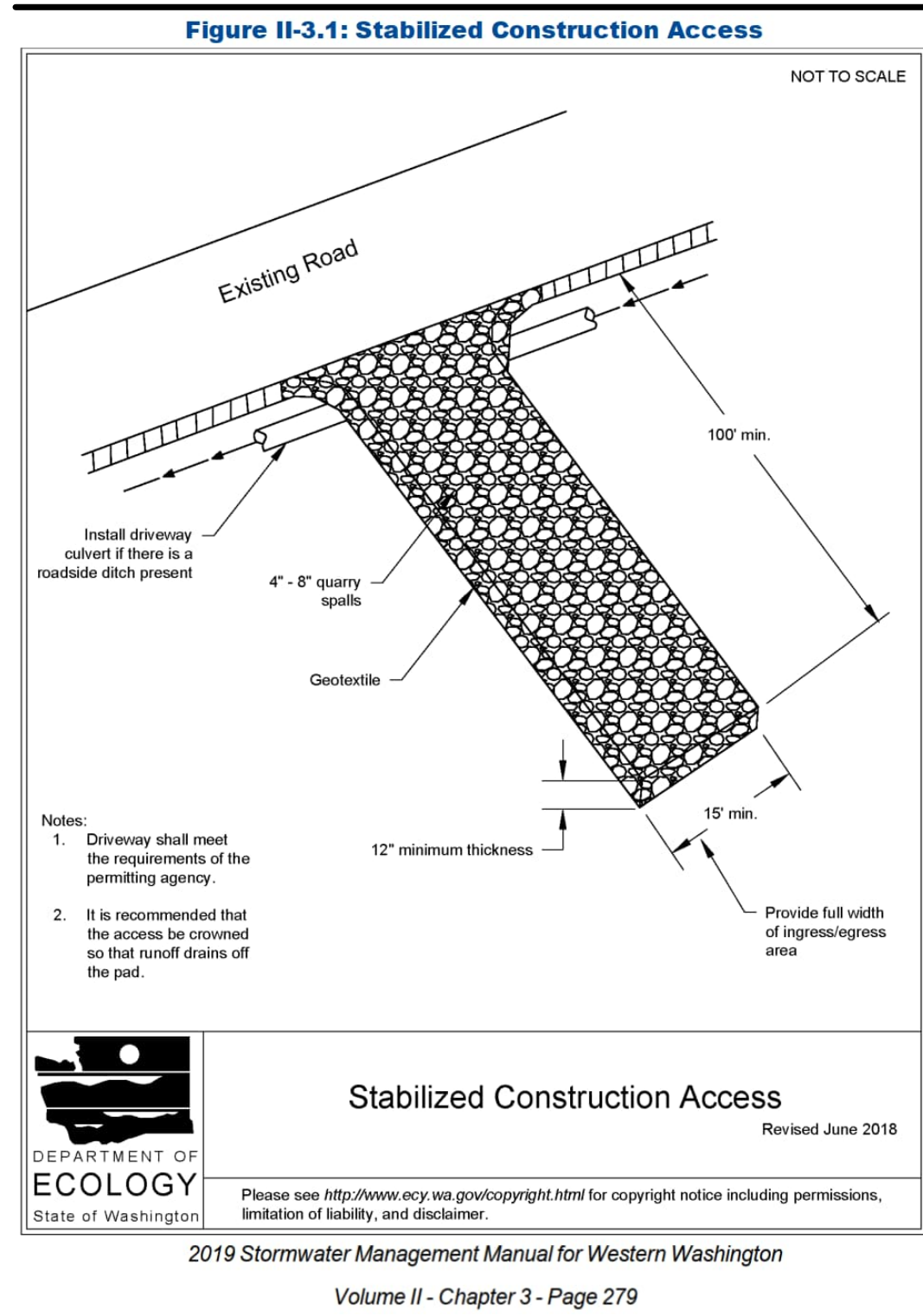

**TREE EVALUATION TABLE**

TREE EVALUATION DATA		MHI Custom Homes 472 - 7119 80th Ave. Mercer Island, WA											June 9, 2023		
Tree #	Location	Species	Dbh	CSD	Class	Structure	Health	Condition	CRZ radius	LOD II	LOD S	LOD E	LOD W	Grove	Status
1	On site	Pacific dogwood (Cornus nuttallii)	8"	14'	Significant	Good	Good	Good	8'	II/A	II/A	12'	II/A	Ilo	Retain
2	On site	Pacific dogwood (Cornus nuttallii)	6"	14'	Significant	Good	Good	Good	6'	II/A	II/A	12'	II/A	Ilo	Retain
3	On site	Pacific dogwood (Cornus nuttallii)	10"	18"	Significant	Good	Good	Good	10'	II/A	II/A	12'	II/A	Ilo	Retain
4	Off site	English holly (Ilex aquifolium)	6"	12'	Significant	Good	Good	Good	6'	II/A	II/A	12'	II/A	Ilo	II/A
5	On site	Portugal laurel (Prunus lusitanica)	6"	16'	Significant	Good	Good	Good	6'	II/A	II/A	12'	II/A	Ilo	Retain
6	On site	Douglas fir (Pseudotsuga menziesii)	22"	36'	Significant	Good	Good	Good	22'	II/A	II/A	14'	II/A	Ilo	Retain
7	On site	Pacific dogwood (Cornus nuttallii)	6"	16"	Significant	Good	Good	Good	6'	II/A	II/A	12'	II/A	Ilo	Retain
8	On site	Pacific dogwood (Cornus nuttallii)	12"	22'	Significant	Good	Good	Good	12'	II/A	II/A	16'	II/A	Ilo	Retain
9	On site	Pacific dogwood (Cornus nuttallii)	16"	32'	Significant	Good	Good	Good	16'	II/A	II/A	16'	II/A	Ilo	Retain
10	On site	Hawthorn (Crataegus sp.)	6"	14'	Significant	Good	Good	Good	6'	II/A	II/A	8'	II/A	Ilo	Retain
11	On site	Italian prune (Prunus domestica)	6"	14'	Significant	Good	Good	Good	6'	II/A	II/A	10'	II/A	Ilo	Retain
12	On site	Pacific dogwood (Cornus nuttallii)	10"	22'	Significant	Good	Good	Good	10'	II/A	II/A	16'	II/A	Ilo	Retain
13	On site	Douglas fir (Pseudotsuga menziesii)	18"	32'	Significant	Good	Good	Good	18'	II/A	II/A	16'	II/A	Ilo	Retain
14	On site	Douglas fir (Pseudotsuga menziesii)	24"	36'	Significant	Good	Good	Good	24'	II/A	II/A	16'	II/A	Ilo	Retain
15	On site	Japanese maple (Acer japonicum)	7"	16'	Significant	Good	Good	Good	7'	10'	II/A	II/A	II/A	Ilo	Retain
16	Off site	Pacific madrone (Arbutus menziesii)	22"	20'	II/A	Poor	Poor	Poor	22'	II/A	II/A	16'	II/A	Ilo	II/A
17	Off site	Douglas fir (Pseudotsuga menziesii)	18"	34'	Significant	Good	Good	Good	18'	II/A	II/A	16'	II/A	Ilo	II/A
18	Off site	Douglas fir (Pseudotsuga menziesii)	36"	44'	Exceptional	Good	Good	Good	36'	II/A	II/A	II/A	16'	Ilo	II/A
19	Off site	Douglas fir (Pseudotsuga menziesii)	28"	36'	Significant	Good	Good	Good	28'	II/A	II/A	II/A	16'	Ilo	II/A
20	Off site	Douglas fir (Pseudotsuga menziesii)	16"	32'	Significant	Good	Good	Good	16'	II/A	II/A	II/A	16'	Ilo	II/A
21	Off site	Douglas fir (Pseudotsuga menziesii)	28"	38'	Significant	Good	Good	Good	28'	II/A	II/A	II/A	16'	Ilo	II/A
22	Off site	Douglas fir (Pseudotsuga menziesii)	26"	40'	Significant	Good	Good	Good	26'	II/A	II/A	II/A	16'	Ilo	II/A
23	Off site	Douglas fir (Pseudotsuga menziesii)	26"	36'	Significant	Good	Good	Good	26'	II/A	II/A	II/A	16'	Ilo	II/A
24	Off site	Douglas fir (Pseudotsuga menziesii)	18"	36'	Significant	Good	Good	Good	18'	II/A	II/A	II/A	16'	Ilo	II/A
24	Off site	Douglas fir (Pseudotsuga menziesii)	22"	36'	Significant	Good	Good	Good	22'	II/A	II/A	II/A	16'	Ilo	II/A
25	Off site	Douglas fir (Pseudotsuga menziesii)	38"	44'	Exceptional	Good	Good	Good	38'	II/A	II/A	II/A	16'	Ilo	II/A

NO.	DATE	BY	REVISIONS

APPLICANT  
HOME PROJECT 472 LLC  
MN CUSTOM HOMES  
CONTACT: JACOB SOUTHARD  
3006 112th AVE NE, SUITE #100  
BELLEVUE, WA 98004  
PH: 425-429-6645  
permits@mcustom.com

DATE: Aug 22, 2023  
JOB# 0472  
DRAFTED: SS DESIGN: DE  
DIGITAL SIGNATURE

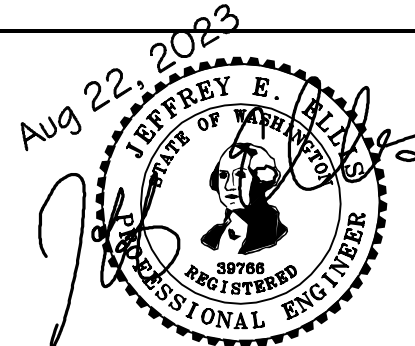

**CIVIL ENGINEERING SOLUTIONS**  
102 NW CANAL STREET SEATTLE, WA 98107  
PHONE: 206.930.0342 DUFFY@CESOLUTIONS.US

**TESC & CITY NOTES**  
**TESC DETAILS**  
HOME #472 by MN CUSTOM HOMES  
7119 80th AVENUE SE, MERCER ISLAND, WA 98040

#2308-116  
DRAWING NO: **C1.2**  
APN 915970-0050  
#2308-116







**MINIMUM 10% ORGANIC - COMPOST SOIL REQUIRED**

**SOIL AMENDMENT REQUIRED**

COMPOST AMENDED SOIL REQUIRED ON ALL LANDSCAPED AREAS AFTER CONSTRUCTION. SEE DETAIL BELOW.

**SOIL INSPECTION REQUIRED BY ENGINEER**

A POST CONSTRUCTION INSPECTION & CERTIFICATION OF AMENDED SOILS IS REQUIRED BY A LICENSED CIVIL ENGINEER. THIS IS REQUIRED BEFORE FINAL SIGN-OFF BY CITY.

**INFILTRATION TRENCH** (SOURCE: BELLEVUE)

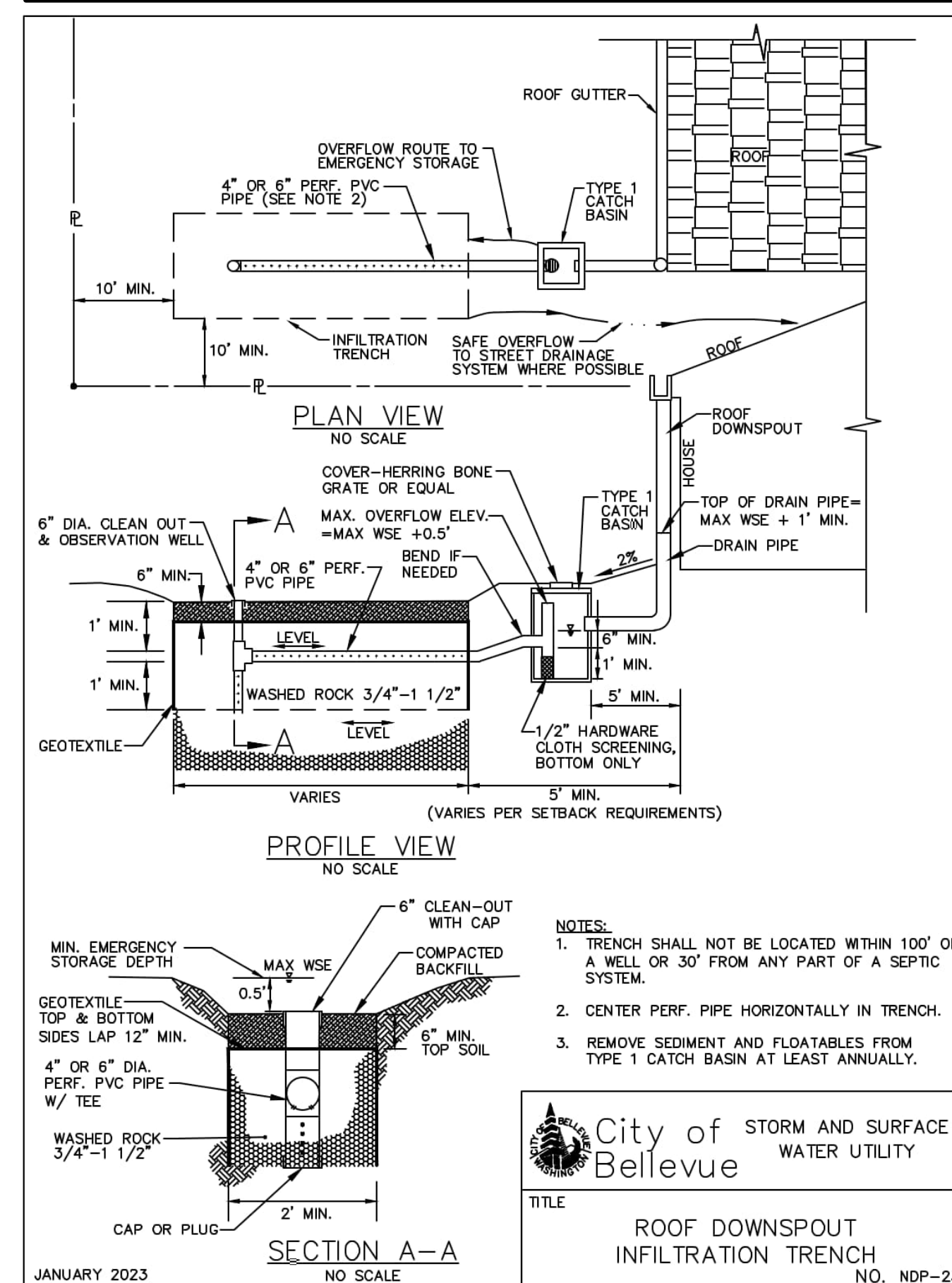

**COMPOST AMENDED SOIL SPEC** (SOURCE: BELLEVUE)

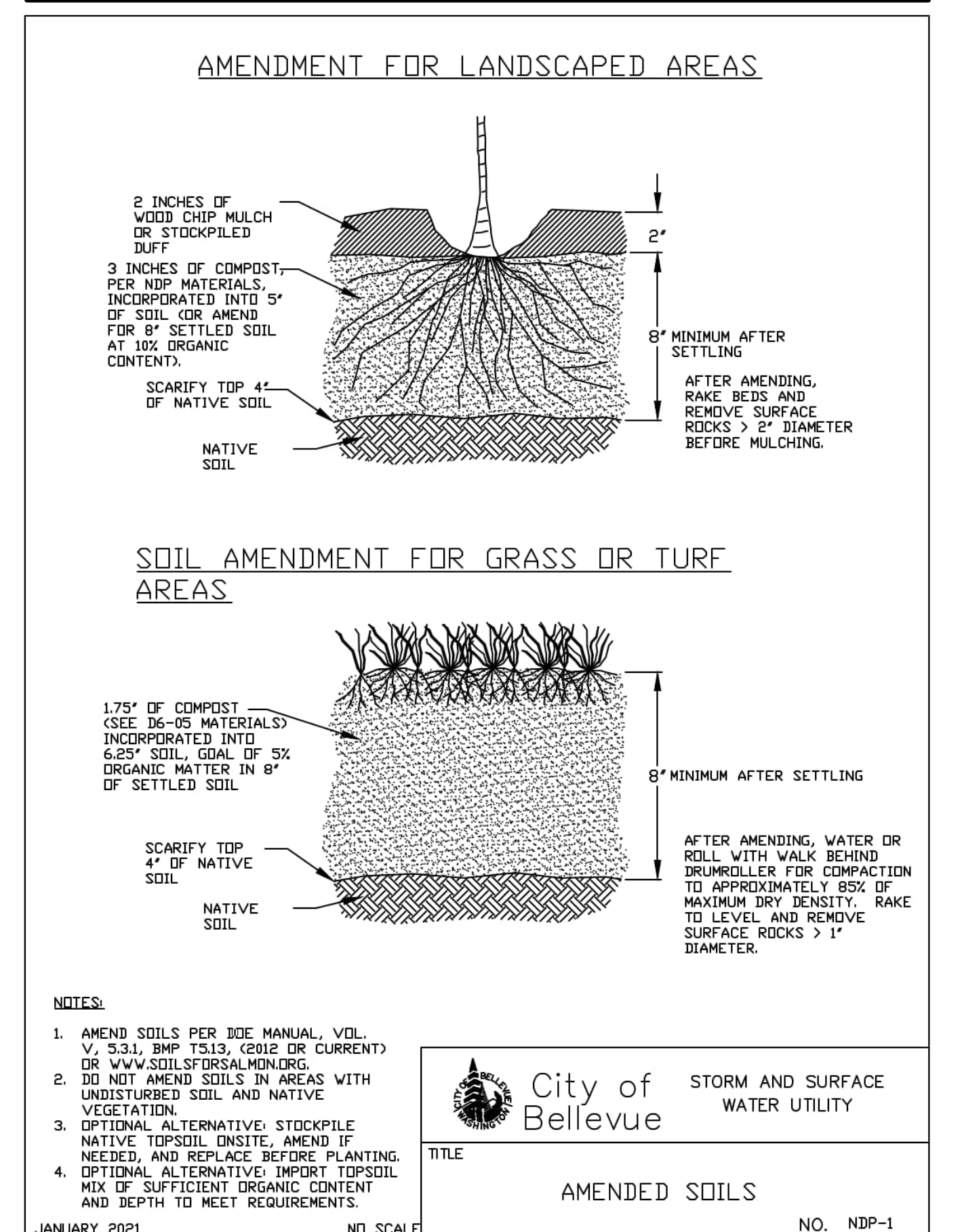

NO.	DATE	BY	REVISIONS

APPLICANT  
HOME PROJECT 472 LLC  
MN CUSTOM HOMES  
CONTACT: JACOB SOUTHARD  
3006 112th AVE NE, SUITE #100  
BELLEVUE, WA 98004  
PH: 425-429-6645  
permits@mncustom.com

DATE: Aug 22, 2023  
JOB# 0472  
DRAFTED: SS DESIGN: SS  
DIGITAL SIGNATURE

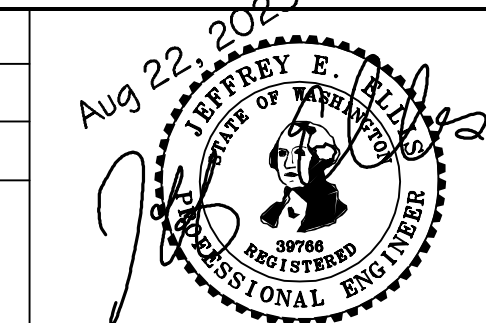

**CIVIL ENGINEERING SOLUTIONS**  
102 NW CANAL STREET SEATTLE, WA 98107  
PHONE: 206.930.0342 DUFFY@CESOLUTIONS.US

**STORM, BMP DETAILS**  
HOME #472 by MN CUSTOM HOMES  
7119 80th AVENUE SE, MERCER ISLAND, WA 98004

#2308-116  
DRAWING NO: **C3.5**  
APN 915970-0050  
#2308-116