

General Notes

CODES:

DESIGN IS IN ACCORDANCE WITH THE 2018 INTERNATIONAL RESIDENTIAL CODE (IRC) AS AMENDED BY THE LOCAL BUILDING DEPARTMENT.

FIRE (PRE-PERMIT FEEDBACK):

ALL NEW SINGLE FAMILY/ADU REQUIRE A MINIMUM OF A NFPA 13D SPRINKLER SYSTEM. AN EXTERIOR BELL IS REQUIRED TO BE INSTALLED AND MUST ACTIVATE UPON WATER FLOW. INTERIOR SMOKE DETECTORS OR SOUNDERS MUST ALSO BE INTERCONNECTED WITH THE WATER FLOW SWITCH.

FIRE ALARM (NFPA 72) MAY BE REQUIRED DUE TO ACCESS, GRADE, AND TRUNAROUND. THIS MAY BE A CODE ALTERNITIAVE.

VAPOR BARRIERS / GROUND COVERS:

AN APPROVED VAPOR BARRIER SHALL BE PROPERLY INSTALLED IN FLOOR DECKS, IN ENCLOSED RAFTER SPACES FORMED WHERE CEILINGS ARE APPLIED DIRECTLY TO THE UNDERSIDE OF ROOF RAFTERS, AND AT EXTERIOR WALLS INSETSTAPLED BATT WITH A PERM RATING LESS THAN ONE MAY BE INSTALLED IF THE VAPOR BARRIER IS TO THE WARM SIDE, STAPLES SHALL SE PLACED NOT MORE THAN 8-INCHES AND GAPS BETWEEN THE FACING AND THE FRAMING SHALL NOT EXCEED

A GROUND COVER OF 6 MIL (0006") BLACK POLYETHYLENE OF EQUIVALENT SHALL BE LAID OVER THE GROUND IN ALL CRAWL SPACES. THE GROUND COVER SHALL BE OVERLAPPED ONE FOOT AT EACH JOINT AND SHALL EXTEND TO THE FOUNDATION WALL.

LANDINGS AT DOORS:

R311.3 FLOORS AND LANDINGS AT EXTERIOR DOORS. THERE SHALL BE A LANDING OR FLOOR ON EACH SIDE OF EACH EXTERIOR DOOR. THE WIDTH OF EACH LANDING SHALL BE NOT LESS THAN THE DOOR SERVED. EVERY LANDING SHALL HAVE A DIMENSION OF NOT LESS THAN 36 INCHES MEASURED IN THE DIRECTION OF TRAVEL. THE SLOPE AT EXTERIOR LANDNGS SHALL NOT EXCEED UNIT VERTICAL IN 12 UNIT HORIZONTAL (2 PERCENT).

R312.1 GUARDS FALL PROTECTION:

R312.1.1 WHERE REQUIRED. GUARDS SHALL BE PROVIDED FOR THOSE PORTIONS OF OPEN-SIDED WALING SURFACES, INCLUDING STAIRS, RAMPS, AND LANDINGS, THAT ARE LOCATED MORE THAN 30 INCHES MEASURED VERTICALLY TO THE FLOOR OR GRADE BELOW AT ANY POINT WITHIN 36 INCHES HORIZONTALLY TO THE EDGE OF THE OPENING SIDE. INSECT SCREENING SHALL NOT BE CONSIDERED AS A GUARD.

R312.12 HEIGHT. REQUIRED GUARDS AT OPEN SIDED WALKING SURFACES, INCLUDING STAIRS, PORCHES, BALCONIES, OR LANDINGS, SHALL BE NOT LESS THAN 36 INCHES IN HEIGHT AS MEASURED VERTICALLY ABOVE THE ADJACENT WALKING SURFACE OR THE LINE CONNECTING THE NOSINGS.

R312.2 WINDOW FALL PROTECTION:

R3122.1 WINDOWSILLS. IN DUELLING UNITS. WHERE THE TOP OF THE SILL OF AN OPERABLE WINDOW OPENING IS LOCATED LESS THAN 24 INCHES ABOVE THE FINISHED FLOOR AND GREATER THAN 12 INCHES ABOVE THE FINISHED GRADE OR OTHER SURFACE BELOW ON THE EXTERIOR OF THE BUILDING, THE OPERABLE WINDOW SHALL COMPLY WITH ONE OF THE FOLLOWING:

1. OPERABLE WINDOWS WITH OPENINGS THAT WILL NOT ALLOW A 4 INCHES DIAMETER SPHERE TO PASS THROUGH THE OPENING WHERE THE OPENING IS IN ITS LARGEST OPENED POSITION.
2. OPERABLE WINDOWS THAT ARE PROVIDED WITH WINDOW FALL PREVENTION DEVICE THAT COMPLY WITH ASTM 2090

R314 SMOKE ALARMS:

R314.3 LOCATIONS. SMOKE ALARMS SHALL BE INSTALLED IN THE FOLLOWING LOCATIONS:

1. IN EACH SLEEPING ROOM
2. OUTSIDE EACH SEPARATE SLEEPING AREA IN THE IMMEDIATE VICINITY OF THE BEDROOMS.
1. 2. 3. ON EACH ADDITIONAL STYOY OF THE DWELLING, INCLUDING BASEMENT AND HABITABLE ATTICS. IN DWELLINGS, OR DWELLING UNITS WITH SPLIT LEVELS AND WITHOUT A INTERVENING DOOR BETWEEN THE ADJACENT LEVELS, A SMOKE ALARM INSTALLED ON THE UPPER LEVEL SHALL SUFFICE FOR THE ADJACENT LOWER LEVEL PROVIDED THAT LOWER LEVEL IS LESS THAN ONE FULL STORY BELOW THE UPPER LEVEL.
3. 4. SMOKE ALARMS SHALL BE INSTALLED NOT LESS THAN 3 FEET HORIZONTALLY FROM THE DOOR OR OPENING OF A BATHROOM THAT CONTAINS A BATHTUB OR SHOWER UNLESS THIS WOULD PREVENT PLACEMENT OF A SMOKE ALARM REQUIRED BY SECTION R314.3

R314.6 POWER SOURCE. SMOKE ALARMS SHALL RECEIVE THEIR PRIMARY POWER FROM THE BUILDING WIRING WHERE SUCH WIRING IS SERVED FROM A COMMERICAL SOURCE AND, WHERE PRIMARY POWER IS INTERRUPTED, SHALL RECEIVE POWER FROM A BATTERY. WIRING SHALL BE PERMANENT AND WITHOUT A DISCONNECTING SWITCH OTHER THAN THOSE REQUIRED FOR OVERCURRENT PROTECTION.

R314.5 COMBINATION ALARMS

COMBINATION SMOKE AND CARBON MONOXIDE ALARMS SHALL BE PERMITTED TO BE USED IN LIEU OF SMOKE ALARMS.

R315 CARBON MONOXIDE ALARMS:

R315.2.1 NEW CONSTRUCTION. FOR NEW CONSTRUCTION, CARBON MONOXIDE ALARMS SHALL BE PROVIDED IN DUELLING UNITS WHERE EITHER OR BOTH OF THE FOLLOWING CONDITION EXIST.

1. THE DWELLING UNIT CONTAINS A FUEL FIRED APPLIANCE.
2. THE DWELLING UNIT 14,45 AN ATTACHED GARAGE WITH AN OPENING THAT COMMUNICATES WITH THE DUELLING UNIT.

R315.5 INTERCONNECTIVITY:

WHERE MORE THAN ONE CARBON MONOXIDE ALARM IS REQUIRED TO BE INSTALLED WITHIN AN INDIVIDUAL DWELLING UNIT IN ACCORDANCE WITH SECTION R315.3, THE ALARM DEVICES SHALL BE INTERCONNECTED IN SUCH A MANNER THAT THE ACTUATION OF ONE ALARM WILL ACTIVATE ALL OF THE ALARMS IN THE DWELLING UNIT. PHYSICAL INTERCONNECTION OF THE CARBON MONOXIED ALARMS SHALL NOT BE REQUIRED WHERE LISTED WIRELESS ALARMS ARE INSTALLED AND ALL ALARMS SOUND UPON ACTIVATION OF ONE ALARM.

R315.6 POWER SOURCE. CARBON MONOXIDE ALARMS SHALL RECEIVE THEIR PRIMARY POWER FROM THE BUILDING WIRING WHERE SUCH WIRING IS SERVED FROM A COMMERCIAL SOURCE AND, WHERE PRIMARY POWER IS INTERRUPTED, SHALL RECEIVE POWER FROM A BATTERY. WIRING SHALL BE PERMANENT AND WITHOUT A DISCONNECTIGNG SWITCH OTHER THAN THOSE REQUIRED FOR OVERCURRENT PROTECTION.

R310 EMERGENCY ESCAPE AND RESCUE OPENINGS:

R310.1 EMERGENCY ESCAPE AND RESCUE OPENING REQUIRED.

BASEMENT, HABITABLE ATTICS AND EVERY SLEEPING ROOM SHALL HAVE NOT LESS THAN ONE OPERABLE EMERGENCY ESCAPE AND RESCUE OPENING. WHERE BASEMENTS CONTAIN ONE OR MORE SLEEPING ROOMS, AN EMERGENCY ESCAPE AND RESCUE OPENING SHALL BE REQUIRED IN EACH SLEEPING ROOM. EMERGENCY ESCAPE AND RESCUE OPENINGS SHALL OPEN DIRECTLY INTO A PUBLIC WAY, OR TO A YARD OR COURT THAT OPENS TO A PUBLIC WAY.

R310.2.1 MINIMUM OPENING AREA. EMERGENCY AND ESCAPE RESCUE OPENING SHALL HAVE A NET CLEAR OPENING OF NOT LESS THAN 5.7 SQUARE FEET. THE NET CLEAR OPENING DIMENSIONS REQUIRED BY THIS SECTION SHALL BE OBTAINED BY THE NORMAL OPERATION OF THE EMERGENCY ESCAPE AND RESCUE OPENING FROM THE INSIDE. THE NET CLEAR HEIGHT OPENING SHALL BE NOT LESS THAN 24 INCHES AND THE NET CLEAR WIDTH SHALL BE NOT LESS THAN 20 INCHES.

R310.2.2 WINDOW SILL HEIGHT. WHERE A WINDOW IS PROVIDED AS THE EMERGENCY ESCAPE AND RESCUE OPENING, IT SHALL HAVE A SILL HEIGHT OF NOT MORE THAN 44 INCHES ABOVE THE FLOOR.

R310.2.3 WINDOW WELLS. THE HORIZONTAL AREA OF THE WINDOW WELL SHALL BE NOT LESS THAN 9 SQUARE FEET, WITH THE HORIZONTAL PROJECTION AND WIDTH OF NOT LESS THAN 36 INCHES. THE AREA OF THE WINDOW WELL SHALL ALLOW THE EMERGENCY ESCAPE AND RESCUE OPENING TO BE FULLY OPENED.

R311 MEANS OF EGRESS:

R311.2 EGRESS DOOR - NOT LESS THAN ONE EGRESS DOOR SHALL BE PROVIDED FOR EACH DUELLING UNIT. THE EGRESS DOOR SHALL BE SIDE-HINGED, AND SHALL PROVIDE A CLEAR WIDTH OF NOT LESS THAN 32 INCHES WHERE MEASURED BETWEEN THE FACE OF THE DOOR AND THE STOP, WITH THE DOOR OPEN 90 DEGREES. THE CLEAR HEIGHT OF THE DOOR OPENING SHALL BE NOT LESS THAN 18 INCHES IN HEIGHT MEASURED FROM THE TOP OF THE THRESHOLD TO THE BOTTOM OF THE STOP.

R325 MEZZANINES:

R325.2 THE CLEAR HEIGHT ABOVE AND BELOW MEZZANINE FLOOR CONSTRUCTION SHALL BE NOT LESS THAN 1 FEET.

R325.5 MEZZANINES SHALL BE OPEN AND NOT OBSTRUCTED TO THE ROOM IN WHICH THEY ARE LOCATED EXCEPT FOR WALLS NOT MORE THAN 42 INCHES IN HEIGHT, COLUMNS, AND POSTS.

R311.6 HALLWAYS:

THE WIDTH OF HALLWAYS SHALL BE NOT LESS THAN 3 FEET.

M1502.4 CLOTHES DRYER:

DRYER EXHAUST DUCTS SHALL CONFORM TO THE REQUIREMENT SECTION M1502.4.1 THROUGH M1502.4.1

R302.5 DWELLING-GARAGE OPENING AND PENETRATION PROTECTION

R302.5.1 OPENINGS FROM A PRIVATE GARAGE DIRECTLY INTO A ROOM USED FOR SLEEPING PURPOSE SHALL NOT BE PERMITTED. OTHER OPENINGS BETWEEN THE GARAGE AND RESIDENCE SHALL BE EQUIPPED WITH SOLID WOOD DOORS NOT LESS THAN 1 3/8 INCHES IN THICKNESS, SOLID OR HONEYCOMB-CORE STEEL DOORS NOT LESS THAN 1 3/8 THICK, OR 20 MINUTE FIRE RATED DOOR, EQUIPPED WITH A SELF-CLOSING OR AUTOMATIC-CLOSING DEVICE.

R302.5.2 DUCT PENETRATION. DUCTS IN THE GARAGE AND DUCTS PENETRATING THE WALLS OR CEILINGS SEPARATING THE DWELLING FROM THE GARAGE SHALL BE CONSTRUCTED OF A MINIMUM NO. 26 GAGE SHEET STEEL OR OTHER APPROVED MATERIAL AND SHALL NOT HAVE OPENING INTO THE GARAGE.

SEPERATION FROM THE RESIDENCE AND THE ATTICS - NOT LESS THAN 1/2 INCH GYPSUM BOARD OR EQUIVALENT APPLIED TO THE GARAGE SIDE

SEPERATION FROM HABITABLE ROOMS ABOVE THE GARAGE - NOT LESS THAN 5/8 INCH TYPE X GYPSUM BOARD OR EQUIVELANT

SEPERATION FROM STRUCTURE(S) SUPPORTING FLOOR/CEILING ASSEMBLIES USED FOR SEPERATION REQUIRED BY THIS SECTION - NOT LESS THAN 1/2 INC GYPSUM BOARD OR EQUIVELANT

GARAGES LOCATED LESS THAN 3 FEET FROM A DWELLING UINT ON THE SAME LOT - NOT LESS THAN 1/2 INC GYPSUM BOARD OR EQUIVALENT APPLIED TO THE INTERIOR SIDE OF EXTERIOR WALLS THAT ARE WITHIN THIS AREA

R311.7 STAIRWAYS:

R311.1.8 HANDRAILS:

HANDRAILS SHALL BE PROVIDED ON NOT LESS THAN ONE SIDE OF EACH CONTINUOUS RN OF TREADS OR FLIGHT WITH FOUR OR MORE RISERS.

R311.7.8.1 HANDRAIL HEIGHT MEASURED VERTICALLY FROM THE SLOPED PLANE ADJOINING THE TREAD NOSING, OR FINISH SURFACE OF RAMP SLOPE, SHALL BE NOT LESS THAN 34 INCHES AND NOT MORE THAN 38 INCHES.

R311.7.82 CONTINUITY. HANDRAILS FOR STAIRWAYS SHALL BE CONTINUOUS FOR THE FULL LENGTH OF THE FLIGHT, FROM A POINT DIRECTLY ABOVE THE TOP RISER OF THE FLIGHT TO A POINT DIRECTLY ABOVE THE LOWEST RISER OF THE FLIGHT. HANDRAIL ENDS SHALL BE RETURNED OR SHALL TERMINATE IN NEWEL POSTS OR SAFETY TERMINALS. HANDRAILS ADJACENT TO A WALL SHALL HAVE A SPACE OF NOT LESS THAN 1.5 INCHES BETWEEN THE WALL AND THE HANDRAILS.

R311.7.1 STAIR WIDTH:

STAIRWAYS SHALL NOT BE LESS THAN 36 INCHES IN CLEAR WIDTH AT ALL POINTS ABOVE THE PERMITTED HANDRAIL HEIGHT AND BELOW THE REQUIRED HEADROOM HEIGHT. THE CLEAR WIDTH OF STAIRWAYS AT AND BELOW THE HANDRAIL HEIGHT, INCLUDING TREADS AND LANDINGS, SHALL NOT BE LESS THAN 31-1/2" WHERE THE HANDRAIL IS INSTALLED ON ONE SIDE AND 21" WHERE HANDRAILS ARE INSTALLED ON BOTHE SIDES.

R311.7.5.1 RISERS:

THE RISER HEIGHT SHALL BE NOT MORE THAN 7 3/4 INCHES. THE RISER TO BE MEASURED VERTICALLY BETWEEN LEADING EDGES OF THE ADJACENT TREADS. THE GREATEST RISER HEIGHT WITHIN ANY FLIGHT OF STAIRS SHALL NOT EXCEED THE SMALLEST BY MORE THAN 3/8 INCH.

OPEN RISERS ARE PERMITTED PROVIDED THAT THE OPENING LOCATE MORE THAN 30 INCHES, AS MEASURED VERTICALLY, TO THE FLOOR OR GRADE BELOW DO NOT PERMIT THE PASSAGE OF 4 INCHES DIAMETER SPHERE.

R311.7.5.2 TREADS:

THE TREAD DEPTH SHALL BE NOT LESS THAN 10 INCHES. THE TREAD DEPTH SHALL BE MEASURED HORIZONTALLY BETWEEN THE VERTICAL PLANES OF THE FOREMOST PROJECTION OF ADJACENT TREADS AND AT A RIGHT ANGLE TO THE TREAD'S LEADING EDGE. THE GREATEST TREAD DEPTH WITHIN ANY FLIGHT OF STAIRS SHALL NOT EXCEED THE SMALLEST BY MORE THAN 3/8 INCH

R311.7.9 ILLUMINATION:

STAIRWAYS SHALL BE PROVIDED WITH ILLUMINATION IN ACCORDANCE WITH SECTION R303.7

R308-SAFETY GLAZING:

R308.4 HAZARDOUS LOCATIONS. THE LOCATIONS SPECIFIED IN SECTIONS R308.4.1 TO R308.4.7 SHALL BE CONSIDERED TO BE SPECIFIC HAZARDOUS LOCATIONS FOR THE PURPOSE OF GLAZING.

R308.4.1 GLAZING IN DOORS. GLAZING IN FIXED AND OPERABLE PANELS OF SWINGING, SLIDING, AND BIFOLD DOORS SHALL BE CONSIDERED TO BE A HAZARDOUS LOCATION.

R308.4.2 GLAZING ADJACENT TO DOORS. GLAZING IN AN INDIVIDUAL FIXED OR OPERABLE PANEL ADJACENT TO A DOOR SHALL BE CONSIDERED A HAZARDOUS LOCATION WHERE THE BOTTOM EXPOSED EDGE OF THE GLAZING IS LESS THAN 60 INCHES ABOVE THE FLOOR OR WALKING SURFACE AND IT MEETS EITHER OF THE FOLLOWING CONDITIONS:

1. WHERE THE GLAZING IS WITHIN 24 INCHES OF EITHER SIDE OF THE DOOR IN THE PLANE OF THE DOOR IN A CLOSED POSITON.

2. WHERE THE GLAZING IS ON A WALL LESS THAN 180 DEGREES FROM THE PLANDE OF THE DOOR IN A CLOSED POSITION AND WITHIN 24 INCHES OF THE HINGE SIDE OF AN IN-SWINGING DOOR

R308.4.3 GLAZING IN WINDOWS. GLAZING IN AN INDIVIDUAL FIXED OR OPERABLE PANEL THAT MEETS ALL OF THE FOLLOWING CONDITIONS SHALL BE CONSIDERED TO BE A HAZARDOUS LOCATION:

1. THE EXPOSED AREA OF AN INDIVIDUAL PANE IS LARGER THAN 9 SQUARE FEET

2. THE BOTTOM EDGE OF THE GLAZING IS LESS THAN 18 INCHES ABOVE THE FLOOR

3. THE TOP EDGE OF THE GLAZING IS MORE THAN 36 INCHES ABOVE THE FLOOR

4. ONE OR MORE WALKING SURFACES ARE WITHIN 36 INCHES, MEASURED HORIZONTALLY AND IN A STRAIGHT LINE, OF THE GLAZING

R308.4.5 GLAZING AND WET SURFACES. GLAZING IN WALLS, ENCLOSURES OR FENCES CONTAINING OR FACING HOT TUBS, SPAS, WHIRLPOOLS, SAUNAS, STEM ROOMS, BATHTUBS, SHOWERS AND INDOOR OR OUTDOOR SWIMMING POOLS WHERE THE BOTTOM EXPOSED EDGE OF THE GLAZING IS LESS THAN 60 INCHES MEASURED VERTICALLY ABOVE ANY STANDING OR WALKING SURFACE SHALL BE CONSIDERED TO BE A HAZARDOUS LOCATION. THIS SHALL APPLY TO SINGLE GLAZING AND EACH PANE IN MULTIPLE GLAZING.

R308.4.6 GLAZING ADJACENT TO STAIRS AND RAMPS. GLAZING WHERE THE BOTTOM EXPOSED EDGE OF THE GLAZING IS LESS THAN 36 INCHES ABOVE THE PLANE OF THE ADJACENT WALKING SURFACES OF STAIRWAYS, LANDINGS, BETWEEN FLIGHTS OF STAIRS AND RAMPS SHALL BE CONSIDERED TO BE A HAZARDOUS LOCATION

R308.4.7 GLAZING ADJACENT TO THE BOTTOM STAIR LANDING AT THE BOTTOM OF THE STAIRWAY WHEN THE GLAZING IS LESS THAN 36 INCHES ABOVE THE LANDING AND WITHIN A 60 INCHES HORIZONTAL ARCH LESS THAN 180 DEGREES FROM THE BOTTOM TREAD NOSING SHALL BE CONSIDERED TO BE A HAZARDOUS LOCATION.

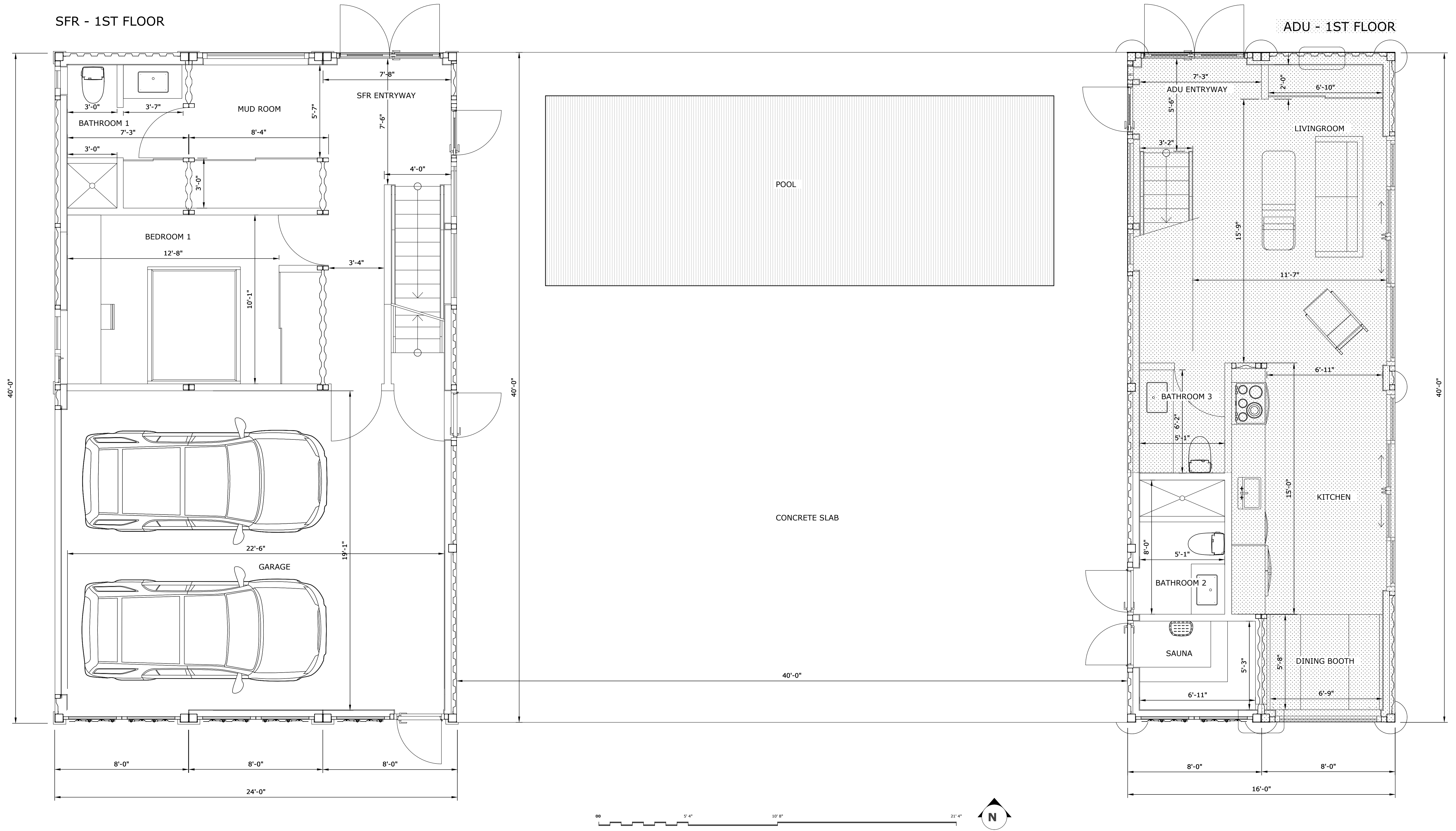

SFR - 2ND FLOOR

ADU - 1ST FLOOR

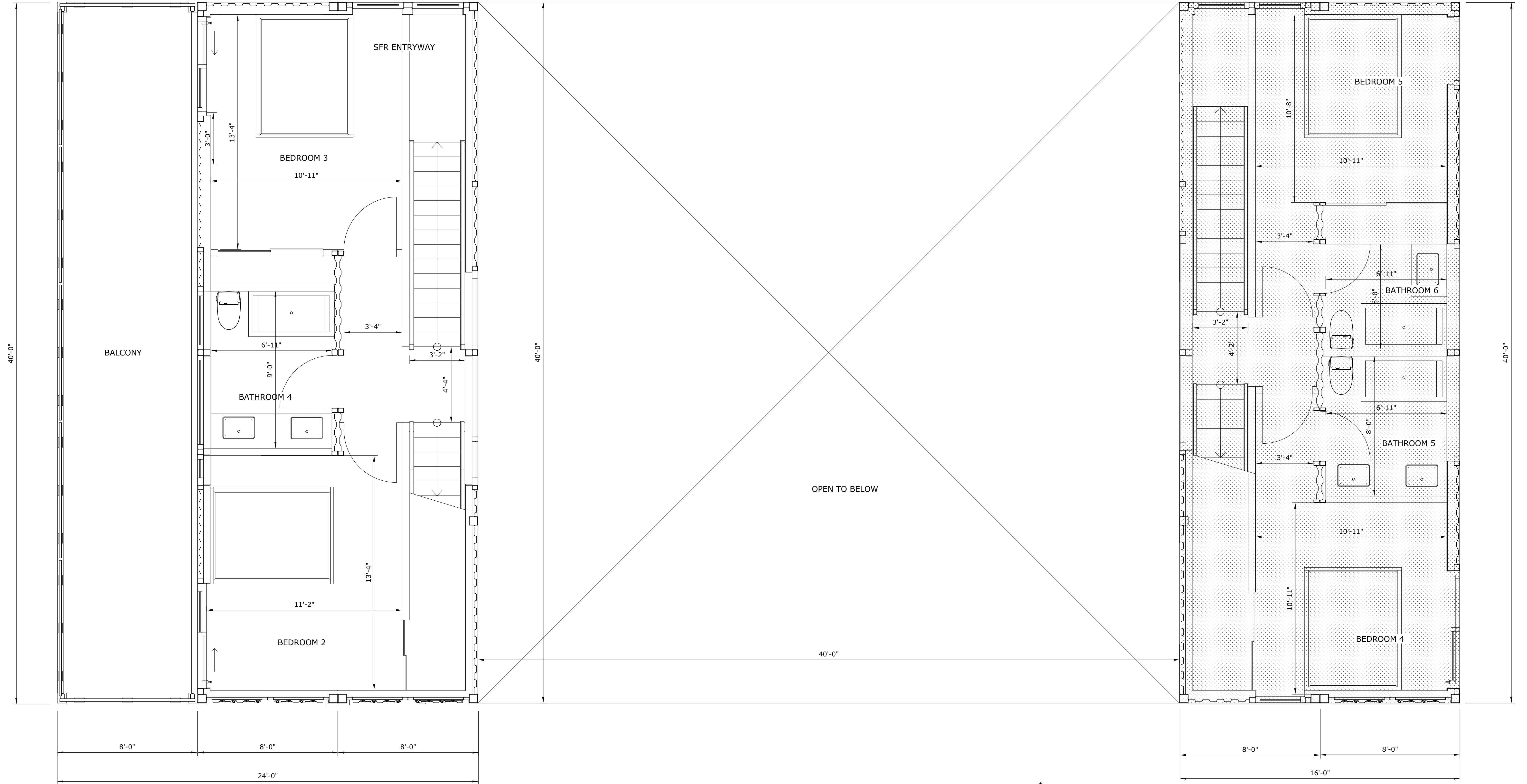

SFR - 3RD FLOOR

ADU - 3RD FLOOR

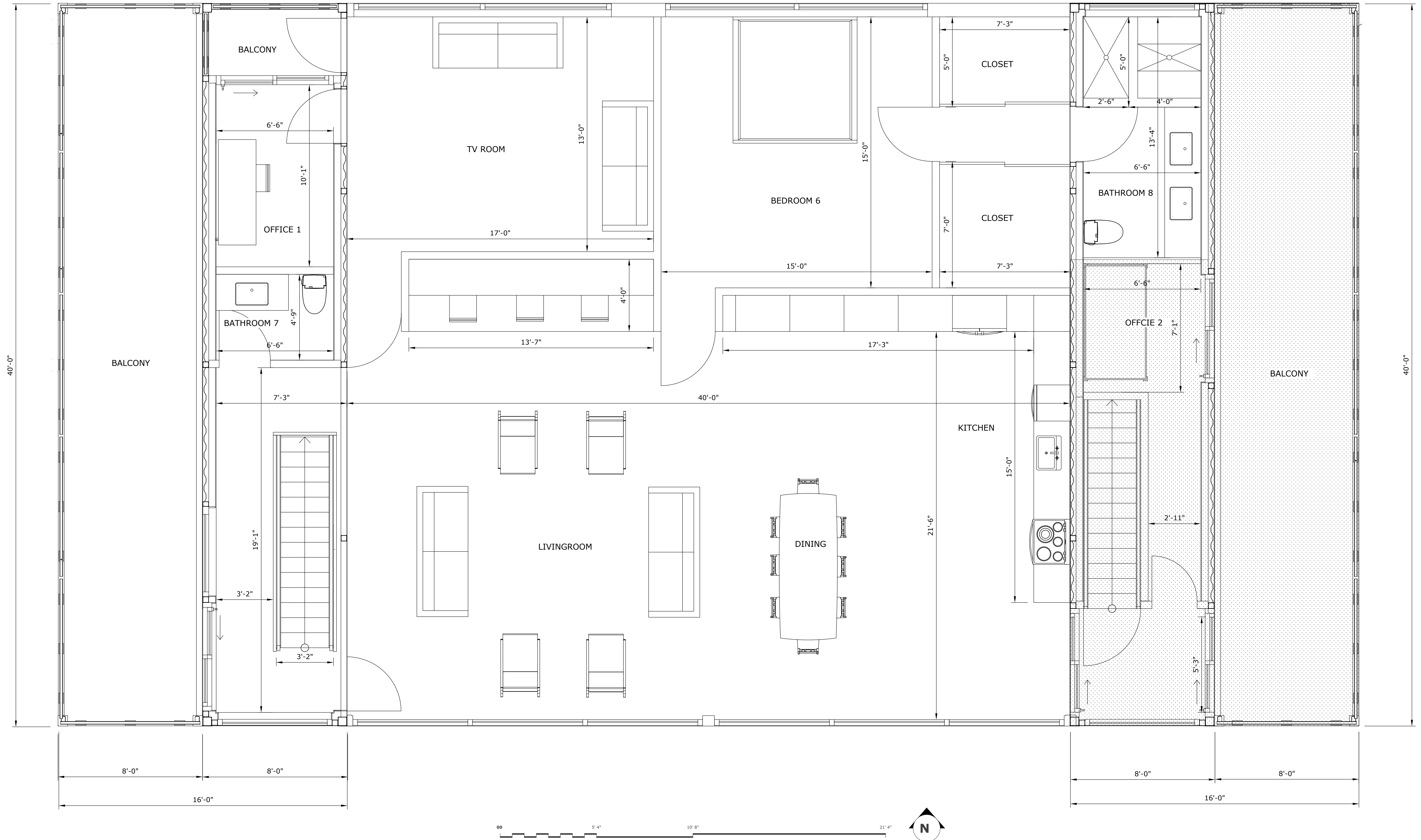

SFR - BASEMENT

REFER TO THE STRUCTURAL PACKAGE FOR FOUNDATION DESIGNS

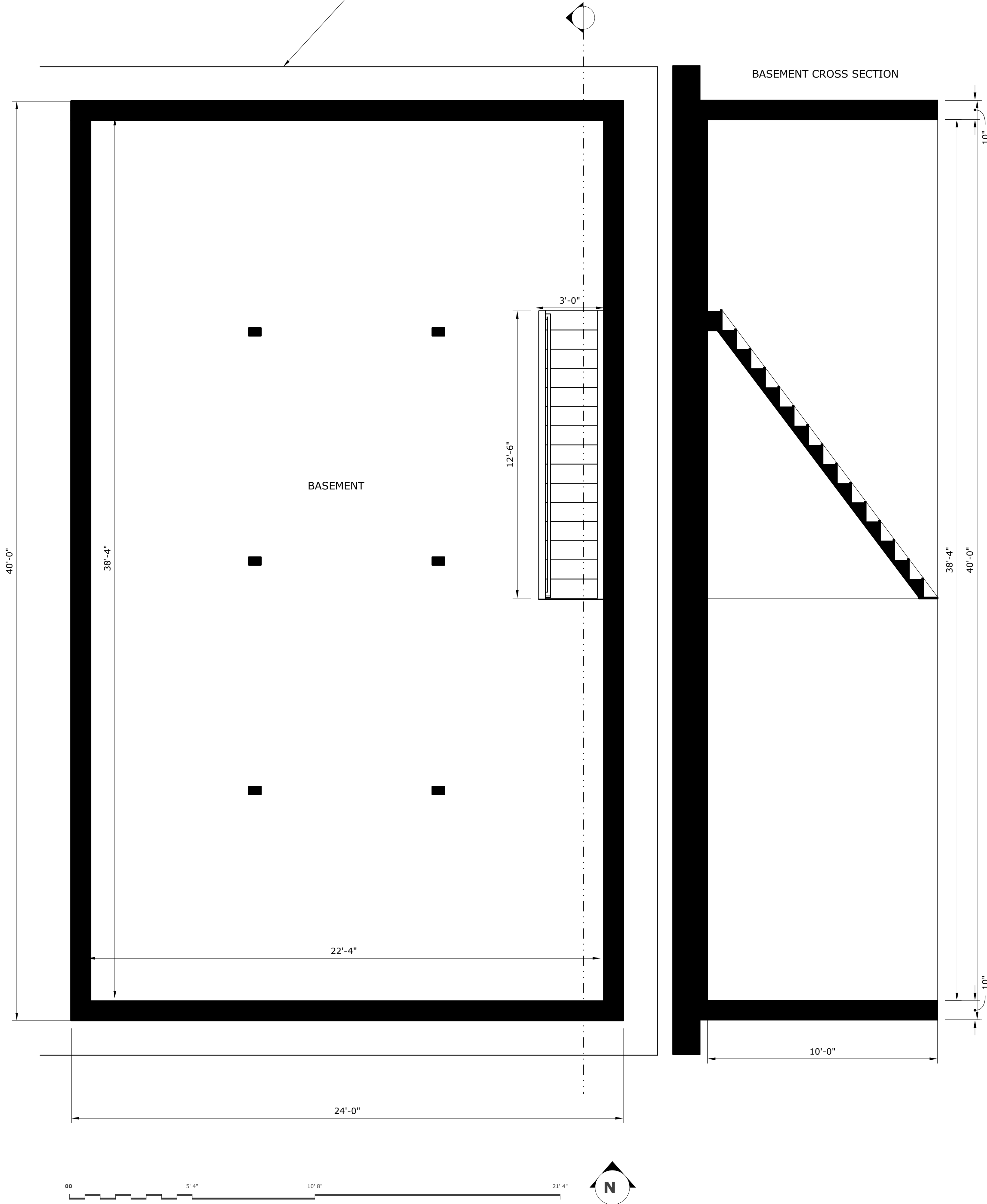

STAIR DESIGN
(USED FOR ALL FLOORS)

NOTES:
 This house contains 5 sets of staircases: 2 on the west side, 2 on the east side in the structure, and one set leading to the basement. All 4 of the above grade staircases have the same design and dimensions. The basement stairs is also the same design except it gets one extra riser. The handrail side of the stairs is always opposite the exterior wall, so the staircase design depicted on this sheet would be the design for the west stair stack. In the east stack, the stairs are exactly the same, except mirrored.

STAIR CODE SUMMARY: IRC 2018 - Section R311.7
 REQUIREMENTS VS ACTUAL:

	IRC2018 Requirement	Actual
Width	36", 31.5" (one handrail) (min)	38", 34.5" (one handrail)
Headroom	6' 8" (min)	8' 10.5"
Vertical Rise	12' 7" (max)	9.5"
Riser Height	7.75" (max)	7.6"
Tread Depth	10"	10"
Nosing Projection	0.75" - 1.25"	0.75"
Landings	3' (min)	All more than 3'
Handrail Sides	1 (min)	1
Handrail Height	34" - 38"	36"
Handrail Projection	4.5" (max)	3.5"
Handrail Wall Gap	1.5" (min)	1.5"
Handrail Grip Size	4" - 6" perimeter	4" perimeter

R311.7 Stairways.
R311.7.1 Width. Stairways shall be not less than 36 inches (914 mm) in clear width at all points above the permitted handrail height and below the required headroom height. The clear width of stairways at and below the handrail height, including treads and landings, shall be not less than 31 1/2 inches (787 mm) where a handrail is installed on one side and 27 inches (698 mm) where handrails are installed on both sides.
R311.7.2 Headroom. The headroom in stairways shall be not less than 6 feet 8 inches (2032 mm) measured vertically from the sloped line adjoining the tread nosing or from the floor surface of the landing or platform on that portion of the stairway.
R311.7.3 Vertical rise. A flight of stairs shall not have a vertical rise larger than 151 inches (3835 mm) between floor levels or landings.
R311.7.5.1 Risers. The riser height shall be not more than 7 3/4 inches (196 mm). The riser shall be measured vertically between leading edges of the adjacent treads. The greatest riser height within any flight of stairs shall not exceed the smallest by more than 3/8 inch (9.5 mm). Risers shall be vertical or sloped from the underside of the nosing of the tread above at an angle not more than 30 degrees (0.51 rad) from the vertical. At open risers, openings located more than 30 inches (762 mm), as measured vertically, to the floor or grade below shall not permit the passage of a 4-inch-diameter (102 mm) sphere.
R311.7.5.2 Treads. The tread depth shall be not less than 10 inches (254 mm). The tread depth shall be measured horizontally between the vertical planes of the foremost projection of adjacent treads and at a right angle to the tread's leading edge. The greatest tread depth within any flight of stairs shall not exceed the smallest by more than 3/8 inch (9.5 mm).
R311.7.5.3 Nosings. Nosings at treads, landings and floors of stairways shall have a radius of curvature at the nosing not greater than 9/16 inch (14 mm) or a bevel not greater than 1/2 inch (12.7 mm). A nosing projection not less than 3/4 inch (19 mm) and not more than 1 1/4 inches (32 mm) shall be provided on stairways. The greatest nosing projection shall not exceed the smallest nosing projection by more than 3/8 inch (9.5 mm) within a stairway.
R311.7.6 Landings for stairways. There shall be a floor or landing at the top and bottom of each stairway. The width perpendicular to the direction of travel shall be not less than the width of the flight served. For landings of shapes other than square or rectangular, the depth at the walk line and the total area shall be not less than that of a quarter circle with a radius equal to the required landing width. Where the stairway has a straight run, the depth in the direction of travel shall be not less than 36 inches (914 mm).
R311.7.8 Handrails. Handrails shall be provided on not less than one side of each flight of stairs with four or more risers.
R311.7.8.1 Height. Handrail height, measured vertically from the sloped plane adjoining the tread nosing, or finish surface of ramp slope, shall be not less than 34 inches (864 mm) and not more than 38 inches (965 mm).
R311.7.8.2 Handrail projection. Handrails shall not project more than 4 1/2 inches (114 mm) on either side of the stairway.
R311.7.8.3 Handrail clearance. Handrails adjacent to a wall shall have a space of not less than 1 1/2 inches (38 mm) between the wall and the handrails.
R311.7.8.4 Continuity. Handrails shall be continuous for the full length of the flight, from a point directly above the top riser of the flight to a point directly above the lowest riser of the flight. Handrail ends shall be returned or shall terminate in newel posts or safety terminals.
R311.7.8.5 Grip size. Required handrails shall be of one of the following types or provide equivalent graspability. Type 1. Handrails with a circular cross section shall have an outside diameter of not less than 1 1/4 inches (32 mm) and not greater than 2 inches (51 mm). If the handrail is not circular, it shall have a perimeter of not less than 4 inches (102 mm) and not greater than 6 1/4 inches (160 mm) and a cross section of not less than 2 1/4 inches (57 mm). Edges shall have a radius of not less than 0.01 inch (0.25 mm).

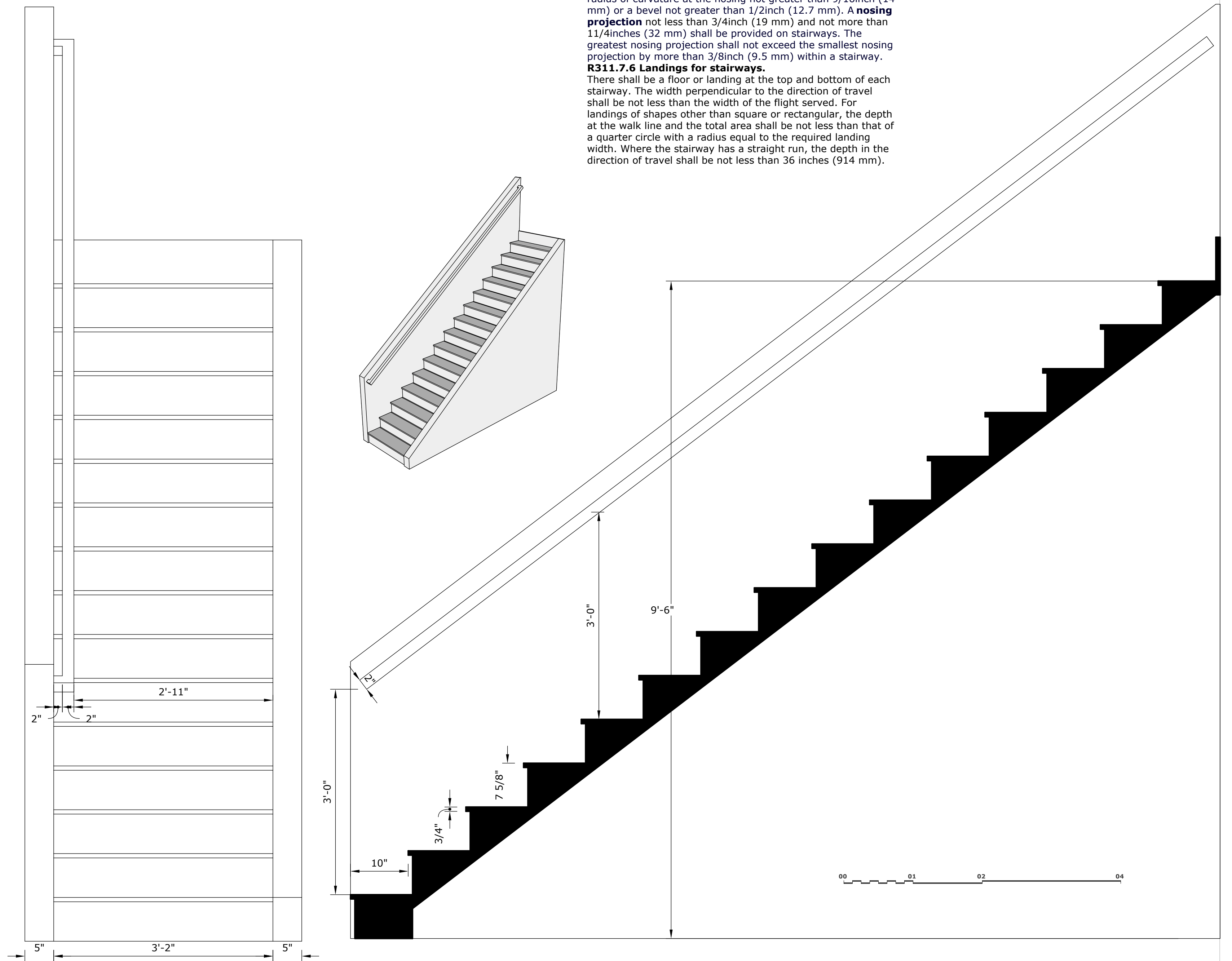

Elevations - Front & Back

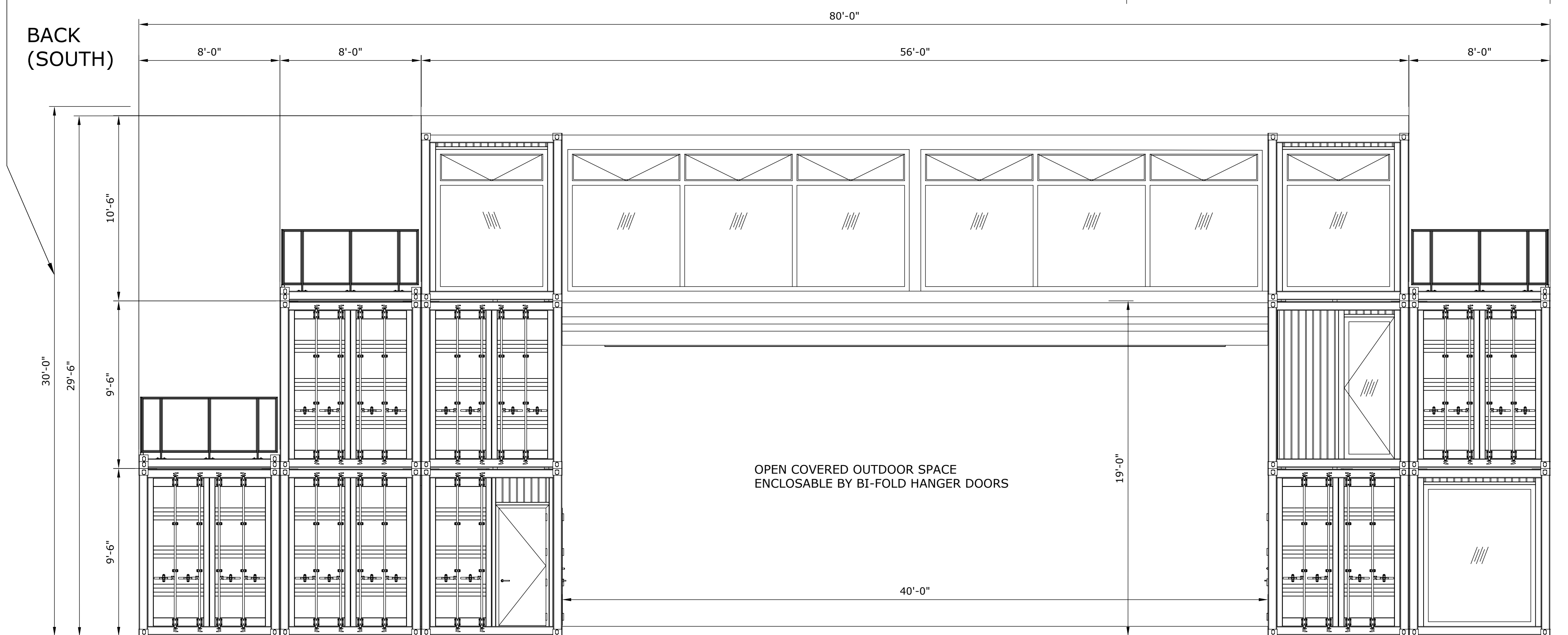
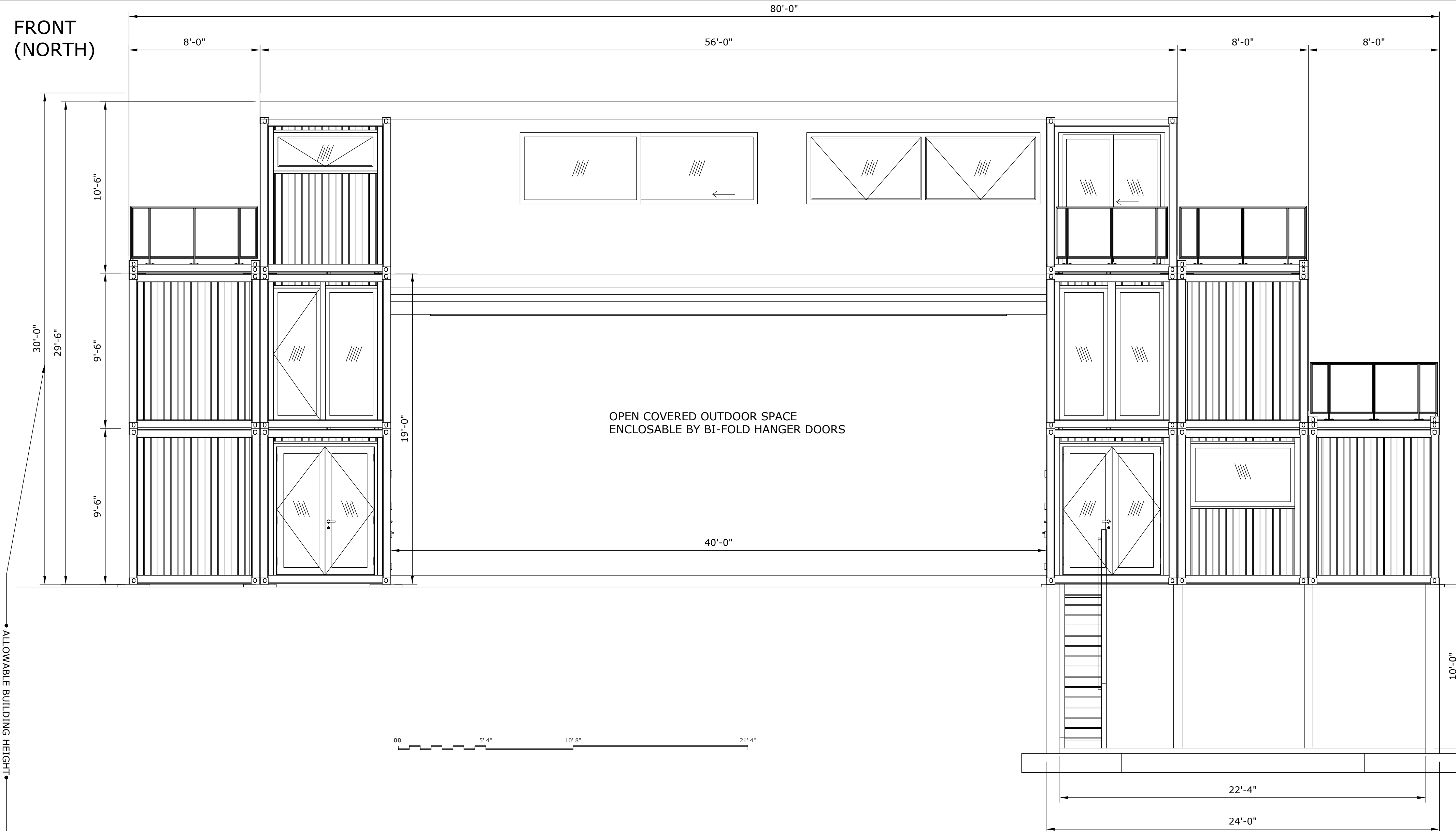

HANGER DOOR DETAILS

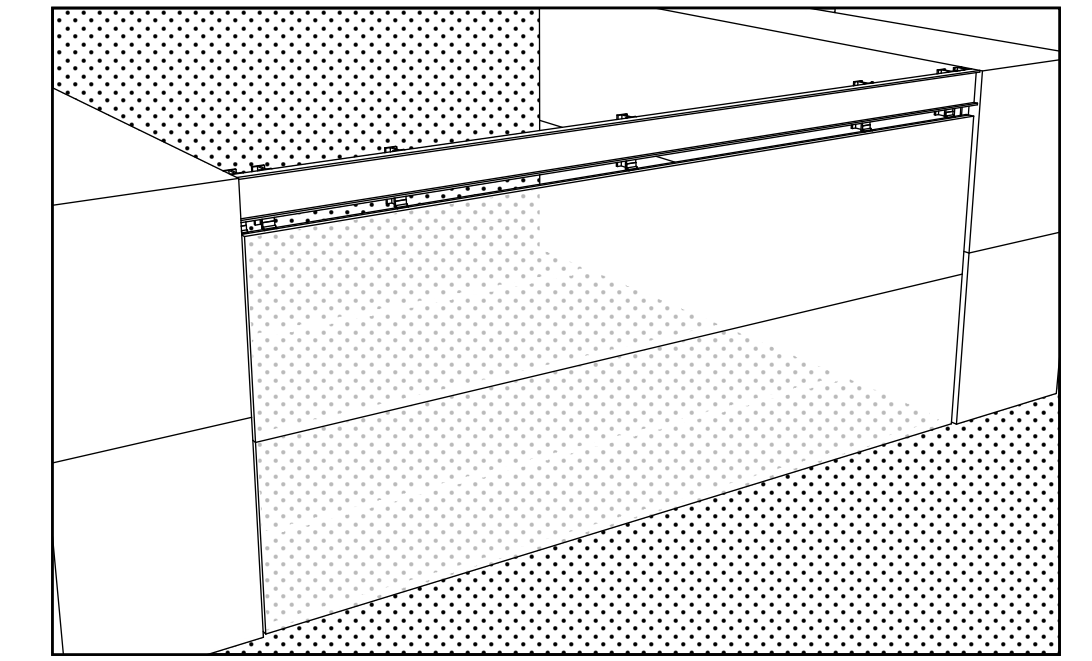

HANGER DOOR - CLOSED

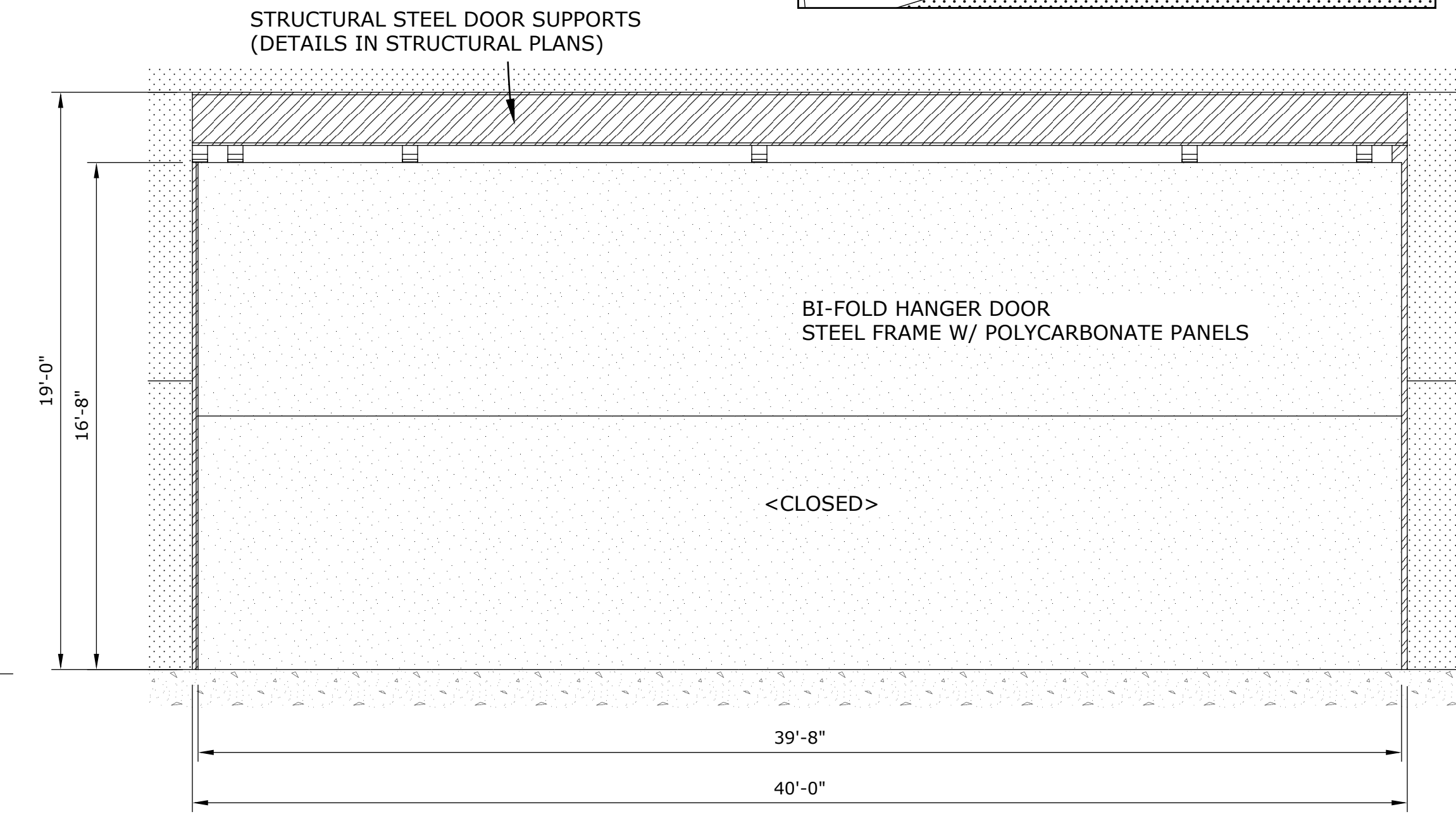

HANGER DOOR - OPENED

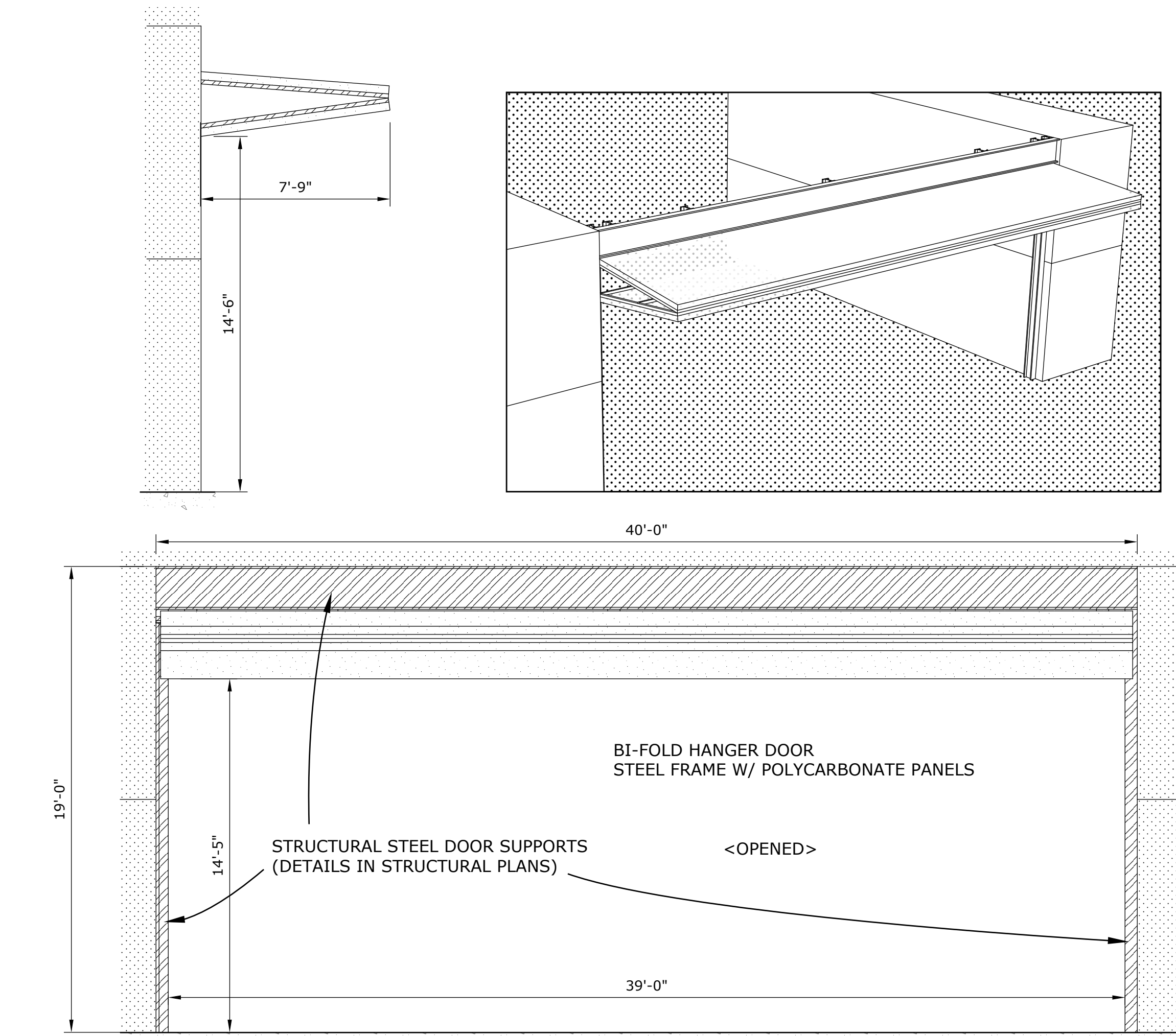

WEST SIDE EXTERIOR

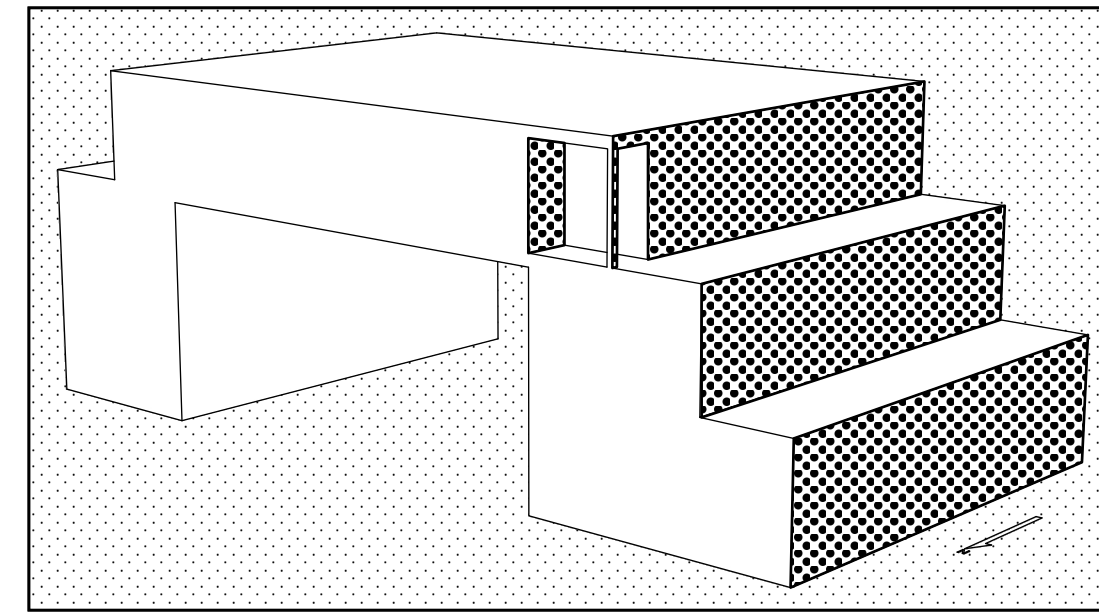
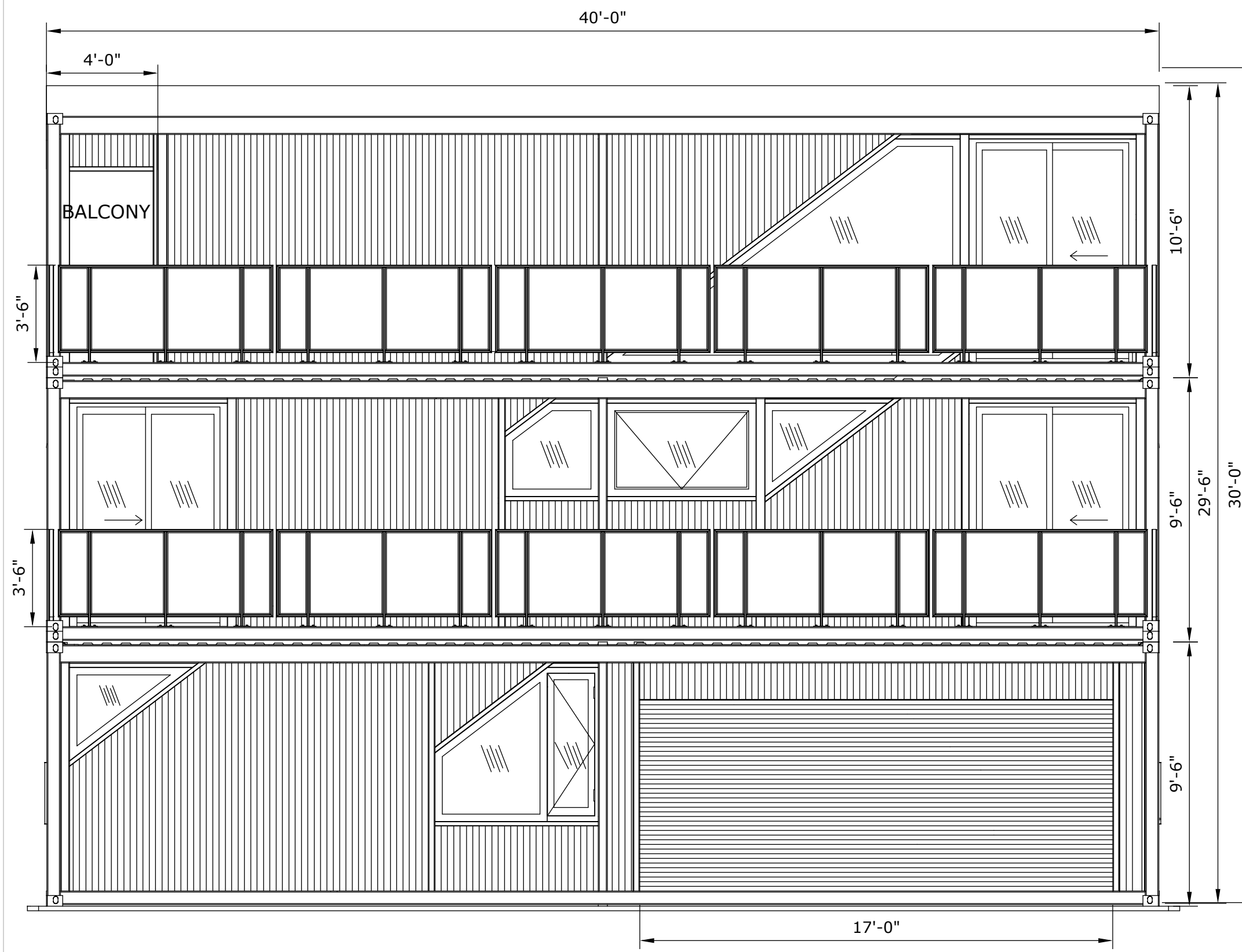

WEST SIDE INTERIOR

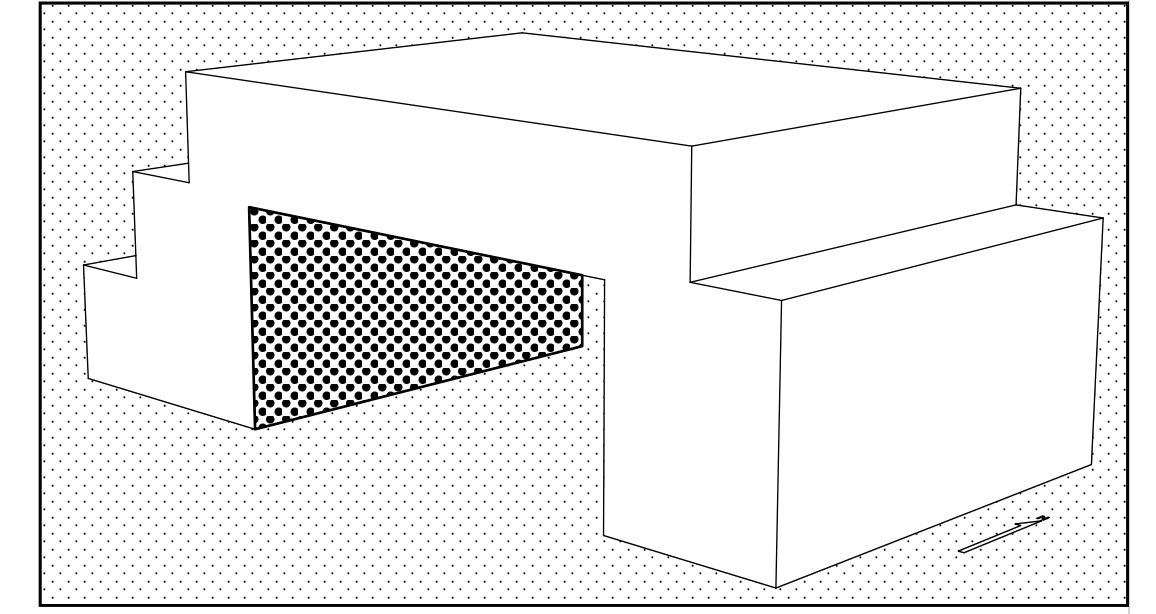
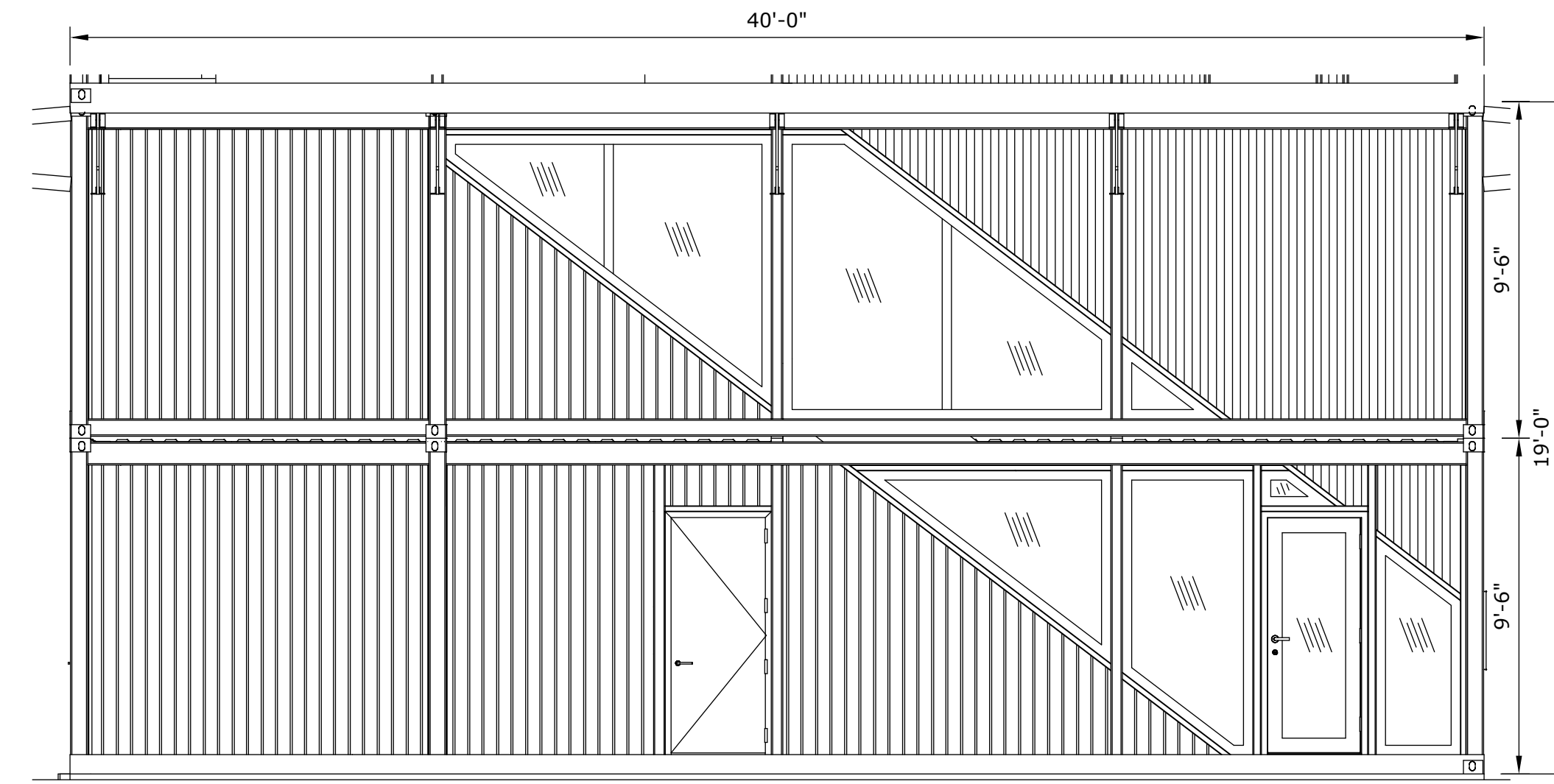

• ALLOWABLE BUILDING HEIGHT

EAST SIDE EXTERIOR

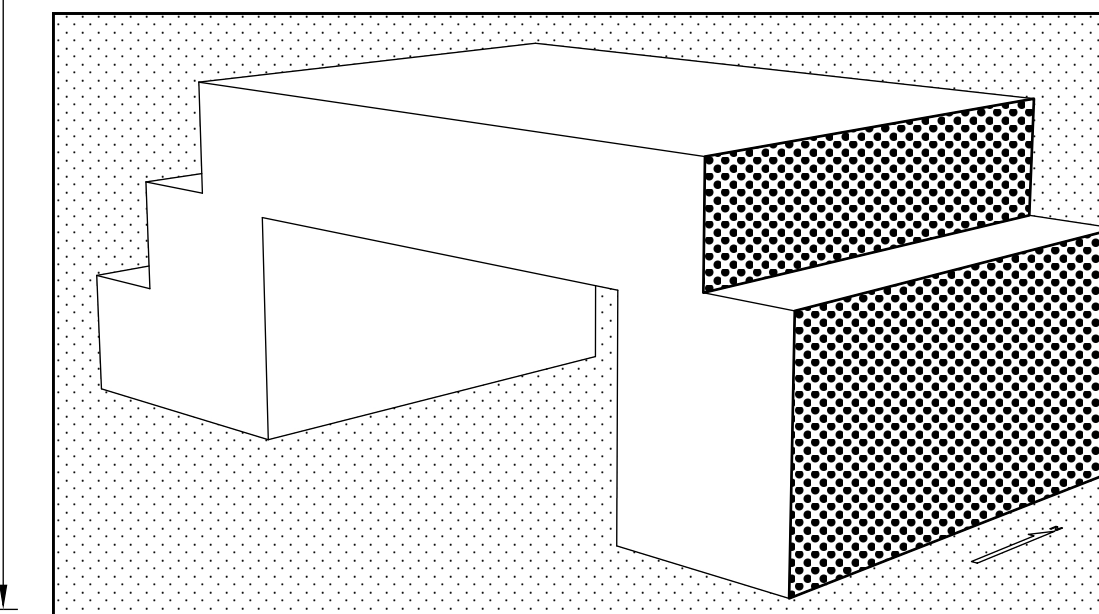
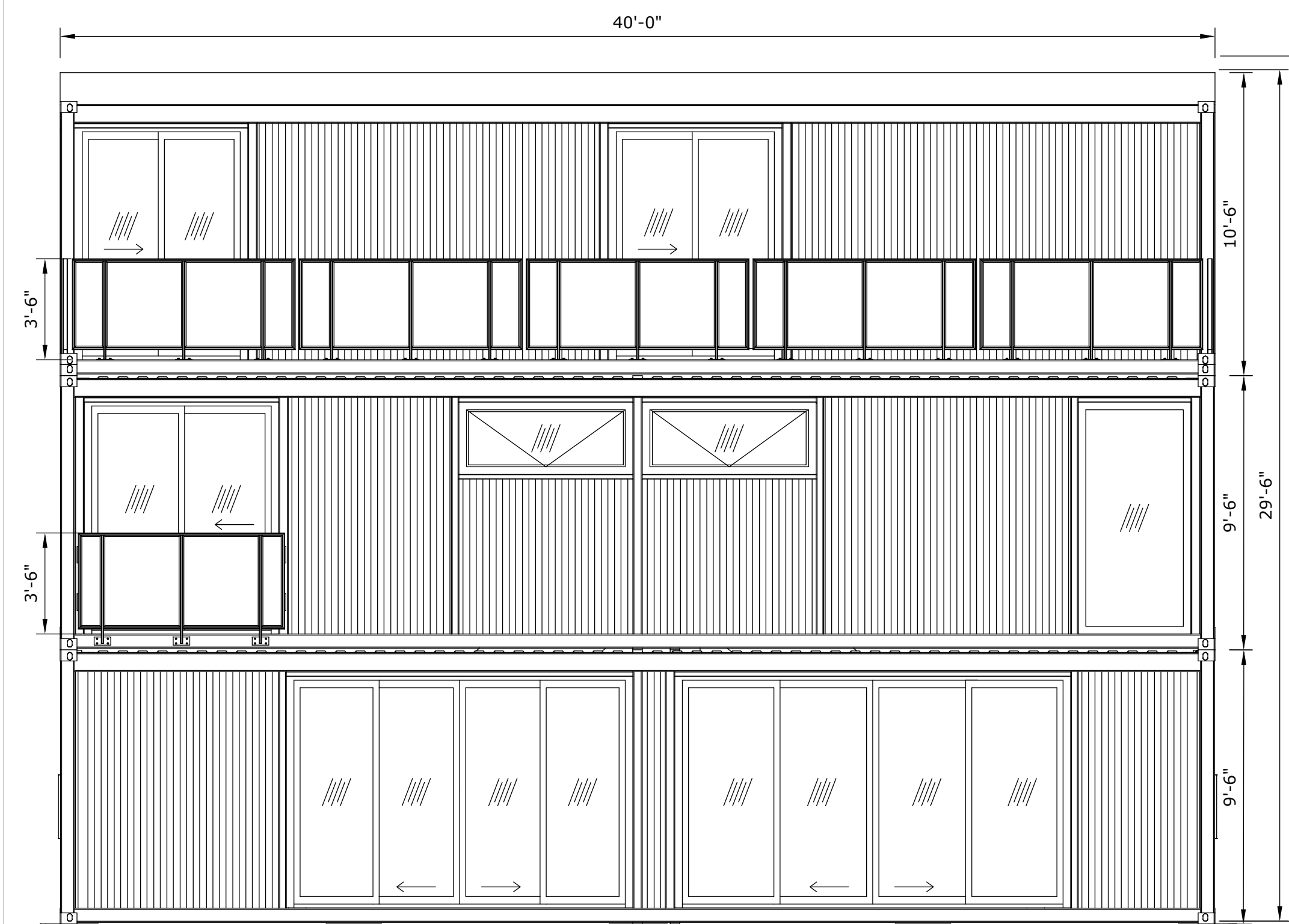

EAST SIDE INTERIOR

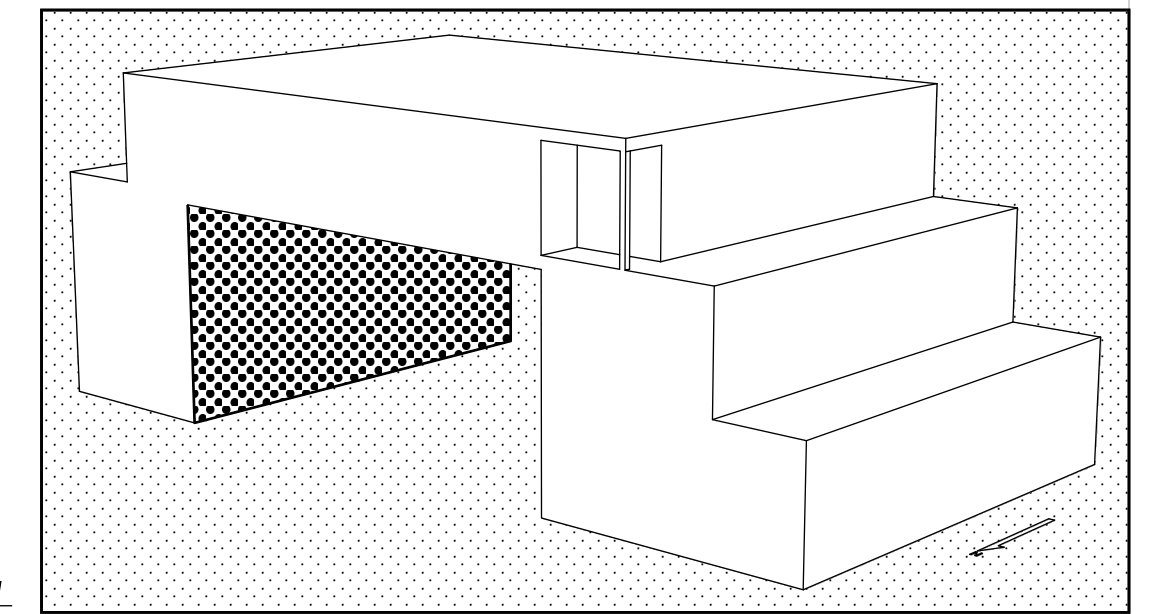
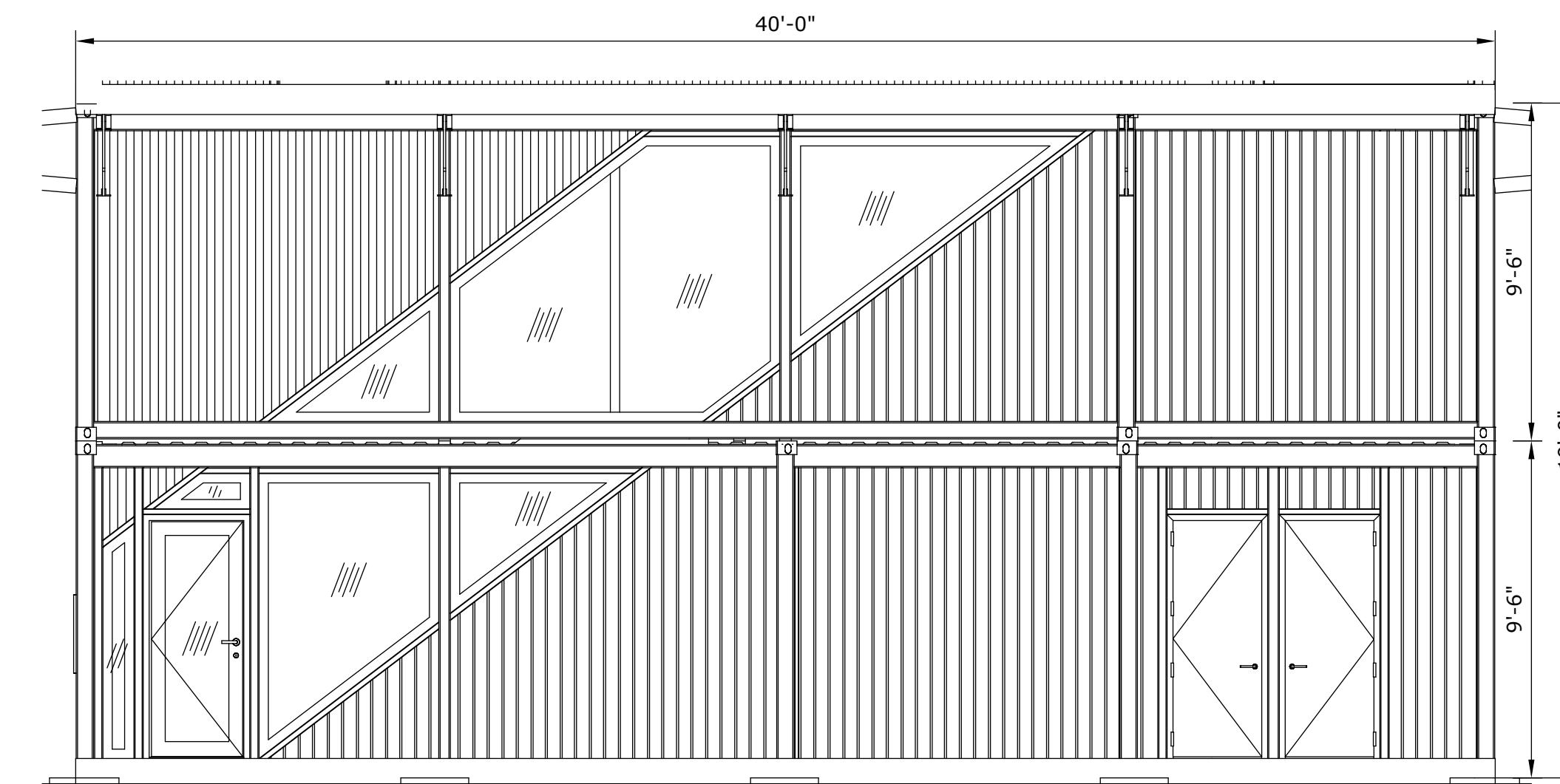

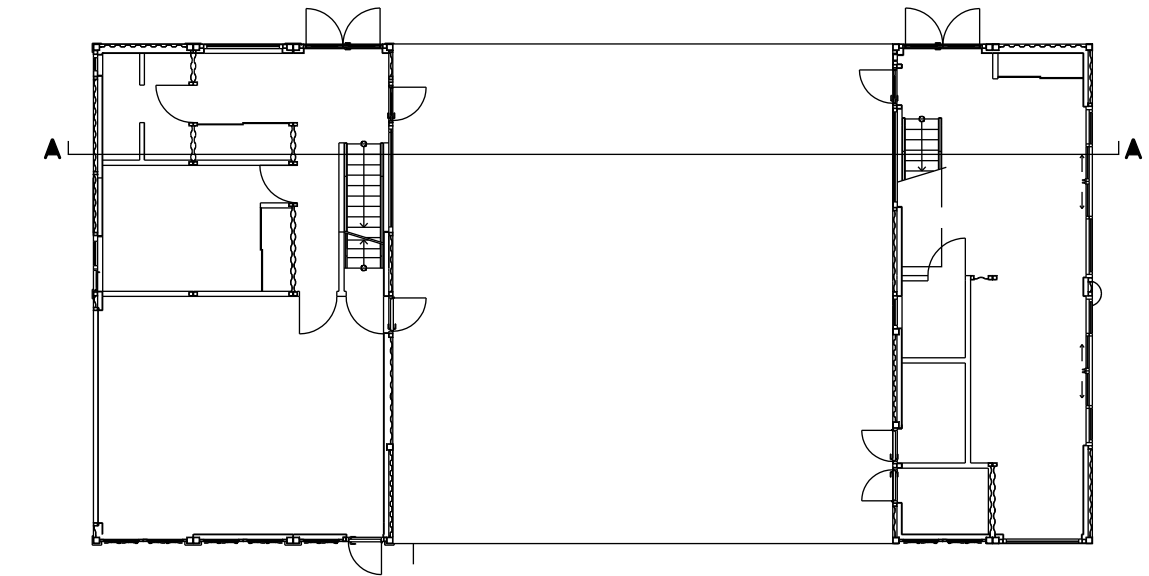
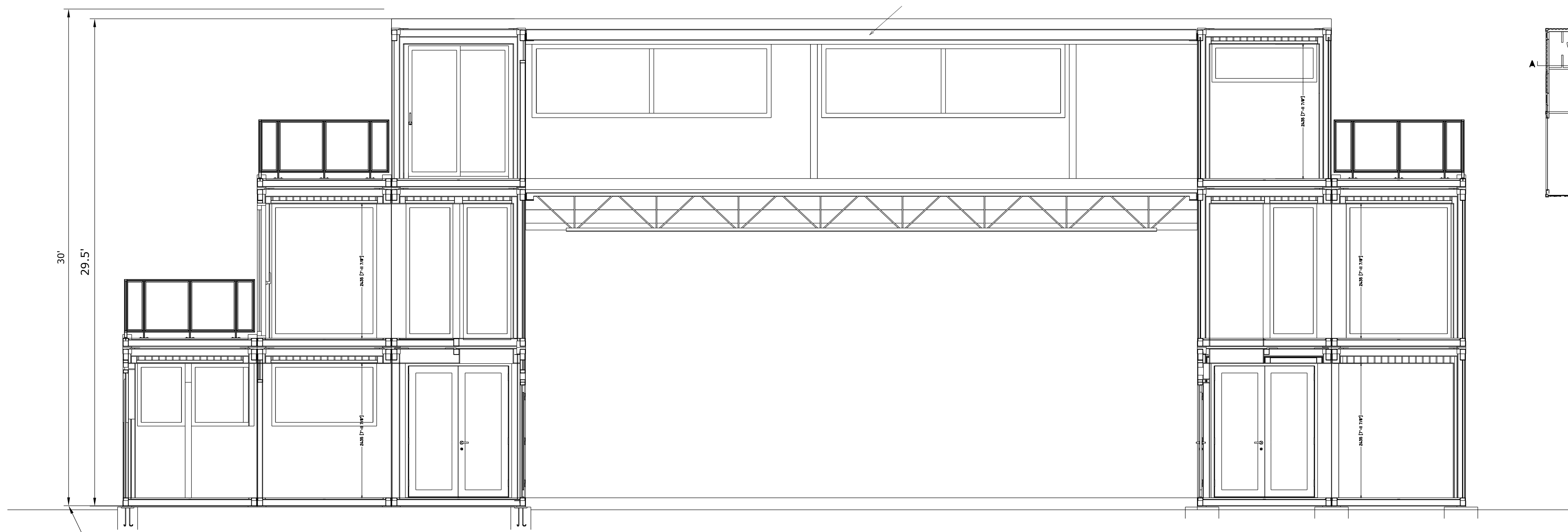

MAXIMUM BUILDING HEIGHT

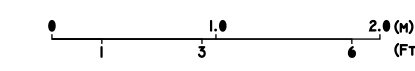

SECTION A-A

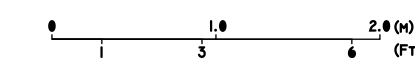
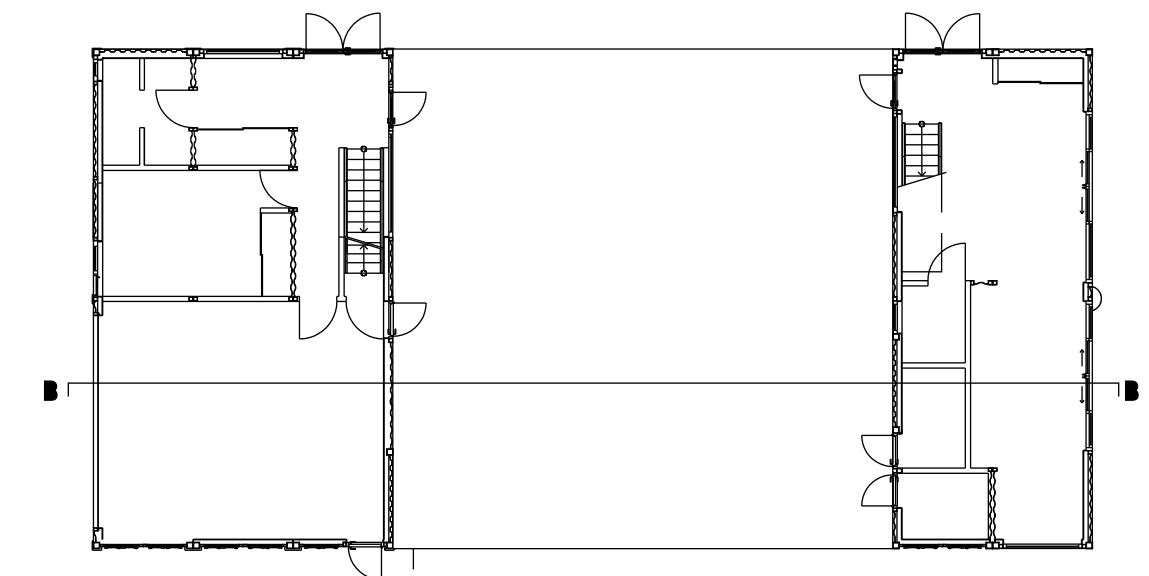
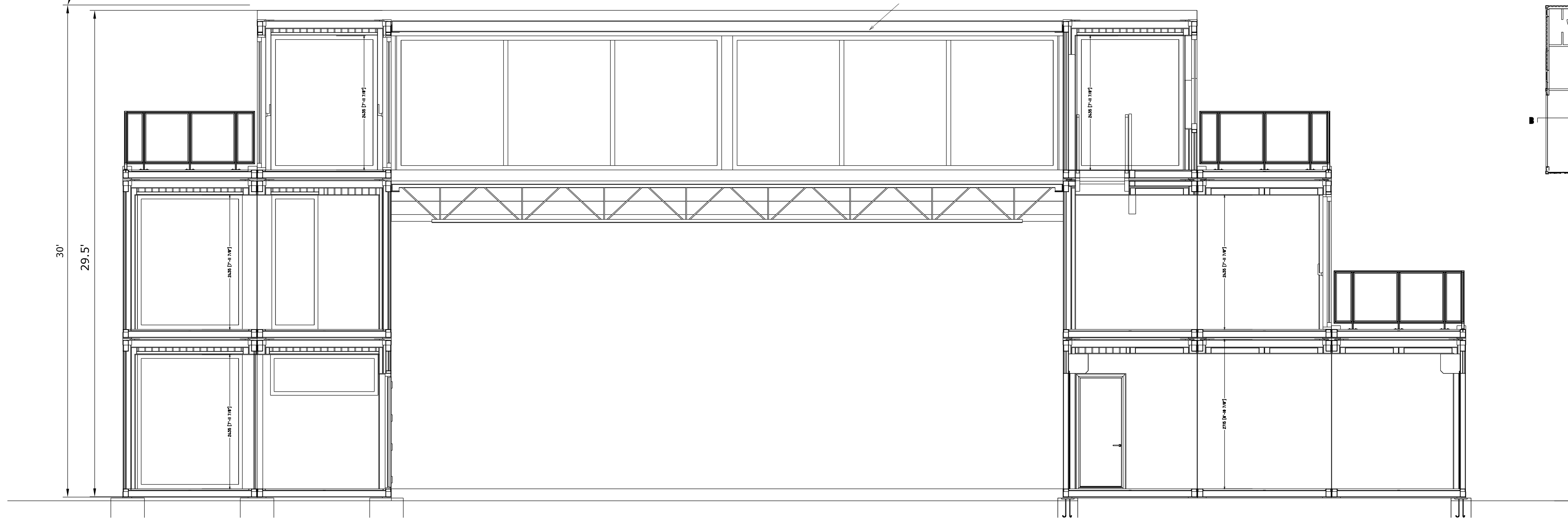



SUMMARY: WSEC 2018 THERMAL ENVELOPE COMPLIANCE

SECTION R402 BUILDING THERMAL ENVELOPE
 R402.1 General (Prescriptive).

INSULATION AND FENESTRATION REQUIREMENTS BY COMPONENT	Requirement	Actual
All Climate Zones (TABLE R402.1.1)		
Component	Requirement	Actual
Fenestration U-Factor	0.30	0.29
Skylight U-Factor	0.50	-
Ceiling R-Value	49	50.13
Wood Frame Wall R-Value	21 int	21 int
Floor R-Value	30	30.41
Below-Grade Wall R-value	10/15/21 int + 5TB	10/15/21 int + 5TB
Slab R-Value	10, 2 ft	-

SUMMARY: WSEC 2018 - ENERGY OPTION SELECTIONS [EQUIPMENT REQUIREMENTS]

SECTION R406 ADDITIONAL ENERGY EFFICIENCY REQUIREMENTS. This house classifies as a "medium dwelling unit" as defined in R406.3; therefore, this house shall be built with the following options:

6.0 Credits are required.

TABLE R406.2 FUEL NORMALIZATION CREDITS.

Selected: Heating option 2: Heat pump, +1 Credit.

[REQUIRED EQUIPMENT]

For an initial heating system using a heat pump that meets federal standards for the equipment listed in Table C403.3.2(1)C or C403.3.2(2) or Air to water heat pump units that are configured to provide both heating and cooling and are rated in accordance with AHRI 550/590

TABLE 406.3 ENERGY CREDITS.

Selected: High Efficiency HVAC, option 3.6, +2 Credits.

[REQUIRED EQUIPMENT]

Ductless split system heat pumps with no electric resistance heating in the primary living areas. A ductless heat pump system with a minimum HSPF of 10 shall be sized and installed to provide heat to entire dwelling unit at the design outdoor air temperature.

Selected: Efficient Water Heating, option 5.5, +2 Credits.

[REQUIRED EQUIPMENT]

Electric heat pump water heater meeting the standards for Tier III of NEEA's advanced water heating specification.

Selected: Renewable Electric Energy, option 6.1, +1 Credit.

[REQUIRED EQUIPMENT]

Solar system designed to generate at least 1200 kWh.

TOTAL CREDITS: 6

SUMMARY: IRC 2018 - M1505.4 - WHOLE-HOUSE MECHANICAL VENTILATION SYSTEM

Each dwelling unit must have a ventilation system which consists of one or more supply or exhaust fans or a combination of such. According to WSU Energy Program's guide on this topic, it therefore acceptable to use only exhaust fans, and using bathroom vent fans or kitchen oven hoods are acceptable for this purpose. However, only using bathroom exhaust vents is considered "not balanced" and "not distributed" which implies a 1.5x system coefficient penalty, per TABLE M1505.4.3(2). The base ventilation requirement is 95 CFM per TABLE M1505.4.3(1) based on this house's square footage and bedroom, or 95 CFM * 1.5 (system coefficient) = 142.5 CFM. The system may run intermittently, offset by the factors outlined in TABLE M1505.4.3(3), but we will just run the fans all of the time which keeps the factor at 1.0x.

[VENTILATION SYSTEM EQUIPMENT REQUIREMENTS]

2x bathroom vents totaling at least 142.5 CFM combined flow rate. These are to run continuously.

SUMMARY: WSEC RESIDENTIAL 2018 - REQUIREMENTS

R402.2.7 Floors

Floor framing cavity insulation shall be installed to maintain permanent contact with the underside of the subfloor decking. Insulation supports shall be installed so spacing is no more than 24 inches on center. Foundation vents shall be placed so that the top of the vent is below the lower surface of the floor insulation.

R402.2.8 Basement Walls

Below-grade exterior wall insulation used on the exterior (cold) side of the wall shall extend from the top of the below-grade wall to the top of the footing and shall be approved for below-grade use. Above-grade insulation shall be protected. Insulation used on the interior (warm) side of the wall shall extend from the top of the below-grade wall to the below-grade floor level and shall include R-5 rigid board providing a thermal break between the concrete wall and the slab.

R402.4.1.2 Testing.

The building or dwelling unit shall be tested and verified as having an air leakage rate of not exceeding 5 air changes per hour. Testing shall be conducted with a blower door at a pressure of 0.2 inches w.g. (50 Pascals). For this test only, the volume of the home shall be the conditioned floor area in ft2 (m2) multiplied by 8.5 feet (2.6 m). Where required by the code official, testing shall be conducted by an approved third party. A written report of the results of the test shall be signed by the party conducting the test and provided to the code official. Testing shall be performed at any time after creation of all penetrations of the building thermal envelope. Once visual inspection has confirmed sealing (see Table R402.4.1.1), operable windows and doors manufactured by small business shall be permitted to be sealed off at the frame prior to the test.

R403.4 Mechanical system piping insulation.

Mechanical system piping capable of carrying fluids above 105°F (41°C) or below 55°F (13°C) shall be insulated to a minimum of R-6.

R403.5 Service hot water systems.

Energy conservation measures for service hot water systems shall be in accordance with Sections R403.5.1 through R403.5.5. Service water-heating equipment shall meet the requirements of DOE 10 CFR Part 430 Union Energy Factor or the equipment shall meet the requirements of Section C404.2.

R403.6 Mechanical ventilation.

The building shall be provided with ventilation that meets the requirements of the International Residential Code or International Mechanical Code, as applicable, or with other approved means of ventilation. Outdoor air intakes and exhausts shall have automatic or gravity dampers that close when the ventilation system is not operating.

CONTAINER INSULATION DETAIL

DET. 1 - FRONT WALL SECTION

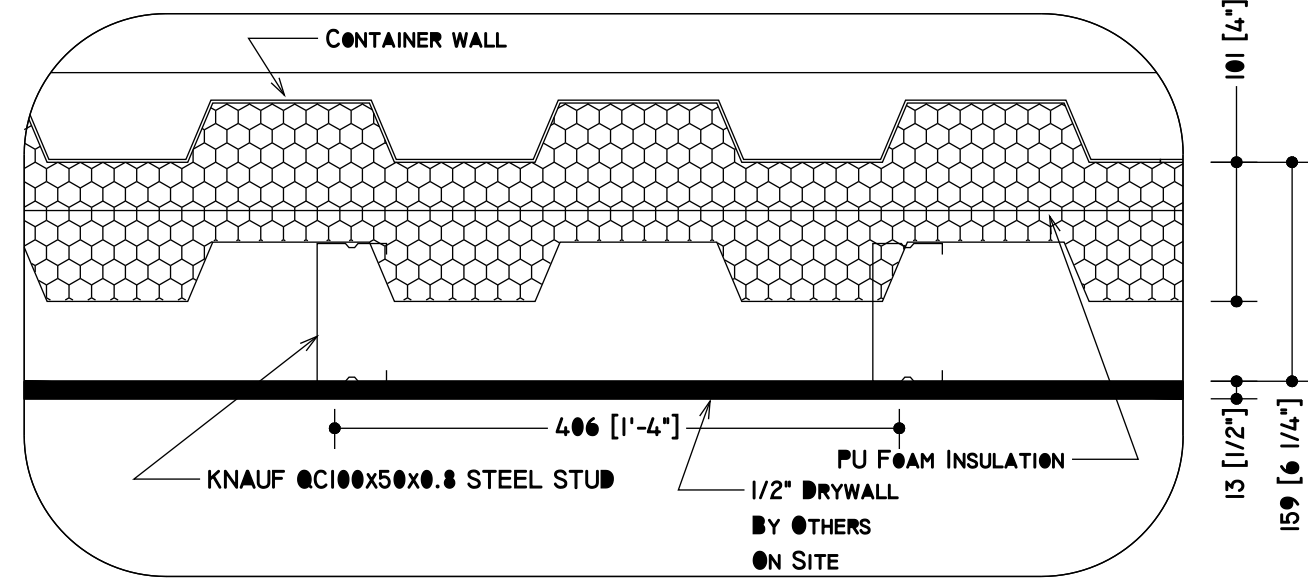

DET. 2 - FRONT WALL SECTION AT JOINT

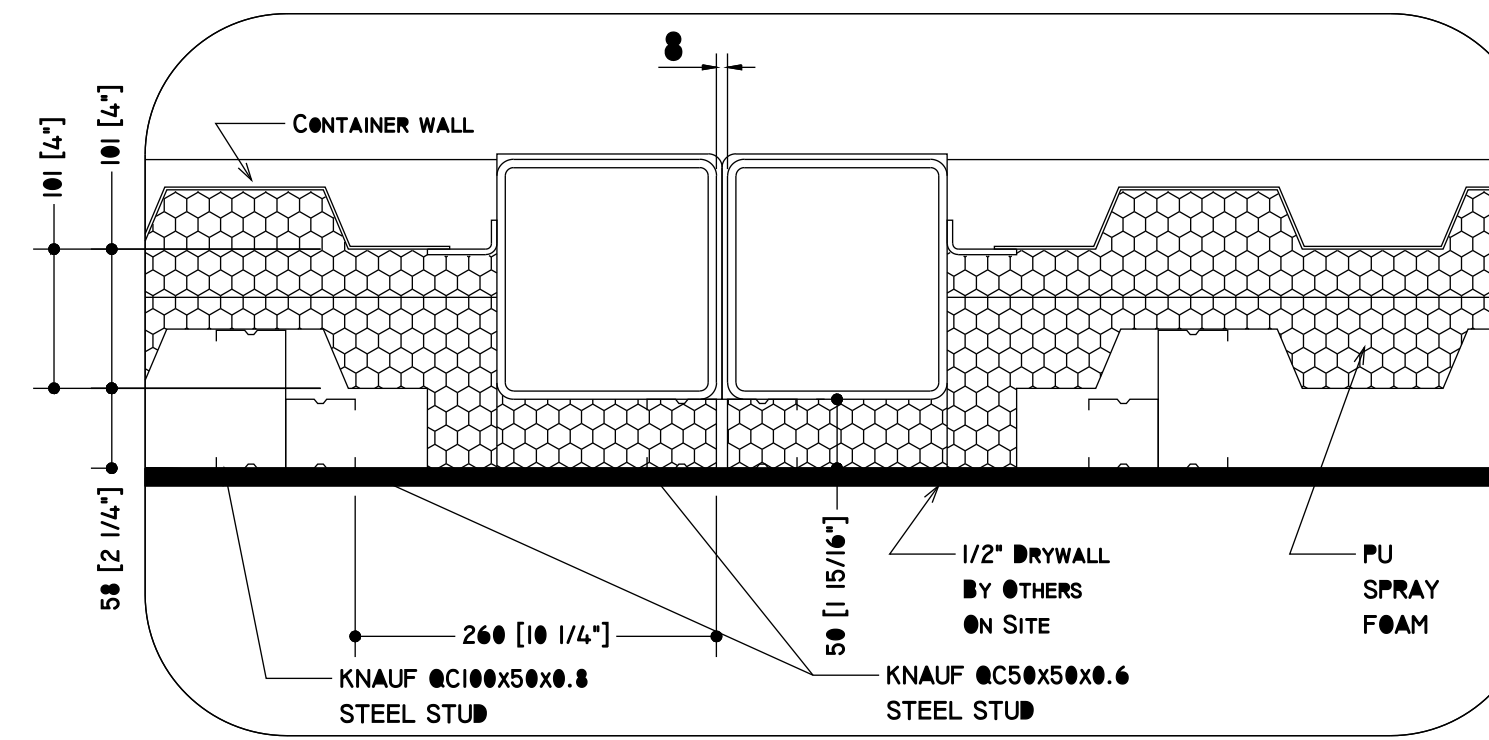

DET. 3 - SIDE WALL SECTION

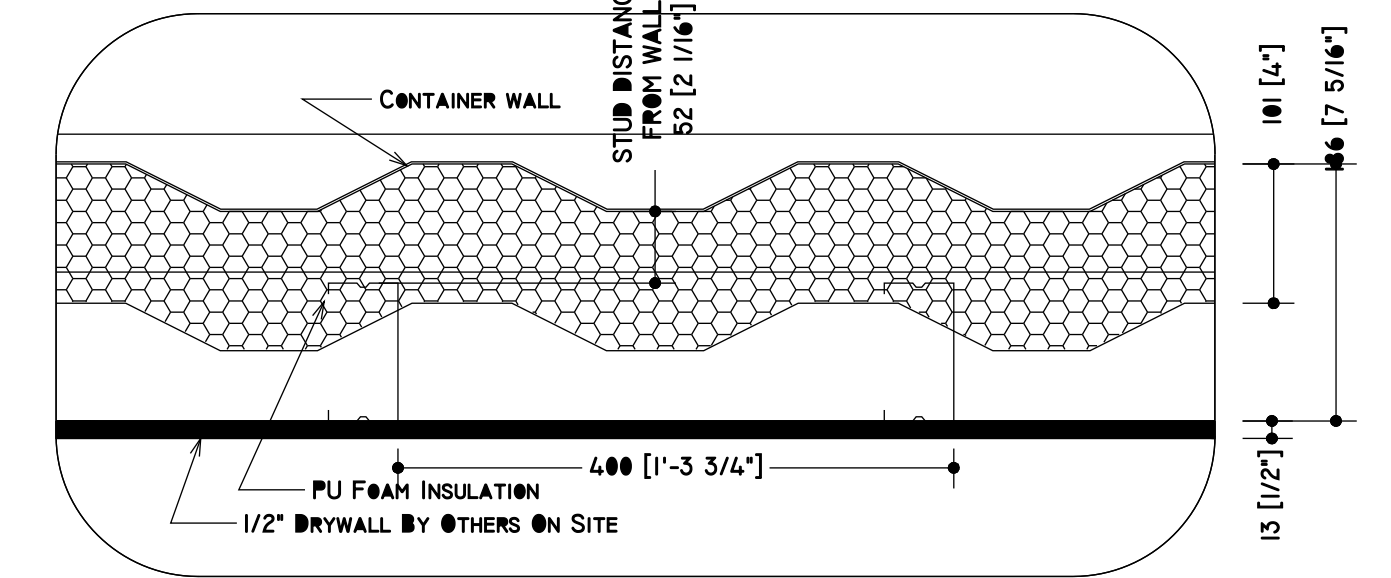

DET. 4 - FLOOR SECTION

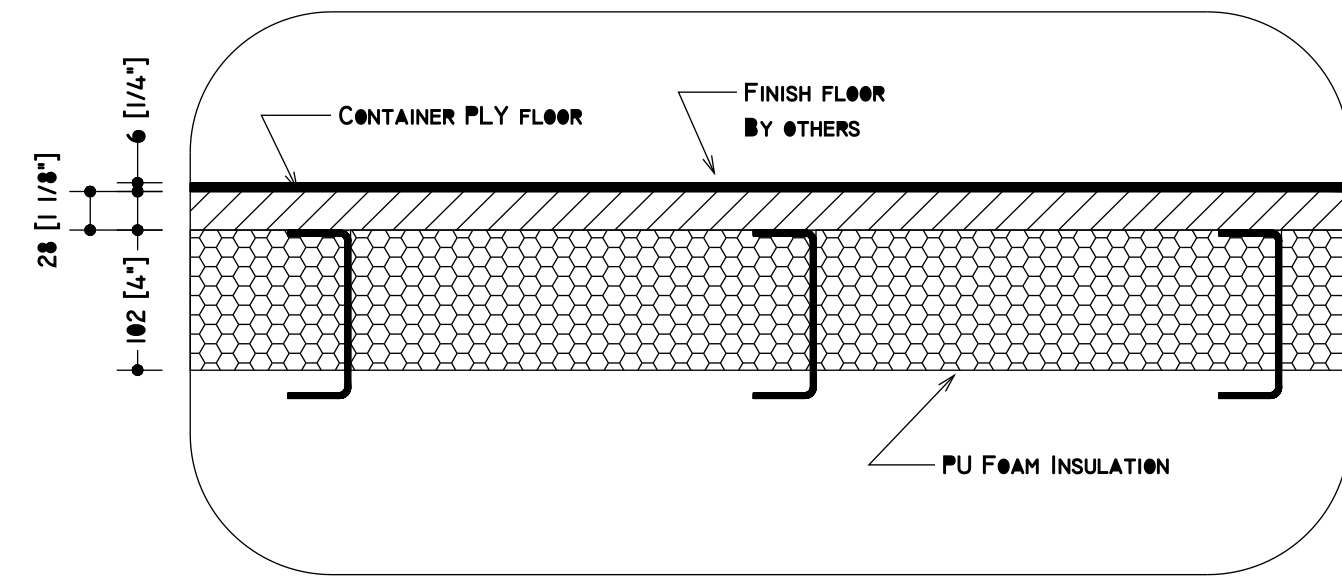

DET. 5 - ROOF SECTION AT JOINT

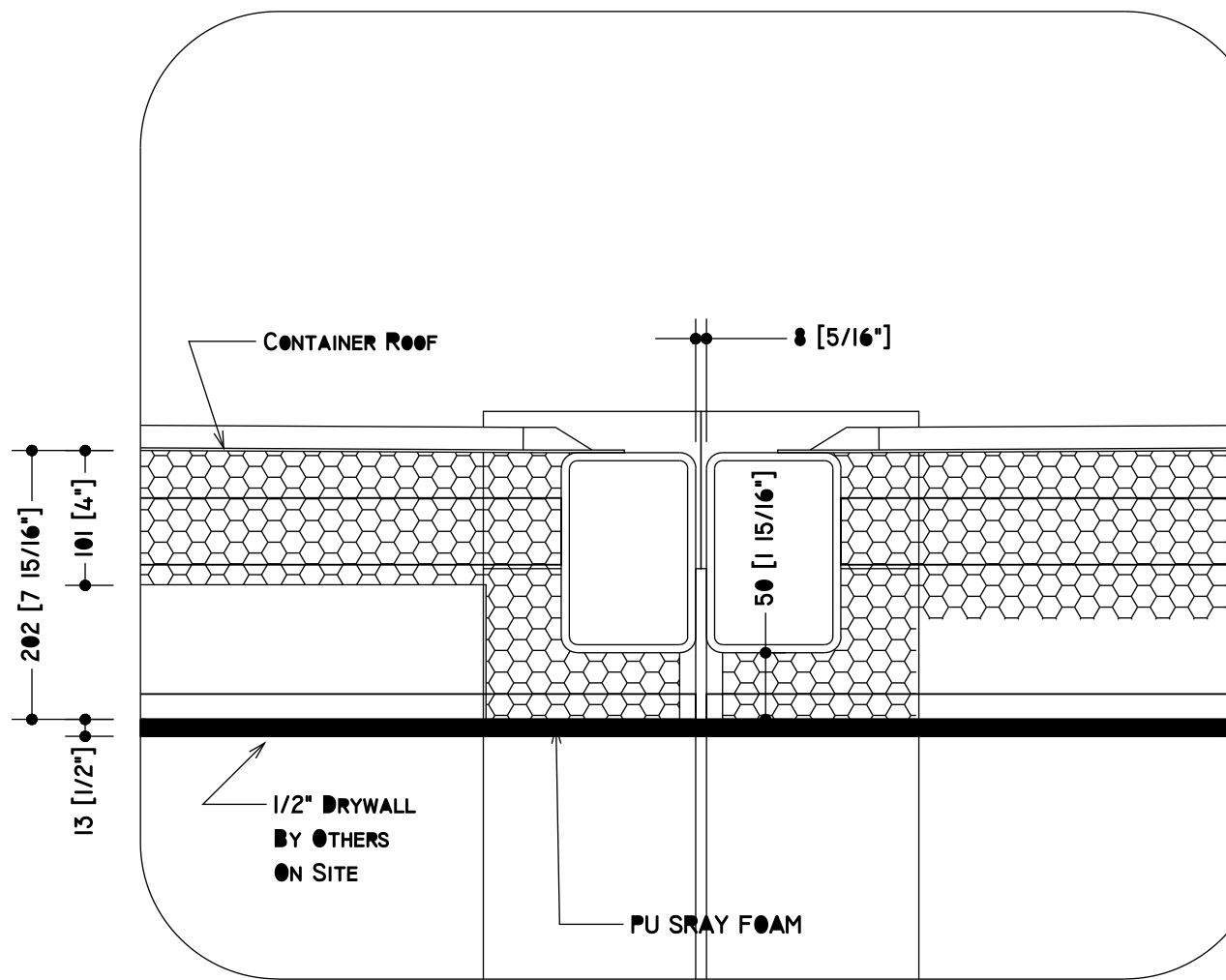

DET. 6 - ROOF SECTION

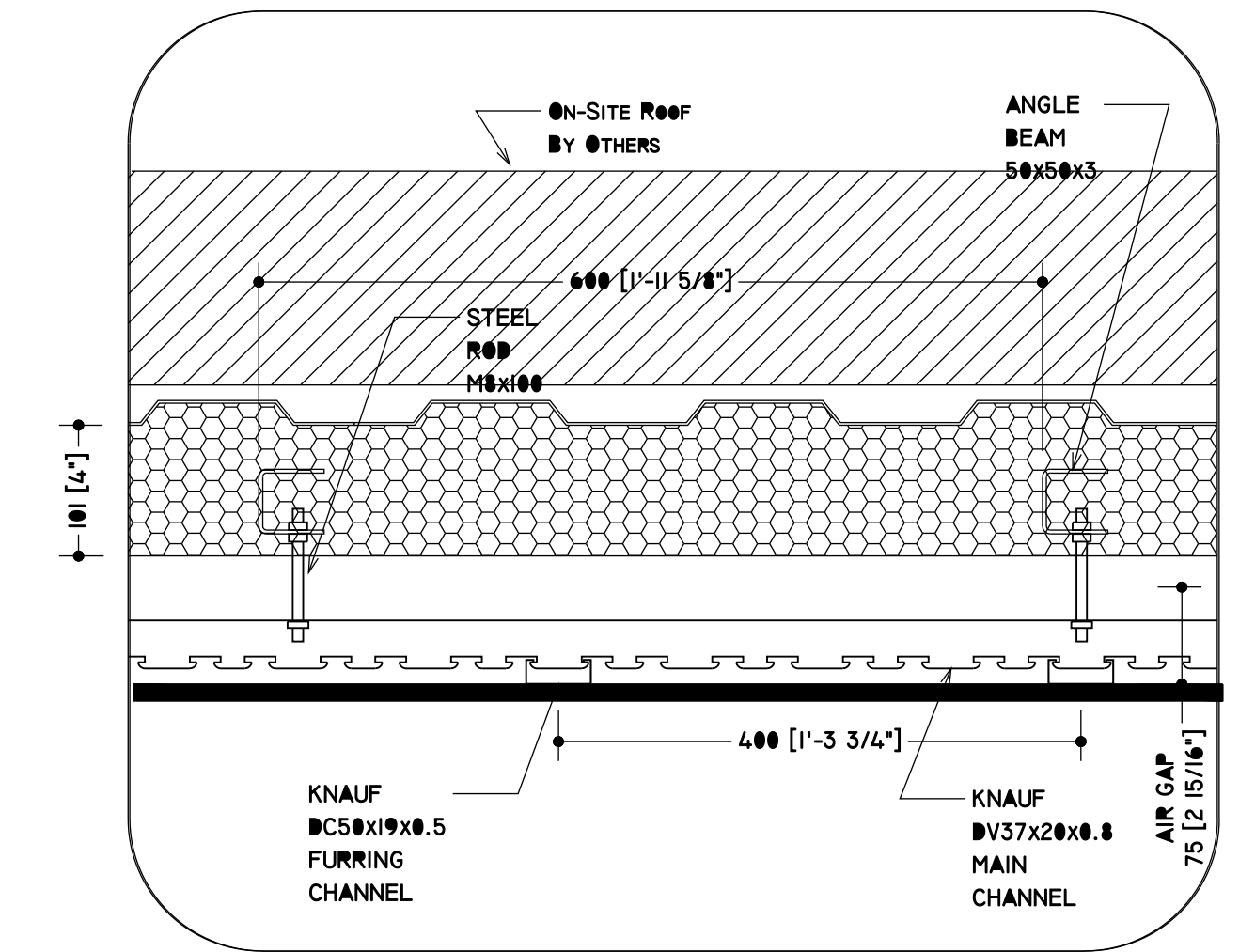

DET. 7 - ROOF SECTION AT DECKS

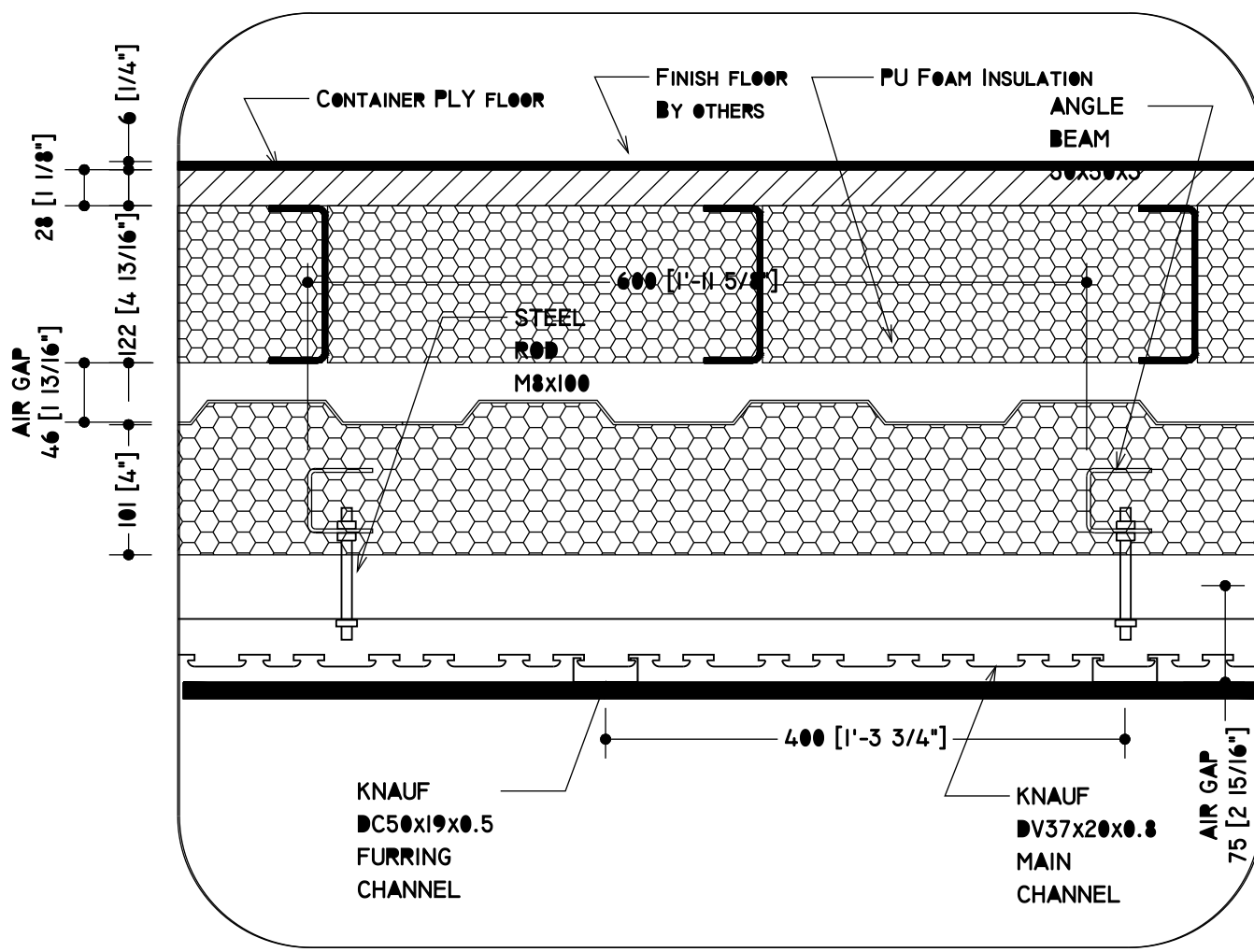

*CONNECTION BETWEEN DECK AND CONTAINER ROOF SEALED AND INSULATED ON SITE BY OTHERS

INSULATION LEGEND			
ITEM	R-VALUE	INSULATION TYPE	THICKNESS (in)
CEILING	R-24	CLOSED CELL PU-FOAM	4
EXT WALL	R-24	CLOSED CELL PU-FOAM	4
FLOOR	R-24	CLOSED CELL PU-FOAM	4
ROOF AT DECK	R-52	CLOSED CELL PU-FOAM	4 + 4-13/16
ROOF		TBD	●ON-SITE, BY OTHERS
INT WALL		TBD	●ON-SITE, BY OTHERS

NOTE: GIANT CONTAINER PROVIDES INSULATION AT CEILING, EXT WALL, AND FLOOR ONLY.

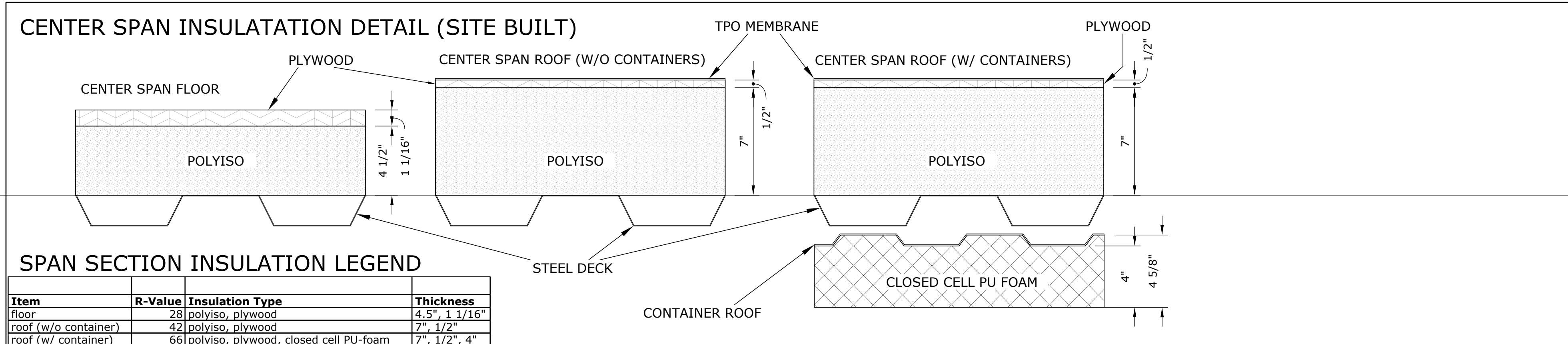

SPAN SECTION INSULATION LEGEND			
Item	R-Value	Insulation Type	Thickness
floor	28	polyiso, plywood	4.5", 1 1/16"
roof (w/o container)	42	polyiso, plywood	7", 1/2"
roof (w/ container)	66	polyiso, plywood, closed cell PU-foam	7", 1/2", 4"

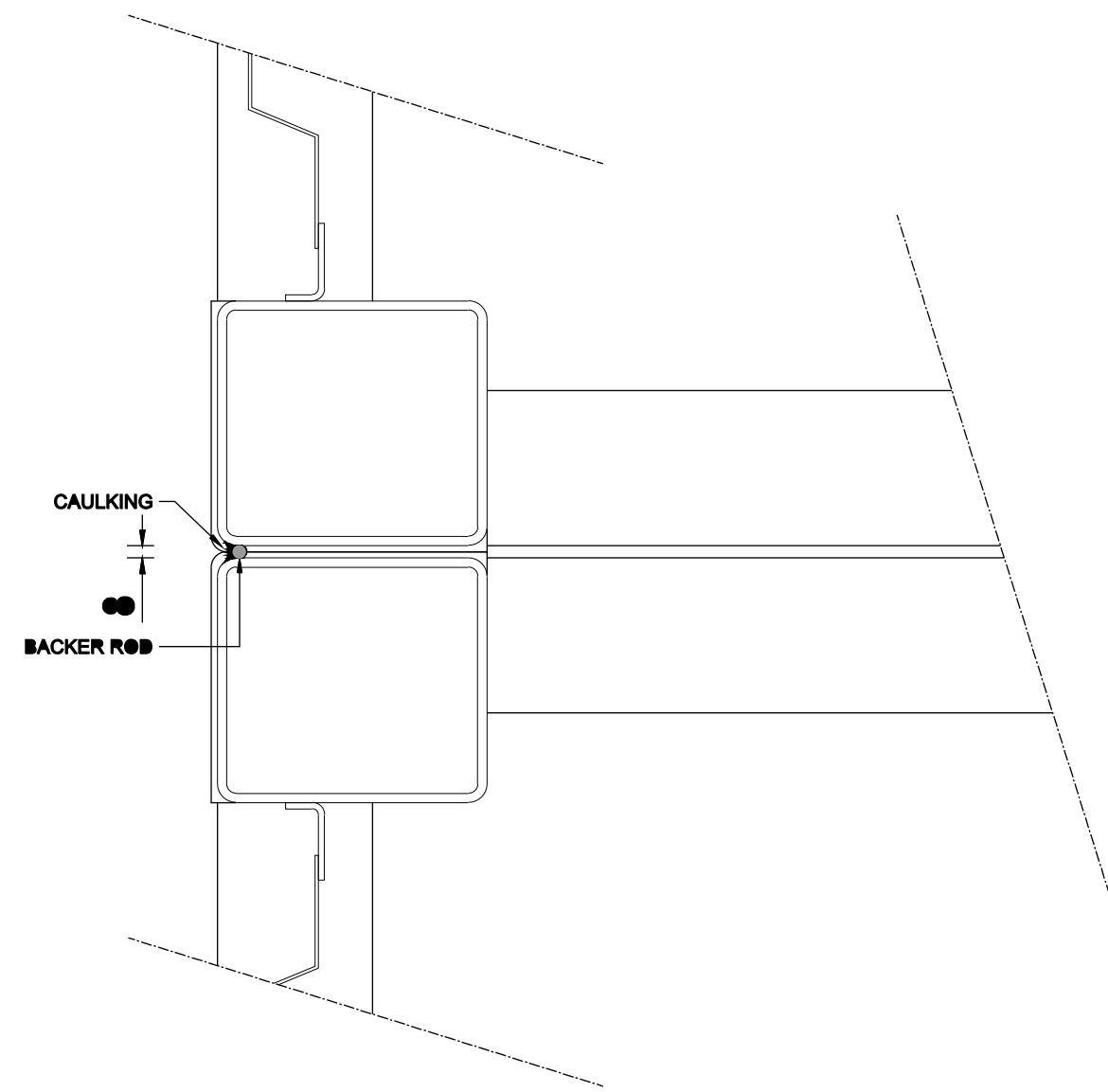

● OPEN SIDE-SIDE DETAIL PLAN

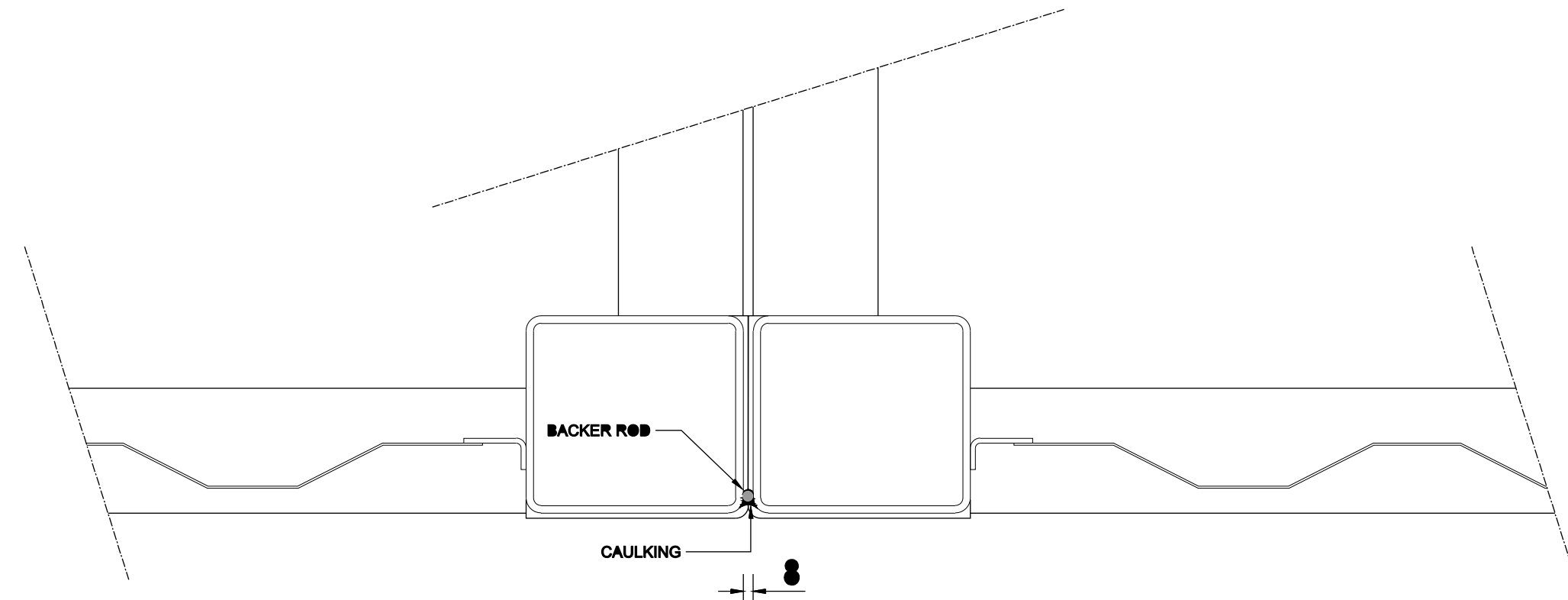

● OPEN REAR END - FRONT END DETAIL PLAN

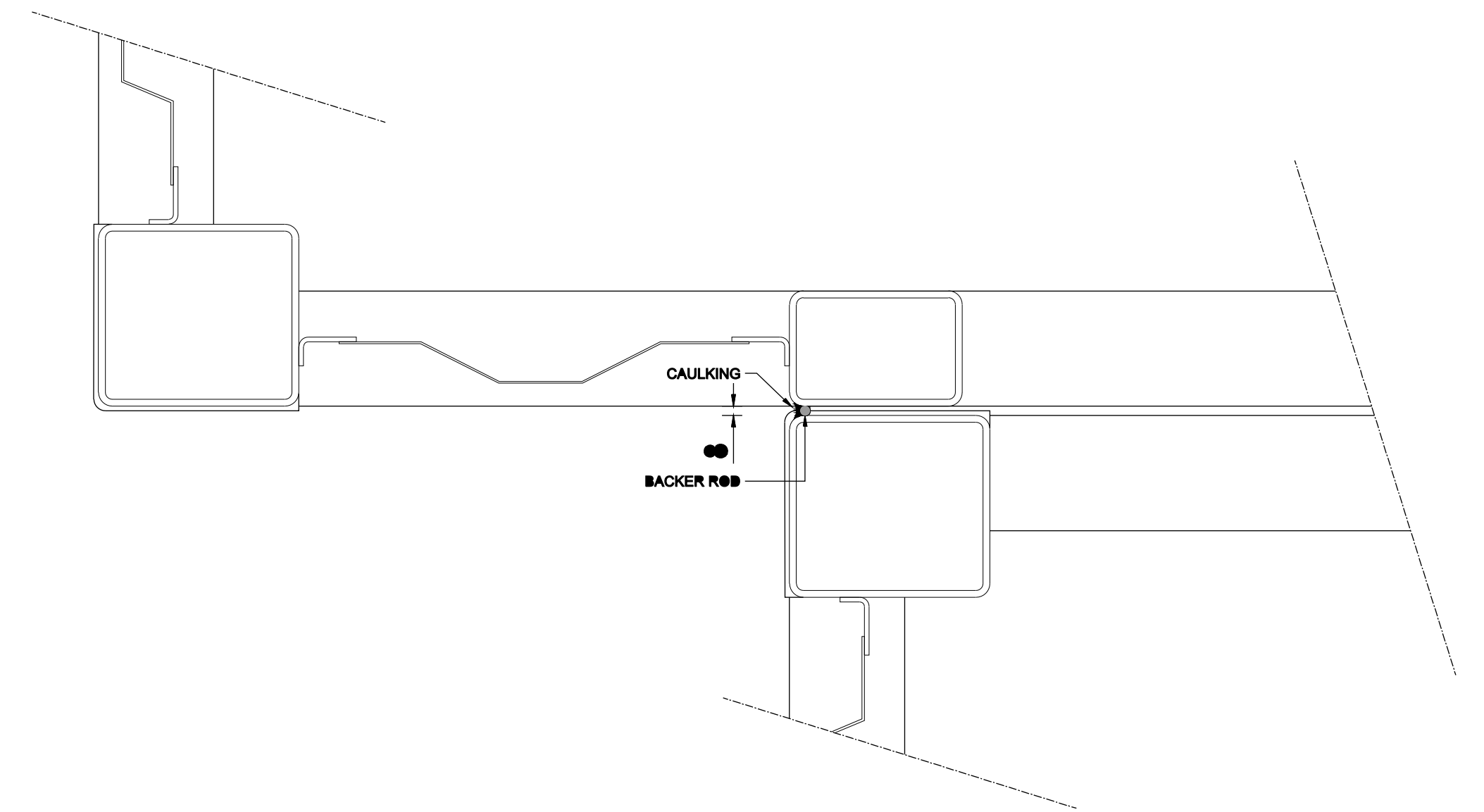

● OPEN SIDE-SIDE OFFSET DETAIL PLAN

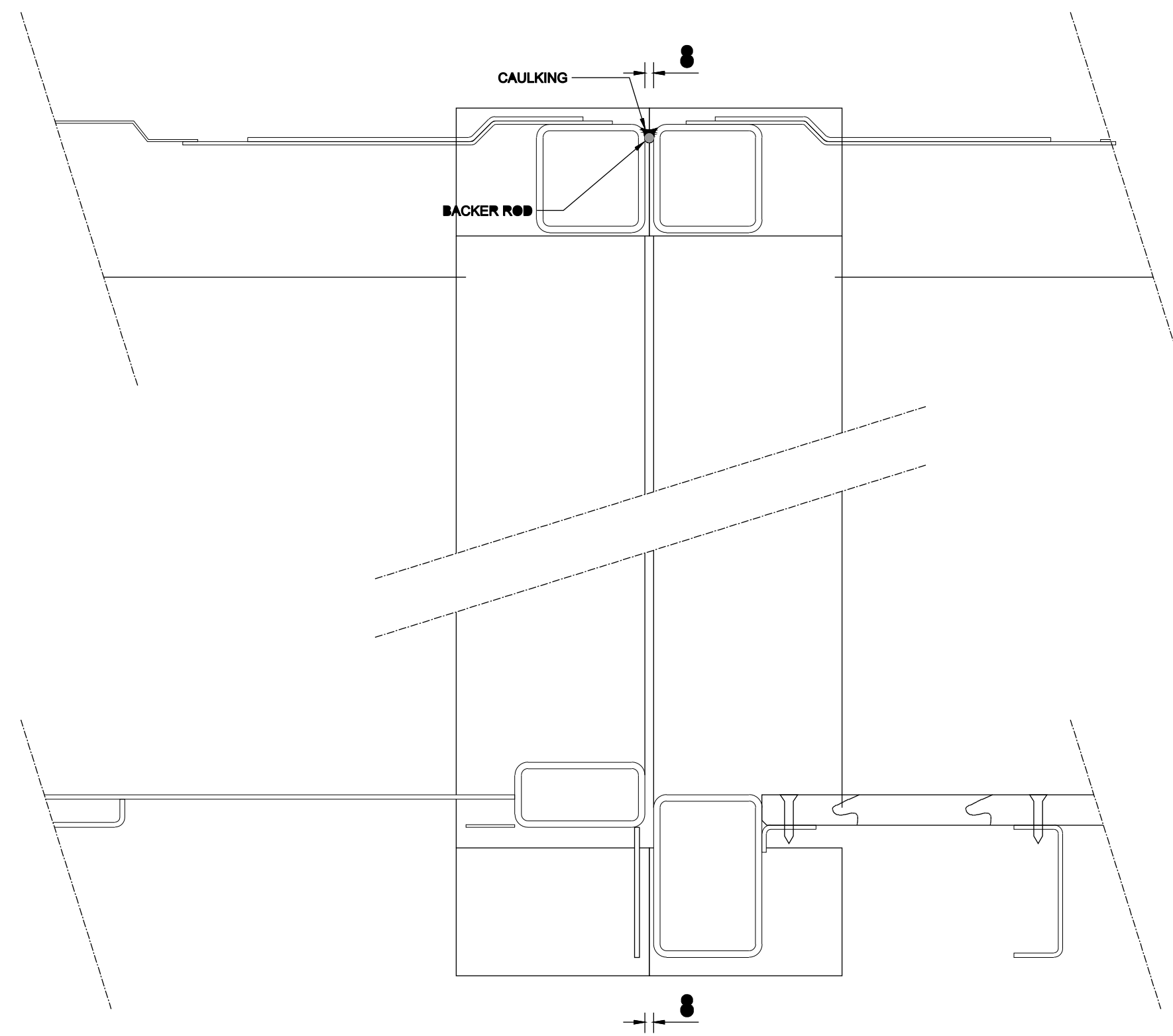

● OPEN REAR END - FRONT END DETAIL SECTION

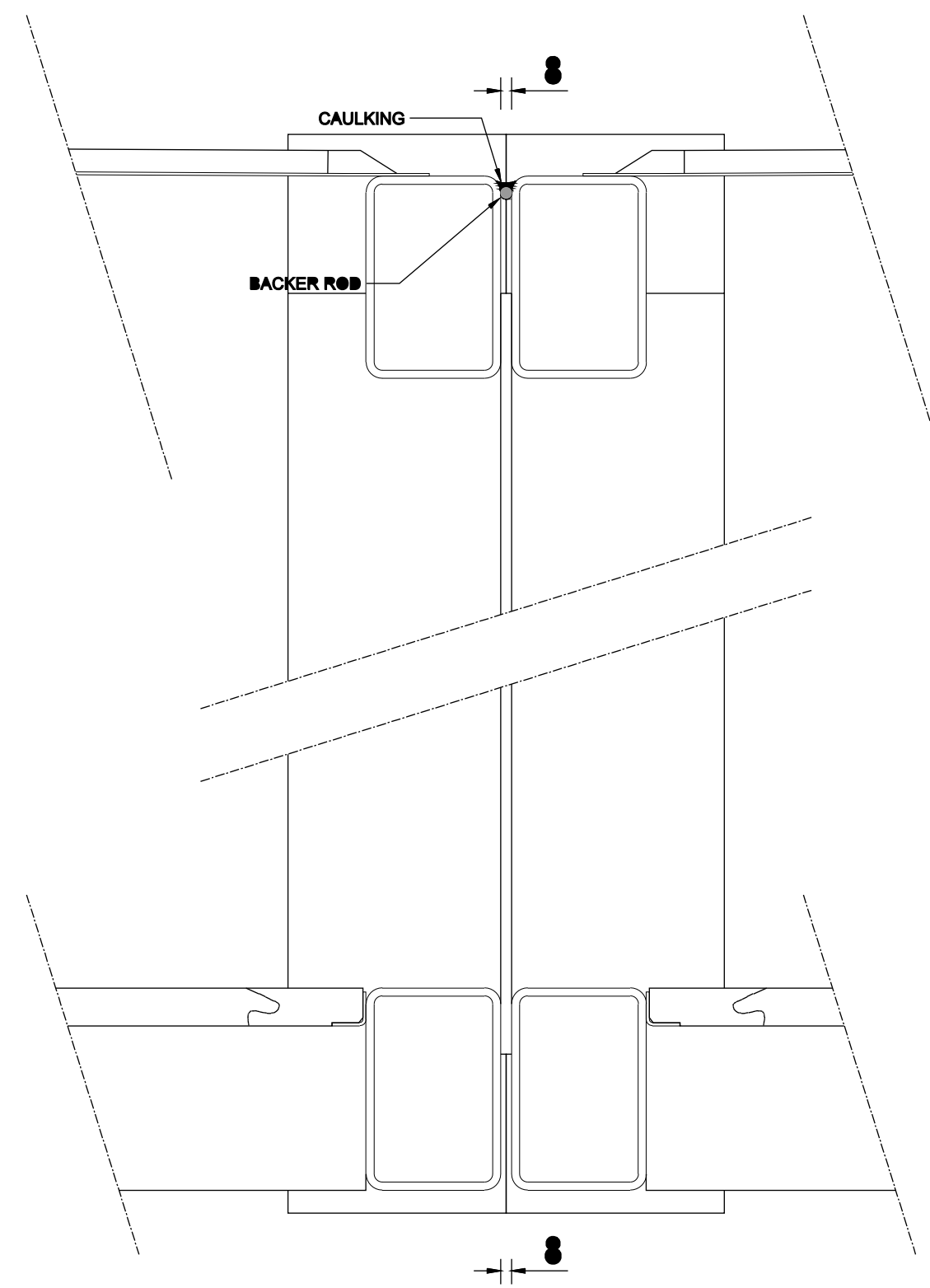

● OPEN SIDE-SIDE DETAIL SECTION

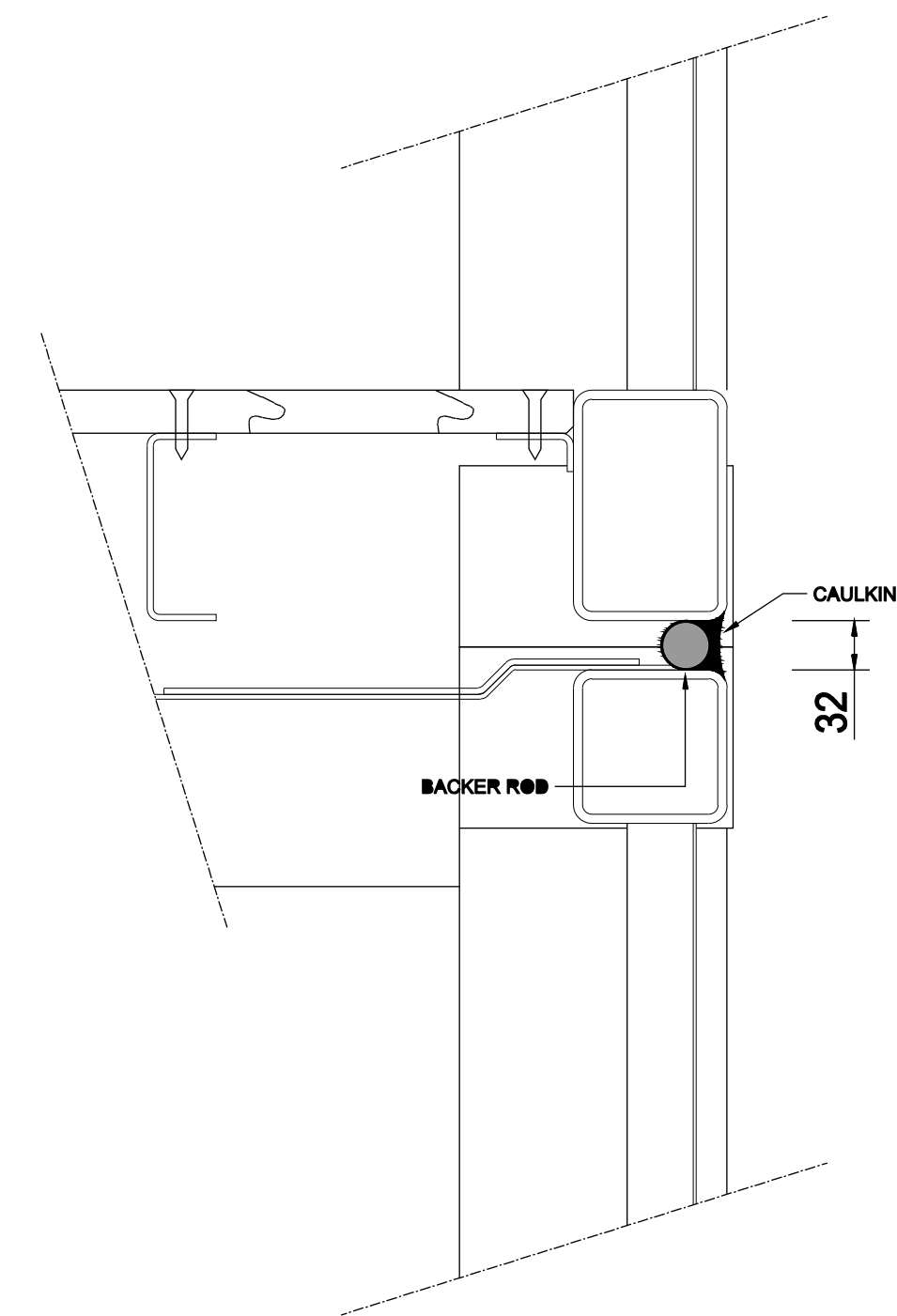

● REAR END VERTICAL DETAIL SECTION

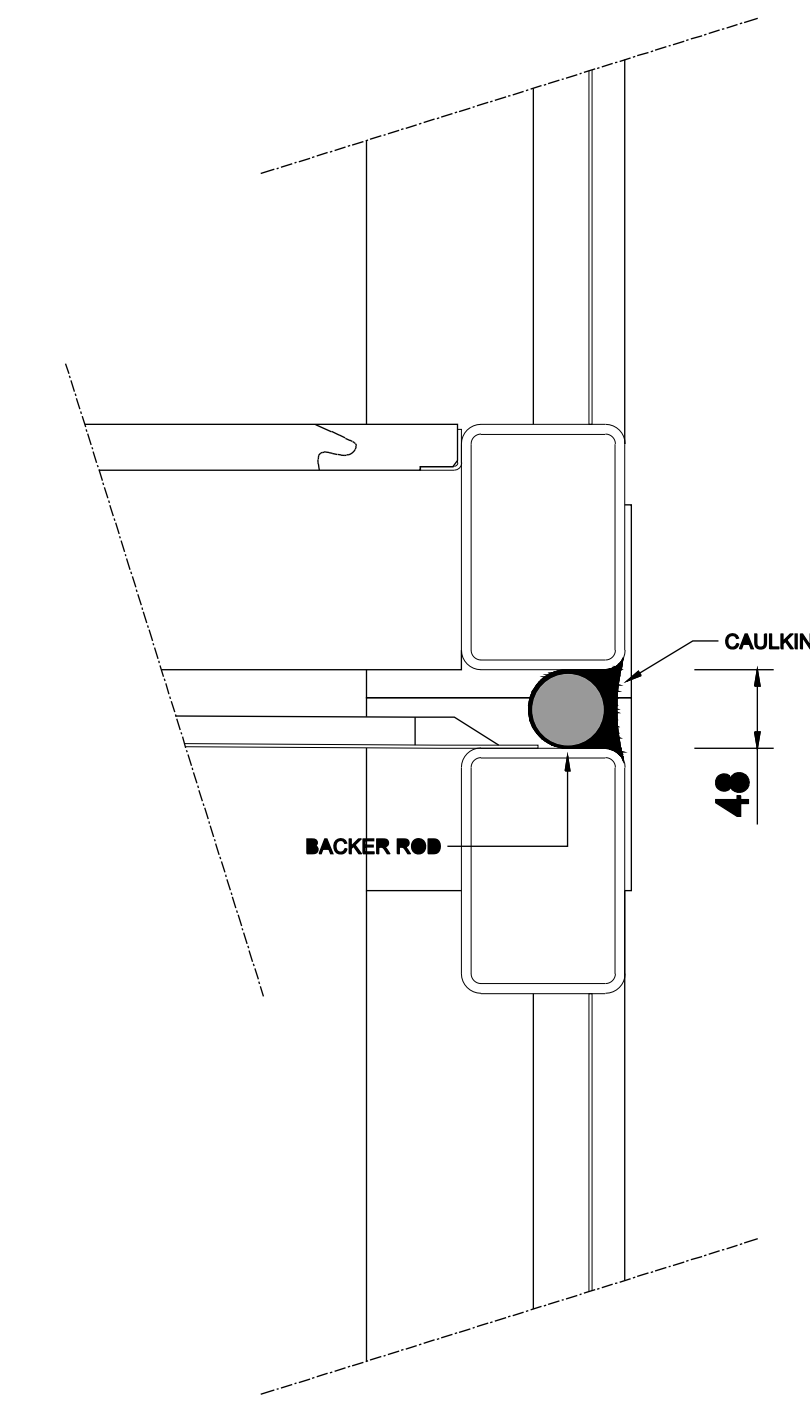

● SIDE VERTICAL DETAIL SECTION

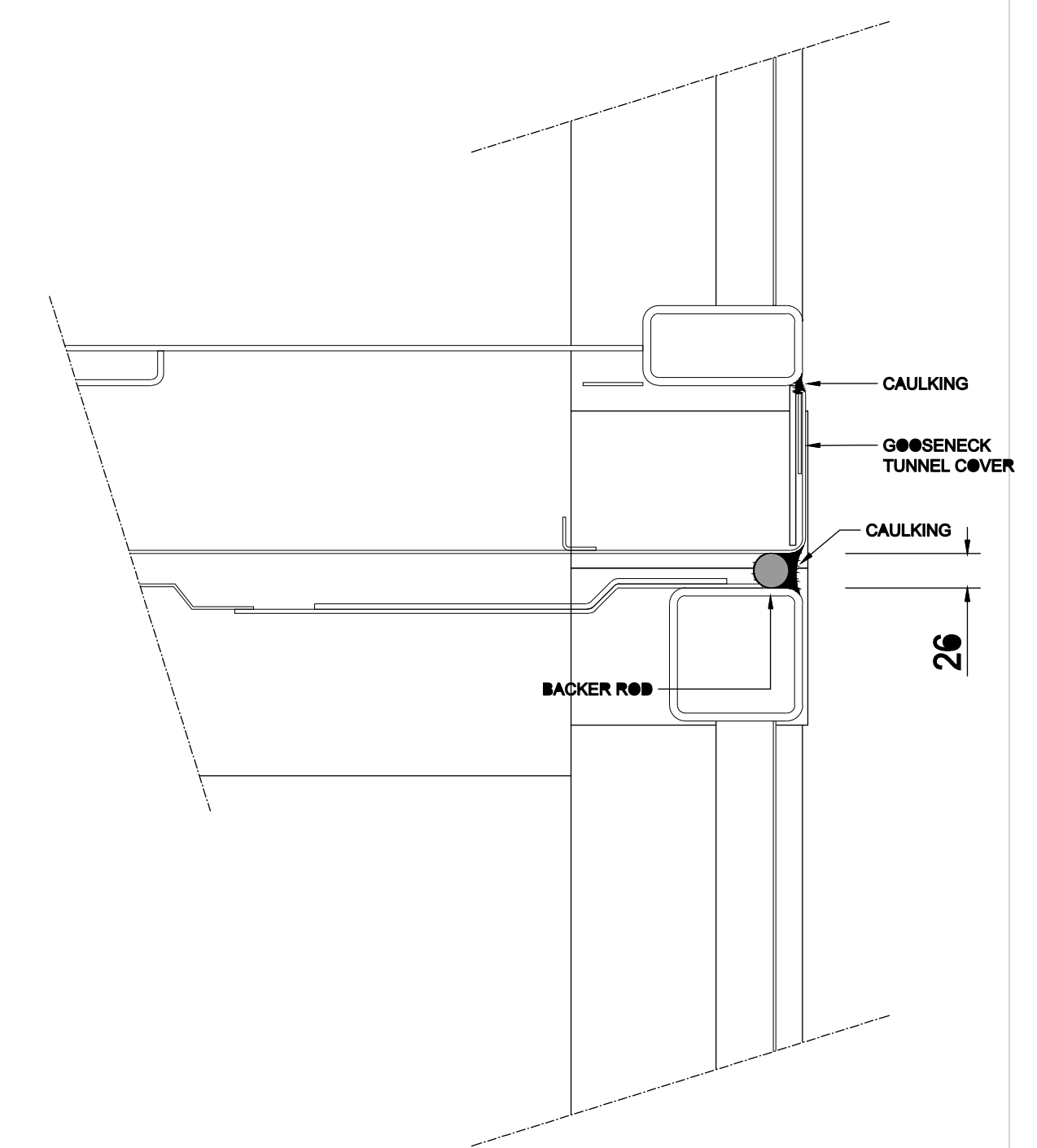

● FRONT END VERTICAL DETAIL SECTION

NOTE: The typical temperature for applying caulk must be above 43F (6C) and below 80F (26C), to ensure the caulk hardens correctly.

Windows & Exterior Doors Schedule

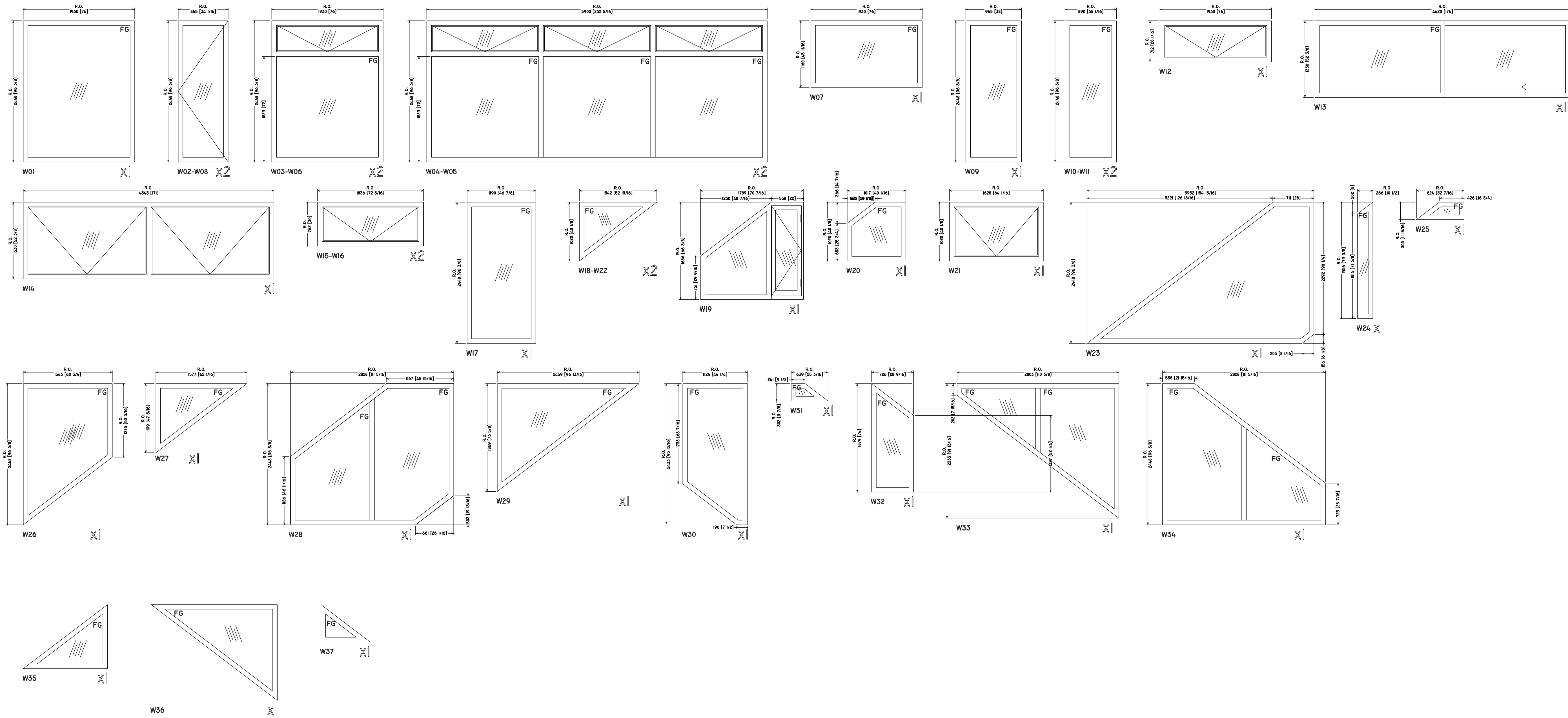

WINDOWS SCHEDULE						
#	QTY	DESCRIPTION	FRAME COLOUR	GLAZING	U-FACTOR	NOTES
W01	1	ALUM. FIX WINDOW	BLACK	DUAL PANE LOW E	0.28	
W02	1	ALUM. CASEMENT WINDOW	BLACK	DUAL PANE LOW E	0.28	
W03	1	ALUM. FIX + TILT WINDOW	BLACK	DUAL PANE LOW E	0.28	
W04	1	ALUM. FIX + TILT WINDOW	BLACK	DUAL PANE LOW E	0.28	
W05	1	ALUM. FIX + TILT WINDOW	BLACK	DUAL PANE LOW E	0.28	
W06	1	ALUM. FIX + TILT WINDOW	BLACK	DUAL PANE LOW E	0.28	
W07	1	ALUM. FIX WINDOW	BLACK	DUAL PANE LOW E	0.28	
W08	1	ALUM. CASEMENT WINDOW	BLACK	DUAL PANE LOW E	0.28	
W09	1	ALUM. FIX WINDOW	BLACK	DUAL PANE LOW E	0.28	
W10	1	ALUM. FIX WINDOW	BLACK	DUAL PANE LOW E	0.28	
W11	1	ALUM. FIX WINDOW	BLACK	DUAL PANE LOW E	0.28	
W12	1	ALUM. TILT WINDOW	BLACK	DUAL PANE LOW E	0.28	
W13	1	ALUM. SLIDING WINDOW	BLACK	DUAL PANE LOW E	0.28	
W14	1	ALUM. TILT WINDOW	BLACK	DUAL PANE LOW E	0.28	
W15	1	ALUM. TILT WINDOW	BLACK	DUAL PANE LOW E	0.28	

WINDOWS SCHEDULE						
#	QTY	DESCRIPTION	FRAME COLOUR	GLAZING	U-FACTOR	NOTES
W16	1	ALUM. TILT WINDOW	BLACK	DUAL PANE LOW E	0.28	
W17	1	ALUM. FIX WINDOW	BLACK	DUAL PANE LOW E	0.28	
W18	1	ALUM. FIX WINDOW	BLACK	DUAL PANE LOW E	0.28	
W19	1	ALUM. CAS. + FIX WINDOW	BLACK	DUAL PANE LOW E	0.28	
W20	1	ALUM. FIX WINDOW	BLACK	DUAL PANE LOW E	0.28	
W21	1	ALUM. TILT WINDOW	BLACK	DUAL PANE LOW E	0.28	
W22	1	ALUM. FIX WINDOW	BLACK	DUAL PANE LOW E	0.28	
W23	1	ALUM. FIX WINDOW	BLACK	DUAL PANE LOW E	0.28	
W24	1	ALUM. FIX WINDOW	BLACK	DUAL PANE LOW E	0.28	
W25	1	ALUM. FIX WINDOW	BLACK	DUAL PANE LOW E	0.28	
W26	1	ALUM. FIX WINDOW	BLACK	DUAL PANE LOW E	0.28	
W27	1	ALUM. FIX WINDOW	BLACK	DUAL PANE LOW E	0.28	
W28	1	ALUM. FIX WINDOW	BLACK	DUAL PANE LOW E	0.28	
W29	1	ALUM. FIX WINDOW	BLACK	DUAL PANE LOW E	0.28	
W30	1	ALUM. FIX WINDOW	BLACK	DUAL PANE LOW E	0.28	

WINDOWS SCHEDULE						
#	QTY	DESCRIPTION	FRAME COLOUR	GLAZING	U-FACTOR	NOTES
W31	1	ALUM. FIX WINDOW	BLACK	DUAL PANE LOW E	0.28	
W32	1	ALUM. FIX WINDOW	BLACK	DUAL PANE LOW E	0.28	
W33	1	ALUM. FIX WINDOW	BLACK	DUAL PANE LOW E	0.28	
W34	1	ALUM. FIX WINDOW	BLACK	DUAL PANE LOW E	0.28	
W35	1	ALUM. FIX WINDOW	BLACK	DUAL PANE LOW E	0.28	
W36	1	ALUM. FIX WINDOW	BLACK	DUAL PANE LOW E	0.28	
W37	1	ALUM. FIX WINDOW	BLACK	DUAL PANE LOW E	0.28	

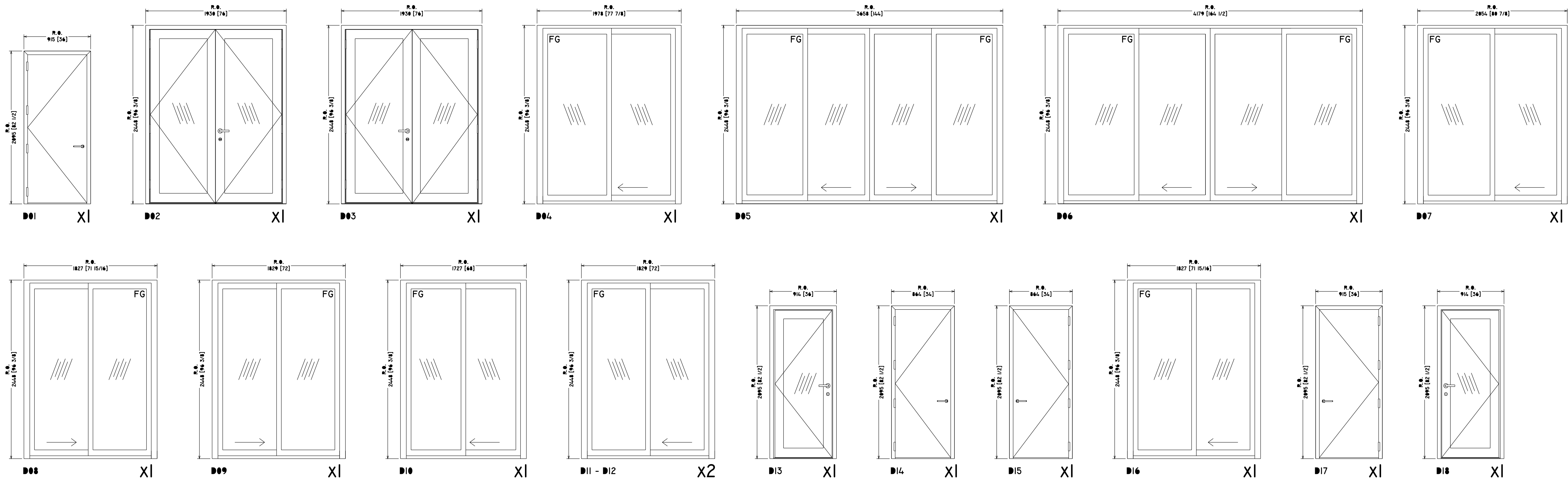

DOOR SCHEDULE						
#	QTY	DESCRIPTION	FRAME COLOR	GLAZING	U-FACTOR	NOTES
D01	1	STEEL DOOR	BLACK	DUAL PANE LOW E	0.58	
D02	1	ALUM. DOUBLE GLASS DOOR	BLACK	DUAL PANE LOW E	0.30	
D03	1	ALUM. DOUBLE GLASS DOOR	BLACK	DUAL PANE LOW E	0.30	
D04	1	ALUM. SLIDING GLASS DOOR	BLACK	DUAL PANE LOW E	0.30	
D05	1	ALUM. SLIDING GLASS DOOR	BLACK	DUAL PANE LOW E	0.30	
D06	1	ALUM. SLIDING GLASS DOOR	BLACK	DUAL PANE LOW E	0.30	
D07	1	ALUM. SLIDING GLASS DOOR	BLACK	DUAL PANE LOW E	0.30	
D08	1	ALUM. SLIDING GLASS DOOR	BLACK	DUAL PANE LOW E	0.30	
D09	1	ALUM. SLIDING GLASS DOOR	BLACK	DUAL PANE LOW E	0.30	
D10	1	ALUM. SLIDING GLASS DOOR	BLACK	DUAL PANE LOW E	0.30	
D11	1	ALUM. SLIDING GLASS DOOR	BLACK	DUAL PANE LOW E	0.30	
D12	1	ALUM. SLIDING GLASS DOOR	BLACK	DUAL PANE LOW E	0.30	
D13	1	ALUM. GLASS DOOR	BLACK	DUAL PANE LOW E	0.30	
D14	1	STEEL DOOR	BLACK	DUAL PANE LOW E	0.58	
D15	1	STEEL DOOR	BLACK	DUAL PANE LOW E	0.58	
D16	1	ALUM. SLIDING GLASS DOOR	BLACK	DUAL PANE LOW E	0.30	
D17	1	STEEL DOOR	BLACK	DUAL PANE LOW E	0.58	
D18	1	ALUM. GLASS DOOR	BLACK	DUAL PANE LOW E	0.30	

NE 1/4 OF SE 1/4 OF SECTION 7, TOWNSHIP 24N, RANGE 5E, WM

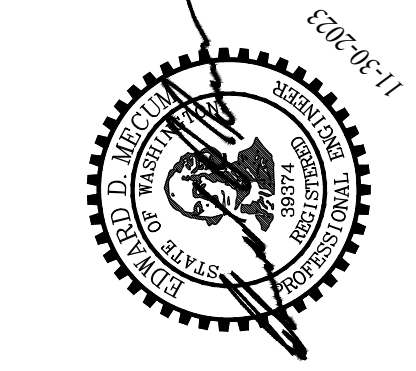
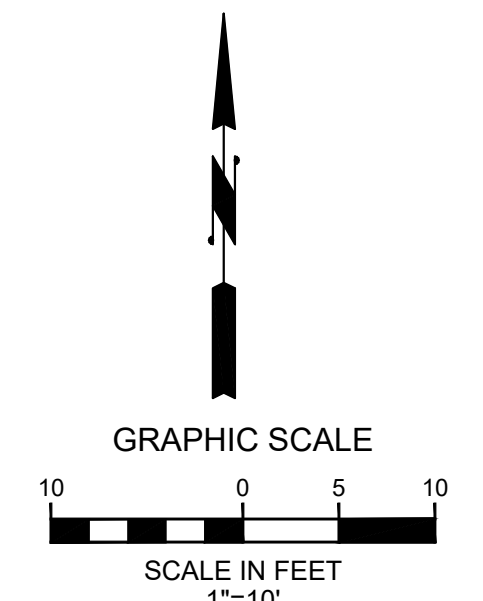
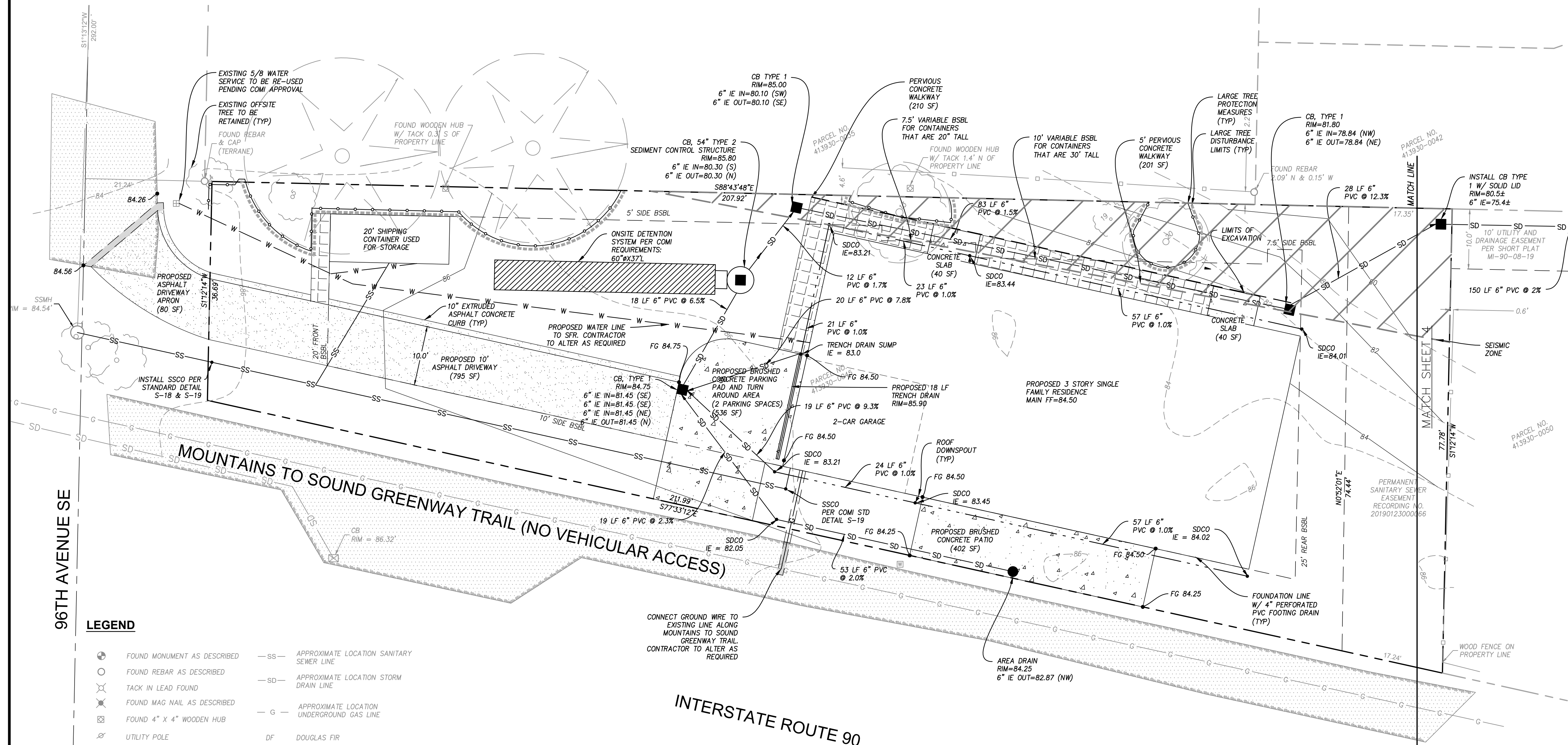

WATER NOTES

- 1-1" WATER SERVICE PER SD MI W-13. METER/SERVICE SIZE PER WATER SYSTEM BUILDING PLANS BY PLUMBING/MECHANICAL DESIGNER. CONSTRUCT OVERSIZE POLY PIPE OR PVC TO RESIDENCE TO ACCOMMODATE FLOW REQUIREMENTS (1-1/4" MINIMUM SIZE).
- SAWCUT, REMOVE & PATCH EXISTING PAVEMENT TO ORIGINAL CONDITION OR BETTER AT PRIVATE TRENCH PER COMI STANDARDS.
- RESTORE DISTURBED LANDSCAPE AREAS TO PRE-EXISTING CONDITION OR BETTER TO THE SATISFACTION OF THE PROPERTY OWNER.
- EXISTING WATER SERVICE LINES ARE LOCATED WITHIN THE IMMEDIATE AREA OF WORK. CONTRACTOR RESPONSIBLE TO COORDINATE ANY SHUT-DOWNS WITH ADJACENT PROPERTIES. REPAIR ANY SERVICE LINES DAMAGED TO ORIGINAL CONDITION OR BETTER.

SANITARY SEWER NOTES

- CONNECT NEW 6" SIDE SEWER TO EXISTING SANITARY SEWER SYSTEM PER COMI STANDARDS. VERIFY LOCATION & INVERTS.
- SAWCUT, REMOVE & PATCH EXISTING PAVEMENT PER CITY OF MERCER ISLAND REQUIREMENTS IN RIGHT-OF-WAY AT TRENCH CROSSING PER COMI STANDARDS.
- SSCO PER SD MI S-19 W/ TRAFFIC RATED LID.
- SSCO PER SD MI S-19 W/ PVC CAP 6" ABOVE FINISH GRADE.
- CONSTRUCT TEMP. CAP FOR FUTURE BUILDING CONNECTION.
- CONSTRUCT 6" SANITARY SIDE SEWER AT S=0.0200' PER MINIMUM TO BUILDING. SEE SANITARY SEWER SYSTEM BUILDING PLANS BY PLUMBING DESIGNER CONFIRM LOCATION W/ ARCHITECT.
- SAWCUT, REMOVE & PATCH EXISTING PAVEMENT TO ORIGINAL CONDITION OR BETTER PER COMI STANDARDS.
- EXISTING GAS LINE IN WORK AREA. CONTRACTOR TO COORDINATE CONSTRUCTION OF SANITARY SIDE SEWER & PROTECT GAS LINE FROM ANY DAMAGE.

STORM DRAIN GENERAL NOTES

- A PRE-CONSTRUCTION CONFERENCE SHALL BE HELD PRIOR TO THE START OF CONSTRUCTION. THE CONTRACTOR SHALL BE RESPONSIBLE FOR SECURING ALL NECESSARY PERMITS PRIOR TO CONSTRUCTION.
- BEFORE ANY CONSTRUCTION MAY OCCUR, THE CONTRACTOR SHALL HAVE PLANS WHICH HAVE BEEN SIGNED AND APPROVED BY THE CITY OF MERCER ISLAND PUBLIC WORKS DEPARTMENT, OBTAINED ALL CITY, COUNTY, STATE, FEDERAL AND OTHER REQUIRED PERMITS, AND HAVE POSTED ALL REQUIRED BONDS.
- ALL STORM DRAINAGE IMPROVEMENTS SHALL BE DESIGNED AND CONSTRUCTED IN ACCORDANCE WITH THE LATEST EDITION OF THE CITY OF MERCER ISLAND PUBLIC WORKS PRE-APPROVED PLANS AND POLICIES AND THE STANDARD SPECIFICATIONS FOR ROAD, BRIDGE AND MUNICIPAL CONSTRUCTION, PREPARED BY WSDOT AND THE AMERICAN PUBLIC WORKS ASSOCIATION (APWA).
- ANY DEVIATION FROM THE APPROVED PLANS WILL REQUIRE WRITTEN APPROVAL, ALL CHANGES SHALL BE SUBMITTED TO THE CITY.
- A COPY OF THE APPROVED STORM WATER PLANS MUST BE ON THE JOB SITE WHENEVER CONSTRUCTION IS IN PROGRESS.
- ALL DISTURBED AREAS SHALL BE SEEDED AND MULCHED OR SIMILARLY STABILIZED TO THE SATISFACTION OF THE CITY OF MERCER ISLAND DEPARTMENT OF PUBLIC WORKS FOR THE PREVENTION OF ON-SITE EROSION AFTER THE COMPLETION OF CONSTRUCTION.
- MINIMUM COVER OVER STORM DRAINAGE PIPES IN ROW OR VEHICULAR PATH SHALL BE 18 INCHES, UNLESS OTHER DESIGN IS APPROVED.
- CONSTRUCTION OF DEWATERING (GROUNDWATER) SYSTEMS SHALL BE IN ACCORDANCE WITH THE APWA STANDARD SPECIFICATIONS.
- ALL TRENCH BACKFILL SHALL BE COMPACTED TO 95 PERCENT DENSITY IN ROADWAYS, ROADWAY SHOULDERS, ROADWAY PRISM AND DRIVEWAYS, AND 85 PERCENT DENSITY IN UNPAVED AREAS. ALL PIPE ZONE COMPACTON SHALL BE 95 PERCENT.
- THE CONTRACTOR SHALL BE RESPONSIBLE FOR PROVIDING ADEQUATE SAFEGUARDS, SAFETY DEVICES, PROTECTIVE EQUIPMENT, CONFINED SPACE PROTECTION, FLAGGERS, AND ANY OTHER NEEDED ACTIONS TO PROTECT THE LIFE, HEALTH, AND SAFETY OF THE PUBLIC, AND TO PROTECT PROPERTY IN CONNECTION WITH THE PERFORMANCE OF WORK COVERED BY THE CONTRACT.
- APPROXIMATE LOCATIONS OF EXISTING UTILITIES HAVE BEEN OBTAINED FROM AVAILABLE RECORDS AND ARE SHOWN FOR CONVENIENCE. THE CONTRACTOR SHALL BE RESPONSIBLE FOR VERIFICATION OF EXISTING UTILITY LOCATIONS WHETHER OR NOT THESE UTILITIES ARE SHOWN ON THE PLANS. THE CONTRACTOR SHALL EXERCISE ALL CARE TO AVOID DAMAGE TO ANY UTILITY. IF CONFLICTS WITH EXISTING UTILITIES ARISE DURING CONSTRUCTION, THE CONTRACTOR SHALL NOTIFY THE CITY CONSTRUCTION INSPECTOR AND ANY CHANGES REQUIRED SHALL BE APPROVED BY THE DEVELOPMENT ENGINEER PRIOR TO COMMENCEMENT OF RELATED CONSTRUCTION ON THE PROJECT.
- THE UNDERGROUND UTILITY LOCATION SERVICE SHALL BE CONTACTED FOR FIELD LOCATION OF EXISTING UTILITIES PRIOR TO ANY CONSTRUCTION. THE OWNER OR HIS REPRESENTATIVE SHALL BE CONTACTED IF A UTILITY CONFLICT EXISTS. FOR UTILITY LOCATION IN KING COUNTY, CALL 811. THE CONTRACTOR IS RESPONSIBLE TO ENSURE THAT UTILITY LOCATES ARE MAINTAINED THROUGHOUT THE LIFE OF THE PROJECT.
- OPEN CUT ROAD CROSSINGS FOR UTILITY TRENCHES ON EXISTING TRAVELED ROADWAY SHALL BE BACKFILLED ONLY WITH 5/8" MINUS CRUSHED ROCK AND MECHANICALLY COMPACTED (UNLESS OTHERWISE APPROVED BY THE CITY). CUTS INTO THE EXISTING ASPHALT SHALL BE NEAT LINE CUT WITH SAW OR JACKHAMMER IN A CONTINUOUS LINE. A TEMPORARY COLD MIX PATCH MUST BE PLACED IMMEDIATELY AFTER BACKFILL AND COMPACTION. A PERMANENT HOT MIX PATCH SHALL BE PLACED WITHIN 30 DAYS AND SHALL BE A MINIMUM OF 1" THICKER THAN THE ORIGINAL ASPHALT WITH A MINIMUM THICKNESS OF 2".
- ALL DAMAGES INCURRED TO PUBLIC AND/OR PRIVATE PROPERTY BY THE CONTRACTOR DURING THE COURSE OF CONSTRUCTION SHALL BE PROMPTLY REPAIRED TO THE SATISFACTION OF THE CITY CONSTRUCTION INSPECTOR BEFORE PROJECT APPROVAL AND/OR THE RELEASE OF THE PROJECTS PERFORMANCE BOND.
- GROUT ALL SEAMS AND OPENINGS IN ALL INLETS, CATCH BASINS, AND MANHOLES.

SITE IMPROVEMENT NOTES

- PROOF OF LIABILITY INSURANCE SHALL BE SUBMITTED TO THE CITY PRIOR TO THE PRE-CONSTRUCTION MEETING.
- THESE PLANS ARE APPROVED FOR GRADING, DRAINAGE, AND UTILITY IMPROVEMENTS ONLY. PLANS FOR STRUCTURES REQUIRE A SEPARATE REVIEW AND APPROVAL.
- RETAINING WALLS GREATER THAN FOUR (4) FEET IN HEIGHT REQUIRE A SEPARATE BUILDING PERMIT.
- FILL MATERIAL PLACED UNDER BUILDING FOUNDATIONS OR PAVEMENT SHALL BE CRUSHED BASE ROCK OR COMPACTED STRUCTURAL FILL IN ACCORDANCE WITH CITY AND WSDOT STANDARD SPECIFICATIONS.
- ALL DRAINAGE STRUCTURES, SUCH AS CATCH BASINS AND MANHOLES, NOT LOCATED WITHIN A TRAVELED ROADWAY OR SIDEWALK, SHALL HAVE SOLID LOCKING LIDS.
- THIS PLAN DOES NOT SHOW THE LOCATION OF ALL EXISTING UTILITIES. IT IS THE RESPONSIBILITY OF THE CONTRACTOR TO LOCATE ALL EXISTING UTILITIES PRIOR TO EXCAVATION.
- THE CONTRACTOR SHALL EXPOSE ALL EXISTING PIPING THAT WILL BE CONNECTED TO WITH NEW PIPING. DEPTH, LOCATION, AND CONDITION SHALL BE RELAYED TO THE ENGINEER IF CONDITIONS VARY SIGNIFICANTLY FROM WHAT IS DETAILED OR ANTICIPATED.
- ALL WORK SHALL BE PERFORMED IN STRICT ACCORDANCE TO DETAILS AND SPECIFICATIONS OF CITY STANDARDS. ALL CONSTRUCTION DEBRIS GENERATED DURING CONSTRUCTION TO BE REMOVED & DISPOSED OF AT AN APPROVED LOCATION OFF-SITE.
- ALL CUT MATERIAL GENERATED DURING THE PROJECT THAT IS NOT ACCEPTABLE FOR USE AS COMPACTED FILL MATERIAL AT ANOTHER LOCATION ON-SITE MUST BE HAULED TO AN APPROVED LOCATION OFF-SITE.

ARCHITECTURAL & STRUCTURAL NOTES

- THESE PLANS ARE APPROVED FOR STANDARD ROAD AND DRAINAGE IMPROVEMENTS ONLY. PLANS FOR STRUCTURES SUCH AS RETAINING WALLS REQUIRE A SEPARATE REVIEW AND APPROVAL PRIOR TO CONSTRUCTION.
- SPECIAL INSPECTIONS FOR STRUCTURAL ASPECTS OF OF THE PROJECT MAY BE REQUIRED DURING VARIOUS STAGES OF THE PROJECT. CONTRACTOR TO BE RESPONSIBLE FOR COORDINATION AND OBTAINING INSPECTIONS WHEN AND WHERE NECESSARY.
- SEE ARCHITECTURAL PLANS FOR BUILDING SECTIONS AND ALL LOCATIONAL/DIMENSIONAL ASPECTS OF BUILDINGS.
- SEE ARCHITECTURAL AND STRUCTURAL PLANS FOR ALL BUILDING AND RETAINING WALL DETAILS.
- COORDINATE ALL SITE CIVIL CONSTRUCTION WITH ARCHITECTURAL, STRUCTURAL, MECHANICAL/PLUMBING AND LANDSCAPE PLANS

AMENDMENT SOIL NOTE

THE LAWN AND LANDSCAPE AREAS ARE REQUIRED TO PROVIDE POST-CONSTRUCTION SOIL DEPTH AND QUALITY REQUIREMENTS (SHT 2). FINAL INSPECTION OF SOIL WILL BE REQUIRED TO VERIFY DEPTH, ORGANIC CONTENT. PHOTOS TO BE TAKEN DURING CONSTRUCTION SHOWING UNDERLYING SOIL SCARIFIED TO 12" DEPTH

SOIL AMENDMENT NOTE

THE LAWN AND LANDSCAPE AREAS ARE REQUIRED TO PROVIDE POST-CONSTRUCTION SOIL QUALITY AND DEPTH IN ACCORDANCE WITH BMP 15.13. THE PROJECT GEOTECHNICAL ENGINEER MUST PROVIDE A LETTER OF CERTIFICATION TO ENSURE THAT THE LAWN AND LANDSCAPE AREAS ARE MEETING THE POST CONSTRUCTION SOIL QUALITY AND DEPTH REQUIREMENT SPECIFIED ON THE APPROVED PLAN SET PRIOR TO FINAL INSPECTION OF THE PROJECT.

STORM DRAINAGE NOTES

- CATCH BASIN, 48" TYPE 2 WSDOT SD 8-10.20-02 W/ SOLID ROUND LOCKING LID. LOCATE ON EXISTING 12" CP.
- SSCO PER SD MI S-19 W/ TRAFFIC RATED LID.
- SSCO PER SD MI S-19 W/ PVC CAP 6" ABOVE FINISH GRADE.
- CONSTRUCT 4" PER. PVC FOOTING DRAIN.
- CATCH BASIN TYPE 2-54" W/ SOL. LOCKING LID & RESTRICTOR PER CITY OF MERCER ISLAND ON-SITE DETENTION SYSTEM WORKSHEET DETAIL SEE DETENTION SYSTEM WORKSHEET, PLAN & PROFILES SHEETS 3 & 4.
- CONSTRUCT 6" PVC OUTFALL STORM DRAIN SYSTEM.
- CONNECT FOOTING DRAIN TO TIGHTLINE TO OUTFALL STORM SYSTEM 1' MIN. LOWER THAN LOWEST FOOTING DRAIN.
- CONSTRUCT 6" PVC ROOF DRAIN COLLECTOR @ S=1.00% MIN.
- PRIVATE YARD/AREA DRAIN SEE DETAIL SHEET 5.
- DOWNSPOUTS PER ARCHITECT'S PLANS.
- FOOTING DRAIN NOT TO BE CONNECTED TO DETENTION SYSTEM.
- STORM DRAIN CLEANOUT 100 FEET MAXIMUM BETWEEN CLEANOUTS.
- PROVIDE DIP PIPE SLEEVE FOR PENETRATIONS THROUGH WALLS AS REQUIRED. COORDINATE LOCATIONS W/ STRUCTURAL PLANS. SLEEVE TO BE ONE PIPE SIZE LARGER THAN DESIGN PIPING SIZE (O.D.).
- SAWCUT, REMOVE & PATCH EXISTING PAVEMENT PER CITY OF MERCER ISLAND REQUIREMENTS IN RIGHT-OF-WAY AT TRENCH CROSSING PER COMI STANDARDS.
- SAWCUT, REMOVE & PATCH EXISTING PAVEMENT TO ORIGINAL CONDITION OR BETTER PER COMI STANDARDS.
- 6" PVC ROOF/AREA DRAIN PIPING TO CONNECT TO ROOF DRAIN COLLECTOR
- ADJACENT LOT IS OWNED BY THE SAME OWNER AND 15' STORM & SEWER EASEMENT WILL BE PROVIDED WITH THE NEXT SUBMITTAL

SPECIAL CONTRACTOR NOTES

CONTRACTOR TO INSURE THAT THE FINAL DRIVEWAY GRADE AND CATCH BASIN/YARD DRAIN ELEVATIONS ARE CONSTRUCTED TO RESTRICT ANY STORM DRAINAGE FROM LEAVING THE DRIVEWAY SURFACE.

RETAINING WALL NOTES

ALL WALL DESIGN, REINFORCEMENT, WATERPROOFING, AND RETAINING WALL DRAINAGE CONTROL PER STRUCTURAL AND ARCHITECTURAL PLANS AND SPECIFICATIONS. INSTALL 36" HANDRAILING AS NECESSARY WHERE WALLS EXCEED 30" IN HEIGHT SEE ARCHITECT'S PLANS.

WORK WITHIN EXISTING TREE

ALL TRENCHES THAT ARE EXCAVATED WITHIN TREE DRIP LINES SHALL BE EXCAVATED WITH AN AIR SPADE SO THAT UTILITY LINES CAN BE INSTALLED WITHOUT CUTTING MAJOR ROOTS. ROOTS EXPOSED IN OPEN TRENCHES MUST BE KEPT MOIST BY BEING COVERED WITH MOISTENED BURLAP UNTIL THE TRENCH CAN BE CLOSED.

SOIL AMENDMENT NOTE

THE LAWN AND LANDSCAPE AREAS ARE REQUIRED TO PROVIDE POST-CONSTRUCTION SOIL QUALITY AND DEPTH IN ACCORDANCE WITH BMP 15.13. THE PROJECT GEOTECHNICAL ENGINEER MUST PROVIDE A LETTER OF CERTIFICATION TO ENSURE THAT THE LAWN AND LANDSCAPE AREAS ARE MEETING THE POST CONSTRUCTION SOIL QUALITY AND DEPTH REQUIREMENT SPECIFIED ON THE APPROVED PLAN SET PRIOR TO FINAL INSPECTION OF THE PROJECT.

TRENCH EXCAVATION NOTES

ALL SEWER AND DRAINAGE PIPES SHALL BE BACKFILLED TO 95% MDD (INTENT: TO RESTRICT SUBSURFACE DRAINAGE FROM TRAVELING ALONG THE PIPE BARREL).

SITE IMPROVEMENT NOTES

- PROVIDE SMOOTH TRANSITION FROM EXISTING IMPROVEMENTS TO NEW IMPROVEMENTS.
- CONSTRUCT DRIVEWAY SECTION PER DETAIL SHEET 5. FINISH, TEXTURE, JOINTS, REINF. ETC. PER ARCHITECTS & STRUCTURAL PLANS.
- RETAINING WALLS, AT LOCATIONS SHOWN, FINISH, TEXTURE, JOINTS, REINF. ETC. PER ARCHITECTS & STRUCTURAL PLANS. SEPARATE BUILDING PERMIT REQUIRED IF GREATER THAN 4' HIGH.
- CONSTRUCT MODULAR LANDSCAPE RETAINING WALLS ADJACENT TO BUILDING PER MANUFACTURER REQT'S. PERMIT REQUIRED IF GREATER THAN 4' HIGH.
- SEE LANDSCAPING PLAN BY OTHERS FOR LANDSCAPE.
- SEE ILLUMINATION PLAN BY OTHERS FOR LANDSCAPE LIGHTING & ASSOCIATED APPURTENANCES.
- REFUSE / RECYCLE AREA PER ARCHITECTS PLANS.
- FLOWLINE OF DRIVEWAY PAVEMENT, TYP.
- DECKS, CATWALKS, STEPS AS SHOWN. MATERIAL, FINISH, TEXTURE, ETC. PER ARCHITECTS & STRUCTURAL PLANS.

LEGEND

- FOUND MONUMENT AS DESCRIBED
- FOUND REBAR AS DESCRIBED
- TACK IN LEAD FOUND
- FOUND MAG NAIL AS DESCRIBED
- FOUND 4" X 4" WOODEN HUB
- UTILITY POLE
- SANITARY SEWER MANHOLE
- WATER VALVE
- FIRE HYDRANT
- WATER METER
- CATCH BASIN
- WATER HANDHOLE
- APPROXIMATE LOCATION SANITARY SEWER LINE
- APPROXIMATE LOCATION STORM DRAIN LINE
- APPROXIMATE LOCATION UNDERGROUND GAS LINE
- DOUGLAS FIR
- DECIDUOUS
- MAPLE
- * INDICATES MULTI-TRUNK
- WOOD FENCE



DATE	CHG BY	NOTES
11-30-2023	EDM	SUBMITTED TO CLIENT
	WJR	

1700 NW GILMAN BLVD, STE 200
ISSAQUAH, WA 98027
PHONE: (425) 821-5038
CIVIL

APN: 413930-0045
SITE DEVELOPMENT PLAN
ADAMS SFR
MERCER ISLAND, WA
SAMUEL ADAMS
26122
MERCER ISLAND, WA

APPROVED: CITY OF MERCER ISLAND DEVELOPMENT SERVICES GROUP

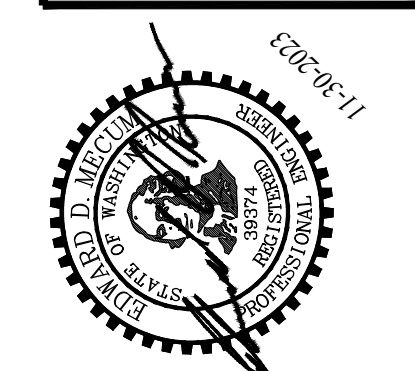
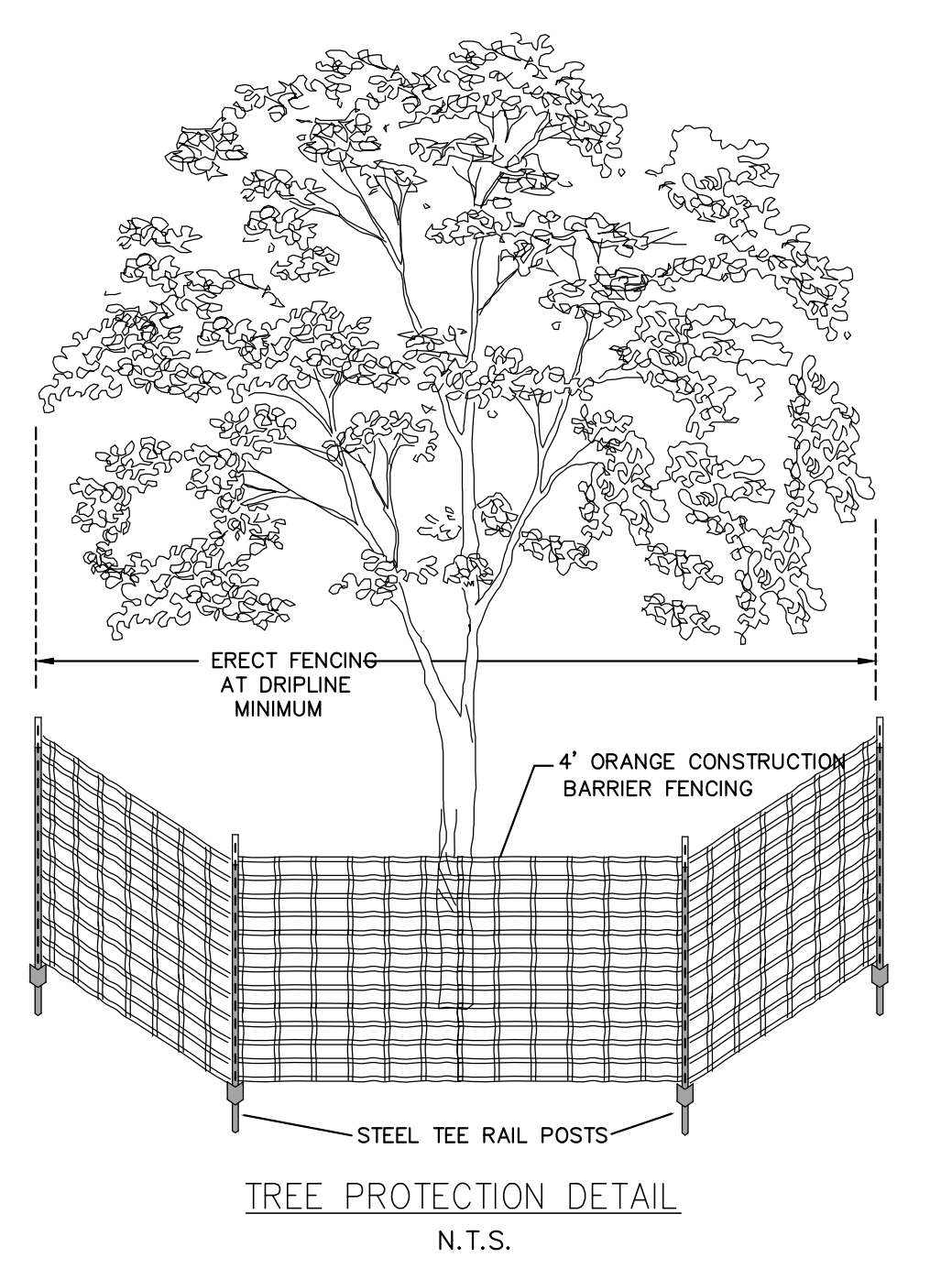
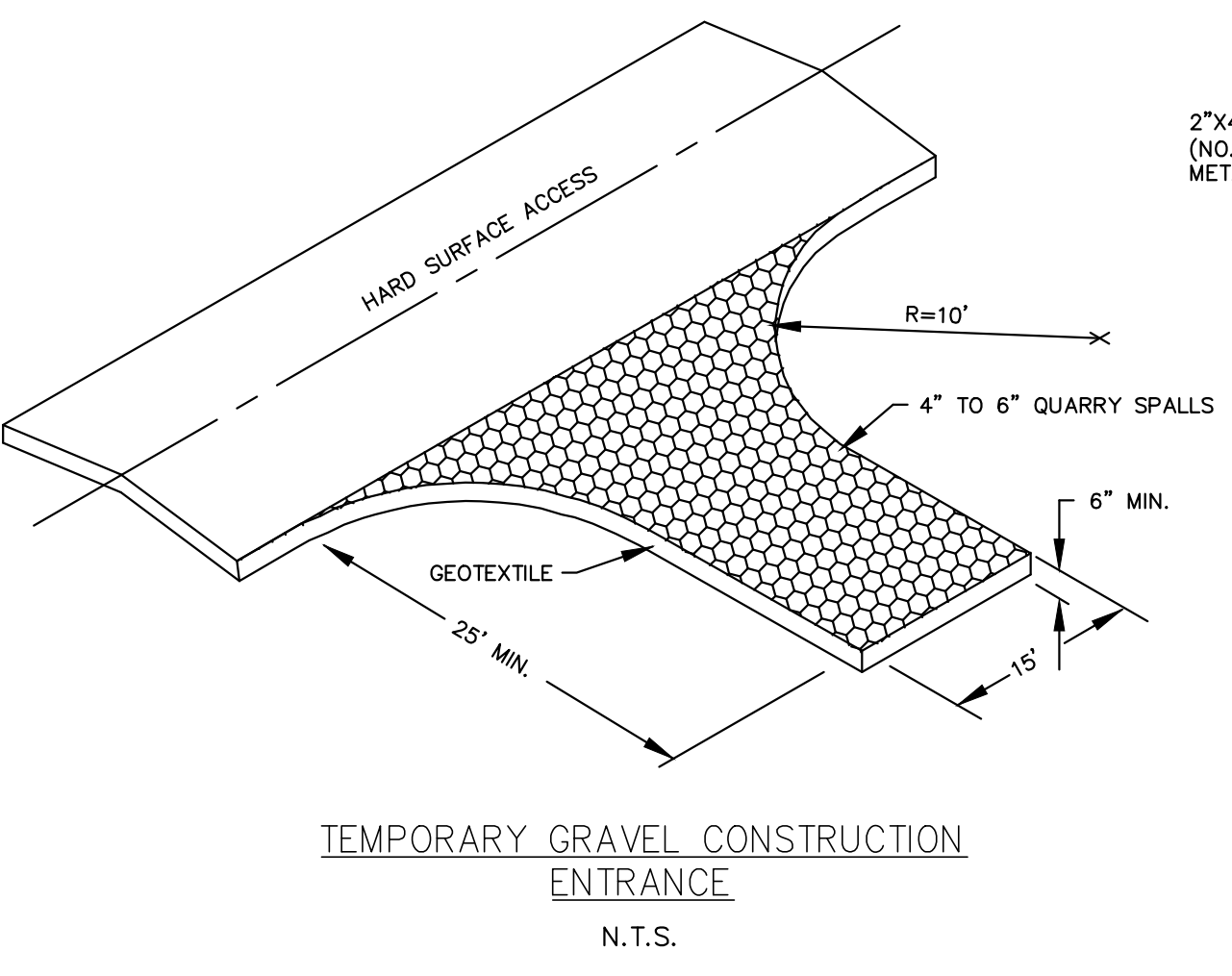
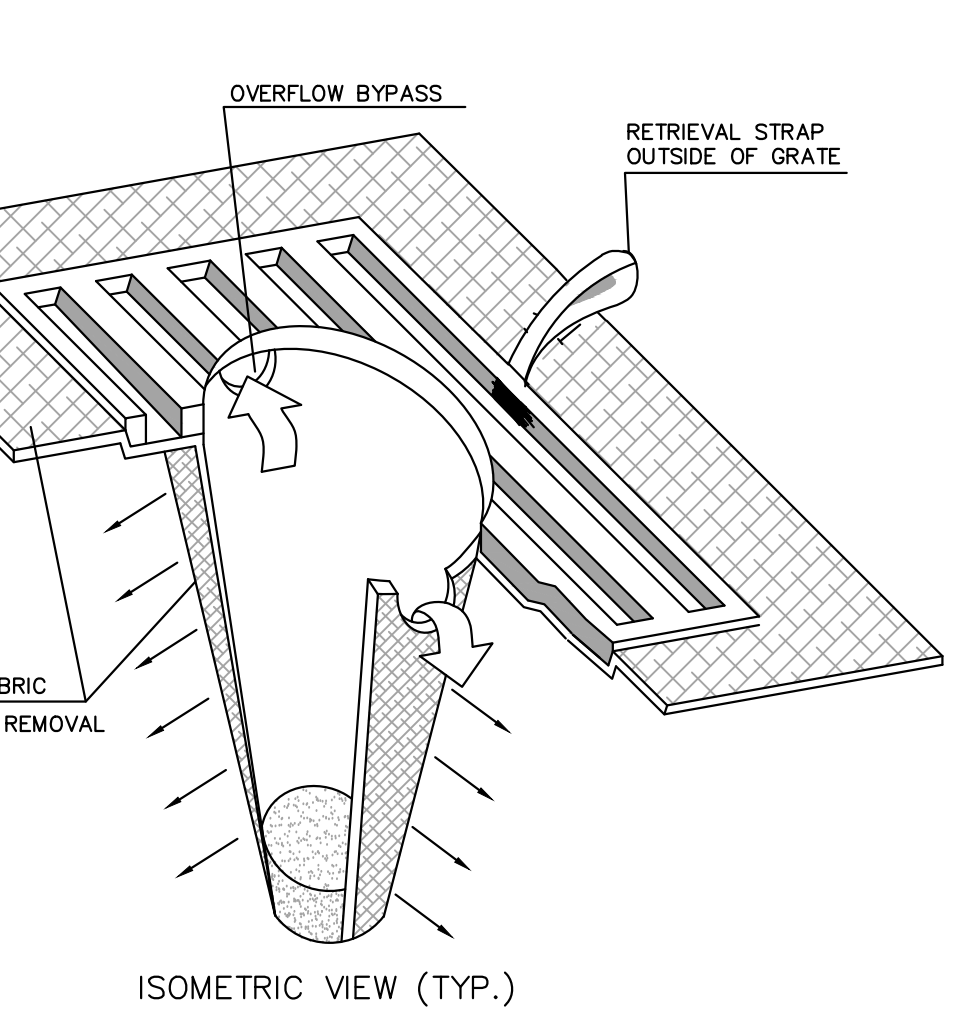
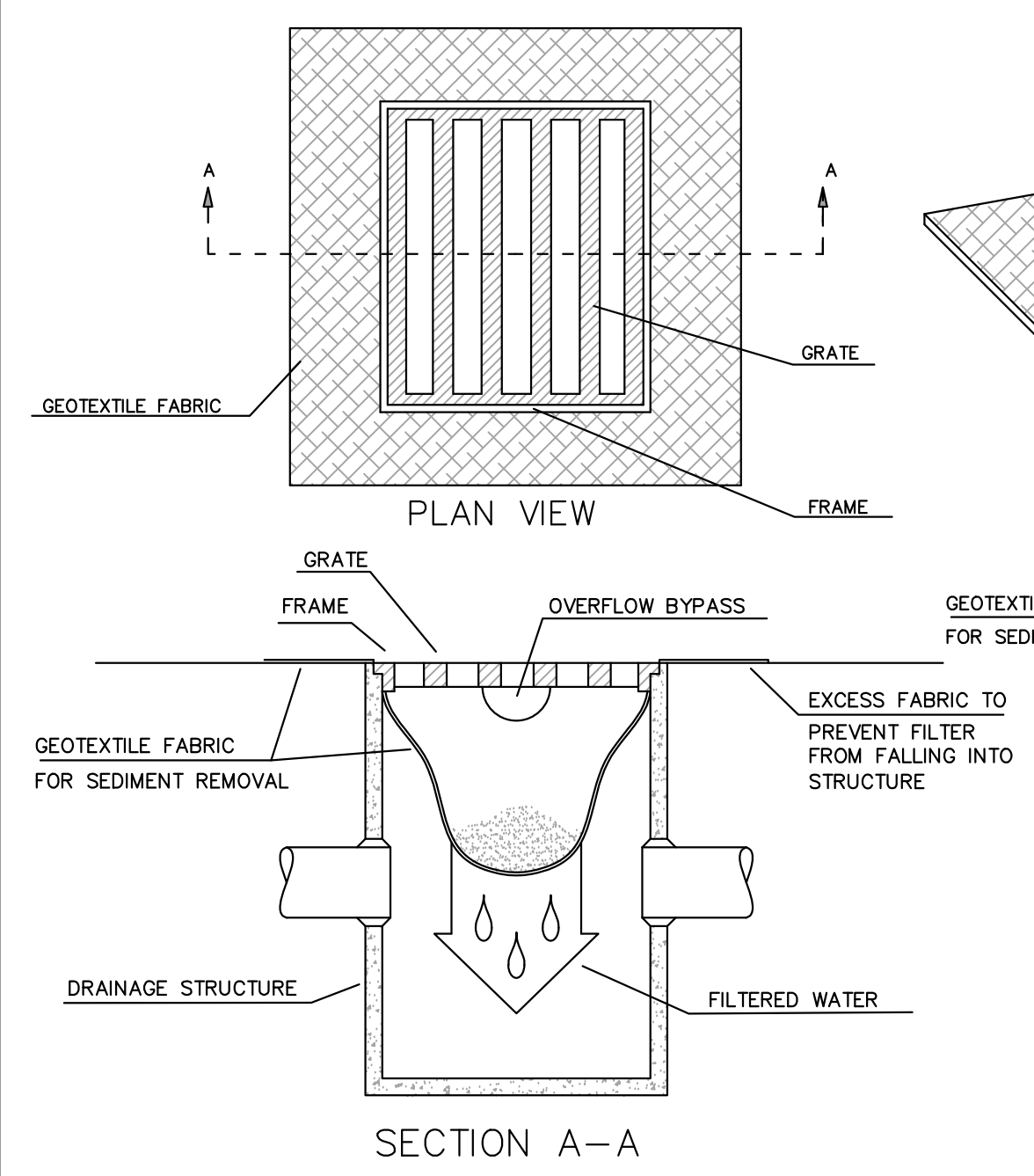
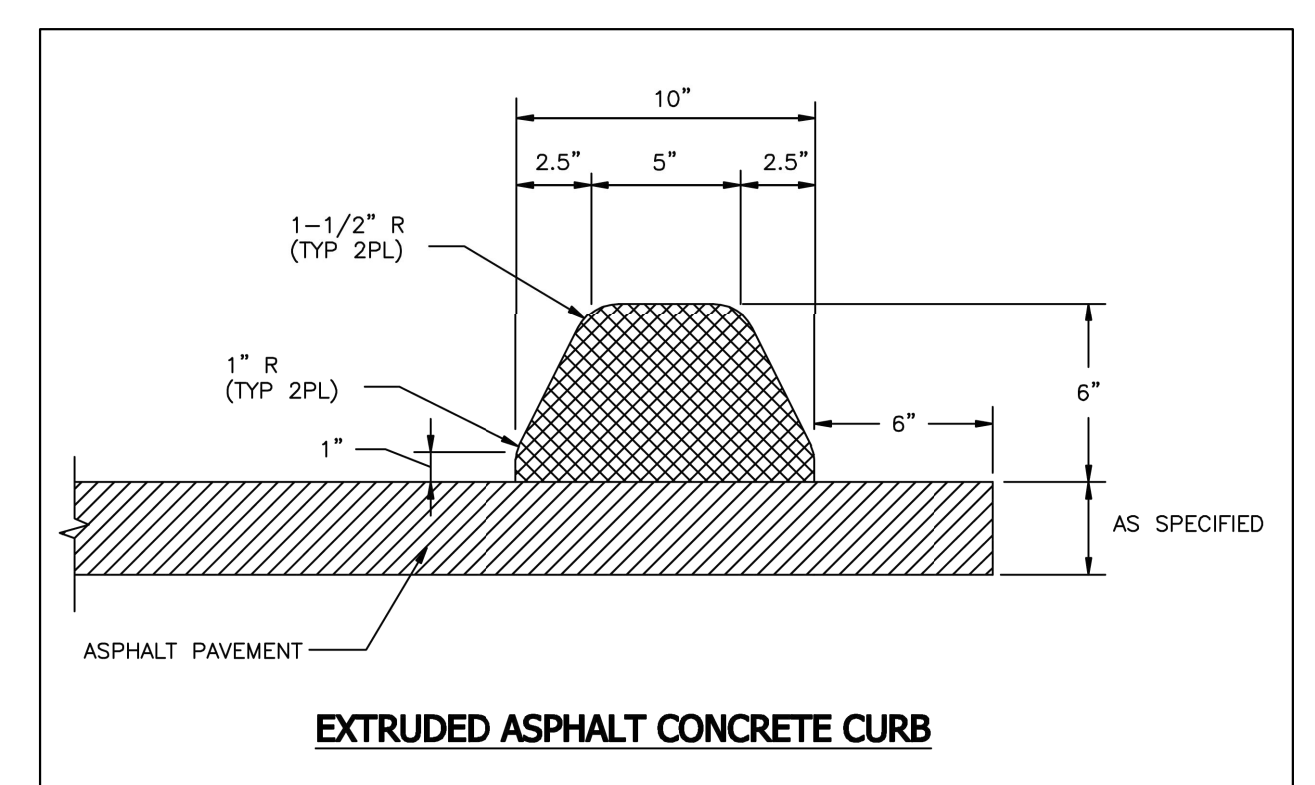
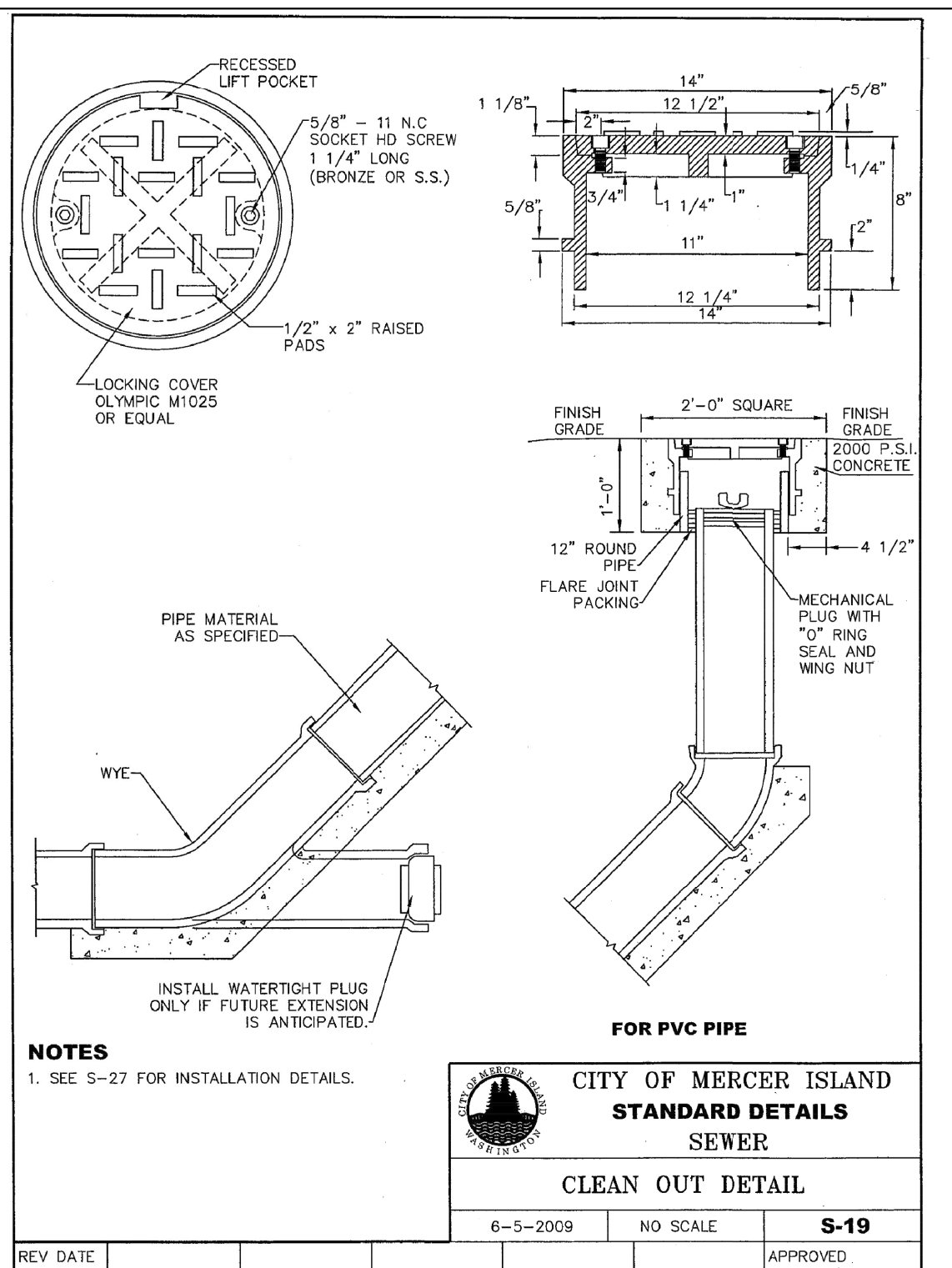
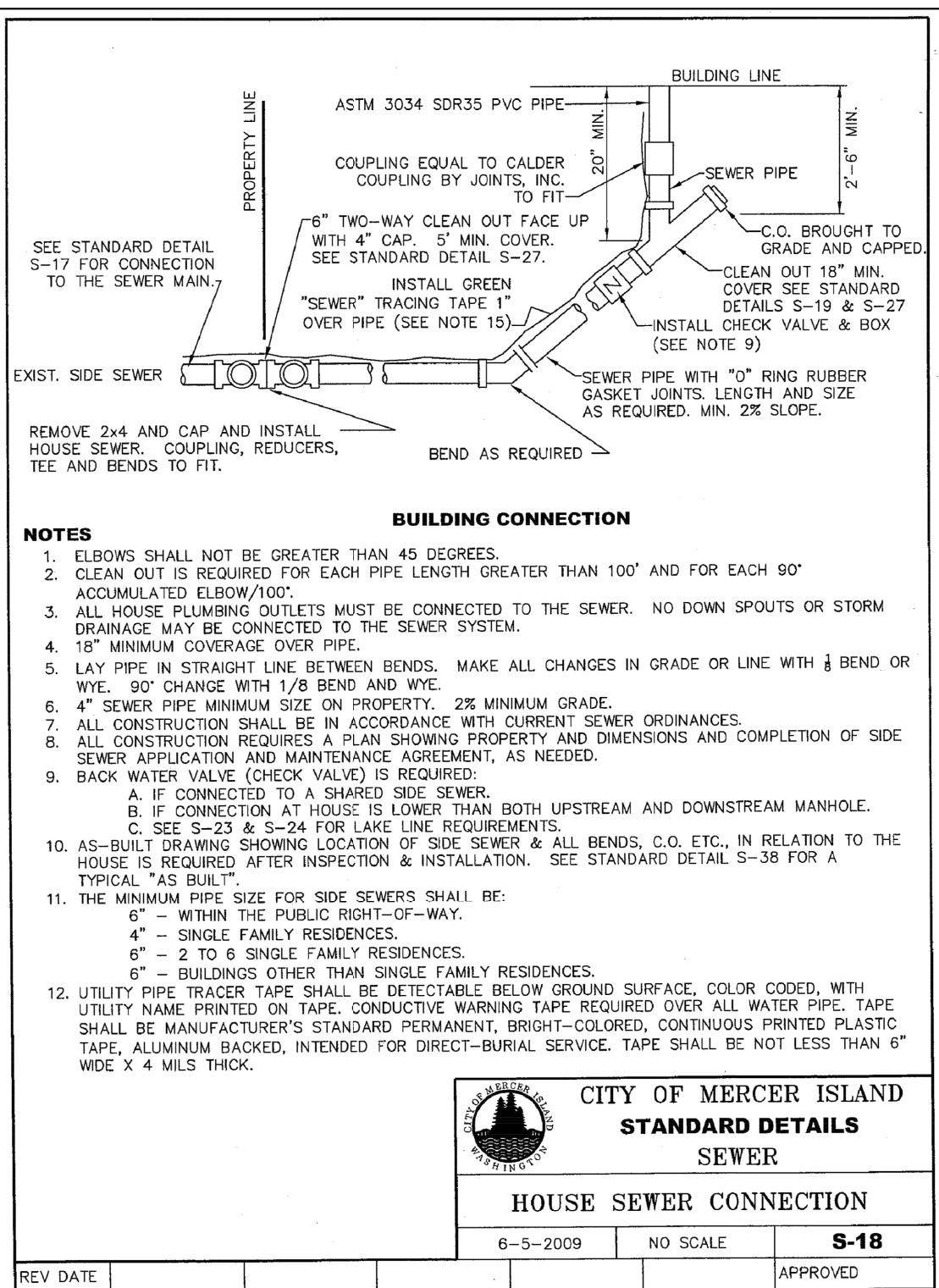
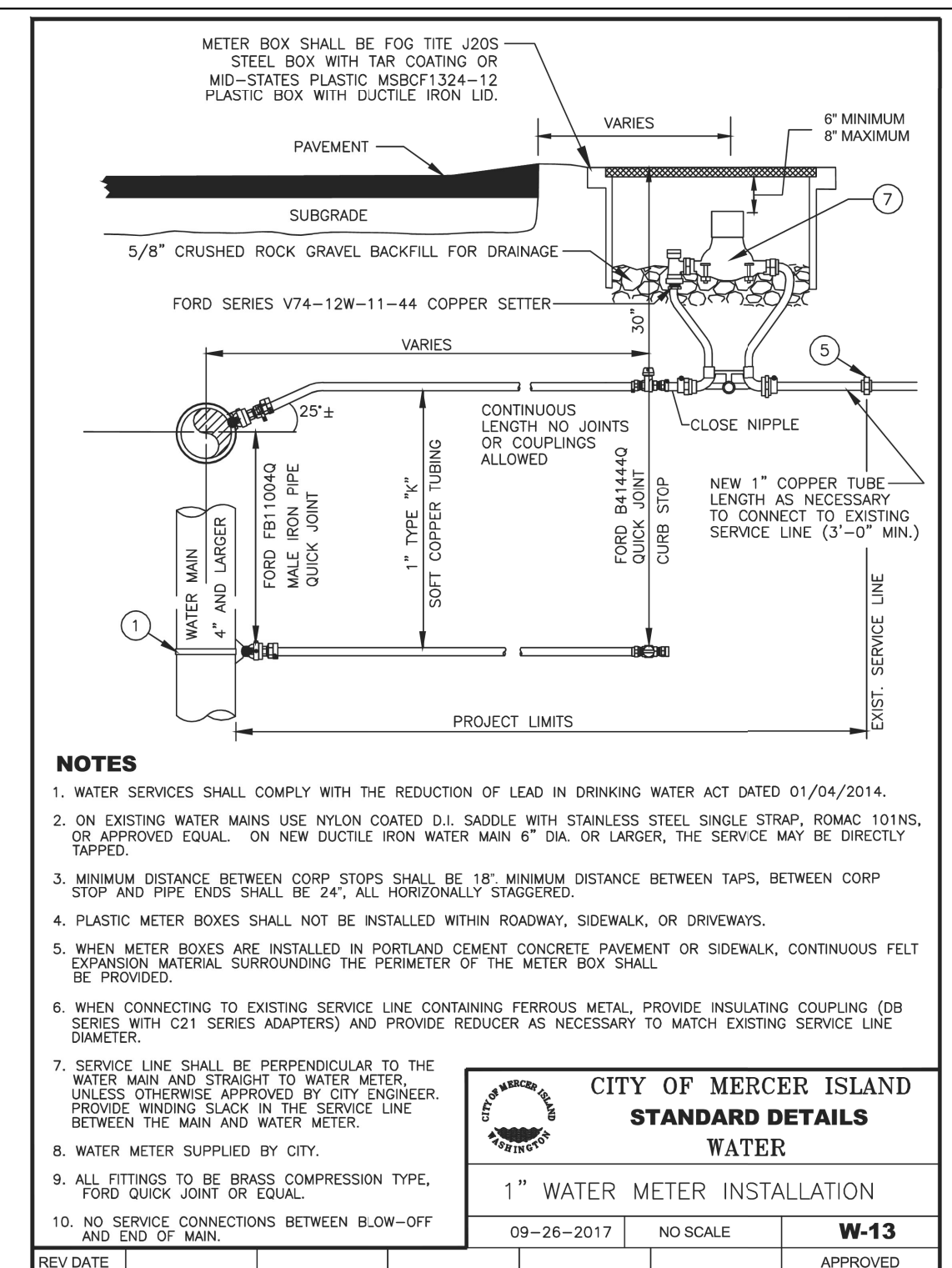

DATE	BY	CHKD BY	DATE	NOTES
11-30-2023	WJR	EDM		SUBMITTED TO CLIENT

1700 NW GILMAN BLVD, STE 200
ISSAQUAH, WA 98027
PHONE: (425) 821-5038

G2 CIVIL

APN: 413930-0045
STANDARD DETAILS
ADAMS SFR
MERCER ISLAND, WA
SAMUEL ADAMS
2612 1ST AVE SE
MERCER ISLAND, WA

SHEET
5 of 7

APPROVED: CITY OF MERCER ISLAND DEVELOPMENT SERVICES GROUP

JOB No.



DESIGN: TWW
DRAWN: KIB
CHECKED: RGC
APPROVED: RGC

REVISIONS:

JURISDICTIONAL APPROVAL STAMP:

PROJECT TITLE:
Adams Cargotechture
3508 96th ave SE
Mercer Island, WA 98040

ARCHITECT:
Adams Cargotechture
3508 96th ave SE
Mercer Island, WA 98040

ISSUE:

Permit

SHEET TITLE:

Ground Floor Plan

SCALE: 1/4" = 1'-0"

DATE: May 16, 2023

PROJECT NO: 13074-2022-01

SHEET NO:

S2.2

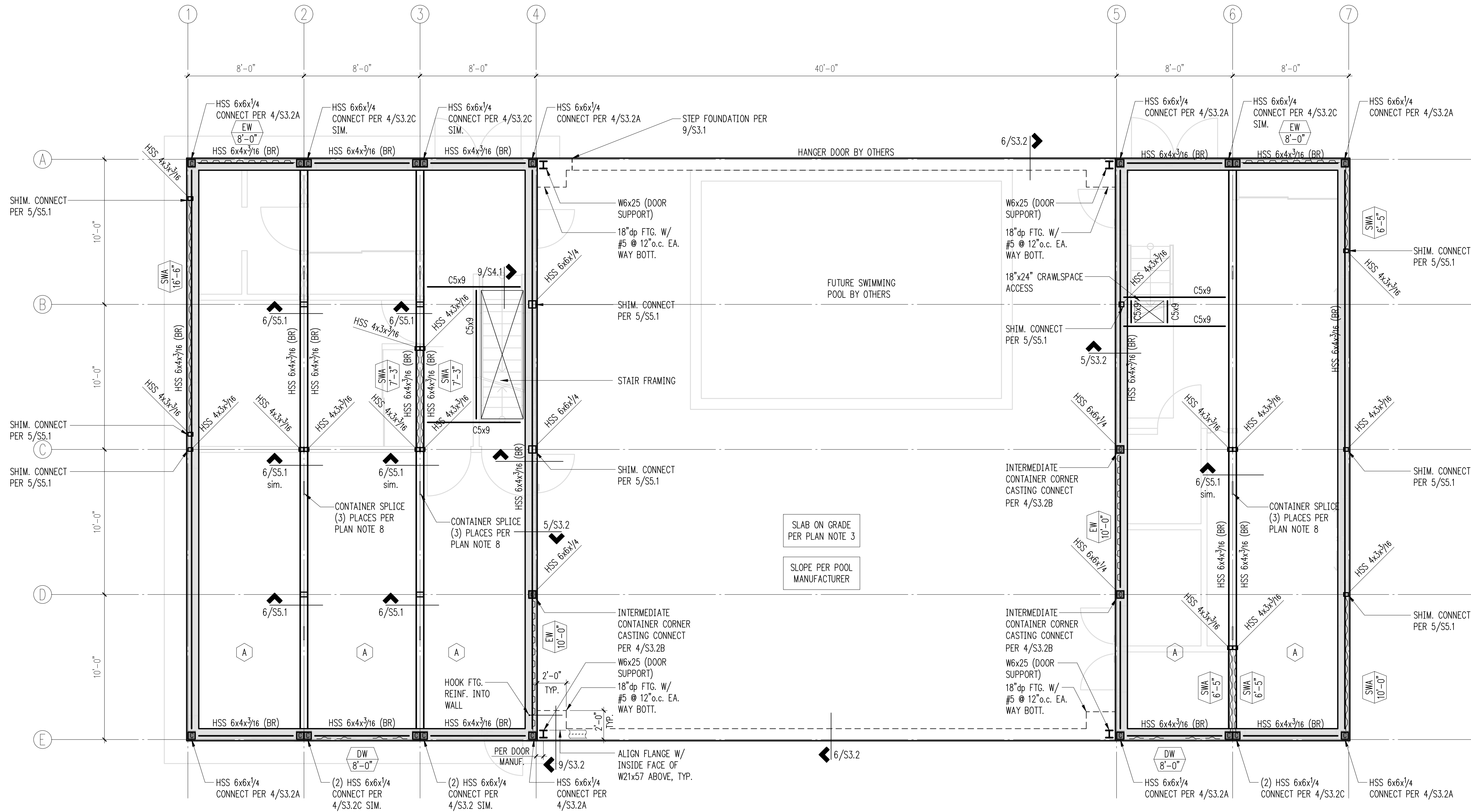

Plan Notes

- DO NOT SCALE DRAWINGS. REFER TO ARCHITECTURAL DRAWINGS FOR ALL DIMENSIONS.
- THE BOTTOM OF ALL EXTERIOR FOOTINGS SHALL BE 18" MINIMUM BELOW GRADE.
- 4" CONCRETE SLAB OVER 10 MIL VAPOR BARRIER ON 4" OF GRAVEL OR CRUSHED ROCK OVER FIRM UNDISTURBED SOIL OR ENGINEERED COMPACTED BACK-FILL. REINFORCE WITH #3 AT 16"OC EACH WAY. PROVIDE CONSTRUCTION/CONTROL JOINTS PER DETAIL 8/S3.1.
- PROVIDE CORNER BARS PER DETAIL 12/S3.1 AT ALL WALL AND FOOTING INTERSECTIONS.
- CONTAINER DOORS AND WINDOWS TO BE LOCATED BY CONTAINER MANUFACTURER AND HEADERS TO BE PROVIDED PER DETAIL 4/S5.2
- CONTAINER POSTS/COLUMNS TO BE LOCATED BY CONTAINER MANUFACTURER OR AS SHOWN ON PLANS TO BE ATTACHED PER DETAIL 2/S5.1
- C5 FRAMING TO BE FACTORY WELDED PER FLOOR JOIST REQUIREMENTS.
- PROVIDE CONTAINER TO CONTAINER SPLICES PER 4/S5.1 IN THREE PLACES EACH CONTAINER LINE. LOCATE SPLICES 1'-0" EITHER SIDE OF FROM QUARTER POINTS. OFFSET SPLICES TO CLOSEST AVAILABLE SPACE AT WALLS.
- REFER TO GENERAL STRUCTURAL NOTES FOR ADDITIONAL REQUIREMENTS.

Legend

- STEM WALL & FOOTING
- HEADER/BEAM PER PLAN
- TOP RAIL
- BOTTOM RAIL
- CORNER CASTING LOCATION ABOVE
- CONTAINER CORRUGATED STEEL SHEAR WALL
- SHEAR WALL PER 4/S5.2
- SHEAR WALL END PANEL PER 4/S5.2
- DOOR WALL END PANEL PER 11/S5.2
- CANTILEVERED COLUMN SHEAR WALL PER 4/S5.2

Ground Floor Plan
Scale: 1/4" = 1'-0"

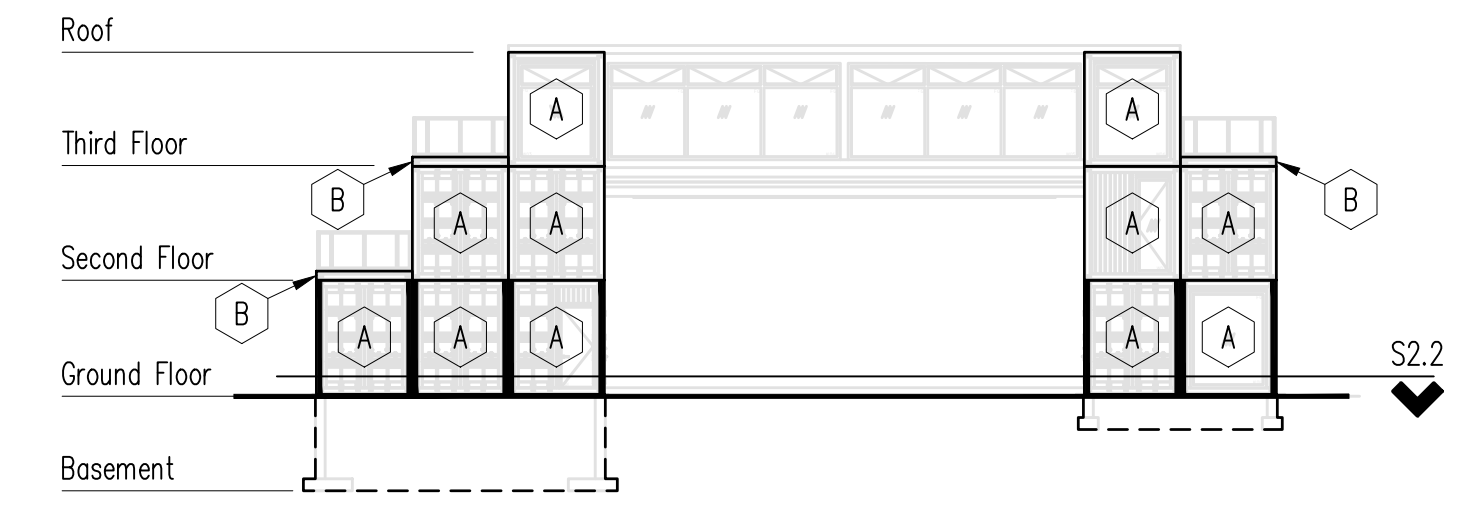

Container Schedule & Level Keyplan

- CONTAINER SHALL BE INTERMODAL, CFC CERTIFIED TYPE AAA, 40' HIGH CUBE.
- CONTAINER SHALL BE INTERMODAL, CFC CERTIFIED 40' PLATFORM TYPE.



DESIGN: TWW
 DRAWN: KIB
 CHECKED: RGC
 APPROVED: RGC

REVISIONS:

 JURISDICTIONAL APPROVAL STAMP:

PROJECT TITLE:
Adams Cargotechture
 3508 96th ave SE
 Mercer Island, WA 98040

ARCHITECT:
Adams Cargotechture
 3508 96th ave SE
 Mercer Island, WA 98040

ISSUE:
Permit
 SHEET TITLE:

Second Floor Plan
 SCALE: 1/4" = 1'-0"
 DATE: May 16, 2023
 PROJECT NO: 13074-2022-01
 SHEET NO:

S2.3

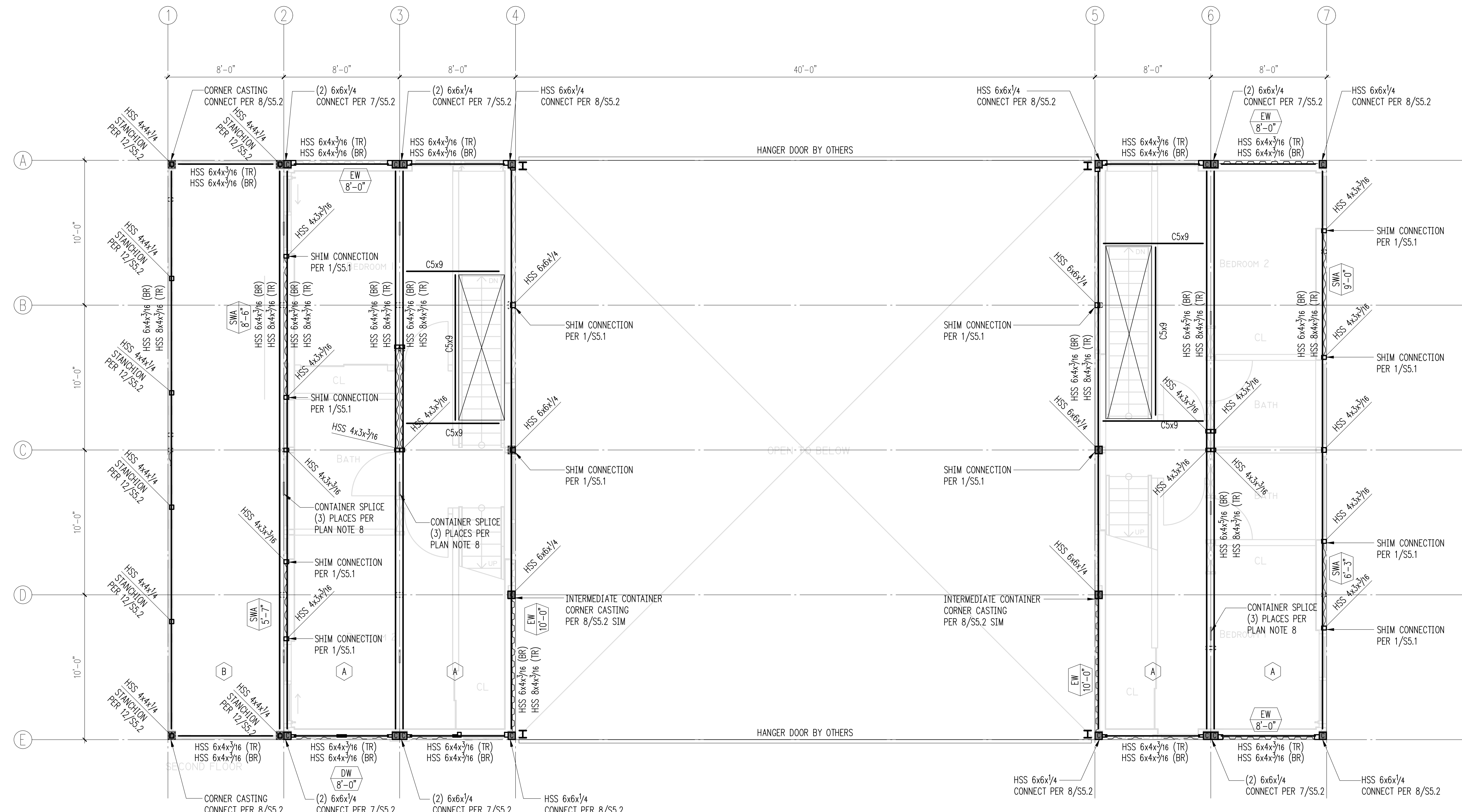

Plan Notes

- DO NOT SCALE DRAWINGS. REFER TO ARCHITECTURAL DRAWINGS FOR ALL DIMENSIONS.
- FLOOR SHEATHING SHALL BE 1 1/8" MIN. PER CONTAINER MANUFACTURER SPAN RATING 48/24. GLUE AT 12"OC.
- REFER TO 1/S5.2, 5/S5.2/ & 6/S5.2 FOR TYPICAL CONTAINER CONSTRUCTION DETAILS.
- CONTAINER DOORS AND WINDOWS TO BE LOCATED BY CONTAINER MANUFACTURER AND HEADERS TO BE PROVIDED PER DETAIL 4/S5.2.
- CONTAINER POSTS/COLUMNS TO BE LOCATED BY CONTAINER MANUFACTURER OR AS SHOWN ON PLANS TO BE ATTACHED PER DETAIL 2/S5.1.
- CONTAINER POSTS/COLUMNS TO BE LOCATED BY CONTAINER MANUFACTURER OR AS SHOWN ON PLANS TO BE ATTACHED PER DETAIL 2/S5.1.
- C5 FRAMING TO BE FACTORY WELDED PER FLOOR JOIST REQUIREMENTS.
- PROVIDE CONTAINER TO CONTAINER SPLICES PER 4/S5.1 IN THREE PLACES EACH CONTAINER LINE. LOCATE SPLICES 1'-0" EITHER SIDE OF FROM QUARTER POINTS. OFFSET SPLICES TO CLOSEST AVAILABLE SPACE AT WALLS.
- REFER TO GENERAL STRUCTURAL NOTES FOR ADDITIONAL REQUIREMENTS.

Legend

- | | | | |
|-------|---------------------------------------|--------------|---|
| (TR) | HEADER/BEAM PER PLAN | SWx
X'-X" | SHEAR WALL PER 4/S5.2 |
| (BR) | TOP RAIL | EW
X'-X" | SHEAR WALL END PANEL PER 4/S5.2 |
| (BR) | BOTTOM RAIL | DW
X'-X" | DOOR WALL END PANEL PER 11/S5.2 |
| ■ | CORNER CASTING LOCATION ABOVE | CW
X'-X" | CANTILEVERED COLUMN SHEAR WALL PER 4/S5.2 |
| ~~~~~ | CONTAINER CORRUGATED STEEL SHEAR WALL | | |

Second Floor Plan

Scale: 1/4" = 1'-0"

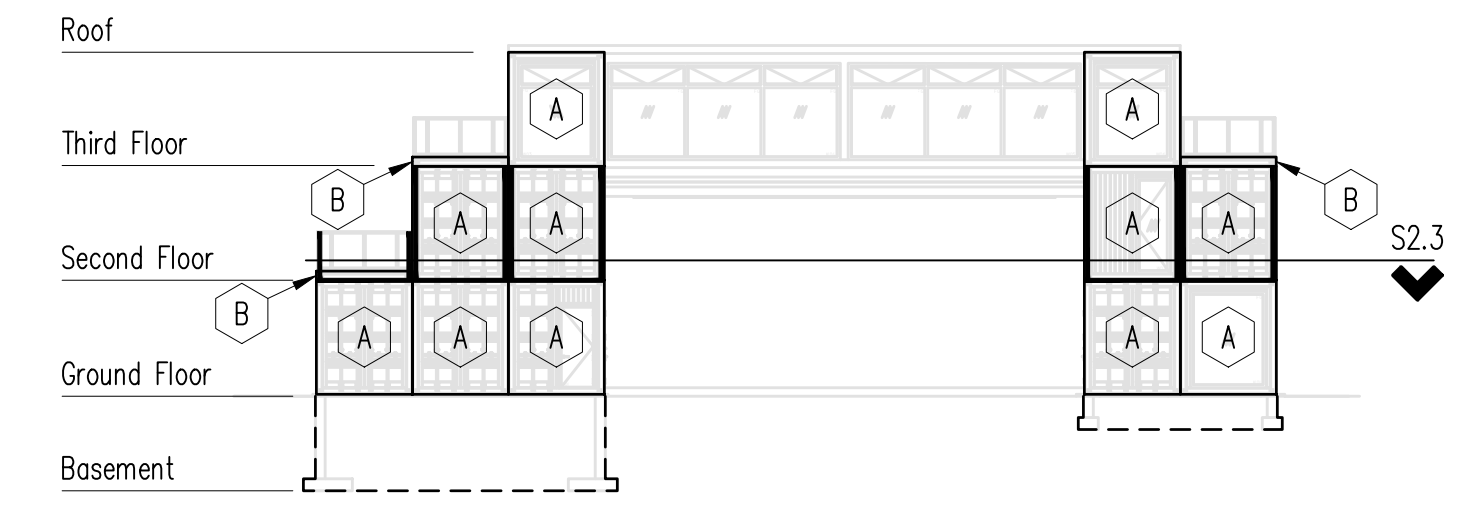

Container Schedule & Level Keyplan

- A CONTAINER SHALL BE INTERMODAL, CFC CERTIFIED TYPE AAA, 40' HIGH CUBE.
- B CONTAINER SHALL BE INTERMODAL, CFC CERTIFIED 40' PLATFORM TYPE.



DESIGN: TWW
 DRAWN: KIB
 CHECKED: RGC
 APPROVED: RGC

REVISIONS:

JURISDICTIONAL APPROVAL STAMP:

PROJECT TITLE:

Adams Cargotechture
 3508 96th ave SE
 Mercer Island, WA 98040

ARCHITECT:

Adams Cargotechture
 3508 96th ave SE
 Mercer Island, WA 98040

ISSUE:

Permit

SHEET TITLE:

Third Floor Plan

SCALE: 1/4" = 1'-0"

DATE: May 16, 2023

PROJECT NO: 13074-2022-01

SHEET NO:

S2.4

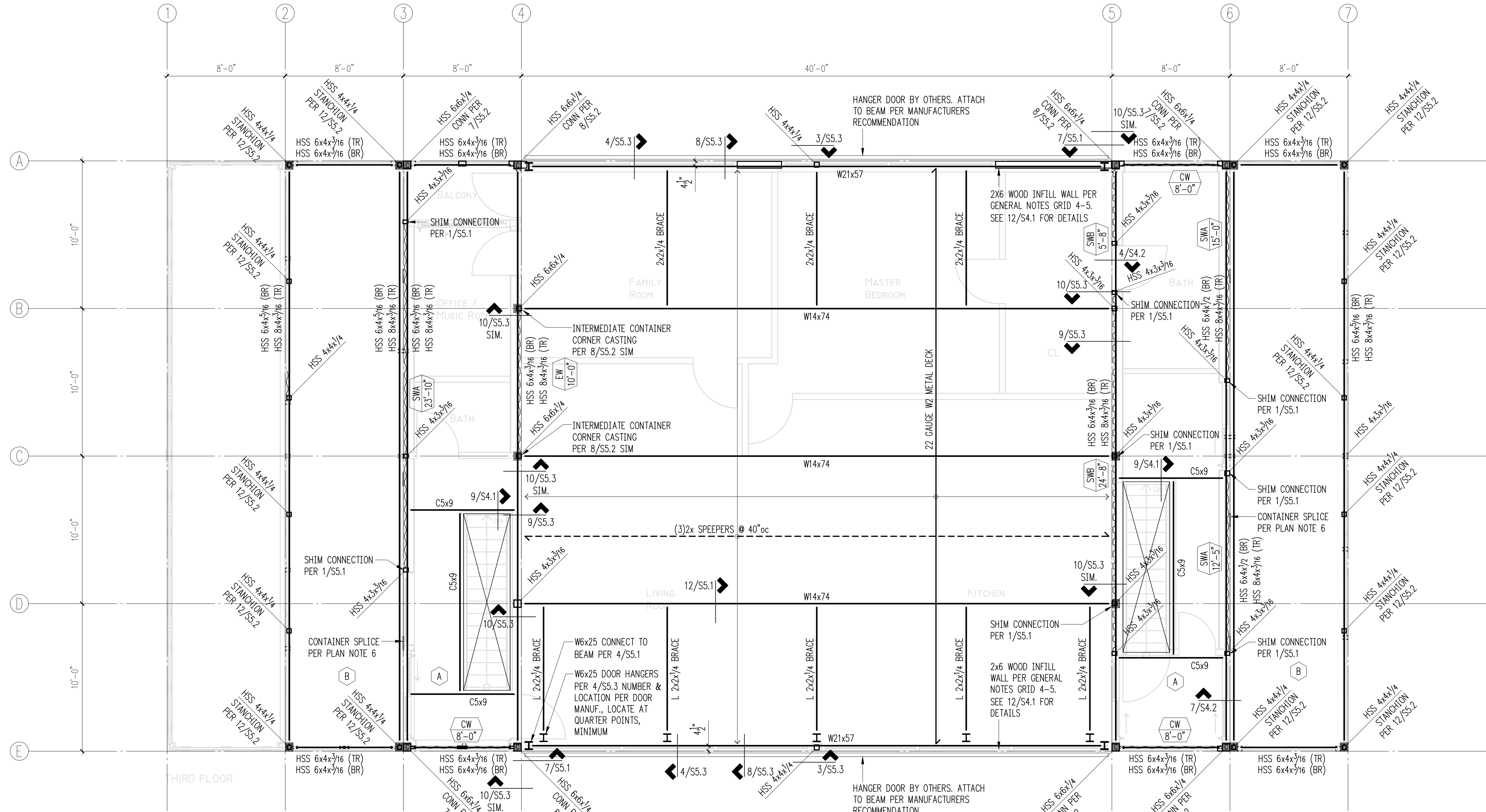

Plan Notes

- DO NOT SCALE DRAWINGS. REFER TO ARCHITECTURAL DRAWINGS FOR ALL DIMENSIONS. FACE GRAIN PERPENDICULAR TO SUPPORTS OVER ROOF FRAMING PER PLAN.
- FLOOR OVERFRAMING SHALL BE 1-1/8" A.P.A. RATED PANELS (EXPOSURE 1, SPAN RATING 32/16), FACE GRAIN PERPENDICULAR TO SUPPORTS OVER SLEEPERS PER PLAN. NAIL SHEATHING AT ALL FRAMED PANEL EDGES WITH 10D AT 6" O.C. AND TO ALL INTERMEDIATE FRAMING AT 12" O.C. FLOOR FRAMING SHALL BE 22G ASC DG W2 METAL DECK PER 10/S5.2.
- REFER TO 1/S5.2, 5/S5.2/ & 6/S5.2 FOR TYPICAL CONTAINER CONSTRUCTION DETAILS.
- CONTAINER DOORS AND WINDOWS TO BE LOCATED BY CONTAINER MANUFACTURER AND HEADERS TO BE PROVIDED PER DETAIL 4/S5.2.
- CONTAINER POSTS/COLUMNS TO BE LOCATED BY CONTAINER MANUFACTURER OR AS SHOWN ON PLANS TO BE ATTACHED PER DETAIL 2/S5.1.
- C5 FRAMING TO BE FACTORY WELDED PER FLOOR JOIST REQUIREMENTS.
- PROVIDE CONTAINER TO CONTAINER SPLICES PER 4/S5.1 IN THREE PLACES EACH CONTAINER LINE. LOCATE SPLICES 1'-0" EITHER SIDE OF FROM QUARTER POINTS. OFFSET SPLICES TO CLOSEST AVAILABLE SPACE AT WALLS.
- REFER TO GENERAL STRUCTURAL NOTES FOR ADDITIONAL REQUIREMENTS.

Legend

- | | | | |
|------|---------------------------------------|--|---|
| — | HEADER/BEAM PER PLAN | | SHEAR WALL PER 4/S5.2 |
| (TR) | TOP RAIL | | SHEAR WALL END PANEL PER 4/S5.2 |
| (BR) | BOTTOM RAIL | | DOOR WALL END PANEL PER 11/S5.2 |
| | CORNER CASTING LOCATION ABOVE | | CANTILEVERED COLUMN SHEAR WALL PER 4/S5.2 |
| | CONTAINER CORRUGATED STEEL SHEAR WALL | | |

Third Floor Plan

Scale: 1/4" = 1'-0"

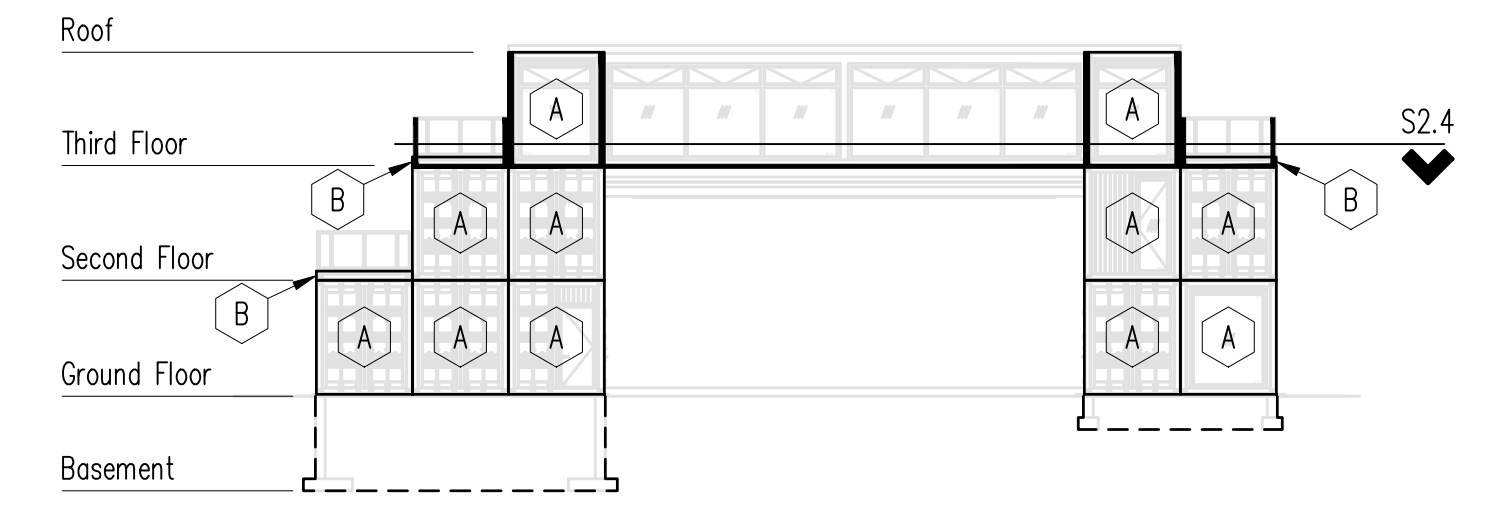

Container Schedule & Level Keyplan

- A CONTAINER SHALL BE INTERMODAL, CFC CERTIFIED TYPE AAA, 40' HIGH CUBE.
- B CONTAINER SHALL BE INTERMODAL, CFC CERTIFIED 40' PLATFORM TYPE.



DESIGN:	TWW
DRAWN:	KIB
CHECKED:	RGC
APPROVED:	RGC

REVISIONS:	
JURISDICTIONAL APPROVAL STAMP:	

PROJECT TITLE:
Adams Cargotechture
 3508 96th ave SE
 Mercer Island, WA 98040

ARCHITECT:
Adams Cargotechture
 3508 96th ave SE
 Mercer Island, WA 98040

ISSUE:
Permit
 SHEET TITLE:

SCALE: 1/4" = 1'-0"
 DATE: May 16, 2023
 PROJECT NO: 13074-2022-01
 SHEET NO:

S2.5

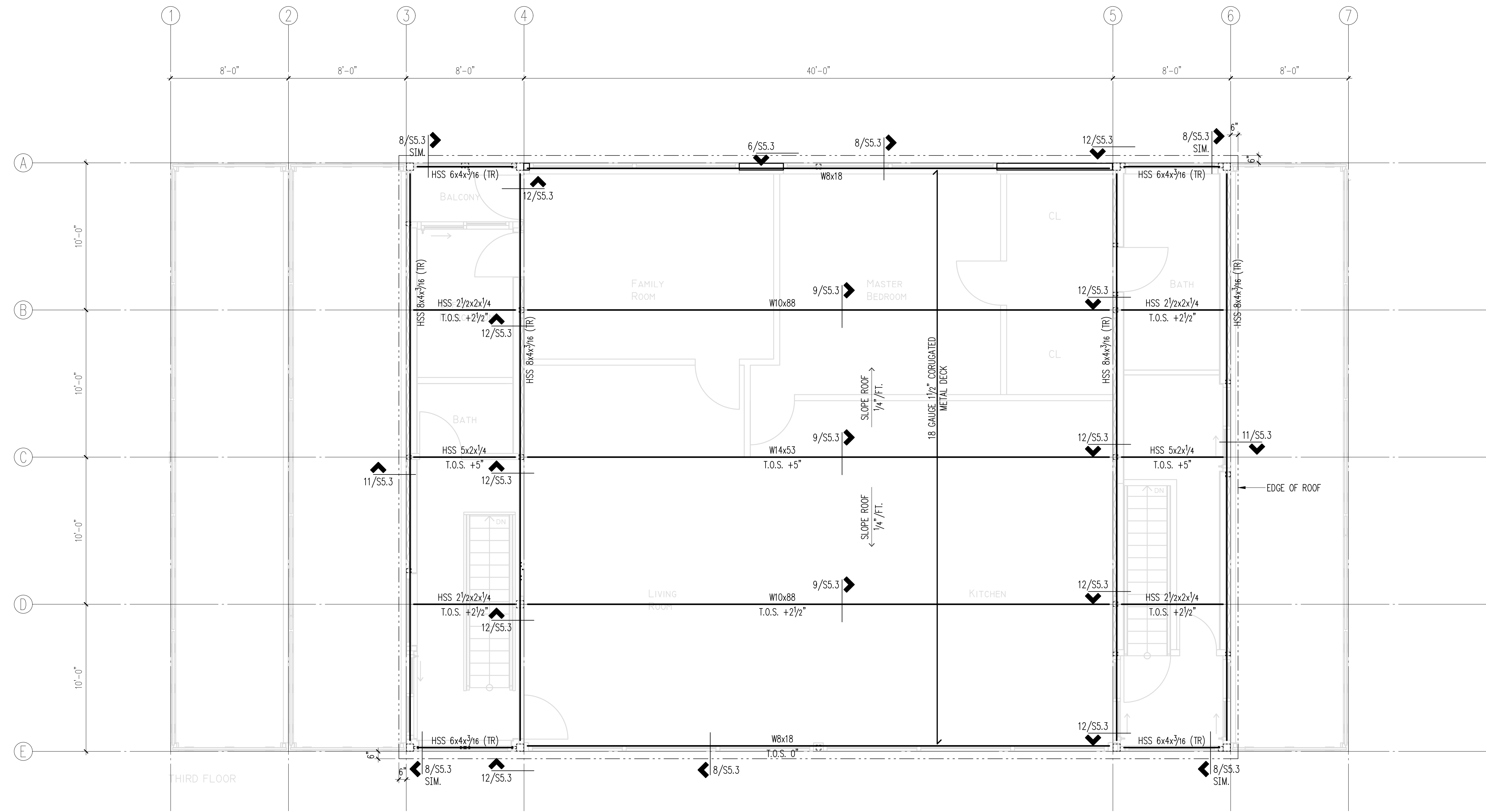

Plan Notes

- DO NOT SCALE DRAWINGS. REFER TO ARCHITECTURAL DRAWINGS FOR ALL DIMENSIONS. FACE GRAIN PERPENDICULAR TO SUPPORTS OVER ROOF FRAMING PER PLAN.
- ROOF FRAMING SHALL BE 18G ASC DG B36 METAL DECK PER 2/S5.3.
- REFER TO 1/S5.2, 5/S5.2/ & 6/S5.2 FOR TYPICAL CONTAINER CONSTRUCTION DETAILS.
- CONTAINER DOORS AND WINDOWS TO BE LOCATED BY CONTAINER MANUFACTURER AND HEADERS TO BE PROVIDED PER DETAIL 4/S5.2.
- CONTAINER POSTS/COLUMNS TO BE LOCATED BY CONTAINER MANUFACTURER OR AS SHOWN ON PLANS TO BE ATTACHED PER DETAIL 2/S5.1.
- C5 FRAMING TO BE FACTORY WELDED PER FLOOR JOIST REQUIREMENTS.
- PROVIDE CONTAINER TO CONTAINER SPLICES PER 4/S5.1 IN THREE PLACES EACH CONTAINER LINE. LOCATE SPLICES 1'-0" EITHER SIDE OF FROM QUARTER POINTS. OFFSET SPLICES TO CLOSEST AVAILABLE SPACE AT WALLS.
- REFER TO GENERAL STRUCTURAL NOTES FOR ADDITIONAL REQUIREMENTS.

Legend

(TR)	HEADER/BEAM PER PLAN	(SWx X'-X')	SHEAR WALL PER 4/S5.2
(BR)	TOP RAIL	(EW X'-X')	SHEAR WALL END PANEL PER 4/S5.2
(C)	BOTTOM RAIL	(DW X'-X')	DOOR WALL END PANEL PER 11/S5.2
(C)	CORNER CASTING LOCATION ABOVE	(CW X'-X')	CANTILEVERED COLUMN SHEAR WALL PER 4/S5.2
(C)	CONTAINER CORRUGATED STEEL SHEAR WALL		
T.O.S.	TOP OF STEEL, ELEVATION RELATIVE TO TOP OF CORNER CASTING		

Roof Plan

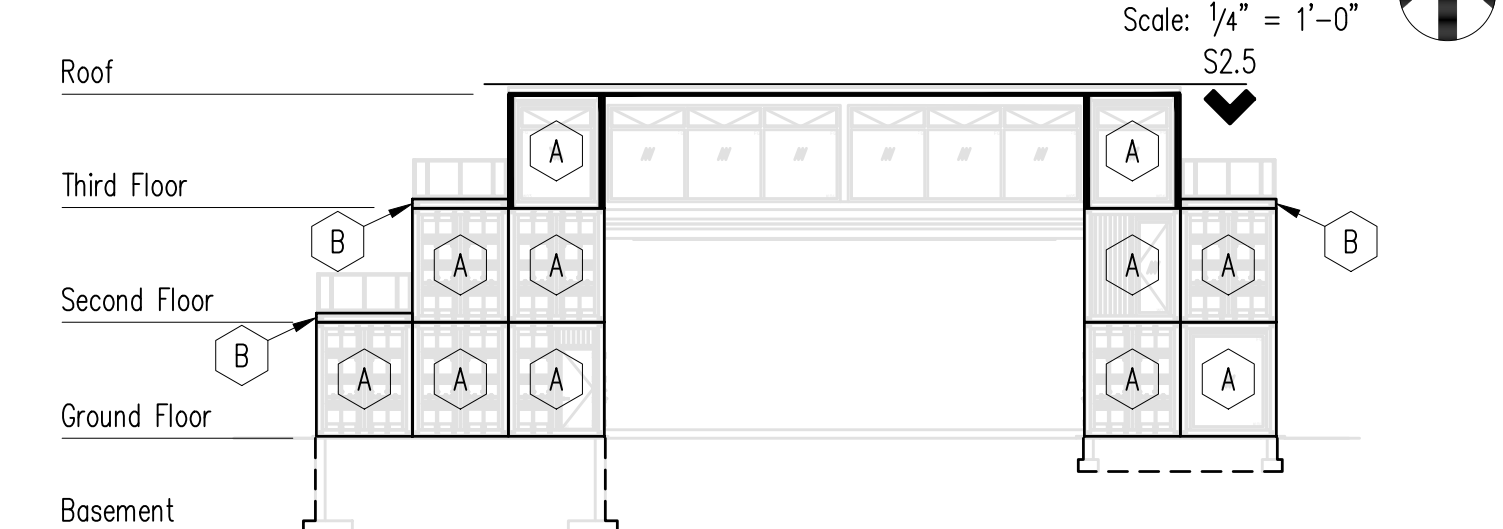

Container Schedule & Level Keyplan

- (A) CONTAINER SHALL BE INTERMODAL, CFC CERTIFIED TYPE AAA, 40' HIGH CUBE.
- (B) CONTAINER SHALL BE INTERMODAL, CFC CERTIFIED 40' PLATFORM TYPE.

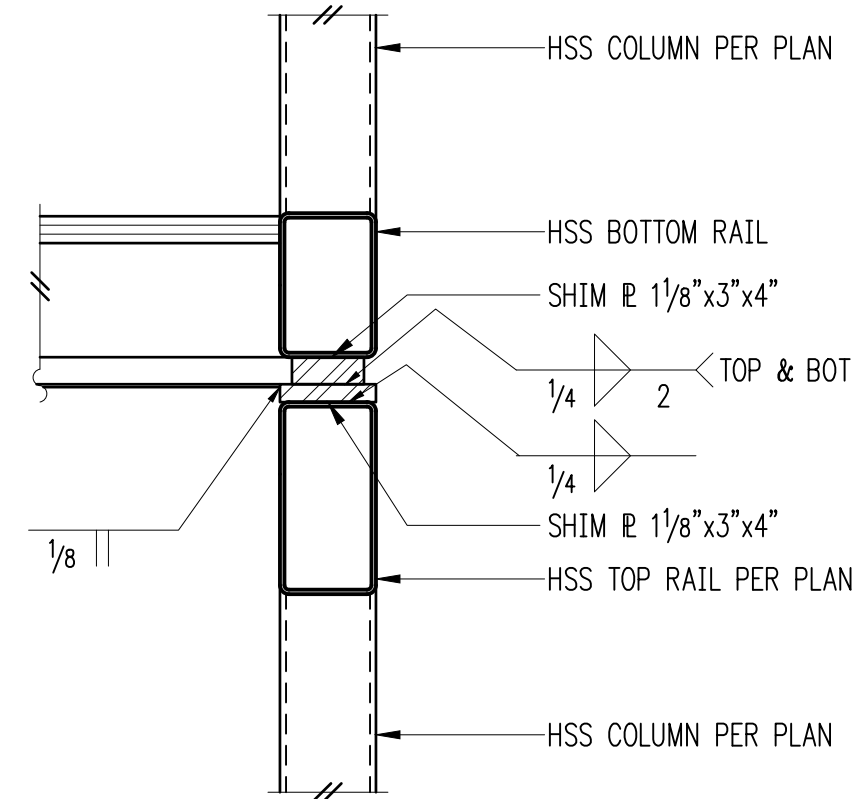

1/2" = 1'-0"
Container Shims 1

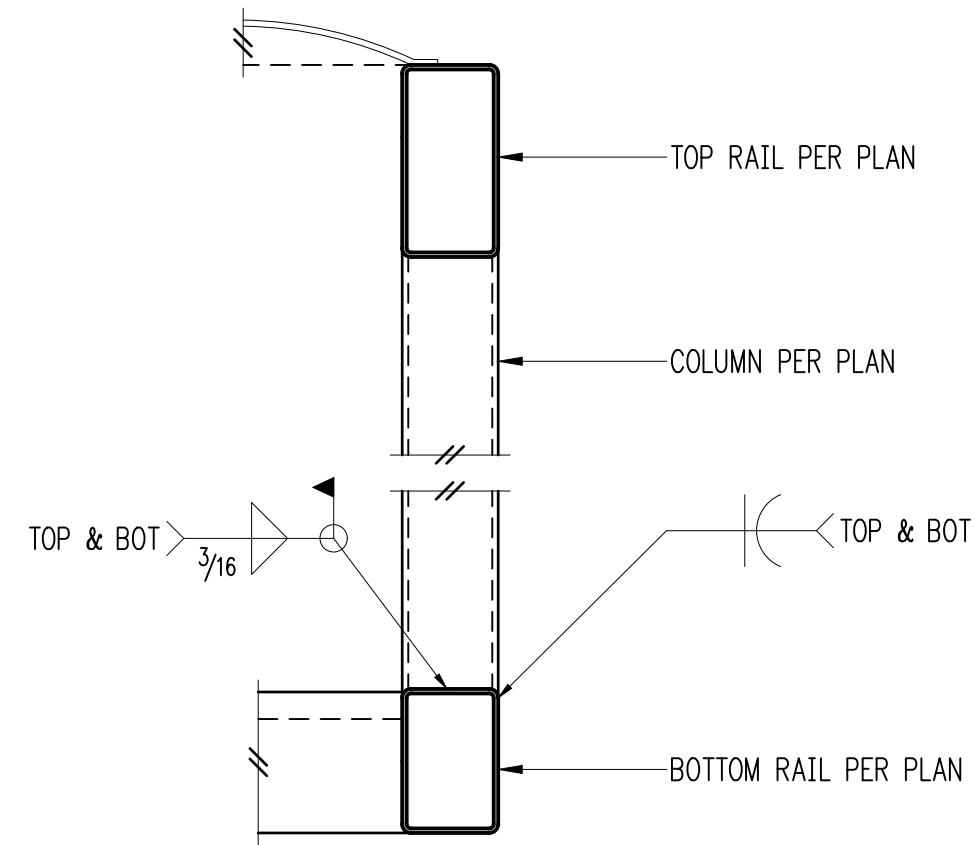

1/2" = 1'-0"
HSS Column 2

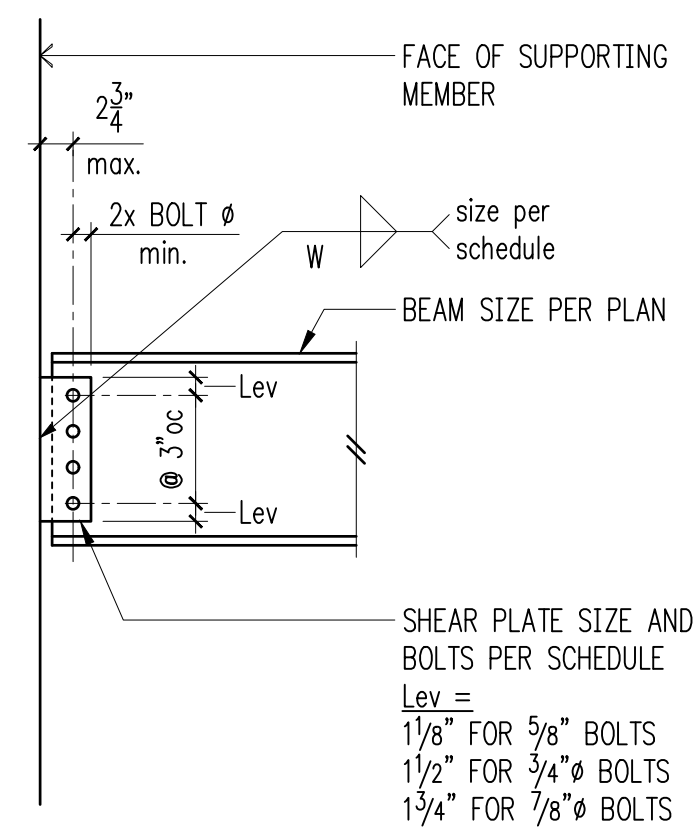

Shear Plate Schedule

Beam Size	No. of Bolts	Bolt Size	Plate Thickness	Weld Size
C5	2	5/8" ϕ @ 2" SPACING	1/4"	3/16"
W10	2	5/8" ϕ	1/4"	3/16"
W12, W14	3	3/4" ϕ	1/4"	3/16"

- NOTES:
- STANDARD OR SLOTTED HOLES MAY BE USED.
 - BOLT TYPE A325N.
 - Ⓜ MATERIAL - A36
 - SEE EXTENDED Ⓜ DETAIL FOR COLUMN WEB CONNECTIONS.

Typical Single Shear Plate Connection and Schedule 4

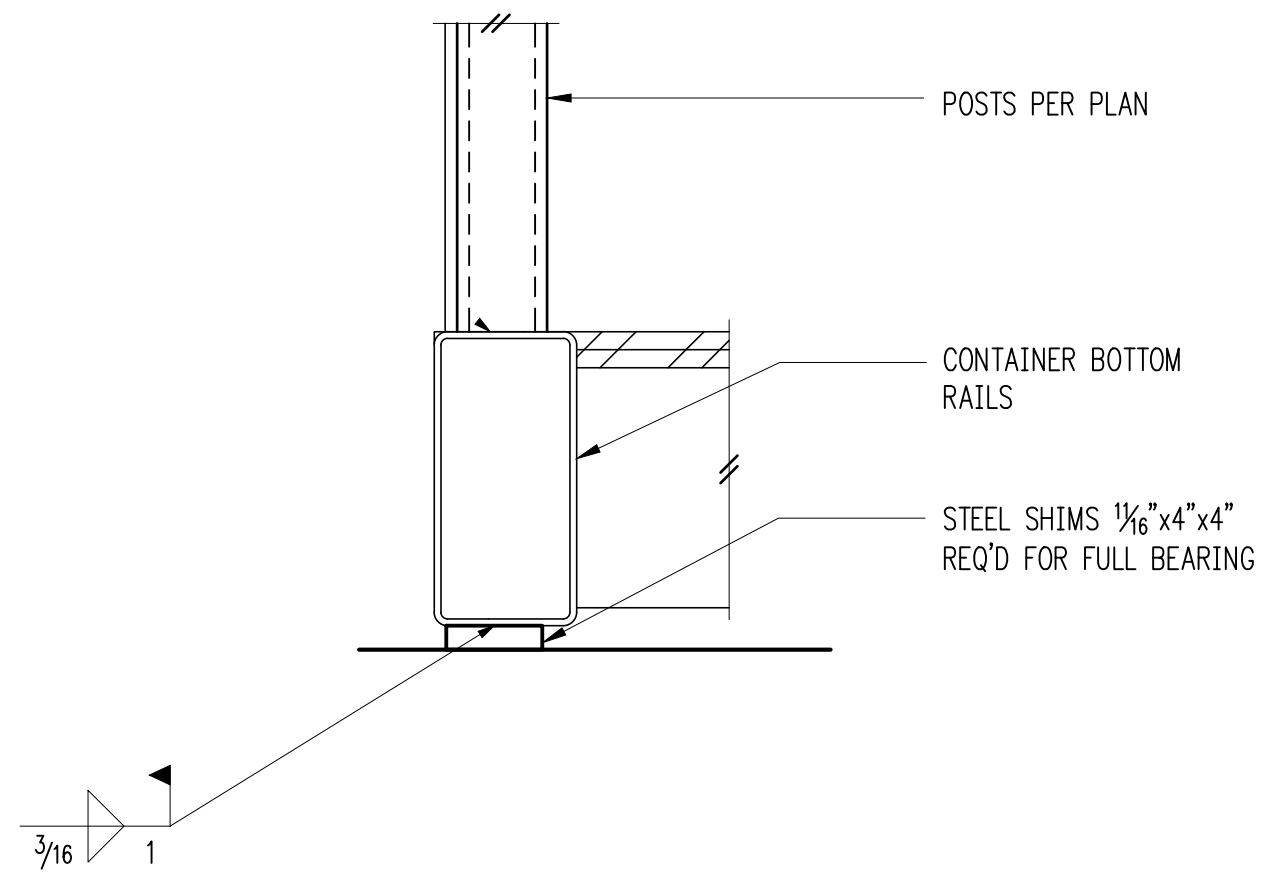

3" = 1'-0"
Container Shim @ Foundation 5

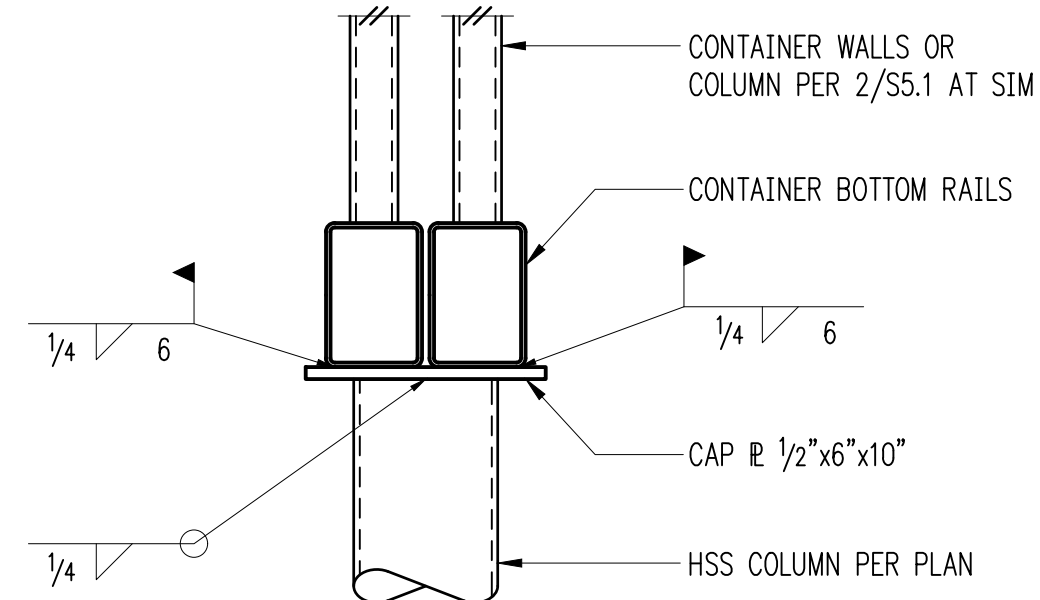

1/2" = 1'-0"
HSS Column Cap 6

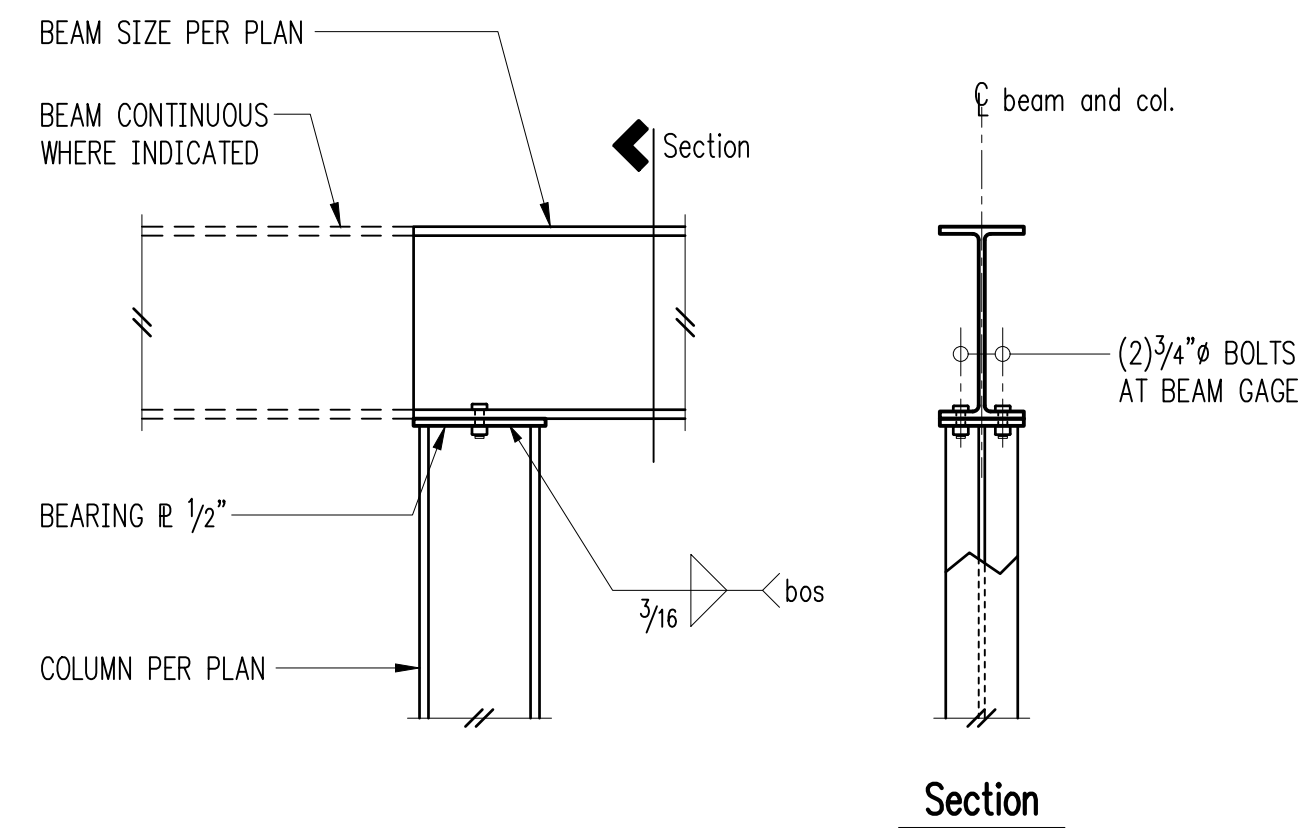

Garage Door Header 7

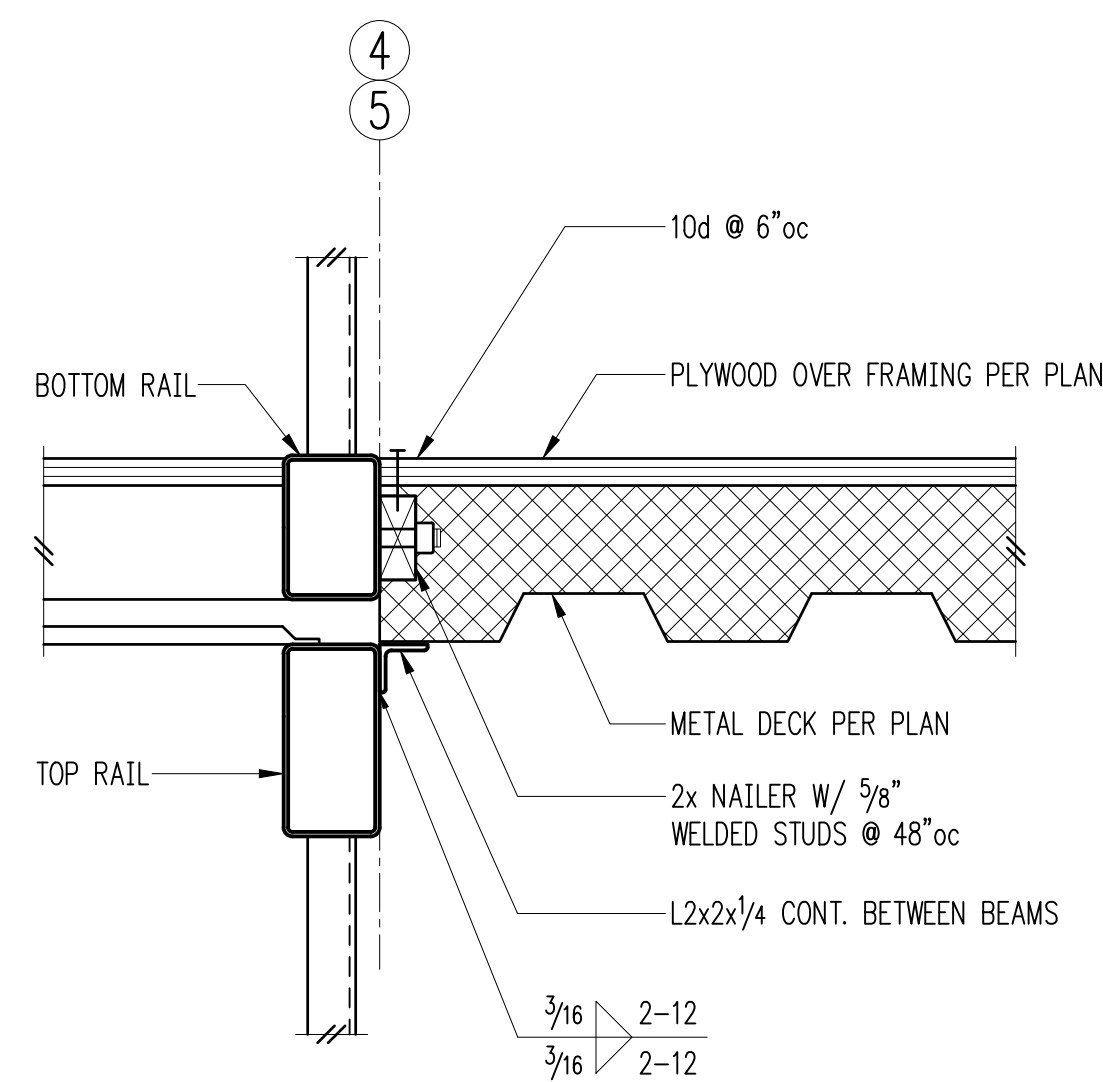

1/2" = 1'-0"
Floor Deck Support 9

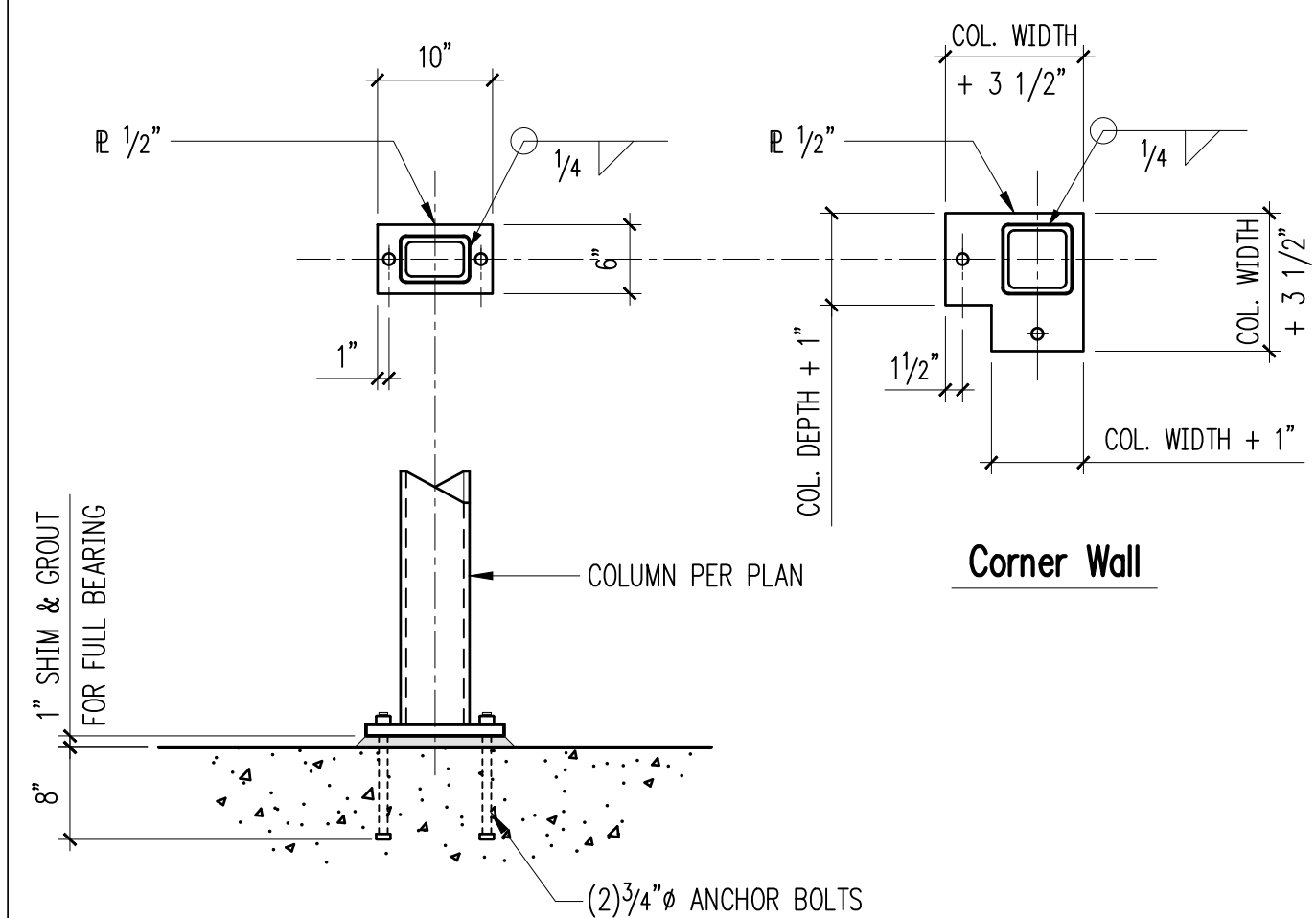

10

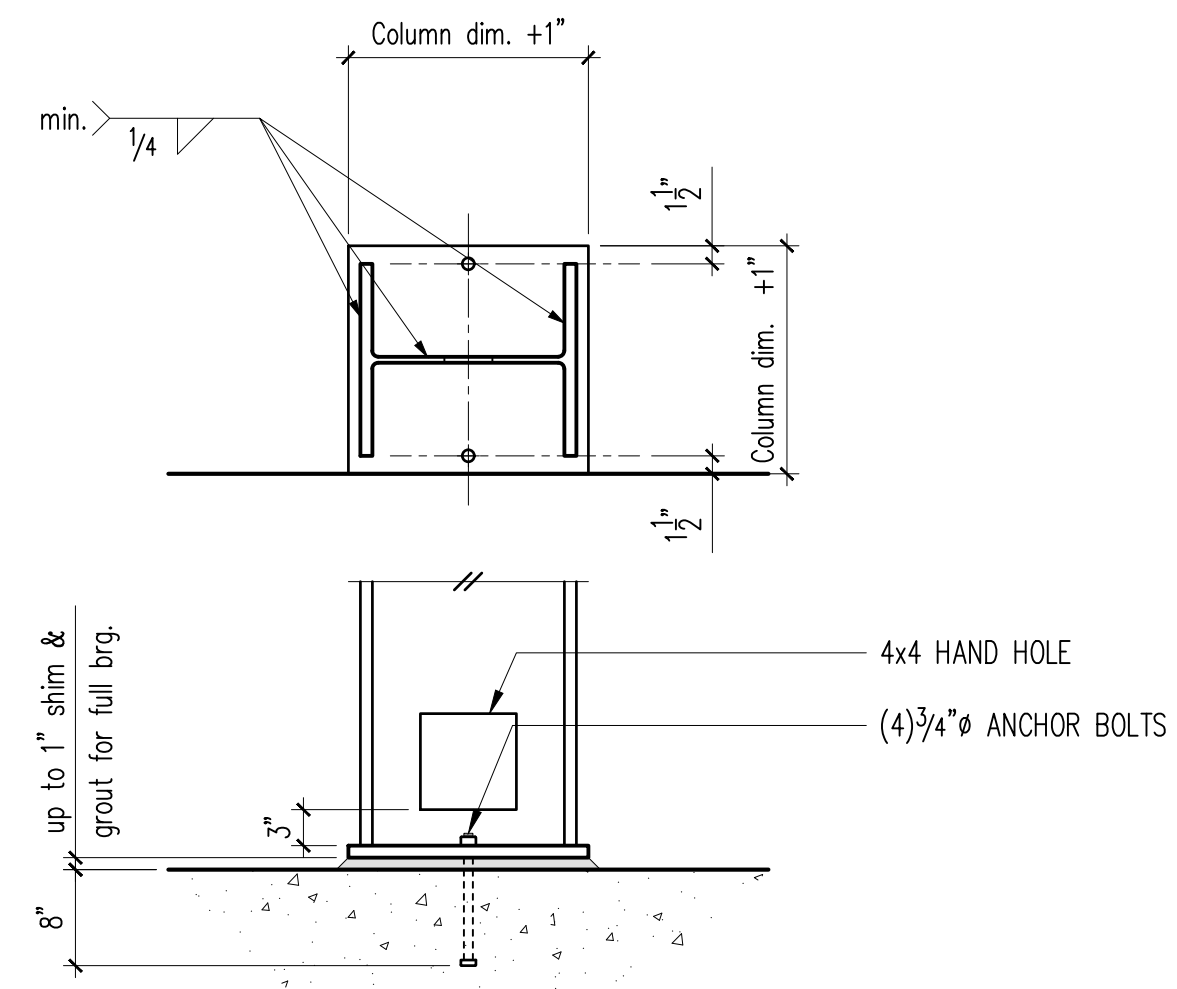

Baseplate - WF Columns (4)Bolts (Non-Lateral System) 11



DESIGN: TWW

DRAWN: KIB

CHECKED: RGC

APPROVED: RGC

REVISIONS:

JURISDICTIONAL APPROVAL STAMP:

PROJECT TITLE:
Adams Cargotechture
3508 96th ave SE
Mercer Island, WA 98040

ARCHITECT:
Adams Cargotechture
3508 96th ave SE
Mercer Island, WA 98040

ISSUE:
Permit

SHEET TITLE:

Column Details

SCALE: 3/4" = 1'-0" U.N.O.

DATE: May 16, 2023

PROJECT NO: 13074-2022-01

SHEET NO:



DESIGN: TWW
 DRAWN: KIB
 CHECKED: RGC
 APPROVED: RGC

REVISIONS:

JURISDICTIONAL APPROVAL STAMP:

PROJECT TITLE:
Adams Cargotechture
 3508 96th ave SE
 Mercer Island, WA 98040

ARCHITECT:
Adams Cargotechture
 3508 96th ave SE
 Mercer Island, WA 98040

ISSUE:
Permit

SHEET TITLE:
Container Details

SCALE: 1" = 1'-0" U.N.O.
 DATE: May 16, 2023
 PROJECT NO: 13074-2022-01
 SHEET NO:

S5.2

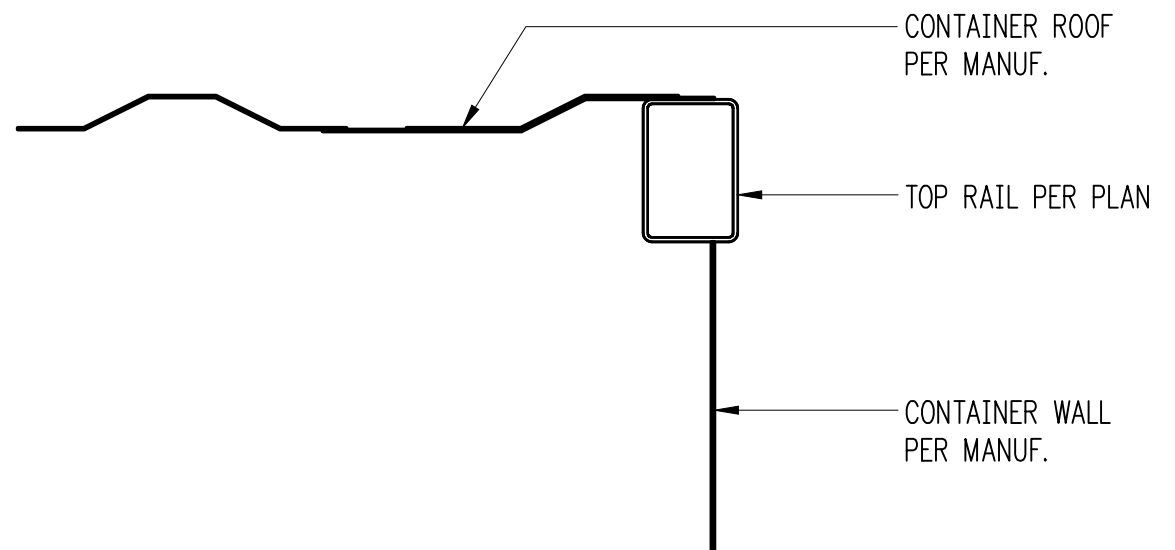

1/2" = 1'-0"
Container Roof Conn. 1

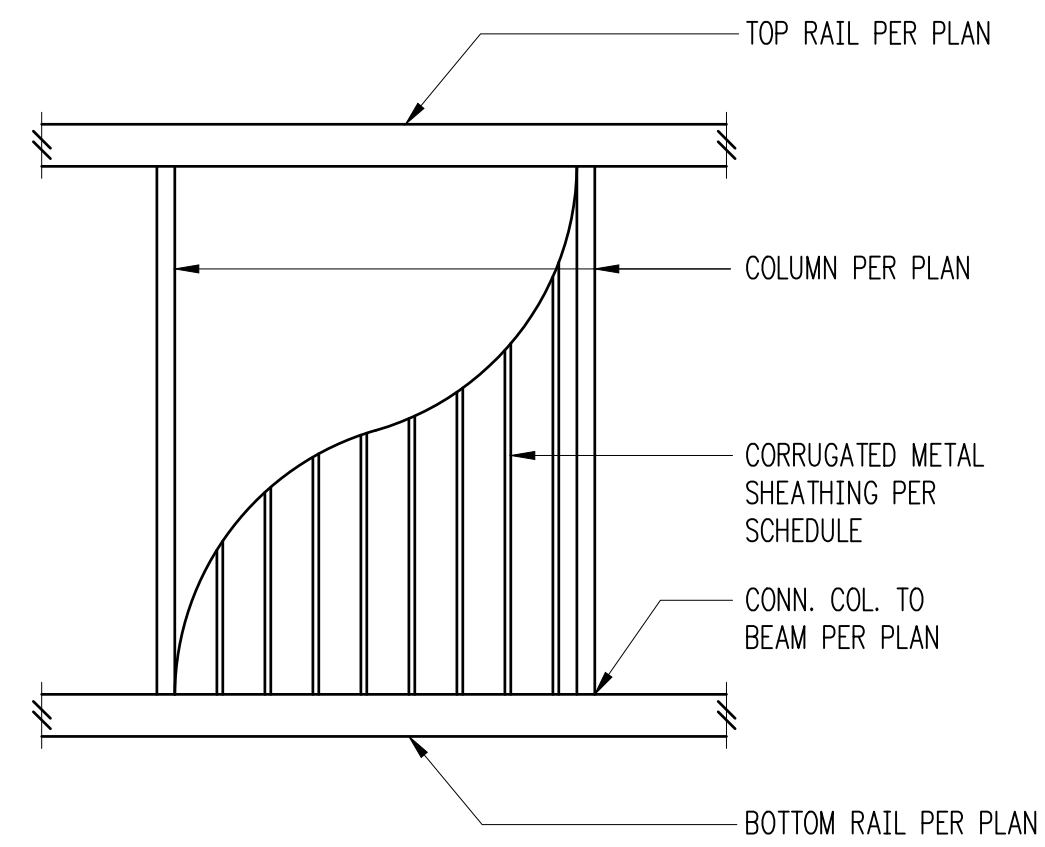

SWA/SWB

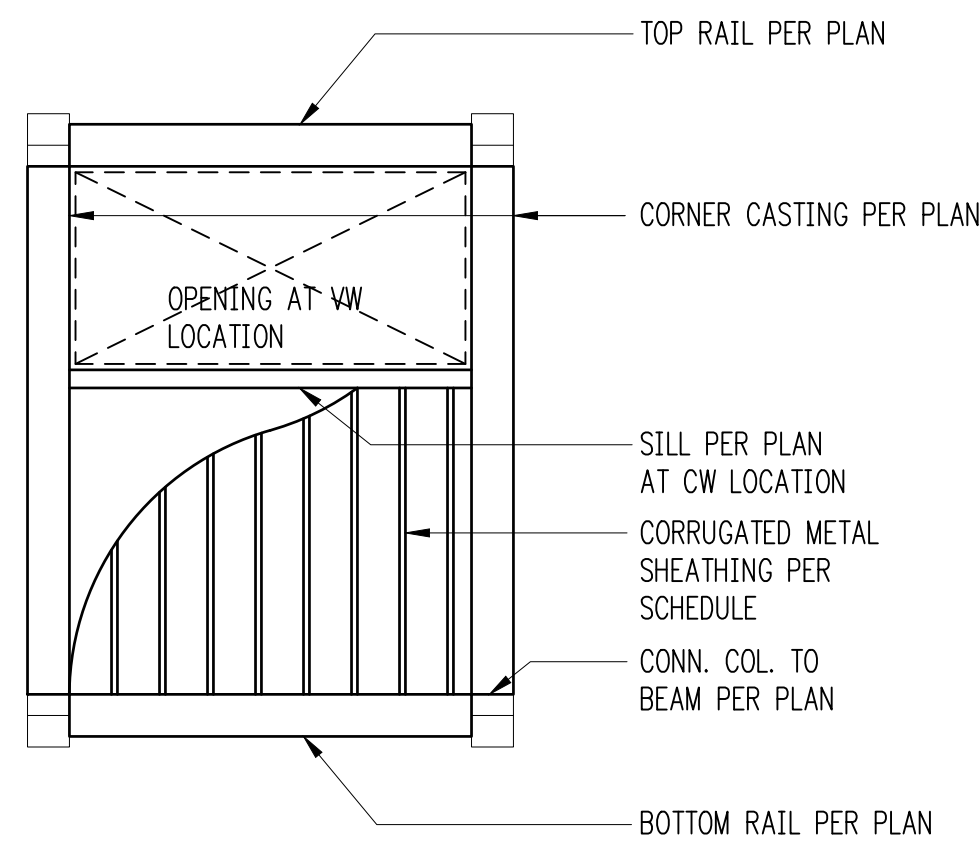

CW

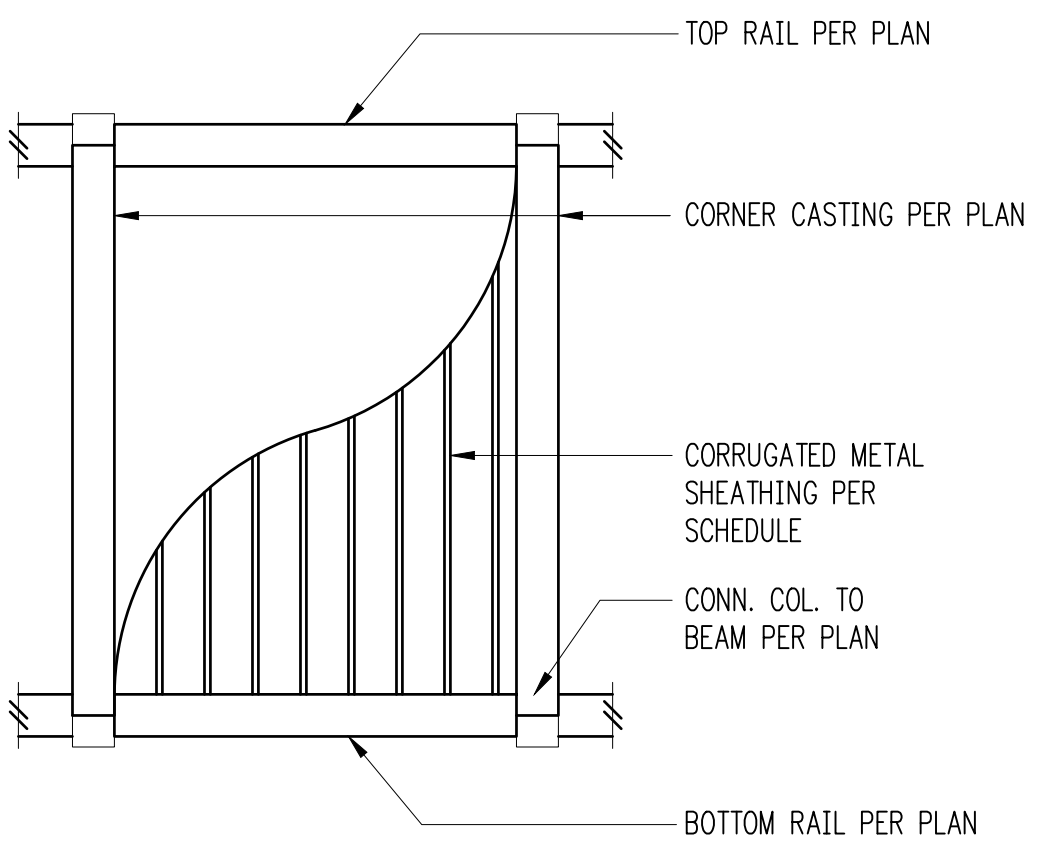

EW

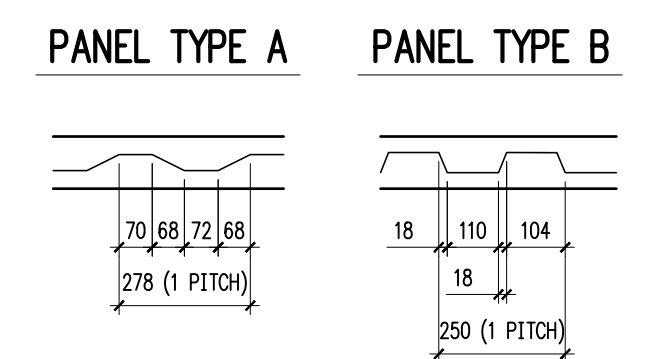

Shearwall Schedule

MARK	PANEL TYPE
SWA	A
EW	B
CW	A
SWB	B

3/4" = 1'-0"

4

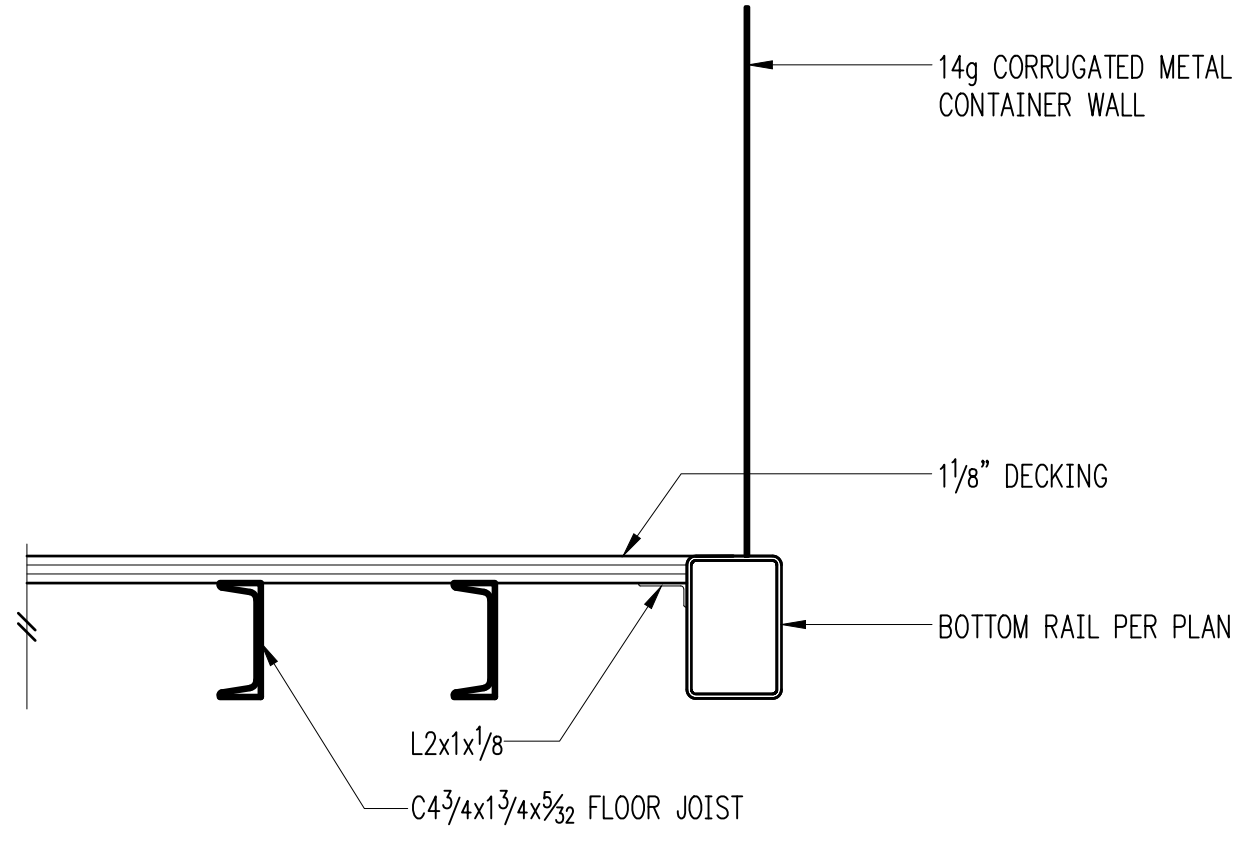

1/2" = 1'-0"
Container Floor Conn. 5

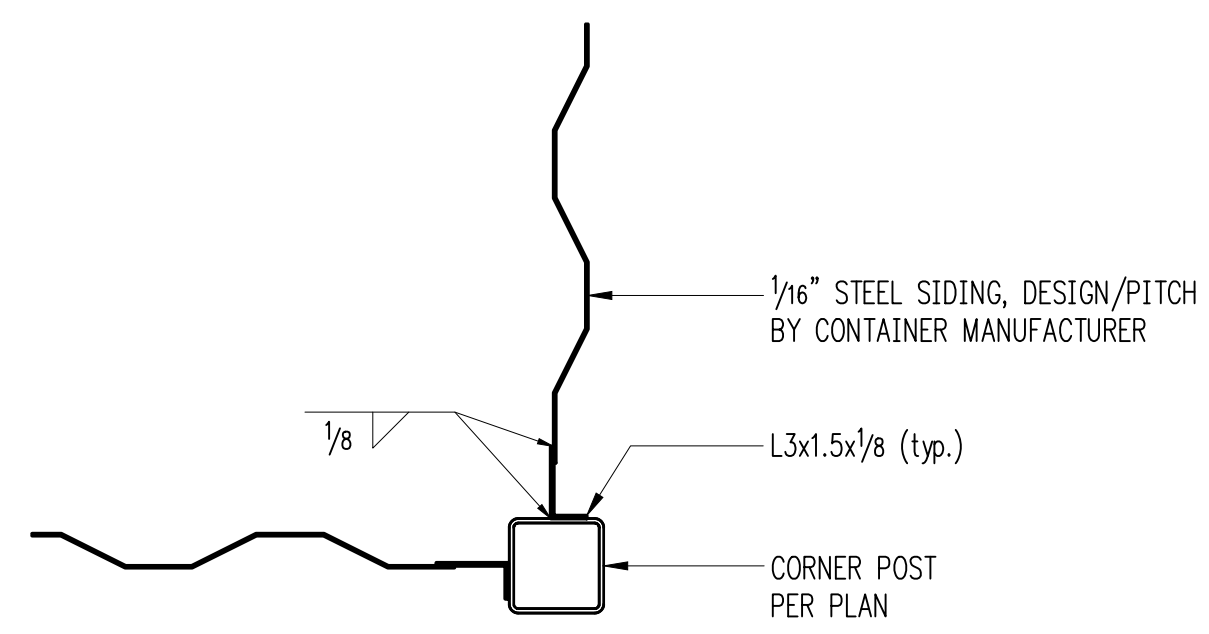

1/2" = 1'-0"
Corner Casting Conn. 6

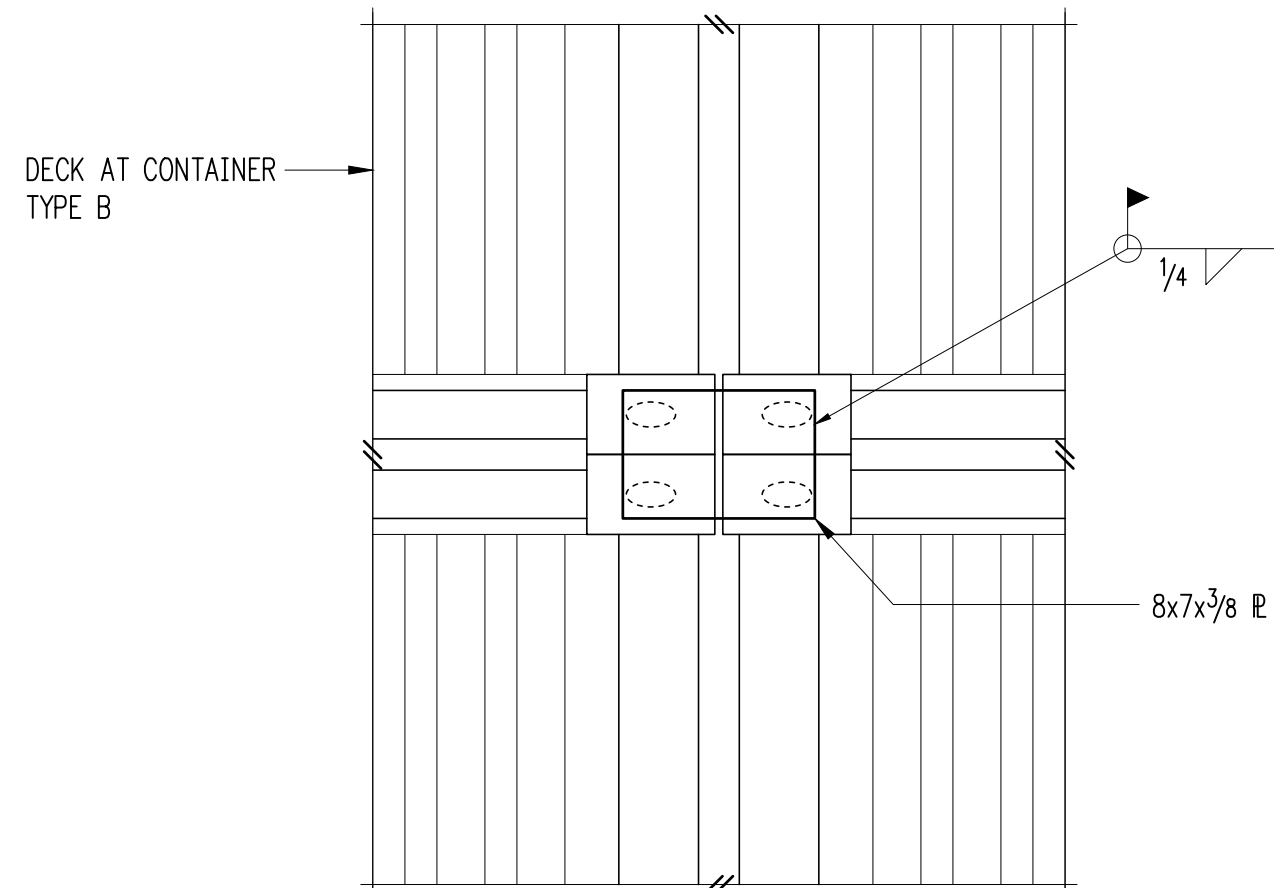

1" = 1'-0"
Container - Container End Connections 7

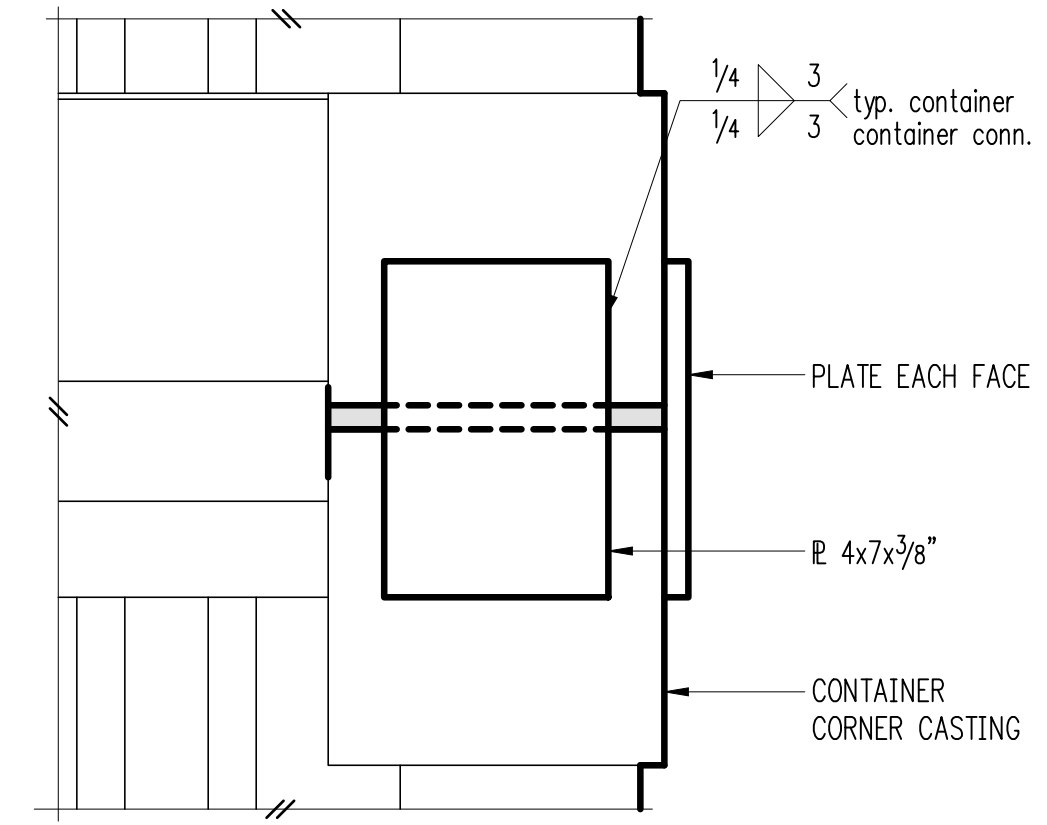

3" = 1'-0"
Cont. -To- Cont. Corner Connection 8

INTERMEDIATE CONNECTION AT SIM WITH PLATE ON FRONT FACE ONLY

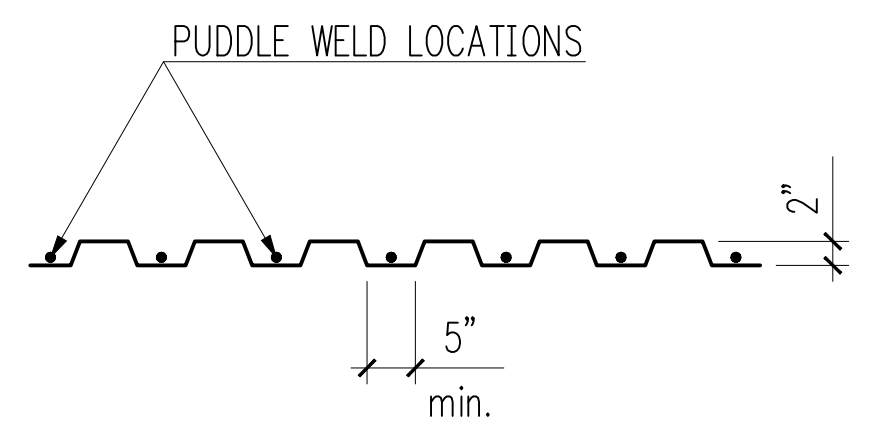

Verco ASC DG 2W-36, G60 Galvanized w/Following Min. Properties

22 GA.
 I = +0.377 in⁴
 S = +0.355 in.³
 Fy = 38 ksi

1. MAXIMUM DECK SPAN = 10'-0" c. TO c. (TWO OR MORE CONTINUOUS SPANS).
2. PROVIDE (4) 1/2" DIAMETER PUDDLE WELDS PER SHEET TO ALL SUPPORTS PERPENDICULAR TO DECK FLUTES.
3. PROVIDE 1/2" DIAMETER PUDDLE WELDS AT 12"oc TO ALL STRUTS PARALLEL SUPPORTS PARALLEL TO DECK FLUTES.
4. CONNECT DECK SEAMS WITH BUTTON PUNCHES @ 12"oc.
5. DECK TYPE MUST STRICTLY MEET CRITERIA LISTED ABOVE INCLUDING RESEARCH REPORT ALLOWABLE SHEAR LOADS. SUBMIT DECK INFORMATION TO ENGINEER PRIOR TO BEGINNING SHOP DRAWINGS.

1" = 1'-0"
2" Floor Deck 10

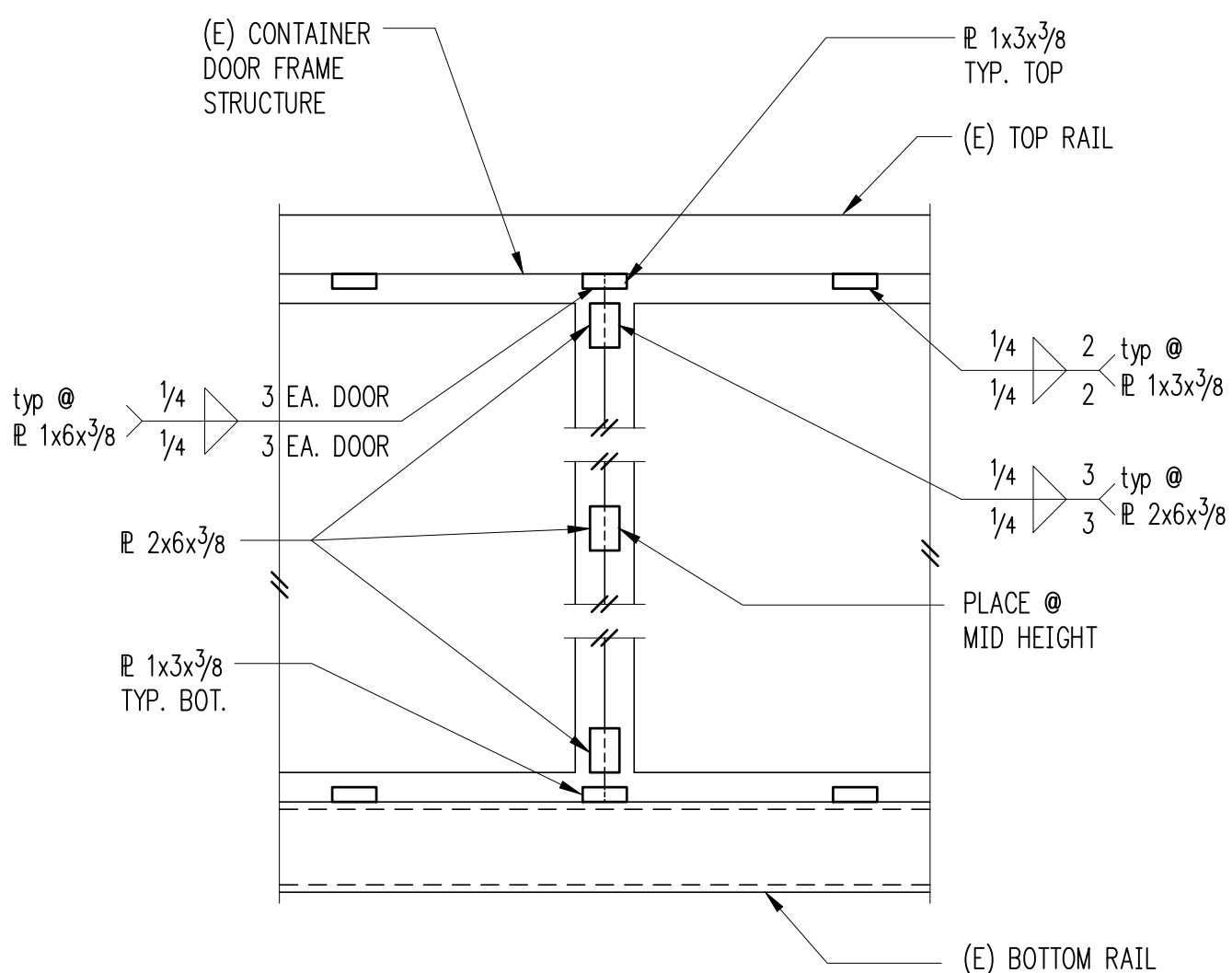

1" = 1'-0"
Container Door Welding 11

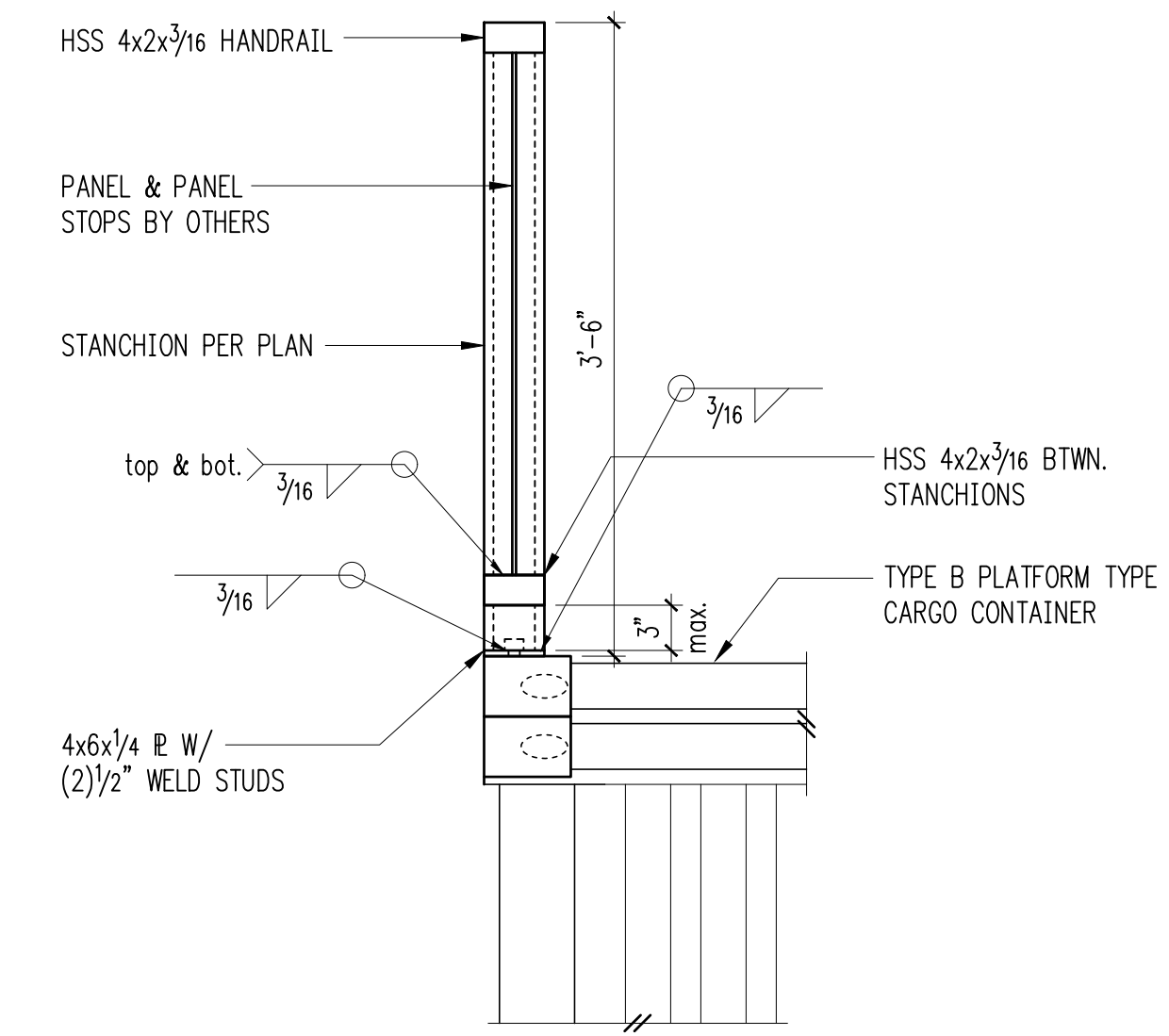

1" = 1'-0"
Handrail Stanchions Connection at Deck 12

