

LUTHER BURBANK PARK COMPREHENSIVE WATERFRONT IMPROVEMENTS CITY OF MERCER ISLAND PUBLIC WORKS DEPARTMENT

SHEET INDEX

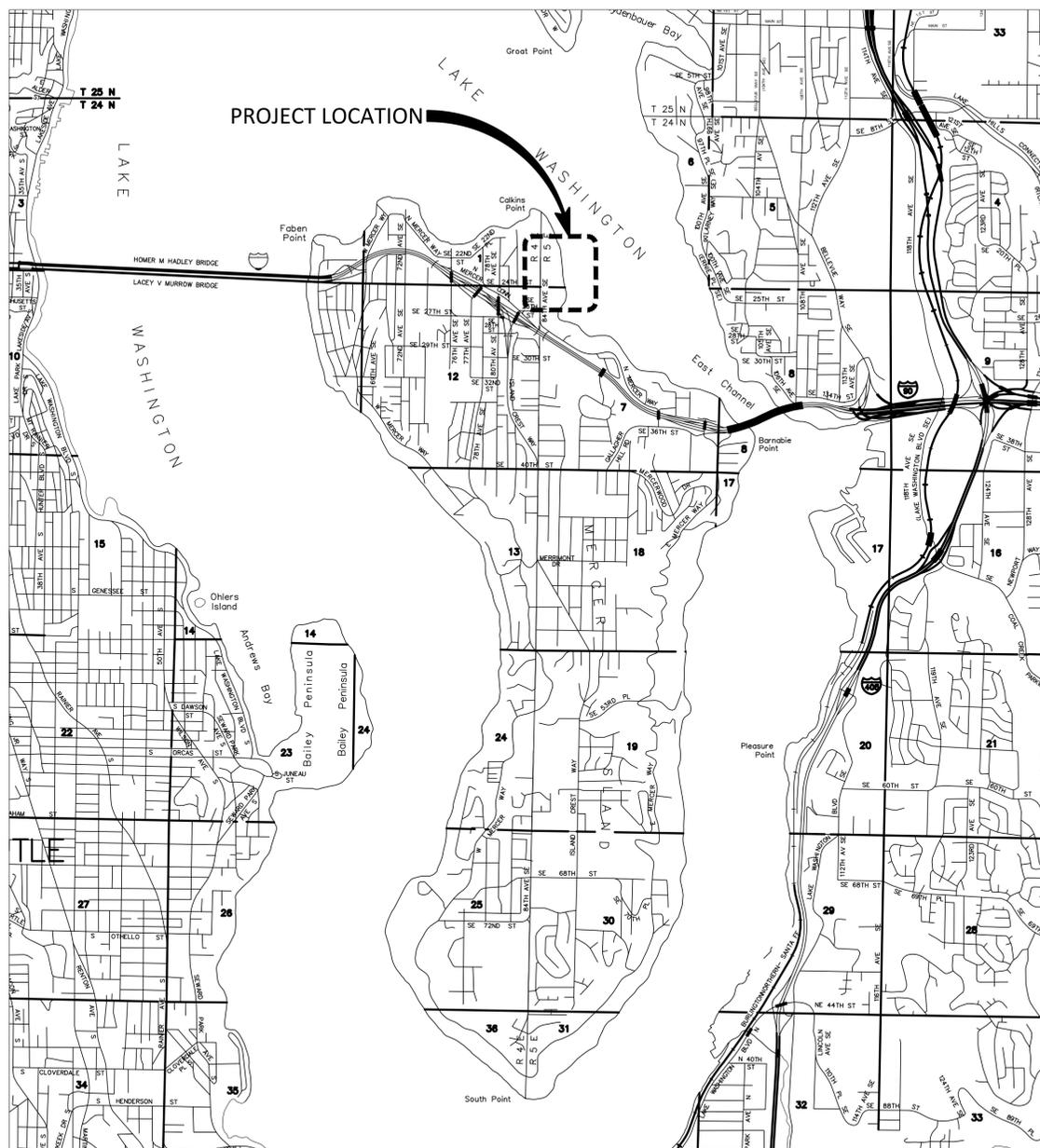

VICINITY MAP

OWNER
 CITY OF MERCER ISLAND PUBLIC WORKS DEPARTMENT
 9611 SE 36TH STREET
 MERCER ISLAND, WA 98040

PROJECT ADDRESS
 2048 84TH AVE SE
 MERCER ISLAND, WA 98040

PROJECT CONTACT
 PAUL WEST
 (206) 677-1028
 paul.west@mercerisland.gov

SHEET #	DRAWING	TITLE
1	G-001	COVER SHEET
2	G-002	PROJECT GENERAL NOTES
3	G-003	TEMPORARY ACCESS PLAN
4	G-010	EXISTING CONDITIONS SITE PLAN
5	G-020	OVERALL SITE IMPROVEMENT AND SURFACING PLAN
6	D-010	DEMO AND TESC SITE PLAN - 1
7	D-011	DEMO AND TESC SITE PLAN - 2
8	D-012	TESC DETAILS
9	C-010	ENLARGED PLAN - STORM DRAIN
10	C-011	STORM DRAIN DETAILS
11	C-012	SILVA CELL DETAIL
12	C-020	GRADING PLAN-1
13	C-021	GRADING PLAN-2
14	C-022	GRADING PLAN-3
15	C-023	GRADING PLAN-4
16	C-024	GRADING DETAILS - NOT USED
17	C-030	UTILITY PLAN - OVERALL
18	C-031	UTILITY PLAN - 1
19	C-032	UTILITY PLAN - 2
20	C-033	UTILITY PLAN - 3
21	C-034	UTILITY PLAN - 4
22	C-035	UTILITY DETAILS
23	C-036	UTILITY DETAILS
24	C-037	UTILITY DETAILS
25	G-021	COMPOSITE SITE PLAN - 1
26	G-022	COMPOSITE SITE PLAN - 2
27	CU-010	INTAKE AND PUMPING FACILITIES - OVERALL SITE PLAN
28	CU-011	INTAKE AND PUMPING FACILITIES - EQUIPMENT PLAN AND SECTIONS (1 OF 2)
29	CU-012	INTAKE AND PUMPING FACILITIES - EQUIPMENT PLAN AND SECTIONS (2 OF 2)
30	CU-013	INTAKE AND PUMPING FACILITIES - DETAILS
31	CM-010	MATERIALS PLAN
32	CM-011	CONSTRUCTION MATERIALS CROSS-SECTIONS
33	CM-012	CONSTRUCTION MATERIALS DETAILS (SHEET 1 OF 4)
34	CM-013	CONSTRUCTION MATERIALS DETAILS (SHEET 2 OF 4)
35	CM-014	CONSTRUCTION MATERIALS DETAILS (SHEET 3 OF 4)
36	CM-015	CONSTRUCTION MATERIALS DETAILS (SHEET 4 OF 4)
37	L-010	PLANTING PLAN
38	L-011	PLANT SCHEDULE
39	L-012	PLANTING DETAILS
40	S-001	STRUCTURAL NOTES
41	S-002	STRUCTURAL NOTES
42	S-003	STATEMENT OF SPECIAL INSPECTIONS
43	S-010	PIER IMPROVEMENT PLAN
44	S-011	ENLARGED PIER REPAIR PLAN
45	S-012	FLOATS PLAN
46	S-020	GRATED OVERWATER PLATFORM DETAILS
47	S-021	PIER AND FLOATS ELEVATION
48	S-022	PIER AND FLOATS ELEVATION
49	S-030	FIXED PIER EXISTING CONDITIONS 1
50	S-031	FIXED PIER EXISTING CONDITIONS 2
51	S-032	FIXED PIER EXISTING CONDITIONS 3
52	S-040	FIXED PIER REPAIR DETAILS
53	S-041	FIXED PIER REPAIR DETAILS
54	S-042	FIXED PIER GRATING DETAILS
55	S-050	FLOAT DETAILS
56	S-060	VIEWING DECK ELEVATED ACCESS PATH

CAD USER: RICKT PLOT DATE: Apr 12, 2023-10:59am
 PATH: V:\2000291 (Luther Burbank Pier Repairs)\02_Design (v2019)\LBPR_G-001.dwg

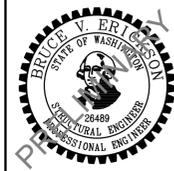

NO.	DATE	BY	REVISION
1	4/14/2023	WBC	LAND USE PERMIT REVISION
1A	4/14/2023		MIFD COMMENT REVISION



LUTHER BURBANK PARK
 WATERFRONT IMPROVEMENTS

COVER SHEET

DRAWN: RRT	PROJECT NO.: 2200248
DESIGN: WBC	SCALE: AS SHOWN
CHECKED: AKB	DATE: 10/7/2022
DRAWING NO.	G-001
SHEET NO.	1 OF 56

60% SUBMITTAL

PROJECT GENERAL NOTES

1. UNLESS NOTED OTHERWISE CONTRACTOR SHALL FOLLOW THE WSDOT SPECIFICATIONS FOR ROAD, BRIDGE AND MUNICIPAL CONSTRUCTION (2018).
2. DATUM:
 - A. VERTICAL DATUM: NAVD 88, OLWM: 16.75, OHWM: 18.67
 - B. HORIZONTAL DATUM: NAD83
3. BOUNDARY SURVEY: TOPOGRAPHIC SURVEY AND CONTROL PROVIDED BY KPFF IN AUGUST OF 2020, ADDITIONAL SURVEY COMPLETED IN JUNE 2022 AND JANUARY 2023.
4. BATHYMETRY: BATHYMETRIC CONTOURS COLLECTED BY WILSON ENGINEERING.
5. EXISTING STRUCTURES:
 - A. CONTRACTOR SHALL FIELD VERIFY ALL DIMENSIONS OF EXISTING STRUCTURES THAT MAY IMPACT THE WORK.
 - B. CONTRACTOR SHALL COORDINATE WITH THE ENGINEER, IF THERE ARE ANY CONFLICTS BETWEEN PROPOSED WORK AND EXISTING STRUCTURES TO REMAIN ON-SITE.
6. UTILITIES:
 - A. CONTRACTOR SHALL UTILIZE A UTILITY LOCATE SERVICE TO IDENTIFY UNDERGROUND UTILITIES, AT LEAST 48 HOURS PRIOR TO CONSTRUCTION AT THE SITE.
 - B. CONTRACTOR SHALL PROTECT-IN-PLACE ALL UTILITIES THAT ARE NOT INDICATED FOR DEMOLITION.
 - C. ANY DAMAGE TO EXISTING UTILITIES, FACILITIES OR EQUIPMENT, EXCEPT ITEMS TO BE DEMOLISHED, SHALL BE REPAIRED BY AND AT THE EXPENSE OF THE CONTRACTOR.
 - D. EXISTING BURIED WATER AND SANITARY UTILITIES CURRENTLY AT UNKNOWN LOCATIONS. CONTRACTOR SHALL BE RESPONSIBLE FOR LOCATING ALL UNKNOWN UTILITIES IN UPLAND AREA PRIOR TO ANY TEMPORARY UTILITY RE-ROUTE IMPLEMENTATION.
 - E. CONTRACTOR SHALL COORDINATE WITH THE ENGINEER AND OWNER FOR ALL MAINTAINED UTILITY SERVICES INCLUDING, BUT NOT LIMITED TO EXISTING STORM DRAINAGE, WATER AND ELECTRICAL LINES. IF NEEDED CONTRACTOR SHALL COORDINATE THE ACTIVATION AND DE-ACTIVATION OF UTILITIES WITH THE ENGINEER AND OWNER. CONTRACTOR SHALL PROVIDE A MINIMUM OF 2 DAYS ADVANCE WRITTEN NOTICE TO THE ENGINEER AND OWNER.
7. TRAFFIC CONTROL:
 - A. CONTRACTOR SHALL BE RESPONSIBLE FOR ANY VEHICULAR OR PEDESTRIAN TRAFFIC CONTROL REQUIRED DURING THE PROJECT. ALL TRAFFIC CONTROL SHALL BE IN ACCORDANCE TO THE MANUAL OF UNIFORM TRAFFIC CONTROL DEVICES (MUTCD).
8. IN WATER WORK:
 - A. CONTRACTOR SHALL LOCATE ALL EQUIPMENT WITHIN PROJECT WORK AREA LIMITS.
 - B. IN WATER WORK SHALL BE COMPLETED IN ACCORDANCE WITH THE PROJECT PERMITS.
9. STORMWATER POLLUTION PREVENTION PLAN (SWPPP):
 - A. CONTRACTOR SHALL PROVIDE THE SWPPP.

CODES AND DESIGN CRITERIA:

1. STORM DRAINAGE:
 - A. STORM DRAINAGE SYSTEM IS DESIGNED USING AND SHALL CONFORM TO THE 2014 DEPARTMENT OF ECOLOGY STORM WATER MANUAL.
 - B. CONTRACTOR SHALL BE RESPONSIBLE FOR RE-ROUTING STORMWATER DURING CONSTRUCTION.
 - C. CONTRACTOR SHALL PROVIDE ALL PUMPS, TANKS, PIPES, HOSES, APPURTENANCES AND POWER TO COLLECT AND DISCHARGE THE STORMWATER DURING CONSTRUCTION ACTIVITIES.
2. FIRE PROTECTION SYSTEM:
 - A. THE FIRE PROTECTION SYSTEM INCLUDING PIPES AND APPURTENANCES SHALL CONFORM TO THE 2018 VERSION OF THE INTERNATIONAL FIRE CODE, PARTICULARLY CHAPTER 36 – MARINAS AND BOATYARDS. THE FIRE SYSTEM SHALL ALSO CONFORM TO THE 2019 EDITION OF THE NFPA 14 FOR THE INSTALLATION OF STANDPIPES AND HOSE SYSTEMS. WHERE THERE IS CONFLICT THE SEATTLE FIRE CODE SHALL BE ADHERED TO.
 - B. PORTABLE FIRE EXTINGUISHERS WITH A MINIMUM RATING OF 2A 20-BC SHALL BE PLACED ON THE DOCK AND FLOAT AT EACH STANDPIPE LOCATION AND ADDITIONALLY SUCH THAT NO PORTION OF THE FLOAT MORE THAN 75 FEET FROM AN EXTINGUISHER.
 - C. A SIGN AT DOCK STATING THE FOLLOWING IS REQUIRED: LOCATIONS OF FIRST AID FACILITIES, TELEPHONES, FIRE FIGHTING EQUIPMENT, EMERGENCY EQUIPMENT, AND FIRE EXITS. A SIGN SHOULD ALSO INCLUDE TELEPHONE NUMBERS OF CLOSE AMBULANCE SERVICE, HOSPITAL, POLICE, AND FIRE DEPARTMENT.
 - D. FOR FIRE PROTECTION ON FLOAT, ABOVE WATER LEVEL PIPING SHALL BE GALVANIZED STEEL OF THE SIZE SHOWN IN THE DRAWINGS.
 - E. FOR FIRE PROTECTION ON FLOAT, BELOW WATER LEVEL PIPING SHALL BE HDPE OF A PRESSURE CLASS TO WITHSTAND THE REQUIREMENTS OF THE FIRE CODE.
 - F. FIRE SUPPRESSION SYSTEM SHALL CONSIST OF 6"Ø PIPING IN A DRY SYSTEM UNLESS NOTED OTHERWISE IN PLAN.

CAD USER: dgilbert PLOT DATE: Apr 13, 2023-02:23pm
 PATH: \\kpff\Projects\2020\20000291 Luther Burbank Park\Drawings\Current (DWG2018)\G-002 PROJECT GENERAL NOTES.dwg



NO.	DATE	BY	REVISION
1	4/14/2023	ROL	LAND USE PERMIT REVISION
1A	4/14/2023	ROL	MFD COMMENT REVISION



LUTHER BURBANK PARK
 WATERFRONT IMPROVEMENTS

PROJECT GENERAL NOTES

DRAWN: AS	PROJECT NO.: 2200248
DESIGN: SS	SCALE: AS SHOWN
CHECKED: NAW	DATE: 10/07/2022
DRAWING NO.	G-002
SHEET NO.	02 of 56

60% SUBMITTAL

CAD USER: dgilbert PLOT DATE: Apr 13, 2023-02:23pm
 PATH: \\kpf\proj\Projects\2020\20000291 Luther Burbank Park\Drawings\Current (DWG2018)\G-003 TEMPORARY ACCESS AND STAGING PLAN.dwg

© 2022 Microsoft



kpff
 1601 5th Avenue, Suite 1600
 Seattle, WA 98101
 206.622.5822
 www.kpff.com

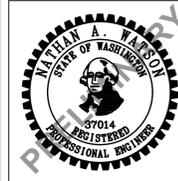

NO.	DATE	BY	REVISION
1A	4/14/2023	ROL	MIFD COMMENT REVISION



LUTHER BURBANK PARK
 WATERFRONT IMPROVEMENTS

TEMPORARY ACCESS PLAN

DRAWN: AS	PROJECT NO.: 2200248
DESIGN: SS	SCALE: 1" = 100'
CHECKED: NAW	DATE: 10/07/2022
DRAWING NO.	G-003
SHEET NO.	03 of 56

60% SUBMITTAL

CAD USER: dgilbert PLOT DATE: Apr 13, 2023-02:23pm
 PATH: \\kpf\proj\Projects\2020\20000291 Luther Burbank Park\Drawings\Current (DWG2018)\G-010 EXISTING CONDITIONS SITE PLAN.dwg



1601 5th Avenue, Suite 1600
 Seattle, WA 98101
 206.622.5822
 www.kpff.com



NO.	DATE	BY	REVISION
1	4/14/2023	ROL	LAND USE PERMIT REVISION
1A	4/14/2023	ROL	MIFD COMMENT REVISION



LUTHER BURBANK PARK
WATERFRONT IMPROVEMENTS
 EXISTING CONDITIONS SITE PLAN

DRAWN: AS	PROJECT NO.: 2200248
DESIGN: SS	SCALE: 1" = 30'
CHECKED: NAW	DATE: 10/07/2022
DRAWING NO.	G-010
SHEET NO.	04 of 56

60% SUBMITTAL

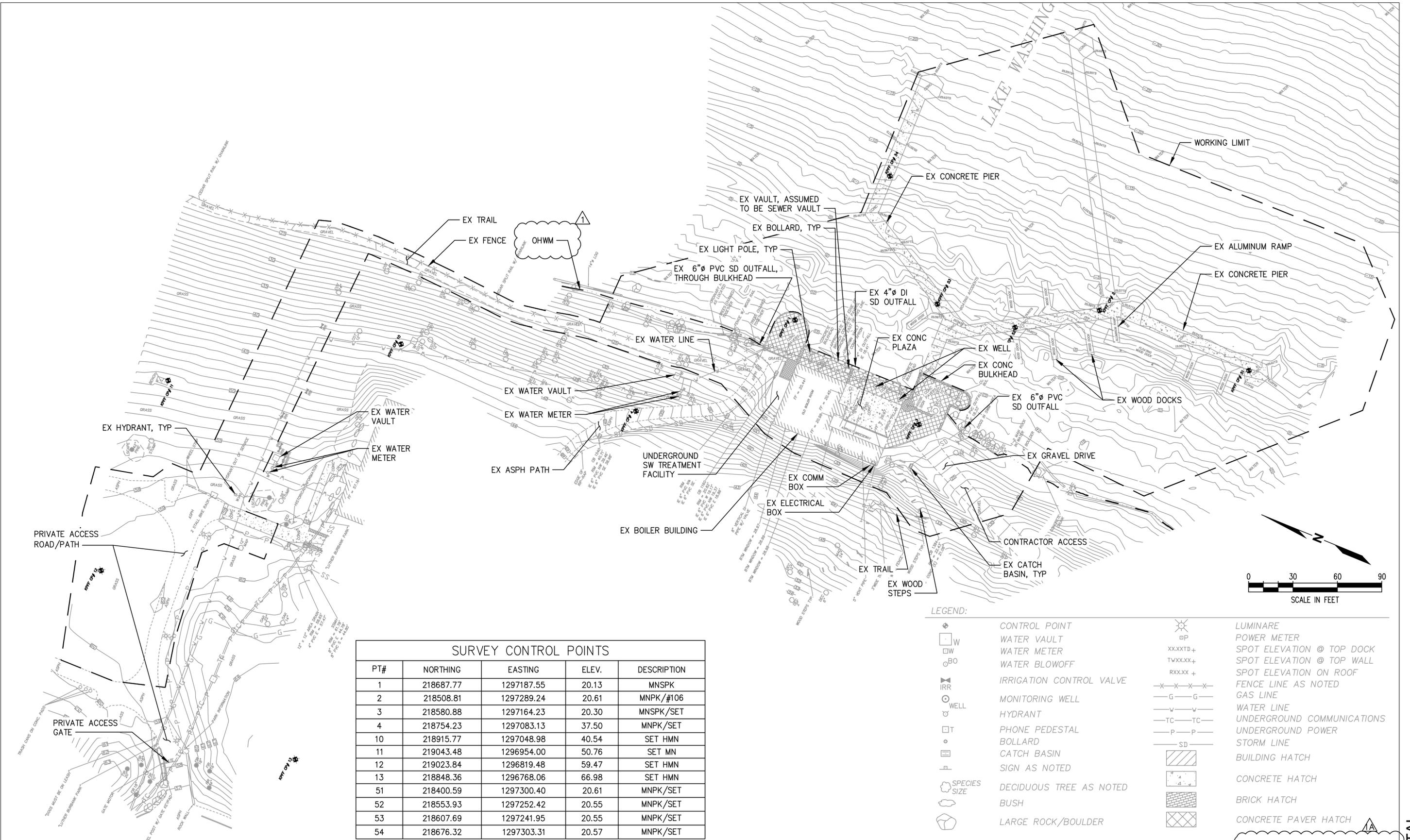

SURVEY CONTROL POINTS				
PT#	NORTHING	EASTING	ELEV.	DESCRIPTION
1	218687.77	1297187.55	20.13	MNSPK
2	218508.81	1297289.24	20.61	MNPK/#106
3	218580.88	1297164.23	20.30	MNSPK/SET
4	218754.23	1297083.13	37.50	MNPK/SET
10	218915.77	1297048.98	40.54	SET HMN
11	219043.48	1296954.00	50.76	SET MN
12	219023.84	1296819.48	59.47	SET HMN
13	218848.36	1296768.06	66.98	SET HMN
51	218400.59	1297300.40	20.61	MNPK/SET
52	218553.93	1297252.42	20.55	MNPK/SET
53	218607.69	1297241.95	20.55	MNPK/SET
54	218676.32	1297303.31	20.57	MNPK/SET

LEGEND:

	CONTROL POINT		LUMINARE
	WATER VAULT		POWER METER
	WATER METER		SPOT ELEVATION @ TOP DOCK
	WATER BLOWOFF		SPOT ELEVATION @ TOP WALL
	IRRIGATION CONTROL VALVE		SPOT ELEVATION ON ROOF
	MONITORING WELL		FENCE LINE AS NOTED
	HYDRANT		GAS LINE
	PHONE PEDESTAL		WATER LINE
	BOLLARD		UNDERGROUND COMMUNICATIONS
	CATCH BASIN		UNDERGROUND POWER
	SIGN AS NOTED		STORM LINE
	DECIDUOUS TREE AS NOTED		BUILDING HATCH
	BUSH		CONCRETE HATCH
	LARGE ROCK/BOULDER		BRICK HATCH
			CONCRETE PAVER HATCH

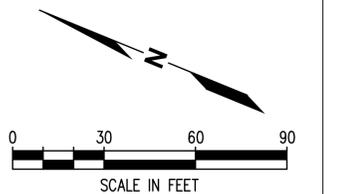

CAD USER: dgilbert PLOT DATE: Apr 13, 2023-02:23pm
 PATH: \\kpf\itac\Projects\2020\20000291 Luther Burbank Park\Drawings\Current (DWG2018)\G-020 OVERALL SITE AND SURFACING PLAN.dwg

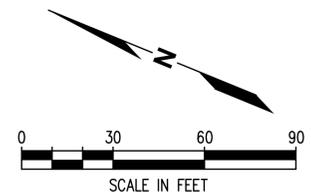
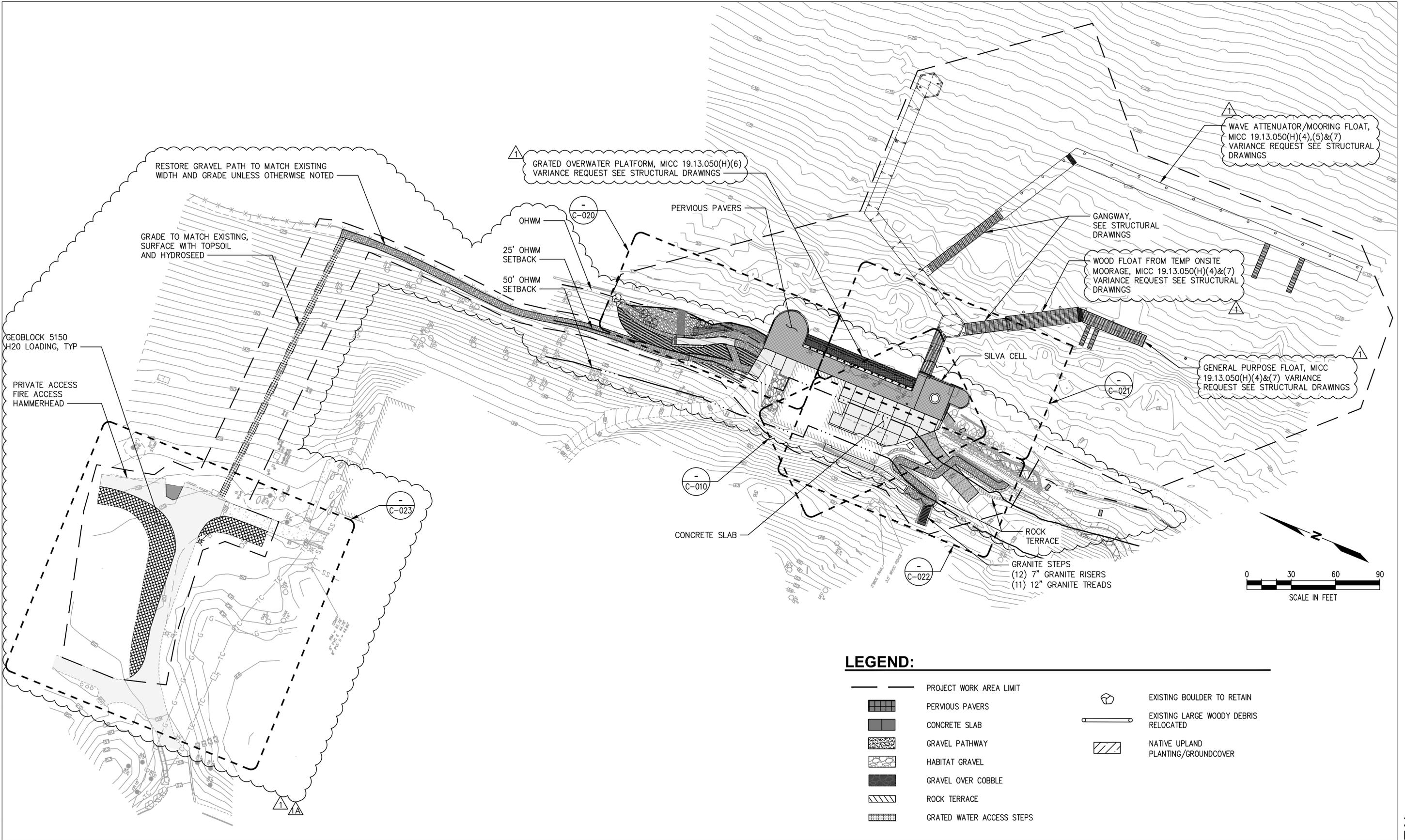

LEGEND:

- PROJECT WORK AREA LIMIT
- PERVIOUS PAVERS
- CONCRETE SLAB
- GRAVEL PATHWAY
- HABITAT GRAVEL
- GRAVEL OVER COBBLE
- ROCK TERRACE
- GRATED WATER ACCESS STEPS
- EXISTING BOULDER TO RETAIN
- EXISTING LARGE WOODY DEBRIS RELOCATED
- NATIVE UPLAND PLANTING/GROUNDCOVER



1601 5th Avenue, Suite 1600
 Seattle, WA 98101
 206.622.5822
 www.kpff.com



NO.	DATE	BY	REVISION
1	4/14/2023	ROL	LAND USE PERMIT REVISION
1A	4/14/2023	ROL	MIFD COMMENT REVISION



**LUTHER BURBANK PARK
 WATERFRONT IMPROVEMENTS**

OVERALL SITE IMPROVEMENT AND SURFACING PLAN

DRAWN: AS	PROJECT NO.: 2200248
DESIGN: SS	SCALE: 1" = 20'
CHECKED: NAW	DATE: 10/07/2022
DRAWING NO.	G-020
SHEET NO.	05 of 56

60% SUBMITTAL



NOTES:

1. CONTRACTOR SHALL INSTALL TESC MEASURES BEFORE COMMENCEMENT OF ANY OTHER WORK ON SITE.
2. CONTRACTOR SHALL MAINTAIN ACCESS AND PROTECT WATER VALVES, MONITORING WELLS, OVERHEAD LIGHTS AND LIGHT POLES. CONTRACTOR SHALL REPAIR OR REPLACE ALL ITEMS DAMAGED DURING CONSTRUCTION.
3. ALL DEMOLISHED MATERIAL SHALL BECOME THE PROPERTY OF THE CONTRACTOR. CONTRACTOR SHALL BE RESPONSIBLE TO DISPOSE OF DEMOLISHED AND EXCAVATED MATERIAL AT A PERMITTED DISPOSAL FACILITY.
4. CONTRACTOR SHALL INSTALL TESC MEASURES BEFORE PAVEMENT REMOVAL AND EXCAVATION.
5. CONTRACTOR SHALL PROVIDE SWEEPING AS NEEDED.
6. CONTRACTOR SHALL COORDINATE WITH SITE OWNER TO DETERMINE AN APPROPRIATE STOCKPILE LAYDOWN AREA WITHIN PROJECT LIMITS. SEE DETAIL 2 ON SHEET D-012.
7. INLET PROTECTION SHALL BE PLACED IN ALL CATCH BASINS IN THE VICINITY OF THE PROPERTY LIMITS PRIOR TO THE COMMENCEMENT OF WORK AND MAINTAINED FOR THE DURATION OF THE PROJECT.
8. UPON COMPLETION OF PROJECT CONTRACTOR SHALL CLEAN AND RE-INSTALL INLET PROTECTION AND LEAVE IN PLACE WITHIN PROPERTY LIMITS.

LEGEND:

- OHWM LINE
- PROJECT WORK AREA LIMITS
- TEMPORARY FLOATING DEBRIS BOOM
- SILT FENCE 4 D-012
- INLET PROTECTION 3 D-012
- REMOVE TREE
- DEMOLISH CONCRETE/PAVERS
- DEMOLISH ASPHALT
- DEMOLISH WOOD DOCK

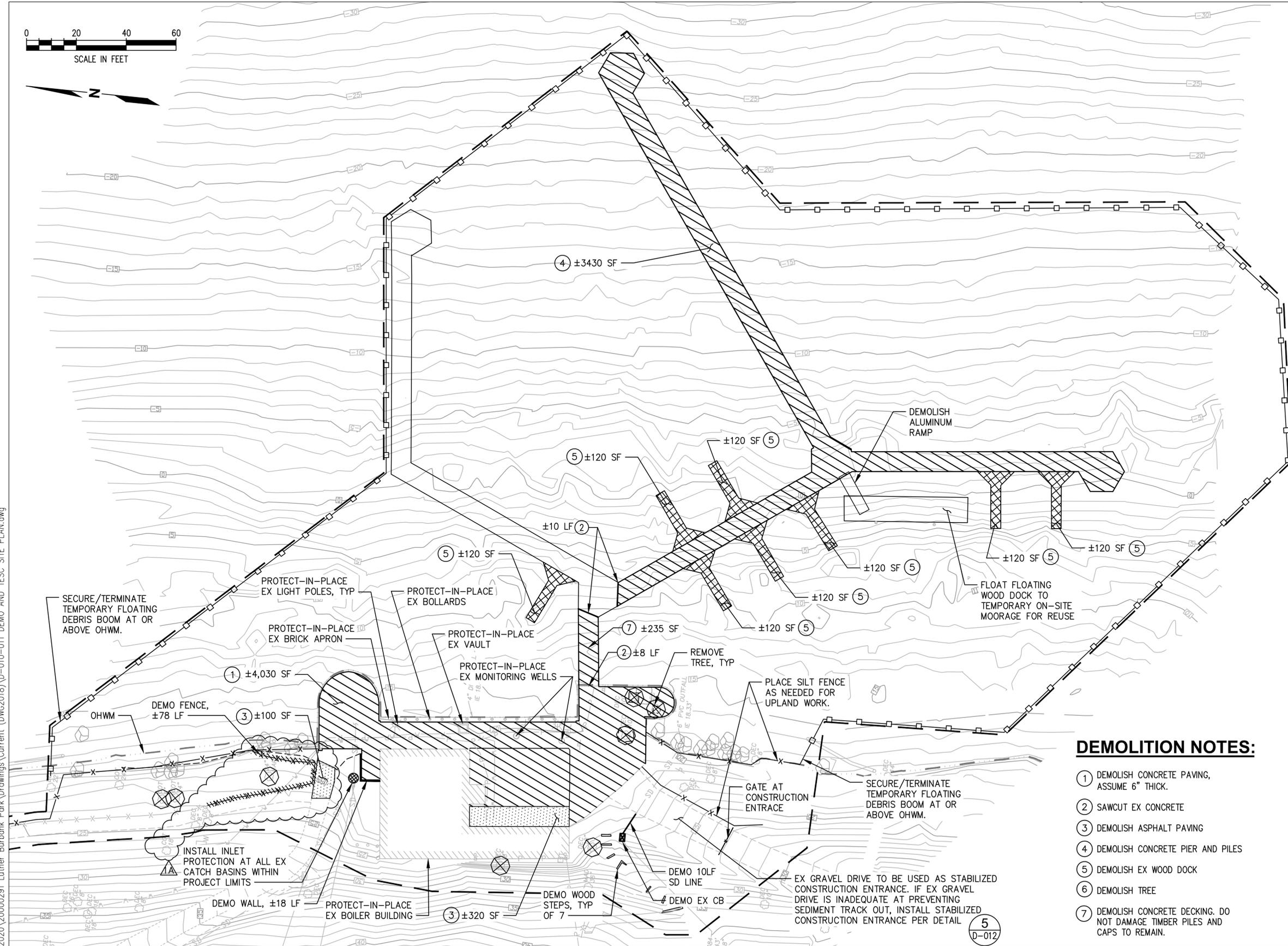

DEMOLITION NOTES:

- ① DEMOLISH CONCRETE PAVING, ASSUME 6" THICK.
- ② SAWCUT EX CONCRETE
- ③ DEMOLISH ASPHALT PAVING
- ④ DEMOLISH CONCRETE PIER AND PILES
- ⑤ DEMOLISH EX WOOD DOCK
- ⑥ DEMOLISH TREE
- ⑦ DEMOLISH CONCRETE DECKING. DO NOT DAMAGE TIMBER PILES AND CAPS TO REMAIN.

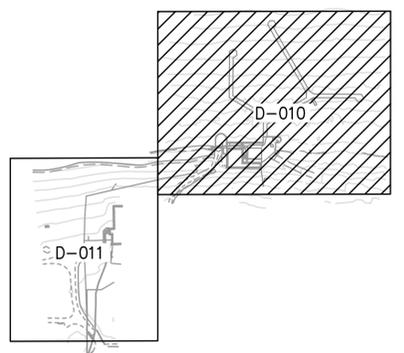

KEY PLAN

CAD USER: dgilbert PLOT DATE: Apr 13, 2023-02:23pm
 PATH: \\kpf\proj\Projects\2020\20000291 Luther Burbank Park\Drawings\Current (DWG2018)\D-010-011 DEMO AND TESC SITE PLAN.dwg



NO.	DATE	BY	REVISION
1A	4/14/2023	ROL	MIFD COMMENT REVISION



LUTHER BURBANK PARK
WATERFRONT IMPROVEMENTS

DEMO AND TESC SITE PLAN - 1

DRAWN: AS	PROJECT NO.: 2200248
DESIGN: SS	SCALE: 1" = 20'
CHECKED: NAW	DATE: 10/07/2022
DRAWING NO.	D-010
SHEET NO.	06 of 56

60% SUBMITTAL

CAD USER: dgilbert PLOT DATE: Apr 13, 2023-02:23pm
 PATH: \\kpf\proj\Projects\2020\20000291 Luther Burbank Park\Drawings\Current (DWG2018)\D-010-011 DEMO AND TESC SITE PLAN.dwg



1601 5th Avenue, Suite 1600
 Seattle, WA 98101
 206.622.5822
 www.kpff.com



NO.	DATE	BY	REVISION
1A	4/14/2023	ROL	MIFD COMMENT REVISION



LUTHER BURBANK PARK
 WATERFRONT IMPROVEMENTS

DEMO AND TESC SITE PLAN - 2

KEY PLAN

DRAWN: AS	PROJECT NO.: 2200248
DESIGN: SS	SCALE: 1" = 30'
CHECKED: NAW	DATE: 10/07/2022
DRAWING NO.	D-011
SHEET NO.	07 OF 56

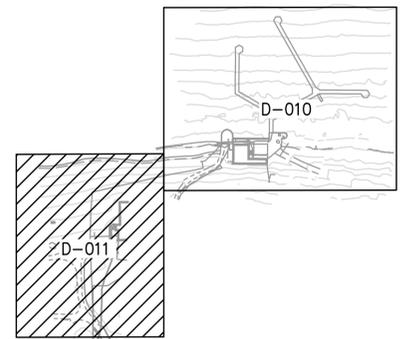
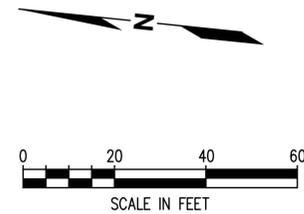
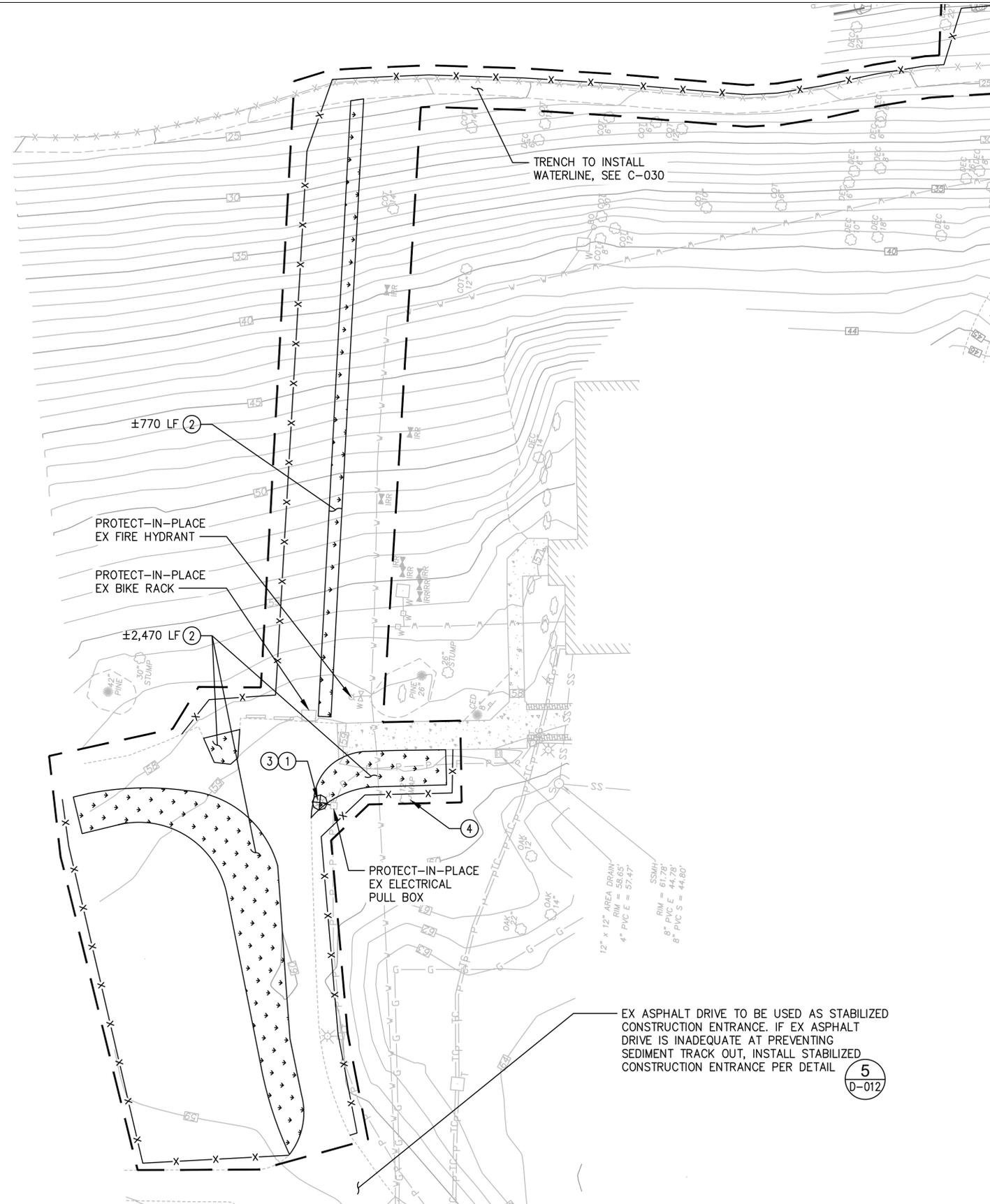

NOTES:

- CONTRACTOR SHALL INSTALL TESC MEASURES BEFORE COMMENCEMENT OF ANY OTHER WORK ON SITE.
- CONTRACTOR SHALL MAINTAIN ACCESS AND PROTECT WATER VALVES, MONITORING WELLS, OVERHEAD LIGHTS AND LIGHT POLES. CONTRACTOR SHALL REPAIR OR REPLACE ALL ITEMS DAMAGED DURING CONSTRUCTION.
- ALL DEMOLISHED MATERIAL SHALL BECOME THE PROPERTY OF THE CONTRACTOR. CONTRACTOR SHALL BE RESPONSIBLE TO DISPOSE OF DEMOLISHED AND EXCAVATED MATERIAL AT A PERMITTED DISPOSAL FACILITY.
- CONTRACTOR SHALL INSTALL TESC MEASURES BEFORE PAVEMENT REMOVAL AND EXCAVATION.
- CONTRACTOR SHALL PROVIDE SWEEPING AS NEEDED.
- CONTRACTOR SHALL COORDINATE WITH SITE OWNER TO DETERMINE AN APPROPRIATE STOCKPILE LAYDOWN AREA WITHIN PROJECT LIMITS. SEE DETAIL 2 ON SHEET D-012.
- INLET PROTECTION SHALL BE PLACED IN ALL CATCH BASINS IN THE VICINITY OF THE PROPERTY LIMITS PRIOR TO THE COMMENCEMENT OF WORK AND MAINTAINED FOR THE DURATION OF THE PROJECT.
- UPON COMPLETION OF PROJECT CONTRACTOR SHALL CLEAN AND RE-INSTALL INLET PROTECTION AND LEAVE IN PLACE WITHIN PROPERTY LIMITS.

LEGEND:

- — — — — OHWM LINE
- — — — — PROJECT WORK AREA LIMITS
- x-x-x-x-x SILT FENCE (4 D-012)
- ⊕ DEMOLISH ITEM
- ⬇ ⬇ ⬇ GRUB EX GRASS

DEMOLITION NOTES:

- ① SALVAGE EX LIGHT POLE
- ② GRUB EX SOD
- ③ DEMOLISH EX LIGHT POLE FOUNDATION
- ④ PROTECT IN PLACE EX MAPLE TREE, SOD AND SOIL REMOVAL IN ACCORDANCE WITH G-022

60% SUBMITTAL

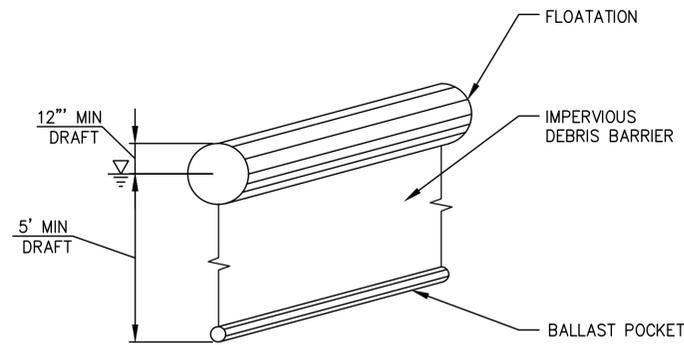

1 DEBRIS BOOM
NTS

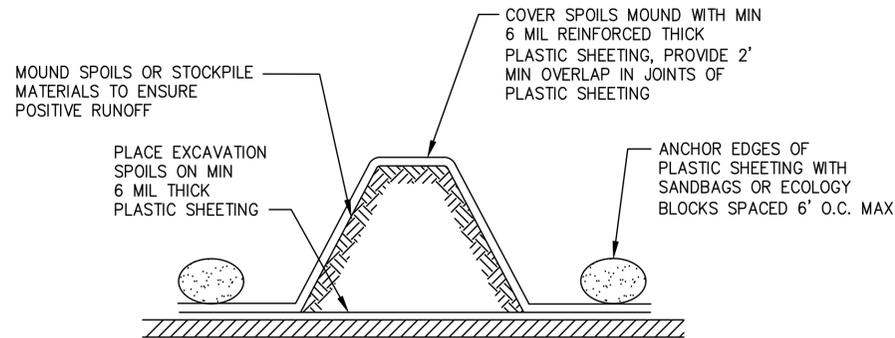

2 STOCKPILE PROTECTION DETAIL
NTS

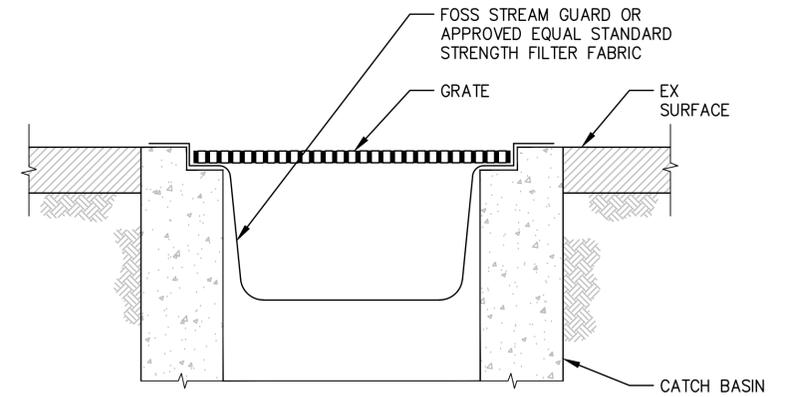

MAINTENANCE STANDARDS:

- EXISTING CATCH BASINS SHALL BE FITTED WITH FILTER FABRIC AS SHOWN.
- ANY ACCUMULATED SEDIMENT ON OR AROUND THE FILTER FABRIC SHALL BE REMOVED IMMEDIATELY. SEDIMENT SHALL NOT BE REMOVED BY FLUSHING WITH WATER. ALL SEDIMENT MUST BE DISPOSED OF OFF-SITE.

3 INLET PROTECTION DETAIL
NTS

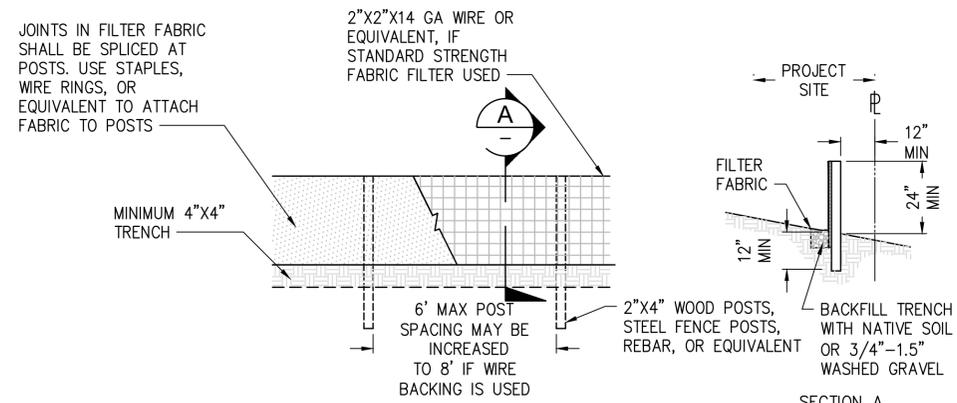

4 SILT FENCE
NTS

MAINTENANCE NOTES:

- REPAIR ANY DAMAGE IMMEDIATELY.
- IF CONCENTRATED FLOWS ARE EVIDENT UPHILL OF THE FENCE, INTERCEPT AND CONVEY THEM TO A SEDIMENT POND.
- IT IS IMPORTANT TO CHECK THE UPHILL SIDE OF THE FENCE FOR SIGNS OF THE FENCE CLOGGING, ACTING AS A BARRIER TO FLOW, AND THEN CAUSING CHANNELIZATION OF FLOWS PARALLEL TO THE FENCE. IF THIS OCCURS, REPLACE THE FENCE OR REMOVE THE TRAPPED SEDIMENT.
- REMOVE SEDIMENT DEPOSITS WHEN THE DEPOSIT REACHES APPROXIMATELY ONE-THIRD THE HEIGHT OF THE SILT FENCE, OR INSTALL A SECOND SILT FENCE.
- IF THE FILTER FABRIC (GEOTEXTILE) HAS DETERIORATED DUE TO ULTRAVIOLET BREAKDOWN, REPLACE IT.

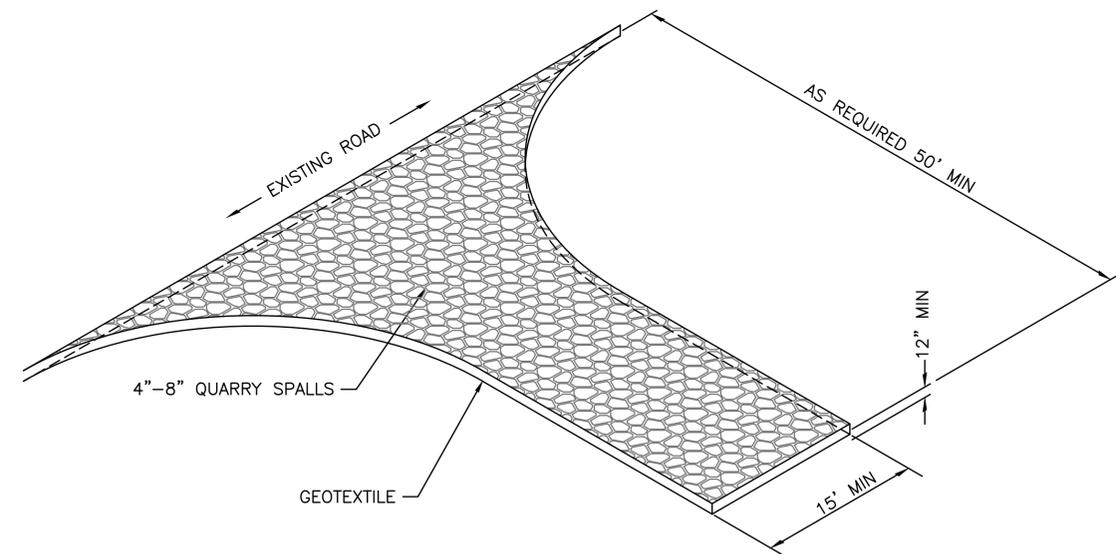

5 CONSTRUCTION ENTRANCE DETAIL
NTS

CAD USER: dgilbert PLOT DATE: Apr 13, 2023-02:24pm
 PATH: \\kpf\itac\Projects\2020\20000291 Luther Burbank Park\Drawings\Current (DWG2018)\D-012 TESC DETAILS.dwg



1601 5th Avenue, Suite 1600
 Seattle, WA 98101
 206.622.5822
 www.kpff.com



NO.	DATE	BY	REVISION
1A	4/14/2023	ROL	MIFD COMMENT REVISION



LUTHER BURBANK PARK
WATERFRONT IMPROVEMENTS

TESC DETAILS

DRAWN: AS	PROJECT NO.: 2200248
DESIGN: SS	SCALE: AS SHOWN
CHECKED: NAW	DATE: 10/07/2022
DRAWING NO.	D-012
SHEET NO.	08 of 56

60% SUBMITTAL

CAD USER: dgilbert PLOT DATE: Apr 13, 2023-02:36pm
 PATH: \\kpf\proj\Projects\2020\20000291\Luther Burbank Park\Drawings\Current (DWG2018)\C-010 ENLARGED PLAN - STORM DRAIN.dwg

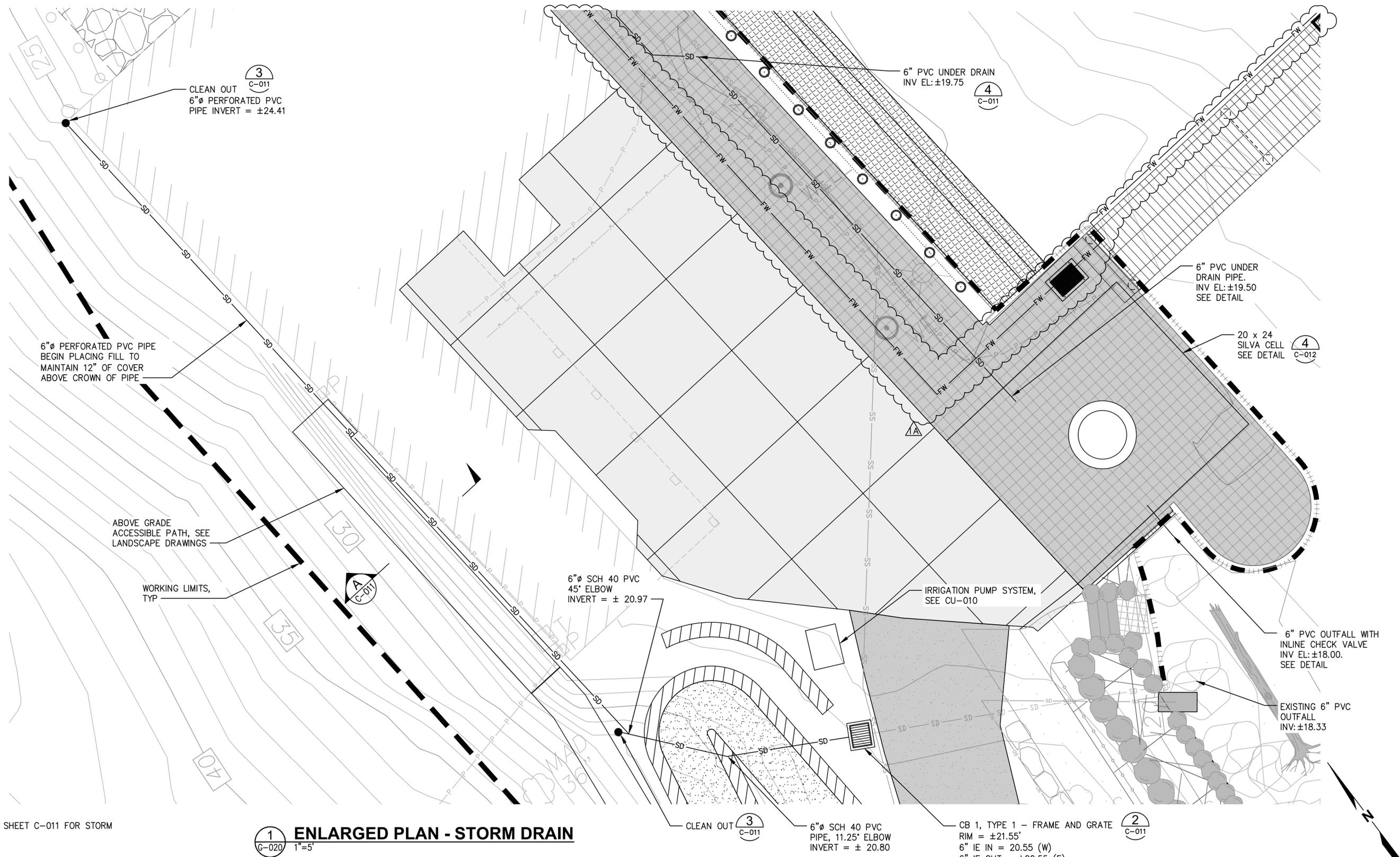

NOTES
 1. SEE SECTION B ON SHEET C-011 FOR STORM DRAIN PROFILE.

1 ENLARGED PLAN - STORM DRAIN
 C-020 1"=5'



1601 5th Avenue, Suite 1600
 Seattle, WA 98101
 206.622.5822
 www.kpff.com



NO.	DATE	BY	REVISION
1A	4/14/2023	ROL	MIFD COMMENT REVISION



LUTHER BURBANK PARK
WATERFRONT IMPROVEMENTS
 ENLARGED PLAN - STORM DRAIN

DRAWN: AS	PROJECT NO.: 2200248
DESIGN: SS	SCALE: 1" = 5'
CHECKED: NAW	DATE: 10/07/2022
DRAWING NO.	C-010
SHEET NO.	09 of 56

60% SUBMITTAL

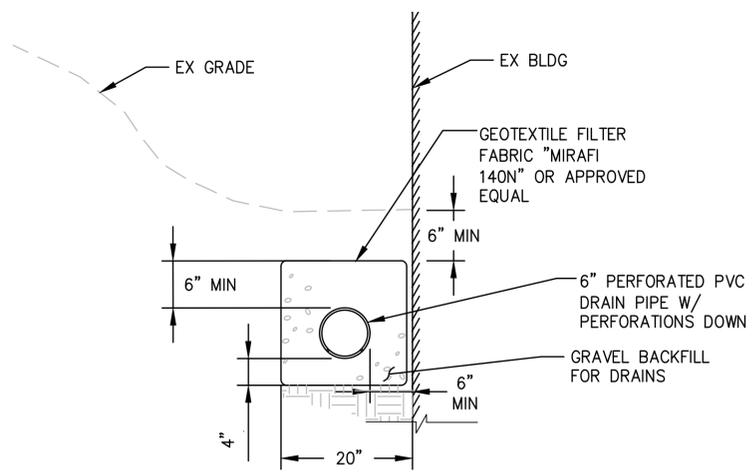

1
C-010 NTS
STORM DRAINAGE WALL AND FOOTING DRAIN SECTION

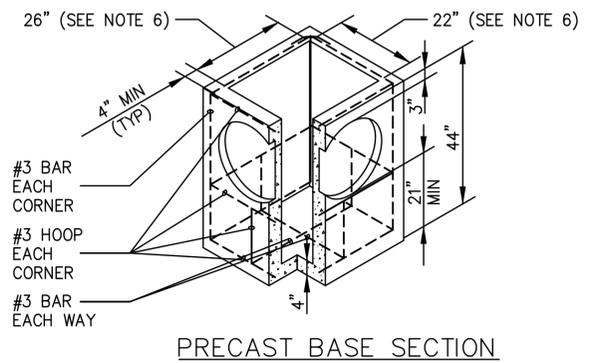
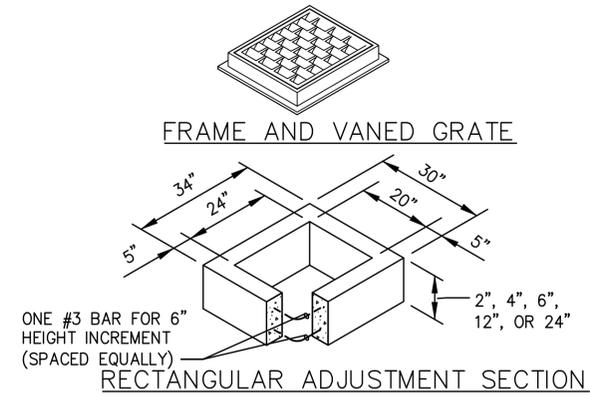

2
C-010 NTS
CATCH BASIN TYPE 1 DETAIL

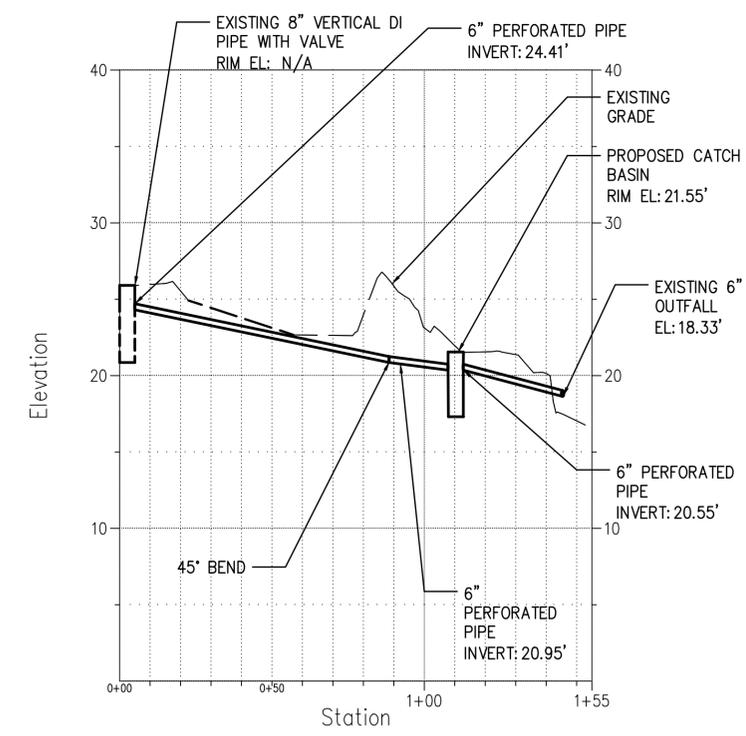

A
C-010 NTS
STORM DRAIN PROFILE

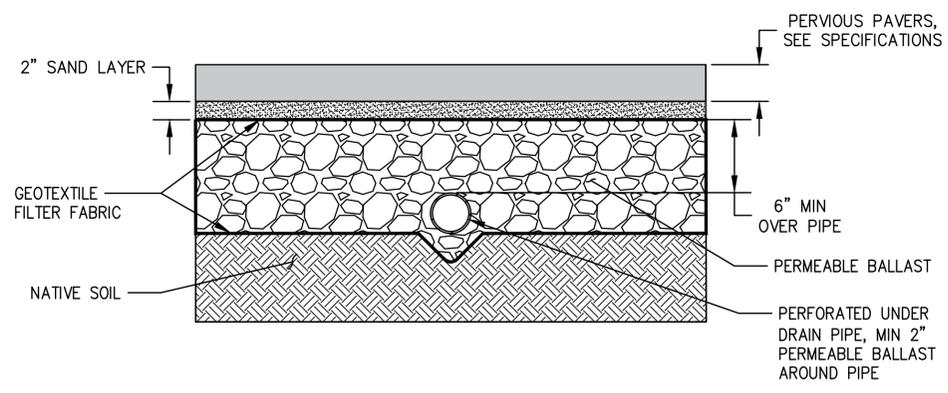

4
C-010 NTS
UNDERDRAIN DETAIL

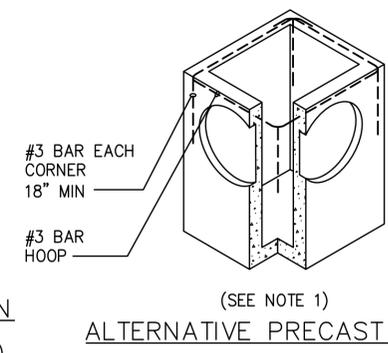

(SEE NOTE 1)

ALTERNATIVE PRECAST BASE SECTION

PIPE ALLOWANCES	
PIPE MATERIAL	MAXIMUM INSIDE DIAMETER
REINFORCED OR PLAIN CONCRETE	12"
ALL METAL PIPE	15"
CPSSP * (STD.SPEC.9-05.20)	12"
SOLID WALL PVC (STD.SPEC.9-05.12(1))	15"
PROFILE WALL PVC (STD.SPEC.9-05.12(2))	15"

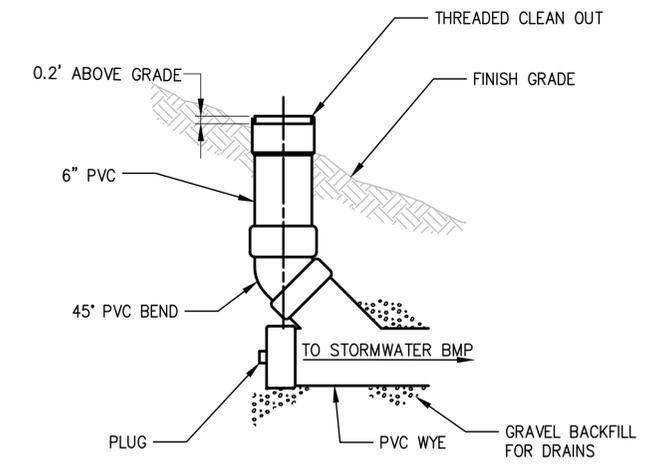

3
C-010 NTS
CLEAN OUT DETAIL

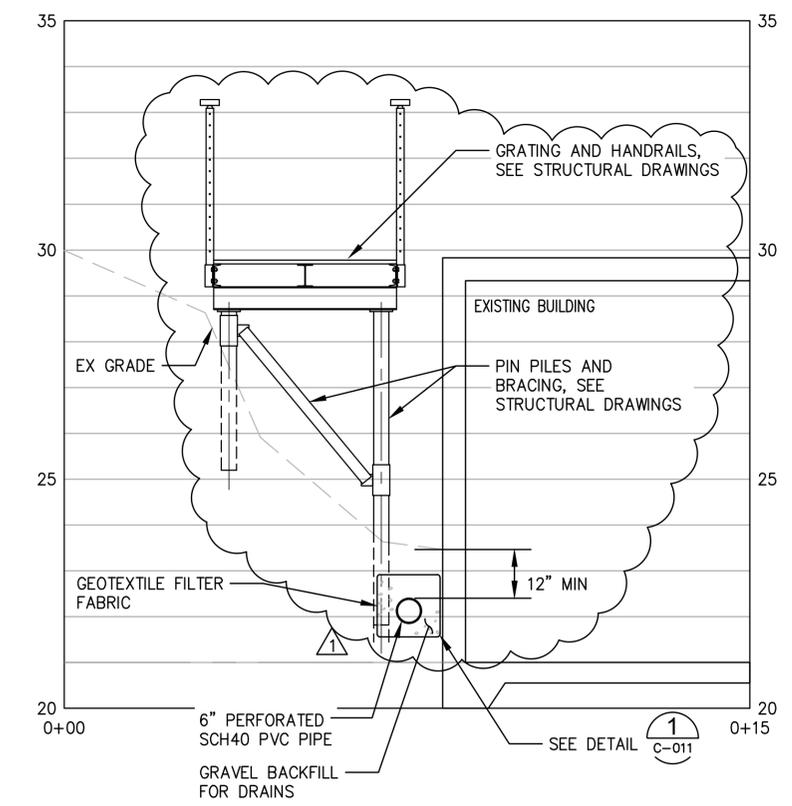

B
C-010 NTS
STORM DRAIN AND PATHWAY SECTION

CAD USER: dgilbert PLOT DATE: Apr 13, 2023-02:24pm PATH: \\kpf\proj\Projects\2020\20000291 Luther Burbank Park\Drawings\Current (DWG2018)\C-011 STORM DRAIN DETAILS.dwg



1601 5th Avenue, Suite 1600
Seattle, WA 98101
206.622.5822
www.kpff.com



NO.	DATE	BY	REVISION
1	4/14/2023	ROL	LAND USE PERMIT REVISION
1A	4/14/2023	ROL	MIFD COMMENT REVISION



LUTHER BURBANK PARK WATERFRONT IMPROVEMENTS

STORM DRAIN DETAILS

DRAWN: AS	PROJECT NO.: 2200248
DESIGN: SS	SCALE: AS SHOWN
CHECKED: NAW	DATE: 10/07/2022
DRAWING NO.	C-011
SHEET NO.	10 OF 56

60% SUBMITTAL

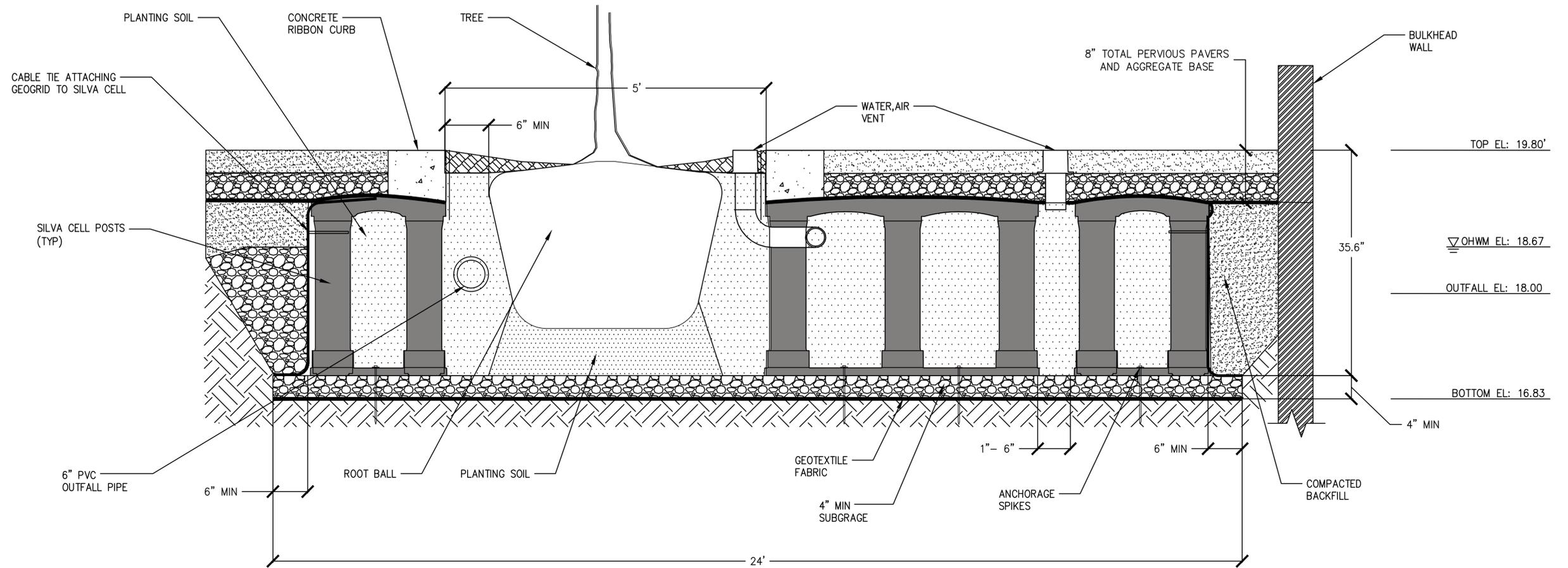

NOTES

- 1. SILVA CELL MAY CONTAIN X NUMBER OF TREES.

1 SILVA CELL DETAIL
C-010 NTS

CAD USER: dgilbert PLOT DATE: Apr 13, 2023-02:24pm
 PATH: \\kpf\proj\Projects\2020\20000291 Luther Burbank Park\Drawings\Current (DWG2018)\C-011 STORM DRAIN DETAILS.dwg



NO.	DATE	BY	REVISION
1	4/14/2023	ROL	LAND USE PERMIT REVISION
1A	4/14/2023	ROL	MIFD COMMENT REVISION



LUTHER BURBANK PARK
WATERFRONT IMPROVEMENTS

SILVA CELL DETAIL

DRAWN: AS	PROJECT NO.: 2200248
DESIGN: SS	SCALE: AS SHOWN
CHECKED: NAW	DATE: 10/07/2022
DRAWING NO.	C-012
SHEET NO.	11 OF 56

60% SUBMITTAL

CAD USER: dgilbert PLOT DATE: Apr 13, 2023-02:24pm
 PATH: \\kpf\office\Projects\2020\20000291 Luther Burbank Park\Drawings\Current (DWG2018)\C-020-023 GRADING PLAN (1-4). Updated.dwg

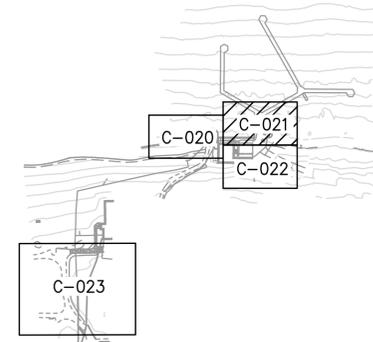
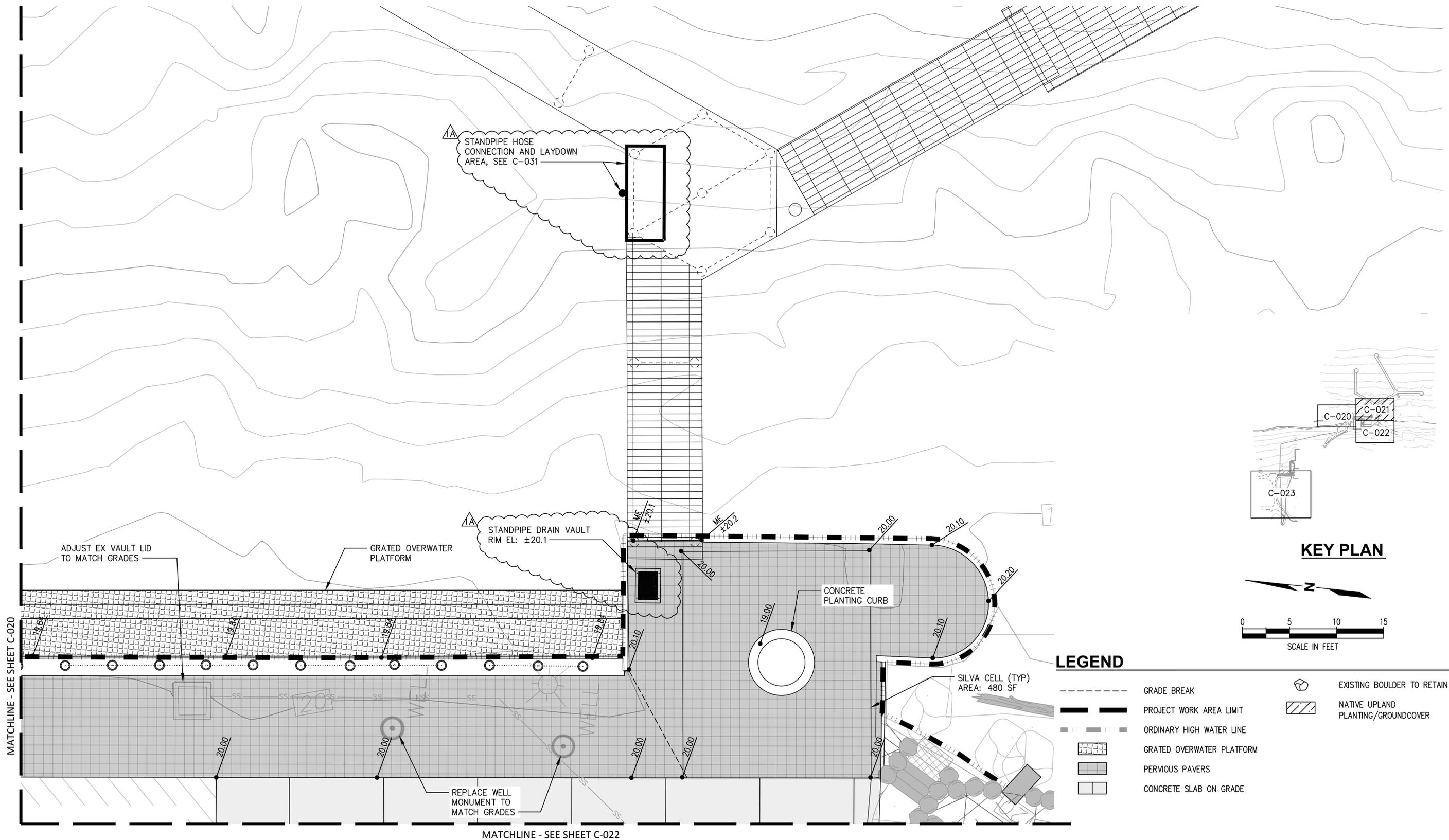

LEGEND

- GRADE BREAK
- PROJECT WORK AREA LIMIT
- ORDINARY HIGH WATER LINE
- [Grid Pattern] GRATED OVERWATER PLATFORM
- [Stippled Pattern] PERVIOUS PAVERS
- [Solid Grey] CONCRETE SLAB ON GRADE
- [Boulder Symbol] EXISTING BOULDER TO RETAIN
- [Hatched Pattern] NATIVE UPLAND PLANTING/GROUNDCOVER



NO.	DATE	BY	REVISION
1A	4/14/2023	ROL	MIFD COMMENT REVISION



LUTHER BURBANK PARK
 WATERFRONT IMPROVEMENTS

GRADING PLAN-2

DRAWN: AS	PROJECT NO.: 2200248
DESIGN: SS	SCALE: 1" = 5'
CHECKED: NAW	DATE: 10/07/2022
DRAWING NO.	C-021
SHEET NO.	13 of 56

60% SUBMITTAL

MATCHLINE - SEE SHEET C-021

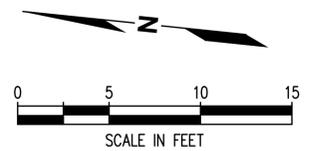
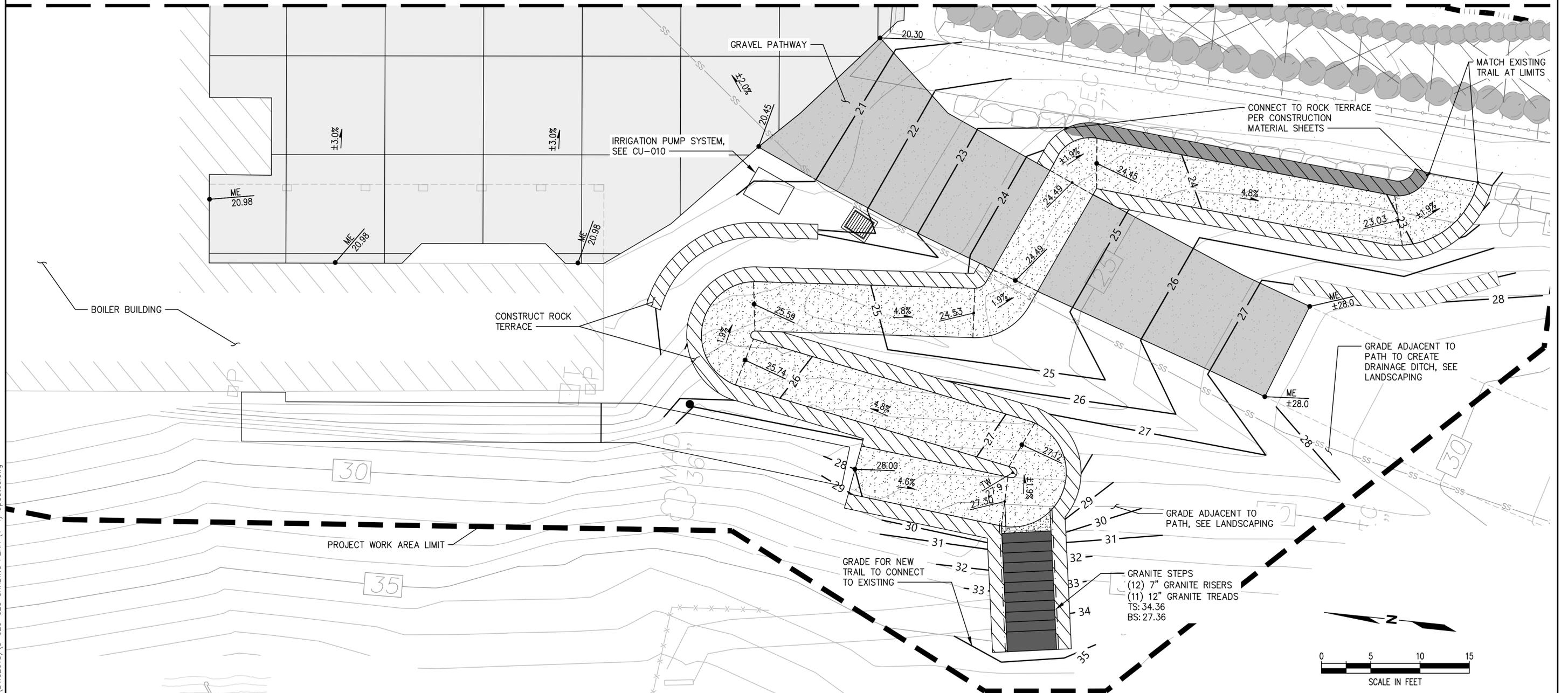

LEGEND

- GRADE BREAK
- PROJECT WORK AREA LIMIT
- ORDINARY HIGH WATER LINE
- CONCRETE SLAB ON GRADE
- GRAVEL PATHWAY
- ▨ GRATED WATER ACCESS STEPS
- BOULDER
- ▨ NATIVE UPLAND PLANTING/GROUNDCOVER
- ▨ ROCK TERRACE

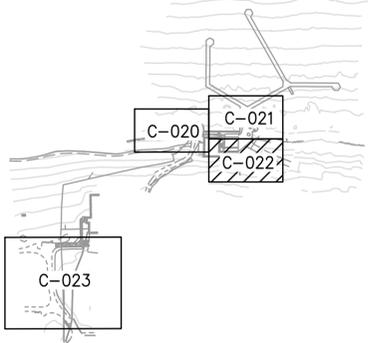

KEY PLAN

CAD USER: dgilbert PLOT DATE: Apr 13, 2023-02:24pm
 PATH: \\kpf\proj\Projects\2020\20000291 Luther Burbank Park\Drawings\Current (DWG2018)\C-020-023 GRADING PLAN (1-4). Updated.dwg



NO.	DATE	BY	REVISION
1A	4/14/2023	ROL	MIFD COMMENT REVISION



LUTHER BURBANK PARK
 WATERFRONT IMPROVEMENTS

GRADING PLAN-3

DRAWN: AS	PROJECT NO.: 2200248
DESIGN: SS	SCALE: 1" = 5'
CHECKED: NAW	DATE: 10/07/2022
DRAWING NO.	C-022
SHEET NO.	14 of 56

60% SUBMITTAL

CAD USER: dgilbert PLOT DATE: Apr 13, 2023-02:24pm
 PATH: \\kpf\proj\Projects\2020\20000291 Luther Burbank Park\Drawings\Current (DWG2018)\C-020-023 GRADING PLAN (1-4). Updated.dwg

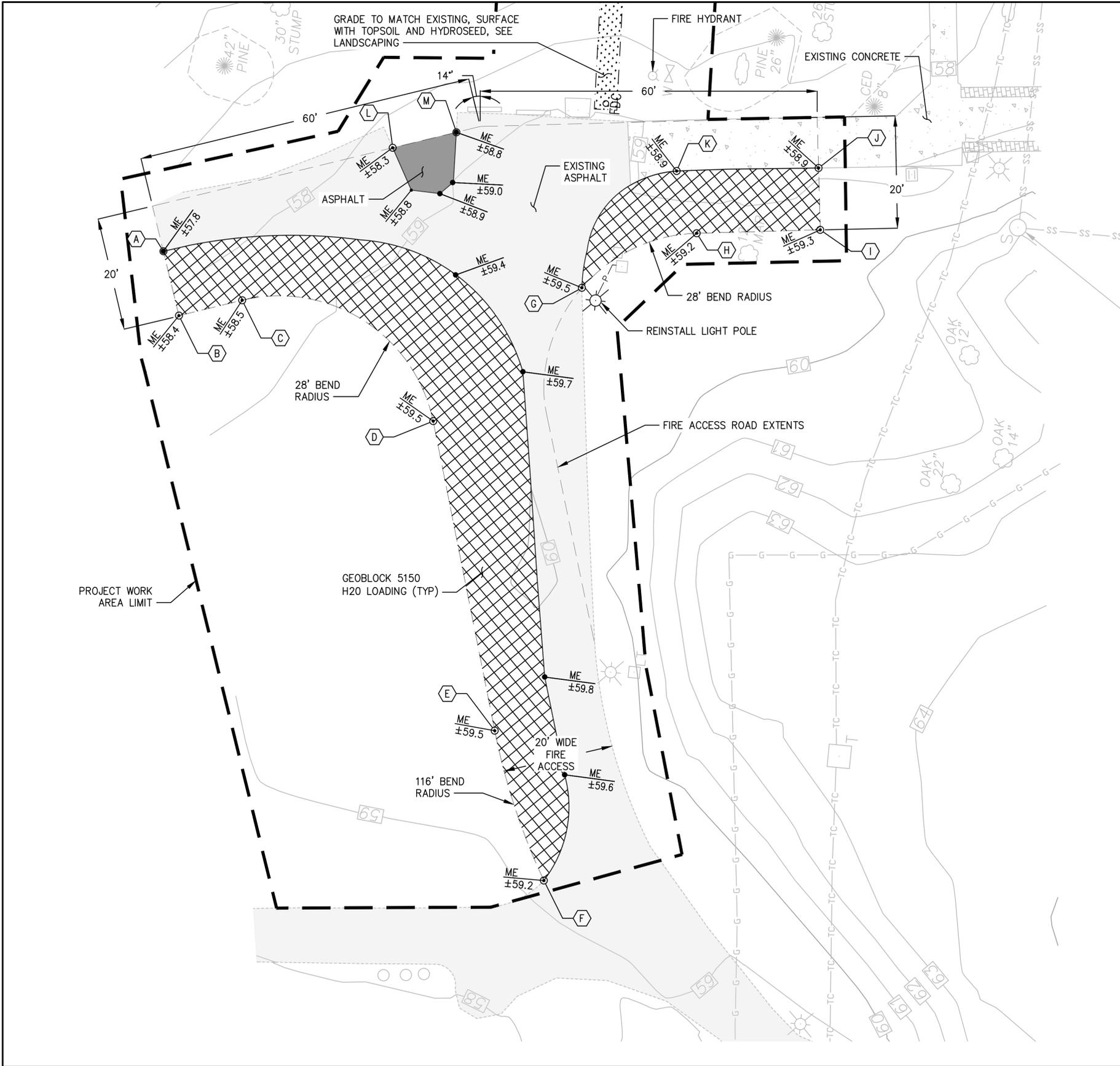

HORIZONTAL CONTROL

POINT #	NORTHING	EASTING	POINT #	NORTHING	EASTING
A			I		
B			J		
C			K		
D			L		
E			M		
F					
G					
H					

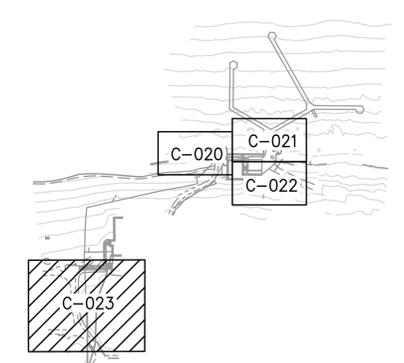

KEY PLAN

LEGEND

- GRADE BREAK
- - - FIRE ACCESS
- PROJECT WORK AREA LIMIT
- [Hatched Box] EXISTING ASPHALT
- [Cross-hatched Box] EXISTING BRICK
- [Dotted Box] EXISTING CONCRETE
- [Diagonal Hatched Box] GEOGRID 5150 H2O LOADING
- [Solid Grey Box] ASPHALT

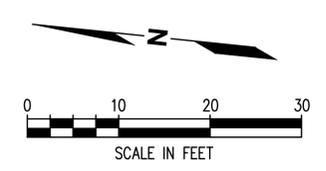

1601 5th Avenue, Suite 1600
 Seattle, WA 98101
 206.622.5822
 www.kpff.com



NO.	DATE	BY	REVISION
1A	4/14/2023	ROL	MIFD COMMENT REVISION



LUTHER BURBANK PARK
 WATERFRONT IMPROVEMENTS

GRADING PLAN-4

DRAWN: AS	PROJECT NO.: 2200248
DESIGN: SS	SCALE: 1" = 10'
CHECKED: NAW	DATE: 10/07/2022
DRAWING NO.	C-023
SHEET NO.	15 of 56

60% SUBMITTAL

CAD USER: dgilbert PLOT DATE: Apr 13, 2023-02:25pm
 PATH: \\kpf\proj\Projects\2020\20000291 Luther Burbank Park\Drawings\Current (DWG2018)\C-030-034 UTILITY PLAN.dwg

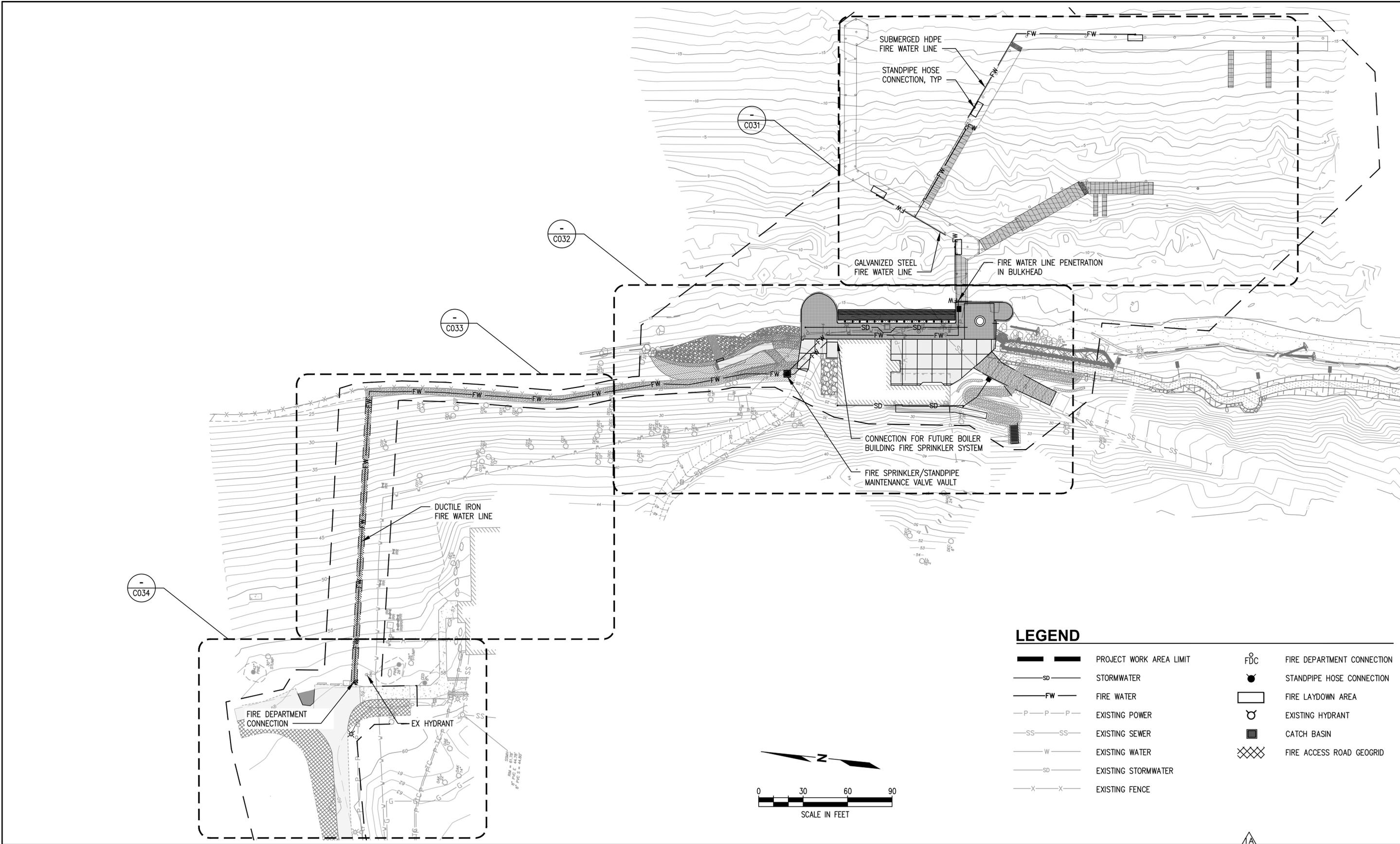

LEGEND

- PROJECT WORK AREA LIMIT
- SD STORMWATER
- FW FIRE WATER
- P EXISTING POWER
- SS EXISTING SEWER
- W EXISTING WATER
- SD EXISTING STORMWATER
- X EXISTING FENCE
- FDC FIRE DEPARTMENT CONNECTION
- STANDPIPE HOSE CONNECTION
- FIRE LAYDOWN AREA
- EXISTING HYDRANT
- CATCH BASIN
- FIRE ACCESS ROAD GEOGRID

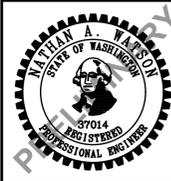
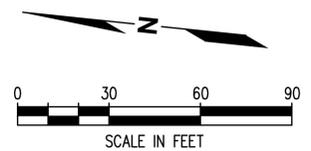

NO.	DATE	BY	REVISION
1A	4/14/2023	ROL	MIFD COMMENT REVISION



LUTHER BURBANK PARK
WATERFRONT IMPROVEMENTS
 UTILITY PLAN - OVERALL

DRAWN: DCG	PROJECT NO.: 2200248
DESIGN: SS	SCALE: AS SHOWN
CHECKED: NAW	DATE: 10/07/2022
DRAWING NO.	C-030
SHEET NO.	17 of 56

60% SUBMITTAL

CAD USER: dgilbert PLOT DATE: Apr 13, 2023-02:25pm
 PATH: \\kpf\proj\Projects\2020\20000291 Luther Burbank Park\Drawings\Current (DWG2018)\C-030-034 UTILITY PLAN.dwg

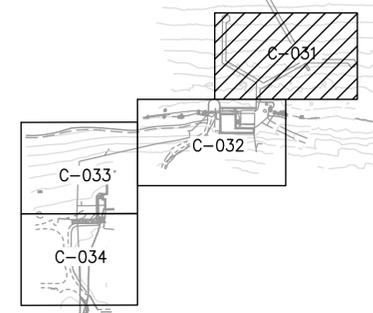
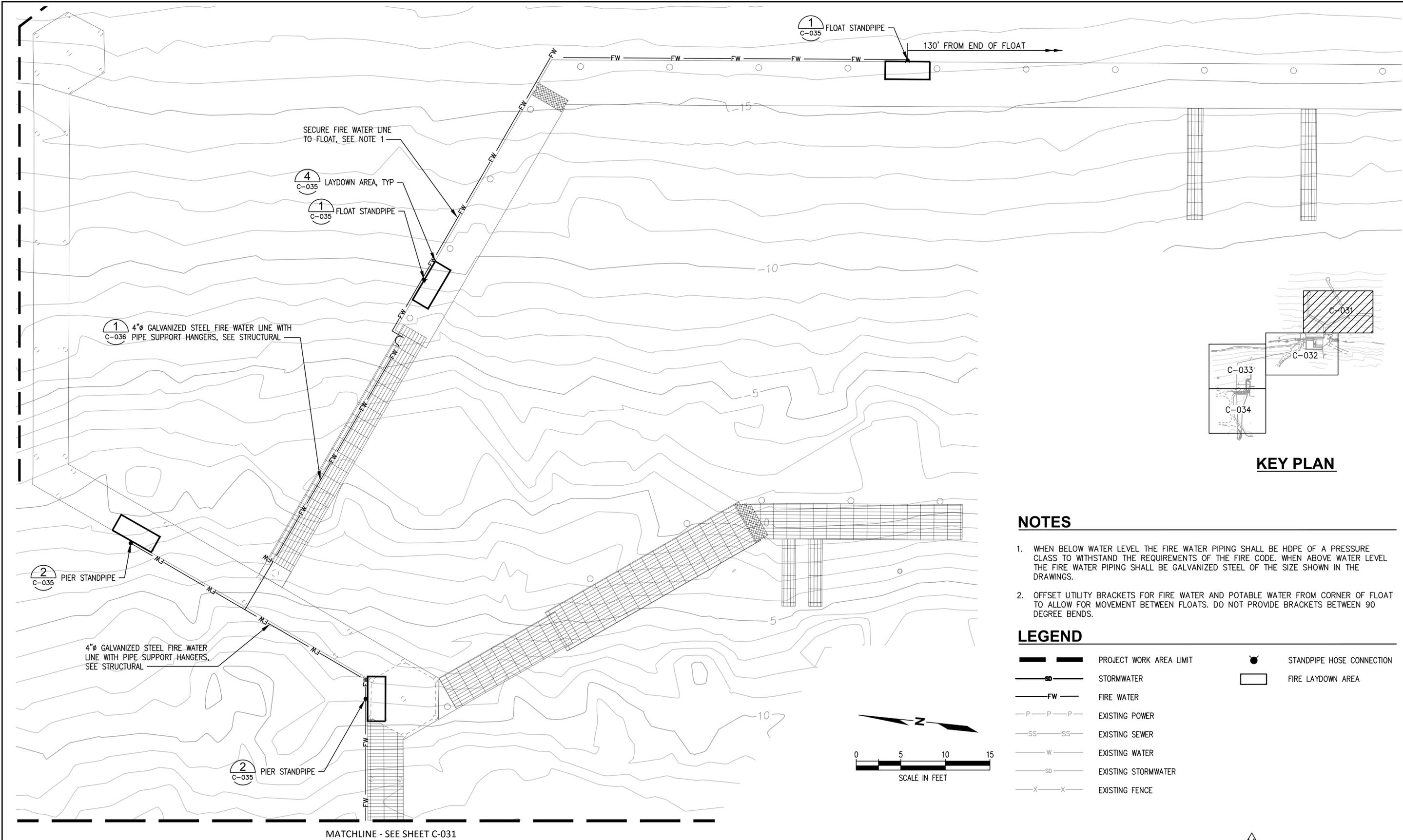

KEY PLAN

NOTES

1. WHEN BELOW WATER LEVEL THE FIRE WATER PIPING SHALL BE HDPE OF A PRESSURE CLASS TO WITHSTAND THE REQUIREMENTS OF THE FIRE CODE. WHEN ABOVE WATER LEVEL THE FIRE WATER PIPING SHALL BE GALVANIZED STEEL OF THE SIZE SHOWN IN THE DRAWINGS.
2. OFFSET UTILITY BRACKETS FOR FIRE WATER AND POTABLE WATER FROM CORNER OF FLOAT TO ALLOW FOR MOVEMENT BETWEEN FLOATS. DO NOT PROVIDE BRACKETS BETWEEN 90 DEGREE BENDS.

LEGEND

- PROJECT WORK AREA LIMIT
- STORMWATER
- FIRE WATER
- EXISTING POWER
- EXISTING SEWER
- EXISTING WATER
- EXISTING STORMWATER
- EXISTING FENCE
- STANDPIPE HOSE CONNECTION
- FIRE LAYDOWN AREA

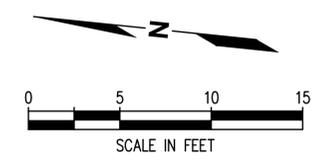

MATCHLINE - SEE SHEET C-031



1601 5th Avenue, Suite 1600
 Seattle, WA 98101
 206.622.5822
 www.kpff.com



NO.	DATE	BY	REVISION
1A	4/14/2023	ROL	MIFD COMMENT REVISION



LUTHER BURBANK PARK
 WATERFRONT IMPROVEMENTS
 UTILITY PLAN - 1

DRAWN: DCG	PROJECT NO.: 2200248
DESIGN: SS	SCALE: AS SHOWN
CHECKED: NAW	DATE: 10/07/2022
DRAWING NO.	C-031
SHEET NO.	18 of 56

60% SUBMITTAL

MATCHLINE - SEE SHEET C-031

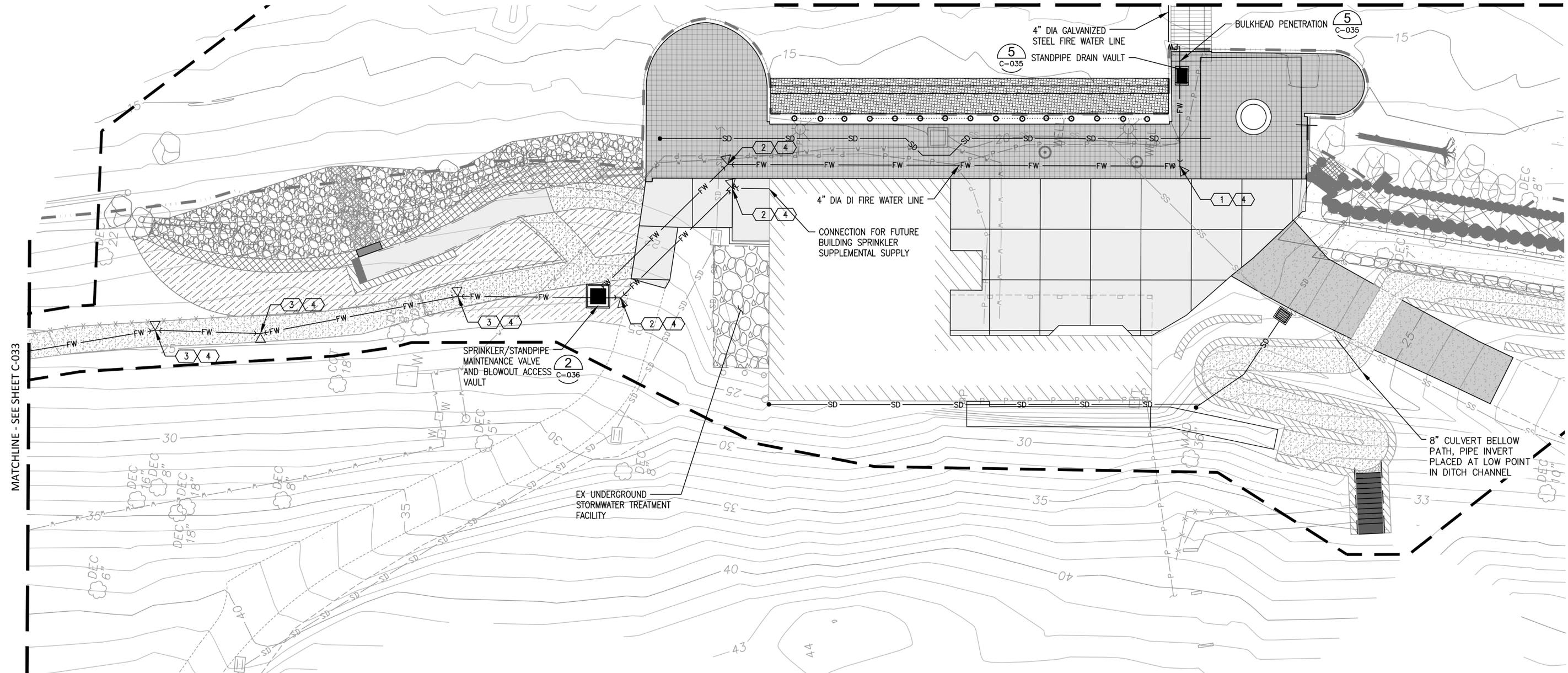

MATCHLINE - SEE SHEET C-033

CONSTRUCTION NOTES

- 1 4"x90" HORIZONTAL BEND
- 2 4"x45" HORIZONTAL BEND
- 3 4"x11.25" HORIZONTAL BEND
- 4 INSTALL THRUST BLOCK

NOTES

1. THE EXISTING UTILITY LOCATIONS AND DEPTHS SHOWN ON THE PLANS ARE APPROXIMATE. NO REPRESENTATION IS MADE AS TO THE ACCURACY OR COMPLETENESS OF THE INFORMATION. THE CONTRACTOR SHALL POTHOLE OR OTHERWISE CONFIRM EXISTING CONDITIONS PRIOR TO START OF WORK. IF CONDITIONS DIFFER FROM THOSE SHOWN ON THE PLANS, THE CONTRACTOR SHALL NOTIFY THE ENGINEER AND SHALL NOT BEGIN CONSTRUCTION UNTIL THE CHANGED CONDITIONS HAVE BEEN EVALUATED. THE CONTRACTOR SHALL TAKE PRECAUTIONARY MEASURES TO PROTECT FROM DAMAGE OR DESTRUCTION ALL UTILITIES AS SHOWN AND ALL UTILITIES NOT SHOWN THAT MAY BE ENCOUNTERED DURING CONSTRUCTION DUE TO NO RECORD OF THEIR EXISTENCE.

LEGEND

- PROJECT WORK AREA LIMIT
- STORMWATER
- FIRE WATER
- EXISTING POWER
- EXISTING SEWER
- EXISTING WATER
- EXISTING STORMWATER
- EXISTING FENCE
- EXISTING HYDRANT
- CATCH BASIN

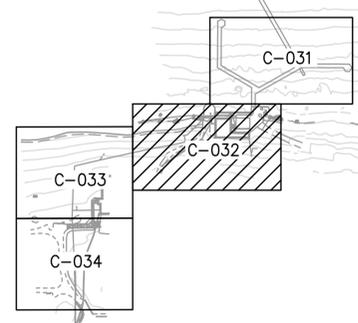
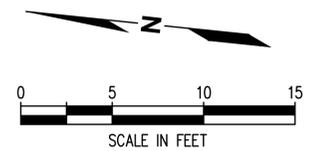

KEY PLAN

CAD USER: dglbert PLOT DATE: Apr 13, 2023-02:25pm
 PATH: \\kpf\proj\Projects\2020\20000291 Luther Burbank Park\Drawings\Current (DWG2018)\C-030-034 UTILITY PLAN.dwg



1601 5th Avenue, Suite 1600
 Seattle, WA 98101
 206.622.5822
 www.kpff.com



NO.	DATE	BY	REVISION
1A	4/14/2023	ROL	MIFD COMMENT REVISION



LUTHER BURBANK PARK
 WATERFRONT IMPROVEMENTS
 UTILITY PLAN - 2

DRAWN: DCG	PROJECT NO.: 2200248
DESIGN: SS	SCALE: AS SHOWN
CHECKED: NAW	DATE: 10/07/2022
DRAWING NO.	C-032
SHEET NO.	19 of 56

60% SUBMITTAL

CAD USER: dglbert PLOT DATE: Apr 13, 2023-02:25pm
 PATH: \\kpf\proj\Projects\2020\20000291 Luther Burbank Park\Drawings\Current (DWG2018)\C-030-034 UTILITY PLAN.dwg

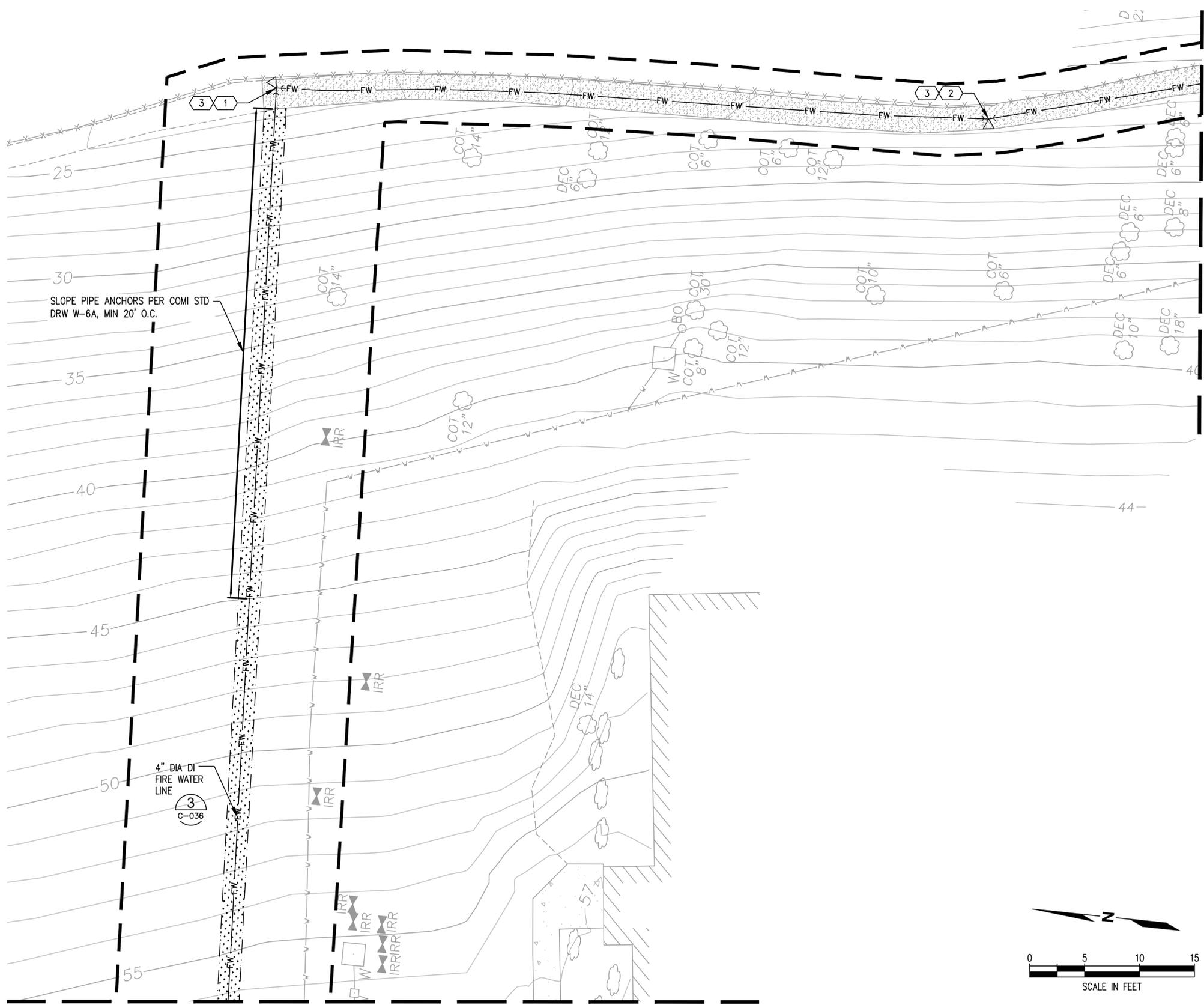

NOTES

1. THE EXISTING UTILITY LOCATIONS AND DEPTHS SHOWN ON THE PLANS ARE APPROXIMATE. NO REPRESENTATION IS MADE AS TO THE ACCURACY OR COMPLETENESS OF THE INFORMATION. THE CONTRACTOR SHALL POTHOLE OR OTHERWISE CONFIRM EXISTING CONDITIONS PRIOR TO START OF WORK. IF CONDITIONS DIFFER FROM THOSE SHOWN ON THE PLANS, THE CONTRACTOR SHALL NOTIFY THE ENGINEER AND SHALL NOT BEGIN CONSTRUCTION UNTIL THE CHANGED CONDITIONS HAVE BEEN EVALUATED. THE CONTRACTOR SHALL TAKE PRECAUTIONARY MEASURES TO PROTECT FROM DAMAGE OR DESTRUCTION ALL UTILITIES AS SHOWN AND ALL UTILITIES NOT SHOWN THAT MAY BE ENCOUNTERED DURING CONSTRUCTION DUE TO NO RECORD OF THEIR EXISTENCE.

CONSTRUCTION NOTES

- ① 4"x90" HORIZONTAL BEND
- ② 4"x11.25" HORIZONTAL BEND
- ③ INSTALL THRUST BLOCK 1
C-037

MATCHLINE - SEE SHEET C-032

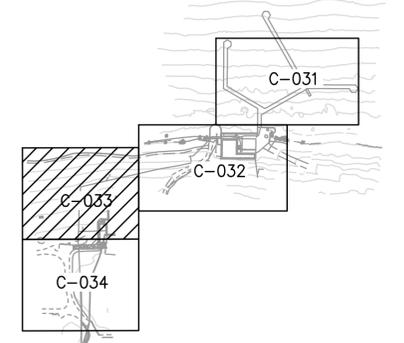

KEY PLAN

LEGEND

- — — — — PROJECT WORK AREA LIMIT
- FDC FIRE DEPARTMENT CONNECTION
- SD — — — — — STORMWATER
- FW — — — — — FIRE WATER
- P — P — P — — — — — EXISTING POWER
- SS — SS — — — — — EXISTING SEWER
- W — — — — — EXISTING WATER
- SD — — — — — EXISTING STORMWATER
- X — X — — — — — EXISTING FENCE
- — — — — STANDPIPE HOSE CONNECTION
- [] FIRE LAYDOWN AREA
- [] EXISTING HYDRANT
- [] CATCH BASIN

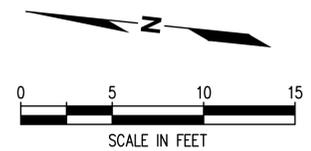

MATCHLINE - SEE SHEET C-034



1601 5th Avenue, Suite 1600
 Seattle, WA 98101
 206.622.5822
 www.kpff.com

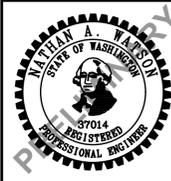

NO.	DATE	BY	REVISION
1A	4/14/2023	ROL	MIFD COMMENT REVISION



LUTHER BURBANK PARK
WATERFRONT IMPROVEMENTS
 UTILITY PLAN - 3

DRAWN: DCG	PROJECT NO.: 2200248
DESIGN: SS	SCALE: AS SHOWN
CHECKED: NAW	DATE: 10/07/2022
DRAWING NO.	C-033
SHEET NO.	20 of 56

60% SUBMITTAL

CAD USER: dgilbert PLOT DATE: Apr 13, 2023-02:25pm
 PATH: \\kpf\proj\Projects\2020\20000291 Luther Burbank Park\Drawings\Current (DWG2018)\C-030-034 UTILITY PLAN.dwg



NO.	DATE	BY	REVISION
1A	4/14/2023	ROL	MIFD COMMENT REVISION



LUTHER BURBANK PARK
WATERFRONT IMPROVEMENTS
 UTILITY PLAN - 4

DRAWN: DCG	PROJECT NO.: 2200248
DESIGN: SS	SCALE: AS SHOWN
CHECKED: NAW	DATE: 10/07/2022
DRAWING NO.	C-034
SHEET NO.	21 OF 56



NOTES

- THE EXISTING UTILITY LOCATIONS AND DEPTHS SHOWN ON THE PLANS ARE APPROXIMATE. NO REPRESENTATION IS MADE AS TO THE ACCURACY OR COMPLETENESS OF THE INFORMATION. THE CONTRACTOR SHALL POthOLE OR OTHERWISE CONFIRM EXISTING CONDITIONS PRIOR TO START OF WORK. IF CONDITIONS DIFFER FROM THOSE SHOWN ON THE PLANS, THE CONTRACTOR SHALL NOTIFY THE ENGINEER AND SHALL NOT BEGIN CONSTRUCTION UNTIL THE CHANGED CONDITIONS HAVE BEEN EVALUATED. THE CONTRACTOR SHALL TAKE PRECAUTIONARY MEASURES TO PROTECT FROM DAMAGE OR DESTRUCTION ALL UTILITIES AS SHOWN AND ALL UTILITIES NOT SHOWN THAT MAY BE ENCOUNTERED DURING CONSTRUCTION DUE TO NO RECORD OF THEIR EXISTENCE.

CONSTRUCTION NOTES

- 1 FDC ASSEMBLY
- 2 REINSTALL LIGHT POLE, FOUNDATION PER STRUCTURAL
- 3 C-035

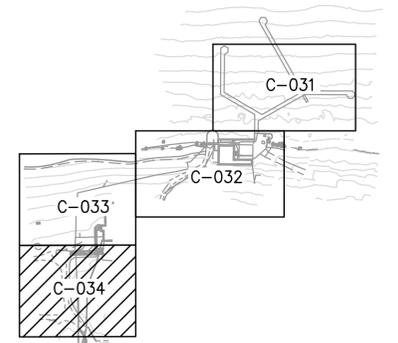

KEY PLAN

LEGEND

- PROJECT WORK AREA LIMIT
- STORMWATER
- FIRE WATER
- EXISTING POWER
- EXISTING SEWER
- EXISTING WATER
- EXISTING STORMWATER
- EXISTING FENCE
- FIRE DEPARTMENT CONNECTION
- STANDPIPE HOSE CONNECTION
- FIRE LAYDOWN AREA
- EXISTING HYDRANT
- CATCH BASIN
- FIRE ACCESS ROAD GEOGRID
- FIRE ACCESS ROAD ASPHALT PAVING
- EXISTING ASPHALT PATH

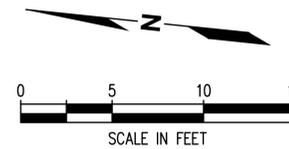

60% SUBMITTAL

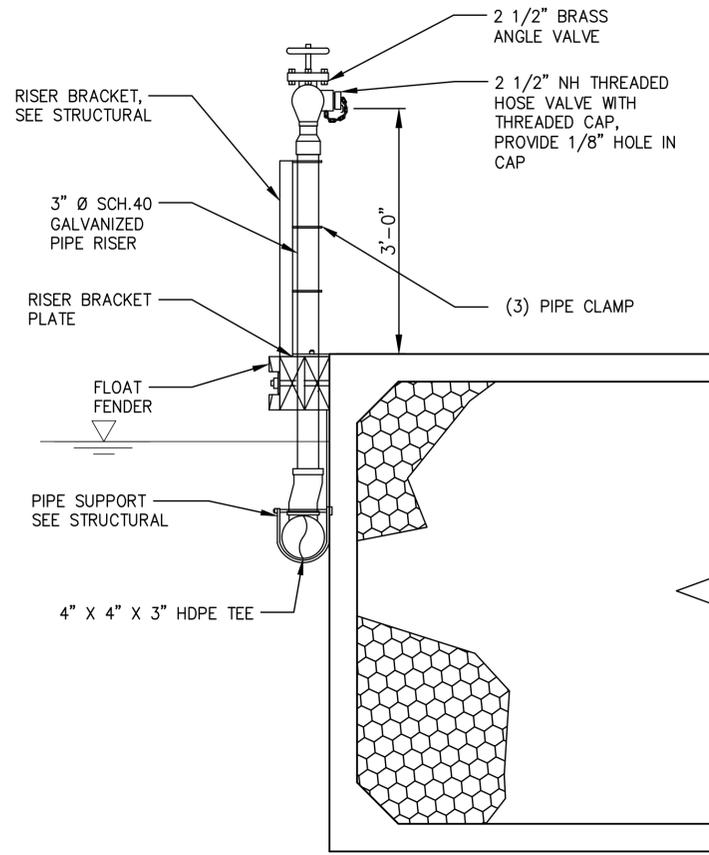

1 STANDPIPE SECTION - CONCRETE FLOAT
C-031 NTS

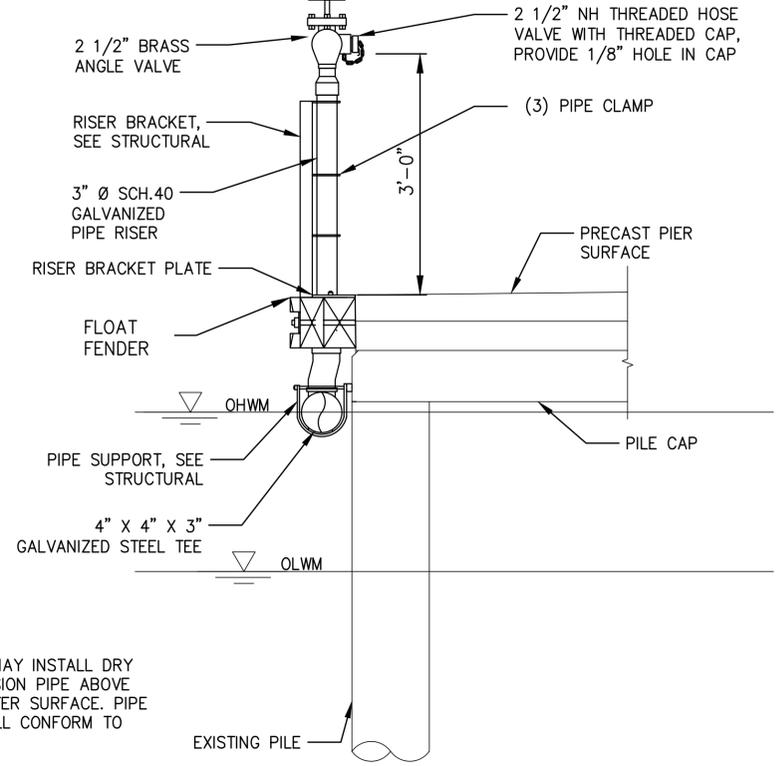

2 STANDPIPE SECTION
C-031 NTS

NOTES
1. CONTRACTOR MAY INSTALL DRY FIRE SUPPRESSION PIPE ABOVE OR BELOW WATER SURFACE. PIPE MATERIAL SHALL CONFORM TO NFPA 14.

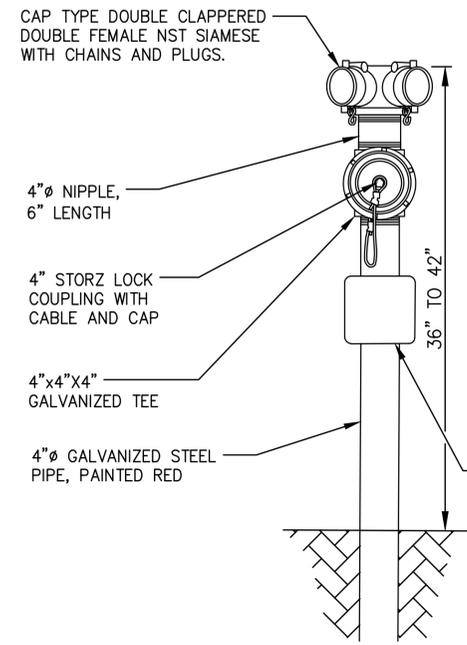

3 FIRE DEPARTMENT CONNECTION
C-034 NTS

FDC SIGN NOTES:
1. ALL MATERIALS SHALL BE NFPA COMPLIANT
2. SIGN AND LETTER COLORS
a. SIGN SHALL BE WHITE LETTERS ON A RED BACKGROUND
3. SIZE AND MATERIAL
a. 2" BLACK LETTERS STENCIL PAINTED ON METAL
4. SIGN TERMINOLOGY
a. "SPRINKLER-STANDPIPE, 200 PSI" WITH JOB ADDRESS
5. ADDRESS NUMERALS SHALL BE ABOVE THE SYSTEM TYPE

ADDRESS
FOR SIGN COLOR, SIZE, MATERIAL, WORDING AND LETTER SIZE SEE NOTES.
SYSTEM TYPE
FDC SIGN

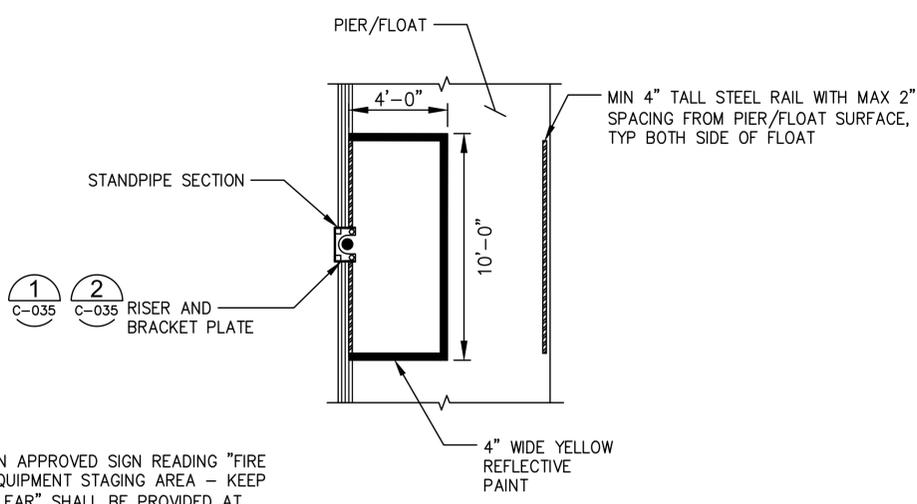

4 FIRE STAGING AREA
C-031 NTS

NOTES
1. AN APPROVED SIGN READING "FIRE EQUIPMENT STAGING AREA - KEEP CLEAR" SHALL BE PROVIDED AT EACH STAGING AREA.

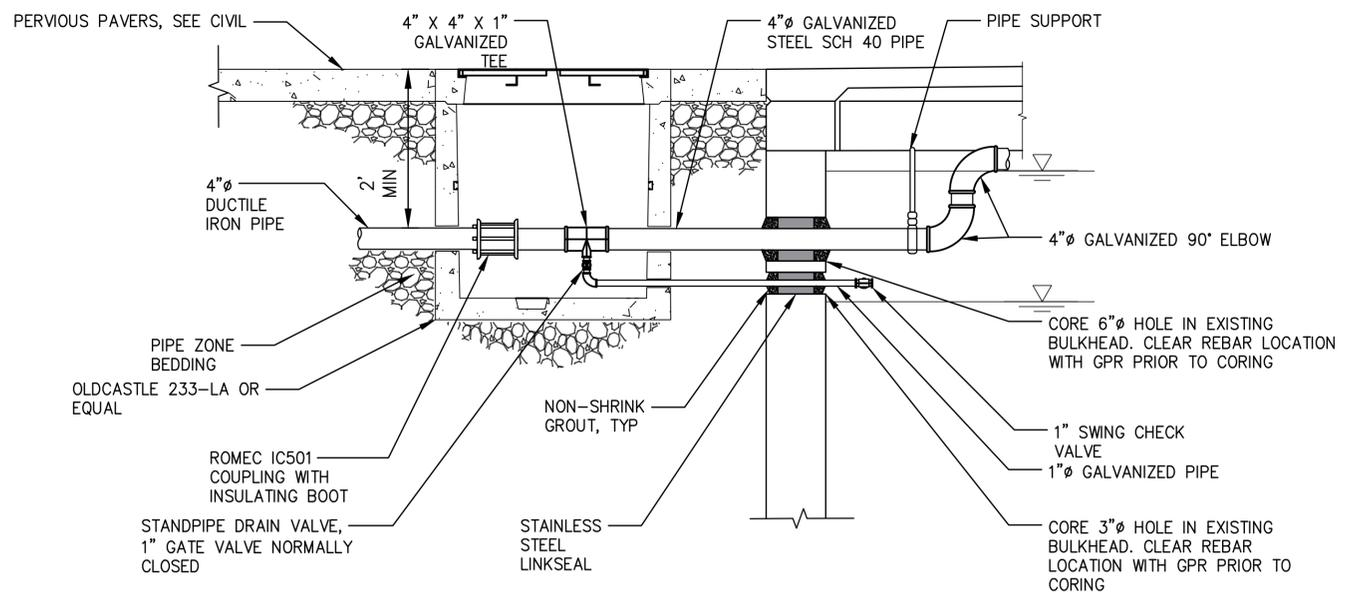

5 BULKHEAD PENETRATION DETAIL
C-032 NTS

CAD USER: dgilbert PLOT DATE: Apr 13, 2023-02: 25pm
PATH: \\kpf\proj\Projects\2020\20000291 Luther Burbank Park\Drawings\Current (DWG2018)\C-035-037 UTILITY DETAILS.dwg



1601 5th Avenue, Suite 1600
Seattle, WA 98101
206.622.5822
www.kpff.com

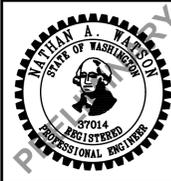

NO.	DATE	BY	REVISION
1A	4/14/2023	ROL	MIFD COMMENT REVISION



LUTHER BURBANK PARK
WATERFRONT IMPROVEMENTS
UTILITY DETAILS - 1

DRAWN: DCG	PROJECT NO.: 2200248
DESIGN: SS	SCALE: AS SHOWN
CHECKED: NAW	DATE: 10/07/2022
DRAWING NO.	C-035
SHEET NO.	22 OF 56

60% SUBMITTAL

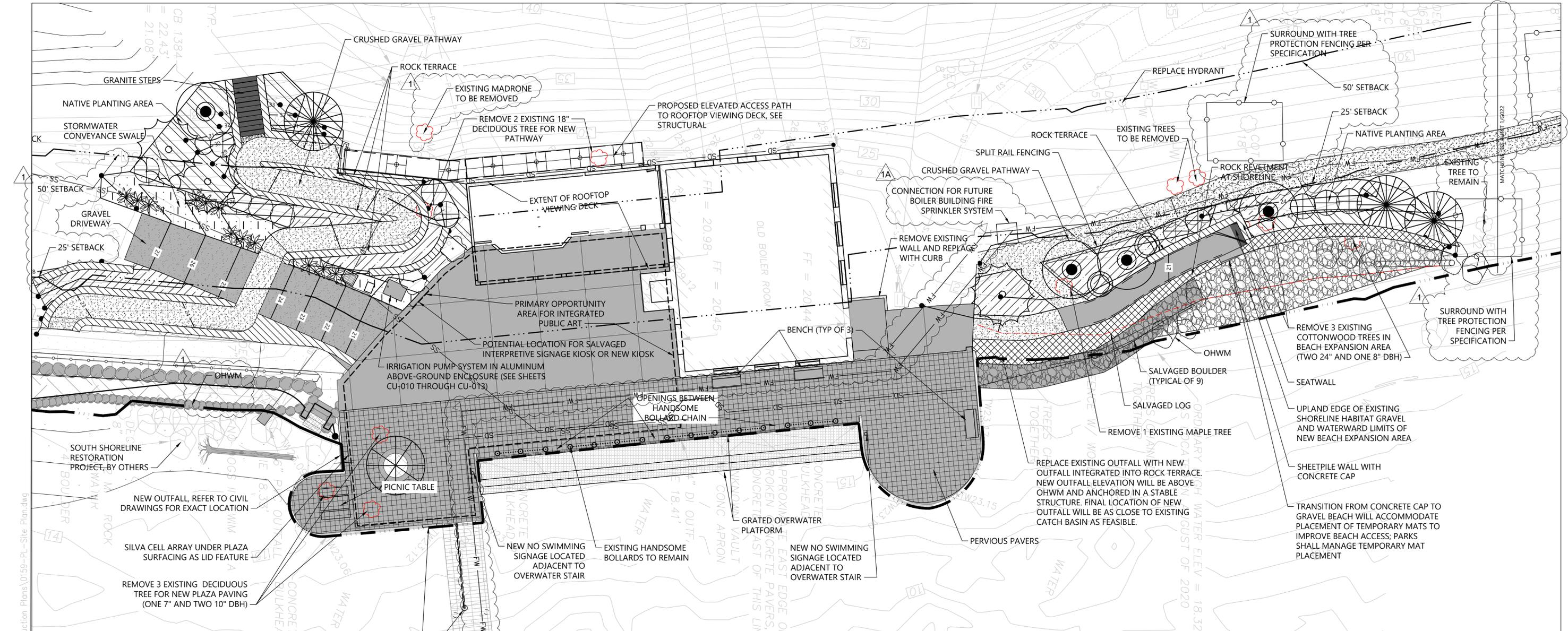

LEGEND:

EXISTING CONTOUR	GRAVEL DRIVEWAY PAVING	SALVAGED LOG
EXISTING TREE TO RETAIN	HABITAT GRAVEL	SALVAGED BOULDER
EXISTING TREE TO REMOVE	ROCK TERRACE	PROPOSED TREE
EXISTING UPLAND EDGE OF SHORELINE HABITAT GRAVEL	ROCK REVETMENT	PROPOSED SHRUBS/GROUNDCOVERS
EXISTING ORDINARY HIGH WATER LINE	FRP GRATING	RIPARIAN SHRUBS
EXISTING BOULDER TO RETAIN	HANDRAIL	NATIVE UPLAND PLANTING/GROUNDCOVER
PROPOSED CONTOUR	SPLIT RAIL FENCING	STORMWATER CONVEYANCE PLANTING
PERVIOUS PAVERS	PICNIC TABLE	
CONCRETE SLAB ON GRADE WITH SAWCUT JOINT SCORING	BENCH	
CRUSHED GRAVEL PATHWAY		

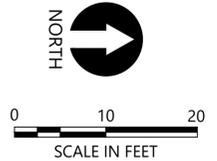

- NOTES:**
- HORIZONTAL DATUM: WASHINGTON STATE PLANE NORTH ZONE, NAD83 (2011), U.S. SURVEY FEET
 - VERTICAL DATUM: NAVD88

CAD USER: randersn PLOT DATE: Apr 13, 2023-01:11pm
 PATH: K:\Projects\0159-KPFF Consulting Engineers\Mercer Island\Burbank Dock Repair\Construction Plans\0159-PL-Site Plan.dwg

1601 5th Avenue, Suite 1600
 Seattle, WA 98101
 206.622.5822
 www.kpff.com

NO.	DATE	BY	REVISION
1	4/14/2023	RA	LAND USE PERMIT REVISION
1A	4/14/2023	RA	MIFD COMMENT REVISION



**LUTHER BURBANK PARK
 WATERFRONT IMPROVEMENTS**

1 1A
COMPOSITE SITE PLAN - 1

DRAWN: CW/RF	PROJECT NO.: 2200248
DESIGN: AS	SCALE: AS NOTED
CHECKED: AS/DR	DATE: 10/07/2022
DRAWING NO.	G-021
SHEET NO. 25	OF 56

60% SUBMITTAL

CAD USER: randersden PLOT DATE: Apr 13, 2023-01:12pm
 PATH: K:\Projects\0159-KPFF Consulting Engineers\Mercer Island Luther Burbank Dock Repair\Construction Plans\0159-PL-Site Plan.dwg



1 UTILITY VIEW 2
 SCALE: 1" = 10'

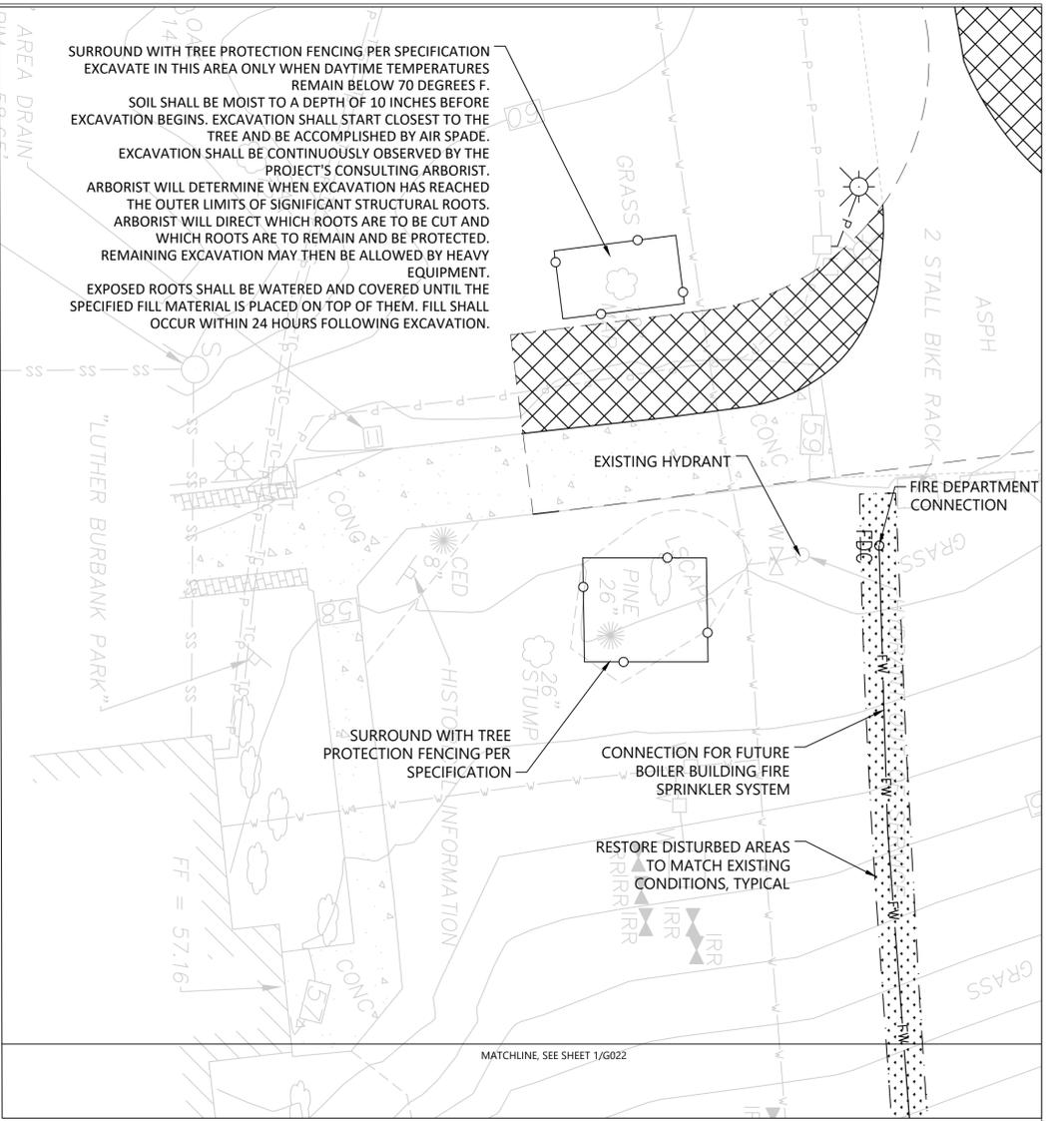

2 UTILITY VIEW 2
 SCALE: 1" = 10'

LEGEND:

- EXISTING CONTOUR
- EXISTING TREE TO RETAIN
- PROPOSED CONTOUR
- CRUSHED GRAVEL PATHWAY
- GEOGRID
- LAWN

NOTES:

- HORIZONTAL DATUM: WASHINGTON STATE PLANE NORTH ZONE, NAD83 (2011), U.S. SURVEY FEET
- VERTICAL DATUM: NAVD88

SCALE IN FEET
 0 10 20

NORTH

kpff
 1601 5th Avenue, Suite 1600
 Seattle, WA 98101
 206.622.5822
 www.kpff.com

ANCHOR QEA

NO.	DATE	BY	REVISION
1	4/14/2023	RA	LAND USE PERMIT REVISION
1A	4/14/2023	RA	MIFD COMMENT REVISION



LUTHER BURBANK PARK WATERFRONT IMPROVEMENTS

COMPOSITE SITE PLAN - 2

DRAWN: CW/RF	PROJECT NO.: 2200248
DESIGN: AS	SCALE: AS NOTED
CHECKED: AS/DR	DATE: 10/07/2022
DRAWING NO.	G-022
SHEET NO. 26	OF 56

60% SUBMITTAL

LEGEND:

- EXISTING CONTOUR
- EXISTING TREE TO RETAIN
- EXISTING ORDINARY HIGH WATER LINE
- EXISTING IRRIGATION LINE
- EXISTING BOULDER TO RETAIN
- PROPOSED CONTOUR
- PERVIOUS PAVERS
- CONCRETE SLAB ON GRADE WITH SAWCUT JOINT SCORING
- CRUSHED GRAVEL PATHWAY
- GRAVEL DRIVEWAY PAVING
- EXISTING BOLLARD AND CHAIN TO REMAIN
- HABITAT GRAVEL
- GRAVEL OVER COBBLE
- ROCK TERRACE
- ROCK REVETMENT
- FRP GRATING
- HANDRAIL
- SPLIT RAIL FENCING
- PICNIC TABLE
- BENCH
- SALVAGED LOG
- SALVAGED BOULDER
- PROPOSED PIPE (BURIED)
- PROPOSED PIPE (ABOVE GROUND)
- PROPOSED INTAKE SCREEN
- PROPOSED PUMP SYSTEM

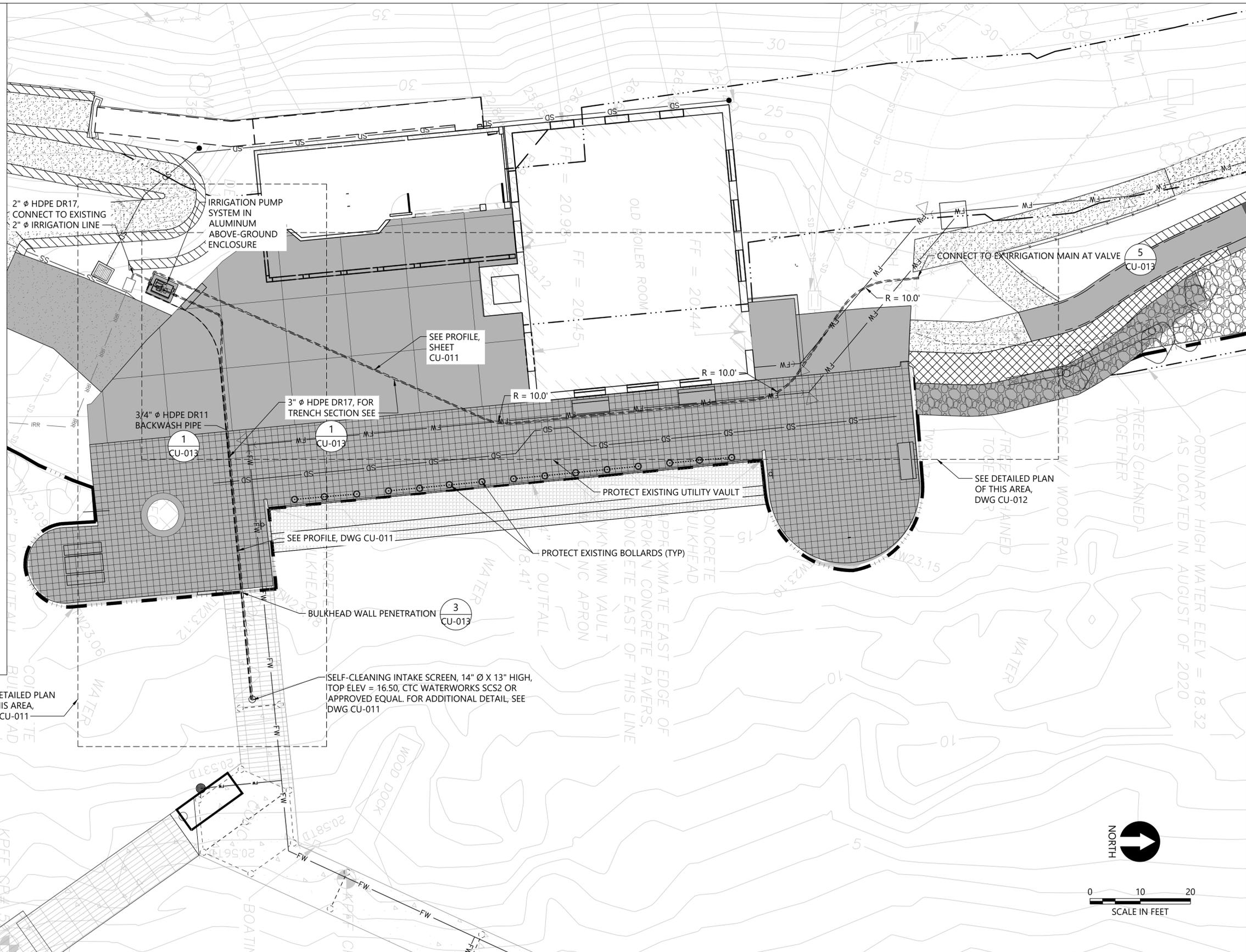

NOTES:

1. HORIZONTAL DATUM: WASHINGTON STATE PLANE NORTH ZONE, NORTH AMERICAN DATUM OF 1983 (NAD83), U.S. SURVEY FEET
2. VERTICAL DATUM: NORTH AMERICAN VERTICAL DATUM OF 1988 (NAVD88).
3. SURVEY BASE MAP FROM PACIFIC GEOMATIC SERVICES, DATED OCTOBER 28, 2019.



1601 5th Avenue, Suite 1600
Seattle, WA 98101
206.622.5822
www.kpff.com

NO.	DATE	BY	REVISION
1A	4/14/2023	RA	MIFD COMMENT REVISION



LUTHER BURBANK PARK
WATERFRONT IMPROVEMENTS

INTAKE AND PUMPING FACILITIES -
OVERALL PLAN

DRAWN: CW/RF	PROJECT NO.: 2200248
DESIGN: AS	SCALE: AS NOTED
CHECKED: AS/DR	DATE: 10/07/2022
DRAWING NO. CU-010	
SHEET NO. 27 OF 56	

60% SUBMITTAL

CAD USER: randersens PLOT DATE: Apr 13, 2023-01:12pm
PATH: K:\Projects\0159-KPFF Consulting Engineers\Mercer Island Luther Burbank Dock Repair\Construction Plans\0159-PL-Intake-Overall-Site-Plan.dwg

NOTES:

- HORIZONTAL DATUM: WASHINGTON STATE PLANE NORTH ZONE, NORTH AMERICAN DATUM OF 1983 (NAD83), U.S. SURVEY FEET
- VERTICAL DATUM: NORTH AMERICAN VERTICAL DATUM OF 1988 (NAVD88).
- SURVEY BASE MAP FROM PACIFIC GEOMATIC SERVICES, DATED OCTOBER 28, 2019.
- SEE DWG CU-010 FOR SITE MATERIALS LEGEND.
- SEE DWG CU-013 FOR TYPICAL TRENCH SECTION.

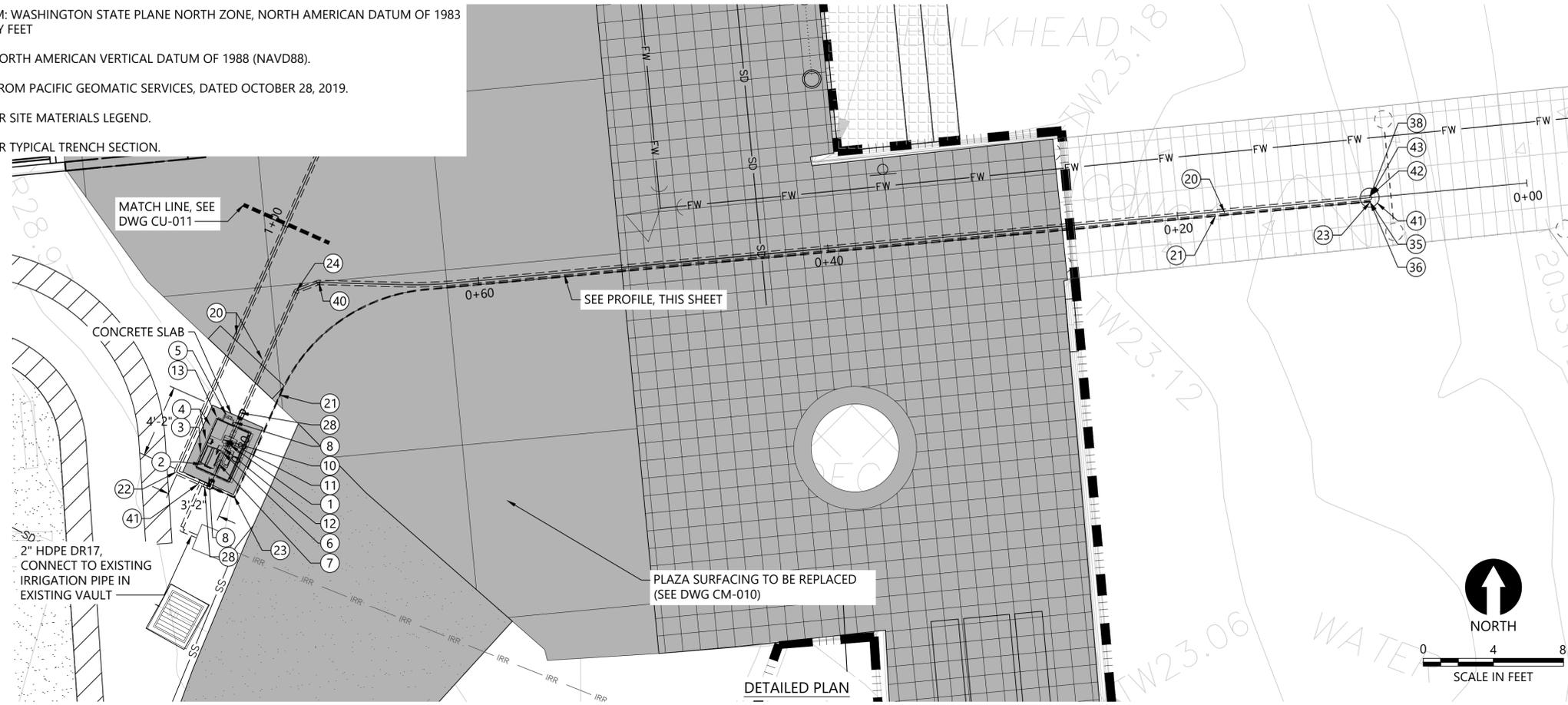

EQUIPMENT LEGEND	
PACKAGED PUMP SYSTEM (RAINBIRD CLP5VAAS OR APPROVED EQUAL):	
NUMBER	DESCRIPTION
1	2" SELF-PRIMING, END-SUCTION, CENTRIFUGAL PUMP W/ VFD, 50 GPM @ 150 FEET TDH, ~ 5 HP*
2	IRRIGATION SYSTEM CONTROLLER
3	MOUNTING BRACKET FOR IRRIGATION SYSTEM CONTROLLER
4	208V 1-PHASE POWER DISCONNECT, PUMP START RELAY
5	MANUAL SWITCH (PROGRAMMABLE CONTROLLER OVERRIDE)
6	LIQUID-FILLED PRESSURE GAUGE, SST, DISCHARGE
7	2" ISOLATION VALVE
8	2-1/2" THREADED PIPE NIPPLE, SST, MNPT
9	2" THREADED NIPPLE, SST, MNPT
10	2" THREADED TEE, SST, FNPT
11	2" THREADED PLUG, SST, MNPT
12	2" THREADED NIPPLE, SST, MNPT, WITH WELDED OUTLET FOR PRESSURE GAGE AND AIR RELEASE VALVE
13	MARINE GRADE ALUMINUM DECK AND ENCLOSURE
SUCTION AND DISCHARGE PIPE AND FITTINGS:	
NUMBER	DESCRIPTION
20	3" HDPE PIPE, DR 17, BUTT-FUSED
21	3/4" HDPE PIPE, DR 11, BUTT-FUSED (BACKWASH LINE)
22	3" HDPE 90° BEND, DR 17, BUTT-FUSED
23	3/4" HDPE 90° BEND, DR11, BUTT-FUSED
24	3" HDPE 45° BEND, DR 17, BUTT-FUSED
25	3" HDPE FLANGE ADAPTER W/ DI BACKING RING
26	3" COMPANION FLANGE, SST, FNPT X FL
27	3" THREADED NIPPLE, SST, MNPT
28	3" 90° BEND, SST, FNPT
29	3" X 2-1/2" HEX BUSHING, SST, MNPT X FNPT
30	3" X 2" HEX BUSHING, SST, MNPT X FNPT
31	3" X 1" TEE, SST, FNPT
32	1" THREADED NIPPLE, SST, MNPT
33	1" 90° BEND, SST, FNPT
34	1" X 3/4" COUPLING, SST, MNPT X PACK JOINT
35	3/4" COUPLING, SST, MNPT X PACK JOINT
36	3/4" UNION, FNPT X FNPT
37	3" HDPE DR 17 TE, BUTT FUSED
38	3" 90° BEND, SST, FL X FL
39	3" HDPE DR 11, FULL PORT, BALL VALVE, BUTT FUSED, WITH 2" OPERATING NUT
40	3" HDPE 22.5° BEND, DR17, BUTT-FUSED
41	3" HDPE 22.5° BEND, DR17, BUTT-FUSED
FISH SCREEN AND ASSOCIATED FITTINGS:	
NUMBER	DESCRIPTION
42	CTC WATERWORKS SCS2, 100 GPM MAX, SELF-CLEANING INTAKE SCREEN, OR APPROVED EQUAL
43	3" COMPANION FL, SST
44	3" DOUBLE DOOR CHECK VALVE, WAFER STYLE

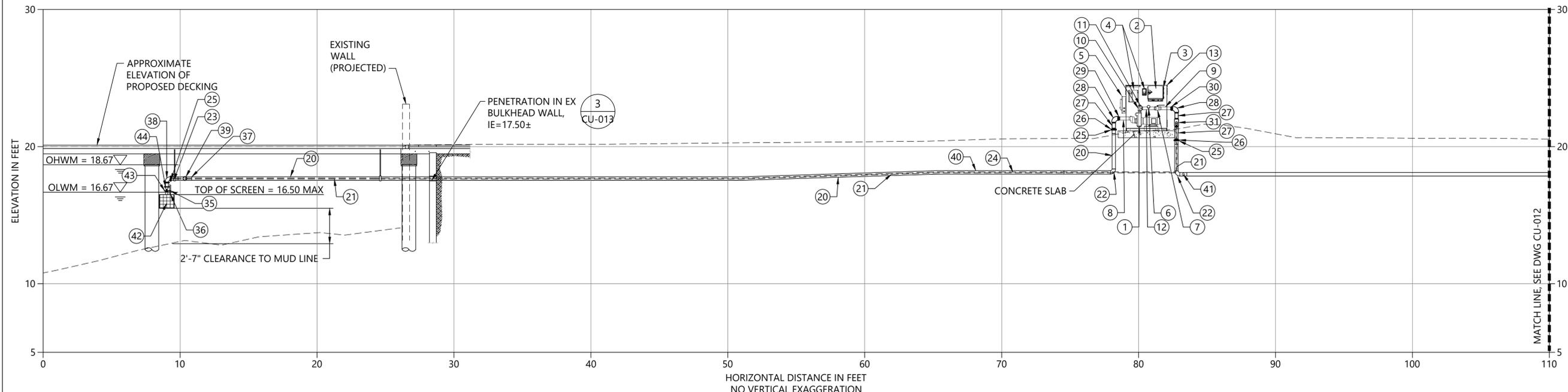

A PIPE PROFILE
SCALE: 1" = 4'

CAD USER: randersens PLOT DATE: Apr 13, 2023-01:12pm
PATH: K:\Projects\0159-KPFF Consulting Engineers\Mercer Island Luther Burbank Park\Intake-Overall-Site-Plan.dwg

NO.	DATE	BY	REVISION
1A	4/14/2023	RA	MIFD COMMENT REVISION



LUTHER BURBANK PARK
WATERFRONT IMPROVEMENTS

INTAKE AND PUMPING FACILITIES -
EQUIPMENT PLAN AND SECTIONS (1 OF 2)

DRAWN: CW/RF	PROJECT NO.: 2200248
DESIGN: AS	SCALE: AS NOTED
CHECKED: AS/DR	DATE: 10/07/2022
DRAWING NO. CU-011	
SHEET NO. 28 OF 56	

60% SUBMITTAL

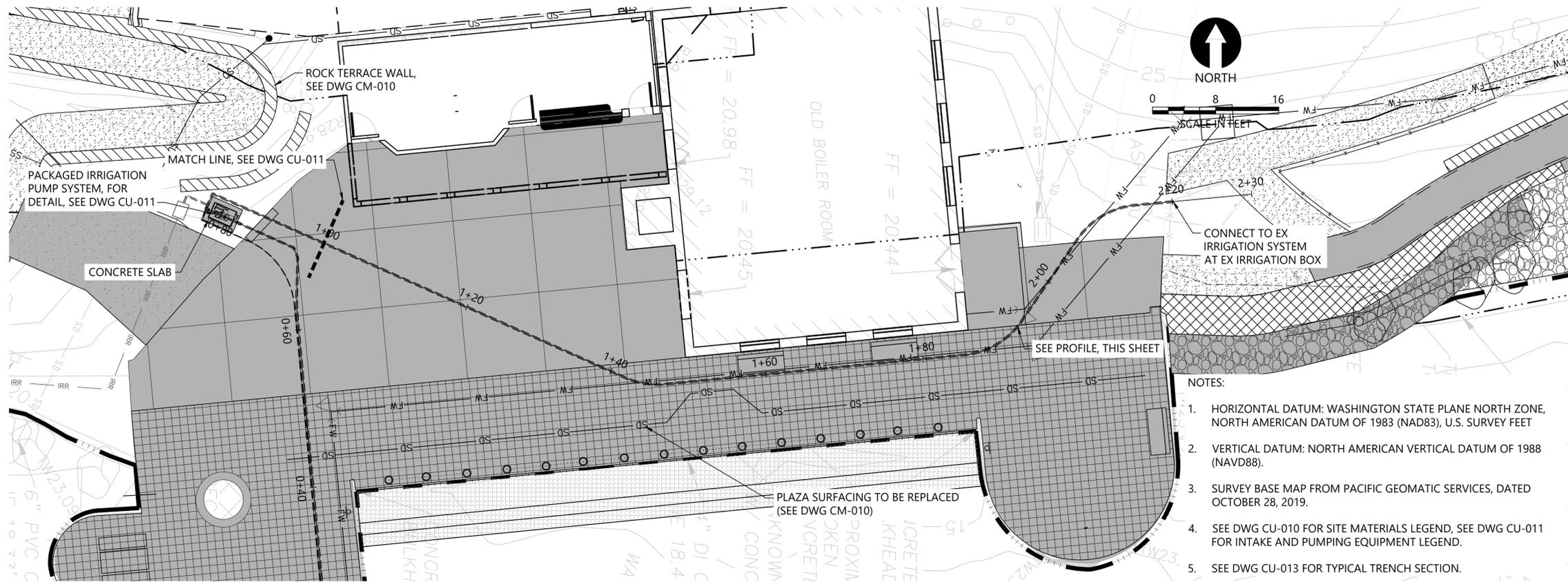

- NOTES:
1. HORIZONTAL DATUM: WASHINGTON STATE PLANE NORTH ZONE, NORTH AMERICAN DATUM OF 1983 (NAD83), U.S. SURVEY FEET
 2. VERTICAL DATUM: NORTH AMERICAN VERTICAL DATUM OF 1988 (NAVD88).
 3. SURVEY BASE MAP FROM PACIFIC GEOMATIC SERVICES, DATED OCTOBER 28, 2019.
 4. SEE DWG CU-010 FOR SITE MATERIALS LEGEND, SEE DWG CU-011 FOR INTAKE AND PUMPING EQUIPMENT LEGEND.
 5. SEE DWG CU-013 FOR TYPICAL TRENCH SECTION.

DETAILED PLAN

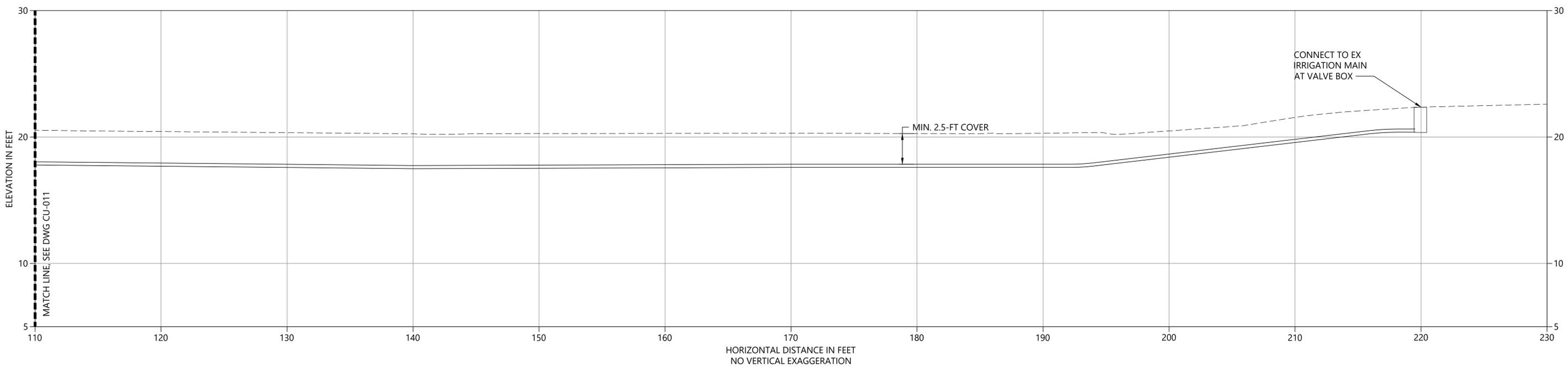

A PIPE PROFILE
SCALE: 1" = 4'

CAD USER: randersens PLOT DATE: Apr 13, 2023-01:12pm
PATH: K:\Projects\0159-KPFF Consulting Engineers\Mercer Island Luther Burbank Dock Repair\Construction Plans\0159-PL-Intake-Overall-Site-Plan.dwg



NO.	DATE	BY	REVISION
1A	4/14/2023	RA	MIFD COMMENT REVISION



LUTHER BURBANK PARK
WATERFRONT IMPROVEMENTS

INTAKE AND PUMPING FACILITIES -
EQUIPMENT PLAN AND SECTIONS (2 OF 2)

DRAWN: CW/RF	PROJECT NO.: 2200248
DESIGN: AS	SCALE: AS NOTED
CHECKED: AS/DR	DATE: 10/07/2022
DRAWING NO. CU-012	
SHEET NO. 29	OF 56

60% SUBMITTAL

CAD USER: randersens PLOT DATE: Apr 13, 2023-01:12pm
 PATH: K:\Projects\0159-KPFF Consulting Engineers\Mercer Island Luther Burbank Dock Repair\Construction Plans\0159-PL-Intake-Overall-Site-Plan.dwg

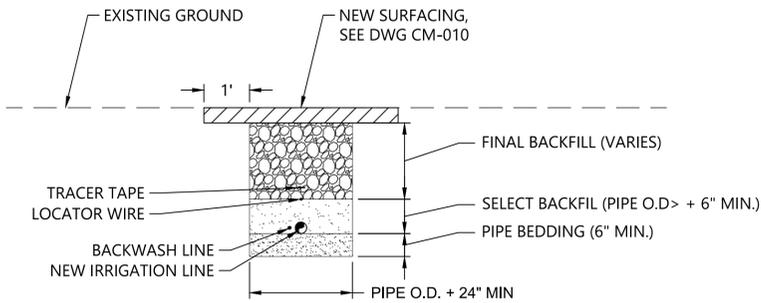

1 TYPICAL TRENCH SECTION
 ### SCALE: NTS

- TYPICAL TRENCH SECTION NOTES:**
1. PIPE BEDDING - PIPE BEDDING SHALL BE AT LEAST 6 INCHES DEEP AND SHALL MEET THE REQUIREMENTS OF SECTION 9-03.12(3) OF THE STANDARD SPECIFICATIONS. IF EXCAVATED TRENCH BOTTOM IS UNSTABLE OR NOT SUITABLE, THE CONTRACTOR SHALL EXCAVATE TO A DEPTH REQUIRED BY THE ENGINEER AND BACKFILL WITH PIPE BEDDING. PLACE PIPE BEDDING IN MAXIMUM 6-INCH LIFTS AND COMPACT TO 90% OF MAXIMUM DRY DENSITY.
 2. SELECT BACKFILL - SELECT FILL SHALL ALSO MEET THE REQUIREMENTS OF SECTION 9-03.12(3) OF THE STANDARD SPECIFICATIONS. PLACE SELECT BACKFILL IN 6-INCH LIFTS TO A MINIMUM DEPTH OF 6 INCHES ABOVE THE CROWN OF THE PIPE AND COMPACT TO 90% OF MAXIMUM DRY DENSITY.
 3. FINAL BACKFILL - UNDER PATHWAYS AND OTHER HARD SURFACES, THE CONTRACTOR SHALL BACKFILL THE REMAINING PORTION OF THE TRENCH TO THE LINES AND GRADES SHOW WITH 5/8-INCH MINUS CRUSHED ROCK SURFACING COMPACTED TO 95% OF MAXIMUM DRY DENSITY.
 4. TRACER TAPE AND LOCATOR WIRE - TRACER TAPE SHALL MEET THE REQUIREMENTS OF SECTION 9-15.18 OF THE STANDARD SPECIFICATIONS. LOCATOR WIRE SHALL BE 12 GA. COPPER MULTI-STRAND RHW, CERTIFIED FOR DIRECT BURIAL. THE TRACER TAPE AND LOCATOR WIRE SHALL BE INSTALLED ALONG THE ENTIRE PROFILE OF THE PIPE.
 5. DRAIN ROCK - WHERE THE PIPE IS INSTALLED ACROSS OR UNDER DRAIN ROCK PLACED AS PART OF AN INFILTRATION TRENCH ADJACENT TO THE BOILER BUILDING, THE CONTRACTOR SHALL BACKFILL THE TRENCH WITH DRAIN ROCK AND OTHER MATERIALS TO MATCH THE MATERIALS EXCAVATED TO PLACE THE IRRIGATION PIPE.

PLACEHOLDER - DETAIL TO BE ADDED AT 90% DESIGN

2 INTAKE SCREEN DETAIL
 ### SCALE: NTS

PLACEHOLDER - DETAIL TO BE ADDED AT 90% DESIGN

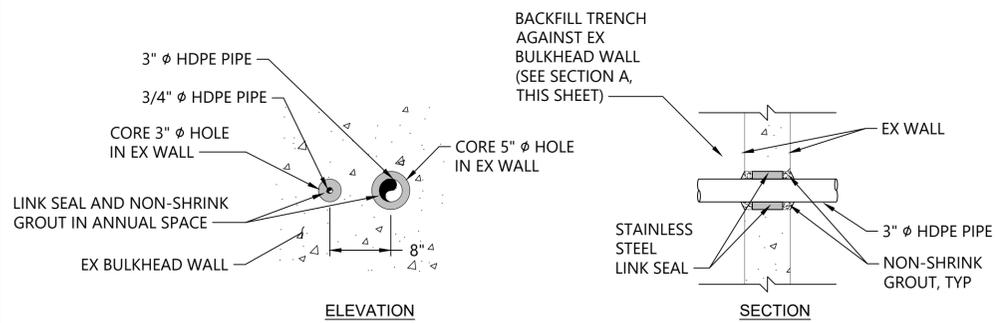

3 BULKHEAD WALL PENETRATION DETAIL
 ### SCALE: 1" = 1'

4 DRAIN VALVE DETAIL
 ### SCALE: NTS

PLACEHOLDER - DETAIL TO BE ADDED AT 90% DESIGN

5 EXISTING IRRIGATION MAIN CONNECTION DETAIL
 ### SCALE: NTS



1601 5th Avenue, Suite 1600
 Seattle, WA 98101
 206.622.5822
 www.kpff.com

NO.	DATE	BY	REVISION
1A	4/14/2023	RA	MIFD COMMENT REVISION



LUTHER BURBANK PARK
 WATERFRONT IMPROVEMENTS

INTAKE AND PUMPING FACILITIES -
 DETAILS

DRAWN: CW/RF	PROJECT NO.: 2200248
DESIGN: AS	SCALE: AS NOTED
CHECKED: AS/DR	DATE: 10/07/2022
DRAWING NO. CU-013	
SHEET NO. 30	OF 56

60% SUBMITTAL

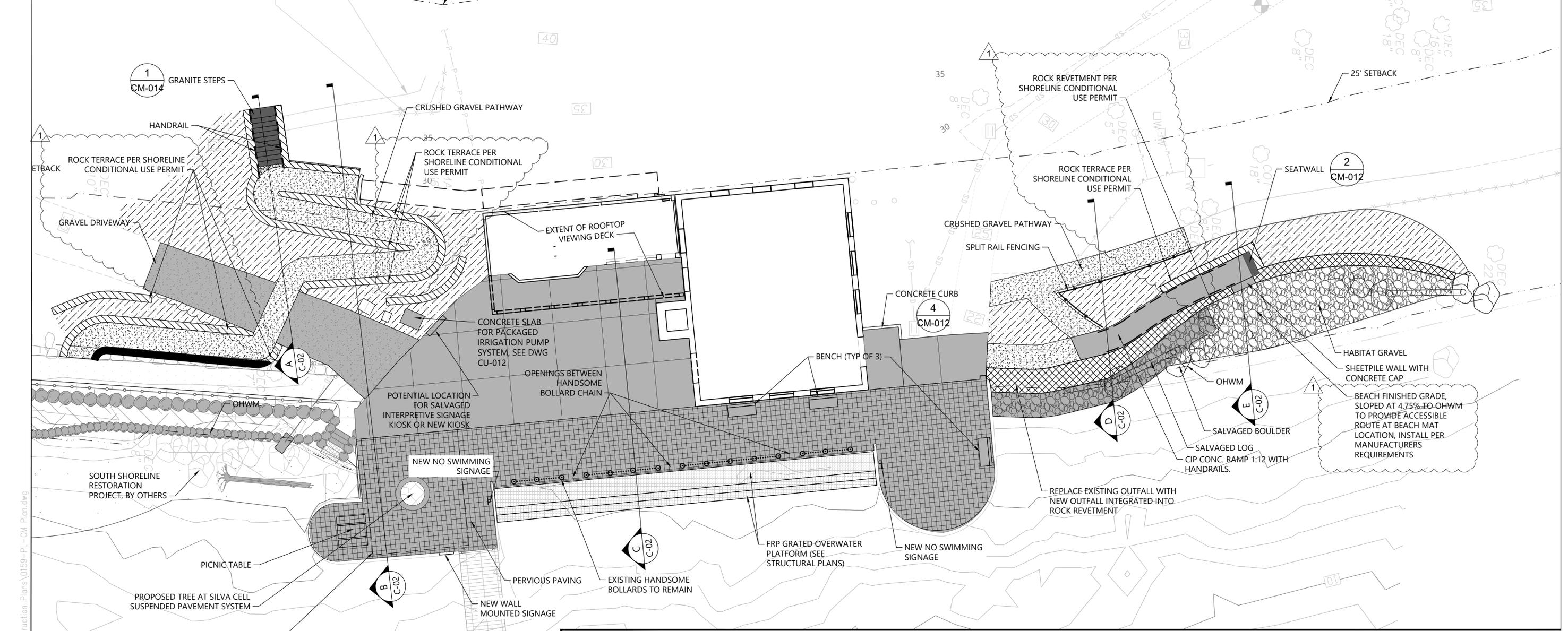

LEGEND:

EXISTING CONTOUR	TOPSOIL
EXISTING TREE TO RETAIN	ROCK TERRACE ⁶ CM-013
EXISTING BOULDER TO RETAIN	ROCK REVETMENT ³ CM-014
PERVIOUS PAVERS	FRP GRATING
CONCRETE SLAB ON GRADE WITH SAWCUT JOINT SCORING ¹ CM-012	HANDRAIL ² CM-014
CRUSHED GRAVEL PATHWAY ² CM-013	SPLIT RAIL FENCING ¹ CM-015
GRAVEL DRIVEWAY PAVING ¹ CM-013	PICNIC TABLE ² CM-015
EXISTING BOLLARD AND CHAIN TO REMAIN	BENCH ³ CM-015
HABITAT GRAVEL ⁴ CM-013	SALVAGED LOG ³ CM-013
GRAVEL OVER COBBLE ⁴ CM-013	SALVAGED BOULDER ⁵ CM-013
	OHWM
	OHWM 25 FT OFFSET

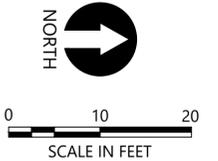

- NOTES:**
- HORIZONTAL DATUM: WASHINGTON STATE PLANE NORTH ZONE, NAD83 (2011), U.S. SURVEY FEET
 - VERTICAL DATUM: NAVD88

CAD USER: randersn PLOT DATE: Apr 13, 2023-01:13pm
 PATH: K:\Projects\0159-KPFF Consulting Engineers\Mercer Island\Construction Plans\0159-PL-CM-Plan.dwg

1601 5th Avenue, Suite 1600
 Seattle, WA 98101
 206.622.5822
 www.kpff.com

NO.	DATE	BY	REVISION
1	4/14/2023	RA	LAND USE PERMIT REVISION
1A	4/14/2023	RA	MIFD COMMENT REVISION



**LUTHER BURBANK PARK
 WATERFRONT IMPROVEMENTS**

MATERIALS PLAN

DRAWN: CW/RF	PROJECT NO.: 2200248
DESIGN: AS	SCALE: AS NOTED
CHECKED: AS/DR	DATE: 10/07/2022
DRAWING NO. CM-010	
SHEET NO. 31	OF 56

60% SUBMITTAL

CAD USER: randersden_PLOT DATE: Apr 13, 2023-01:13pm
 PATH: K:\Projects\0159-KPFF Consulting Engineers\Mercer Island Luther Burbank Dock Repair\Construction Plans\0159-PL-Grading_Plan.dwg

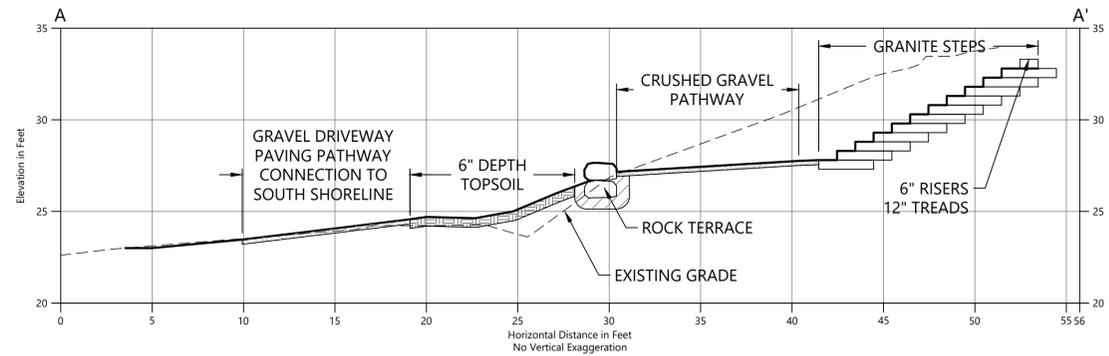

A SECTION A
SCALE: 1" = 5'

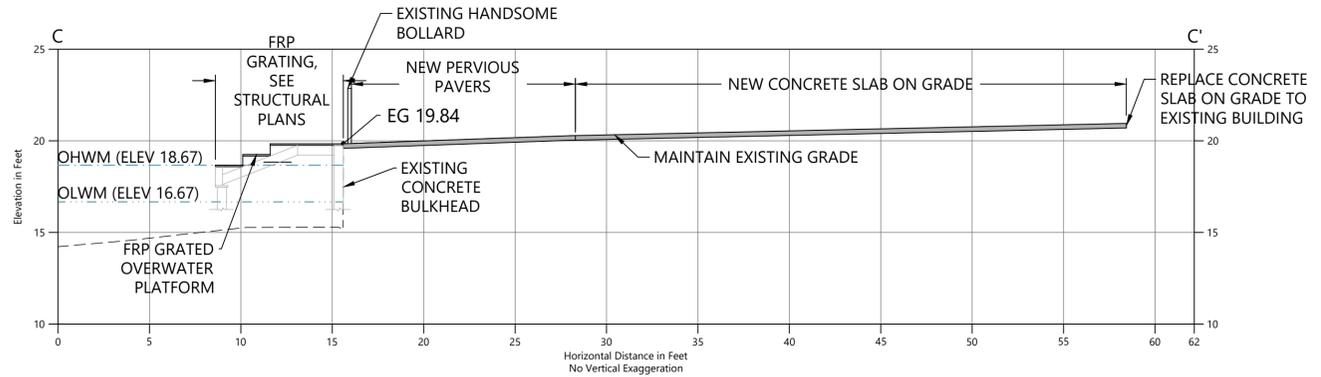

C SECTION C
SCALE: 1" = 5'

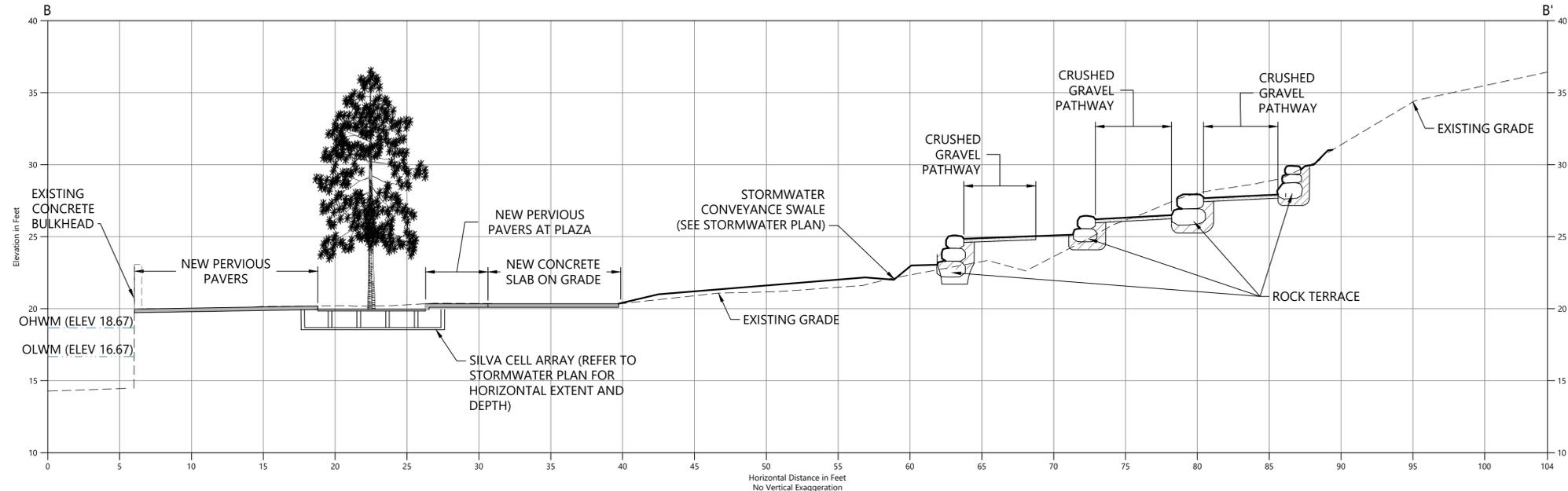

B SECTION B
SCALE: 1" = 5'

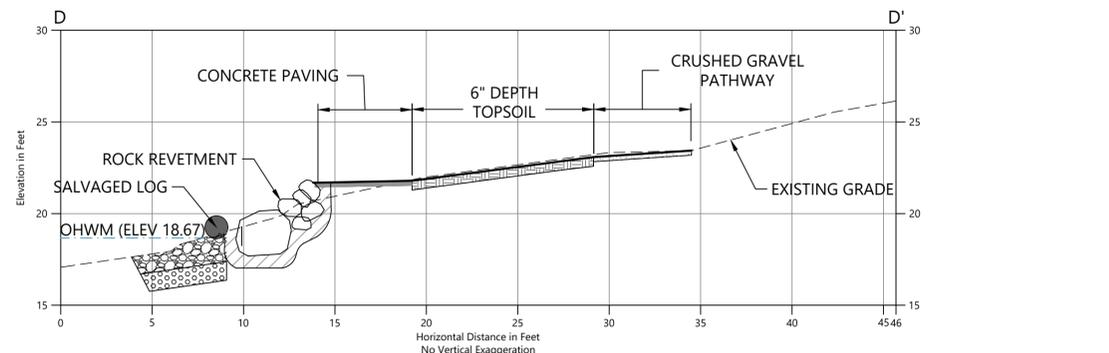

D SECTION D
SCALE: 1" = 5'

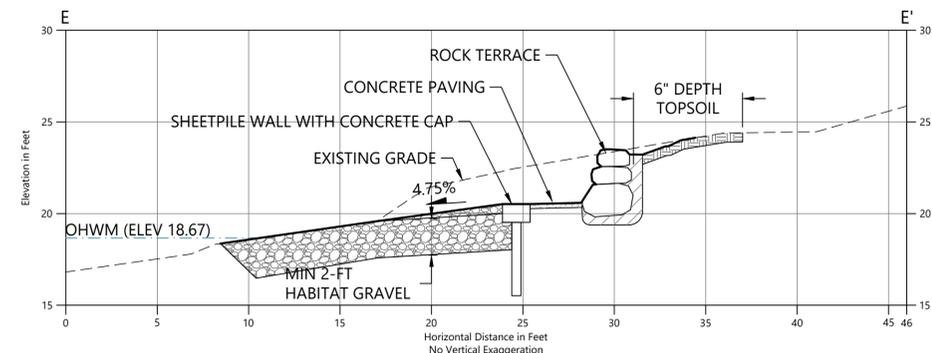

E SECTION E
SCALE: 1" = 5'

- LEGEND:**
- - - EXISTING GRADE
 - PROPOSED GRADE
 - [Pattern] HABITAT GRAVEL
 - [Pattern] ROCK TERRACE
 - [Pattern] TOPSOIL
 - [Pattern] CRUSHED GRAVEL PATHWAY



- NOTES:**
- HORIZONTAL DATUM: WASHINGTON STATE PLANE NORTH ZONE, NAD83 (2011), U.S. SURVEY FEET
 - VERTICAL DATUM: NAVD88



1601 5th Avenue, Suite 1600
Seattle, WA 98101
206.622.5822
www.kpff.com

NO.	DATE	BY	REVISION
1A	4/14/2023	RA	MIFD COMMENT REVISION



**LUTHER BURBANK PARK
WATERFRONT IMPROVEMENTS**

**CONSTRUCTION MATERIALS
CROSS-SECTIONS**

DRAWN: CW/RF	PROJECT NO.: 2200248
DESIGN: AS	SCALE: AS NOTED
CHECKED: AS/DR	DATE: 10/07/2022
DRAWING NO. CM-011	
SHEET NO. 32	OF 56

60% SUBMITTAL

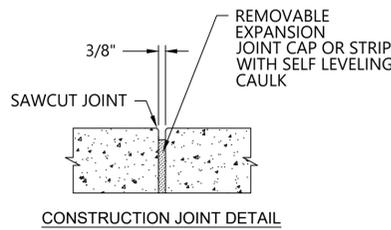
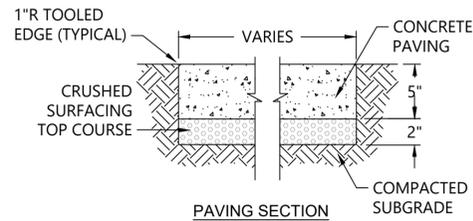
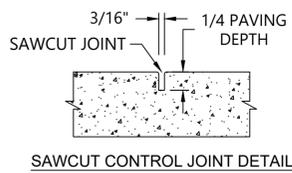
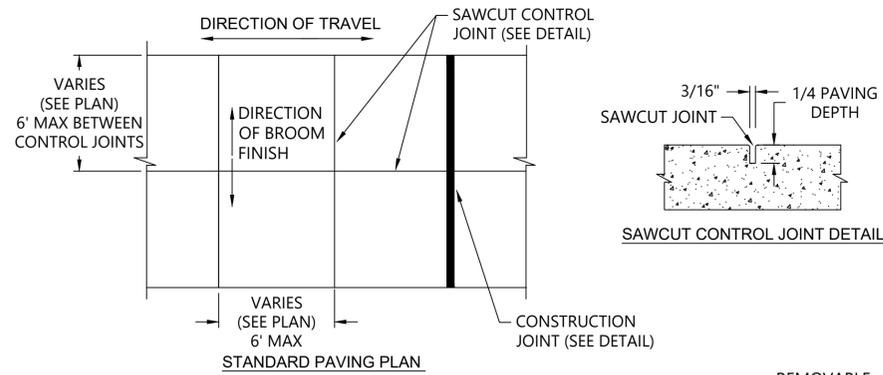

1 CONCRETE PAVING
SCALE: NTS

NOTE: CONCRETE PAVING SHALL INCLUDE FIBERMESH PER SPECIFICATIONS.

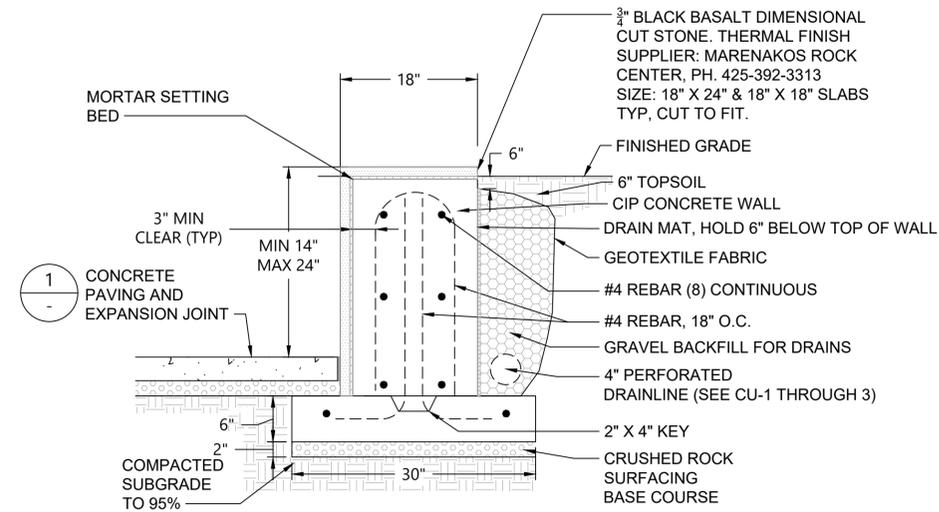

2 STONE CLAD SEAT WALL
SCALE: 1" = 1'

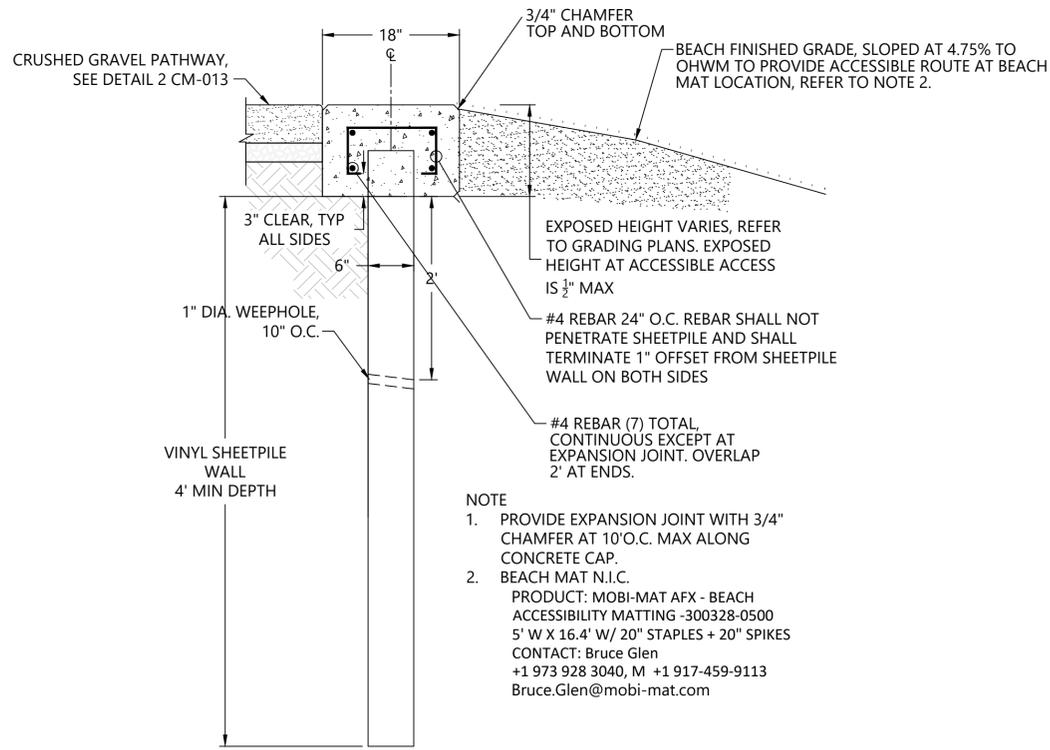

NOTE
1. PROVIDE EXPANSION JOINT WITH 3/4" CHAMFER AT 10'O.C. MAX ALONG CONCRETE CAP.
2. BEACH MAT N.I.C. PRODUCT: MOBI-MAT AFX - BEACH ACCESSIBILITY MATTING -300328-0500 5' W X 16.4' W/ 20" STAPLES + 20" SPIKES CONTACT: Bruce Glen +1 973 928 3040, M +1 917-459-9113 Bruce.Glen@mobi-mat.com

3 SHEETPILE WALL WITH CONCRETE CAP
SCALE: 1" = 1.0'

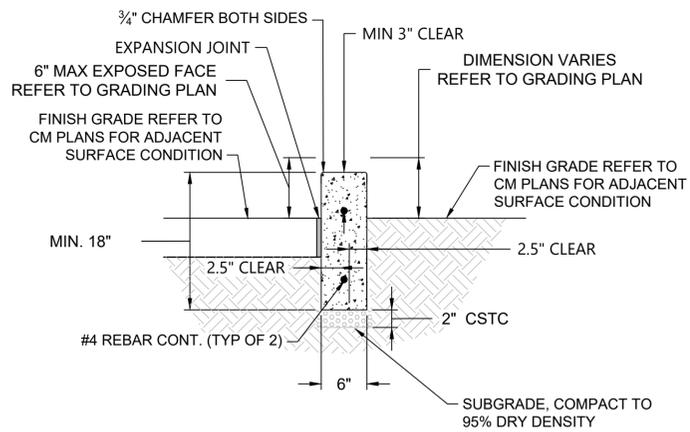

NOTES:
WHEN CONCRETE CURB IS ADJACENT TO CONCRETE PAVING, INSTALL PRE-MOLDED JOINT FILLER AT INTERFACE, USE SNAP LOCK FILLED WITH SIKA FLEX SELF-LEVELING CAULK.

4 CONCRETE CURB
SCALE: 1" = 1.0'

PLACEHOLDER - DETAIL TO BE ADDED AT 90% DESIGN

1 OUTFALL
SCALE: 1" = 1'

CAD USER: randersens PLOT DATE: Apr 13, 2023-01:13pm
PATH: K:\Projects\0159-KPFF Consulting Engineers\Mercer Island Luther Burbank Dock Repair\Construction Plans\0159-PL-CM_Details.dwg



1601 5th Avenue, Suite 1600
Seattle, WA 98101
206.622.5822
www.kpff.com

NO.	DATE	BY	REVISION
1A	4/14/2023	RA	MIFD COMMENT REVISION



LUTHER BURBANK PARK
WATERFRONT IMPROVEMENTS

CONSTRUCTION MATERIALS DETAILS
(SHEET 1 OF 4)

DRAWN: CW/RF	PROJECT NO.: 2200248
DESIGN: AS	SCALE: AS NOTED
CHECKED: AS/DR	DATE: 10/07/2022
DRAWING NO. CM-012	
SHEET NO. 33	OF 56

60% SUBMITTAL

PLACEHOLDER - DETAIL TO BE ADDED AT 90% DESIGN

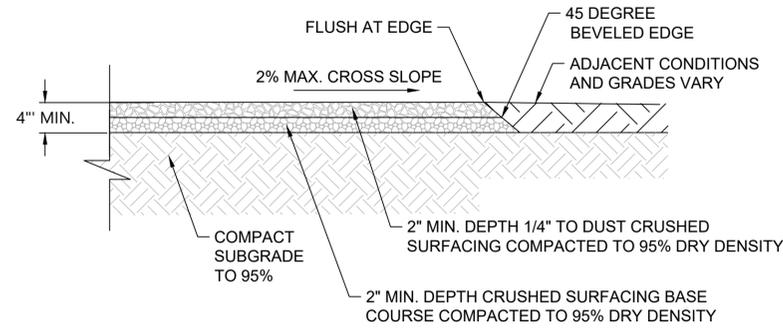

1 GRAVEL DRIVEWAY PAVING
SCALE: 1" = 1"
CM-010

2 CRUSHED GRAVEL PATHWAY
SCALE: 1" = 1"
CM-010

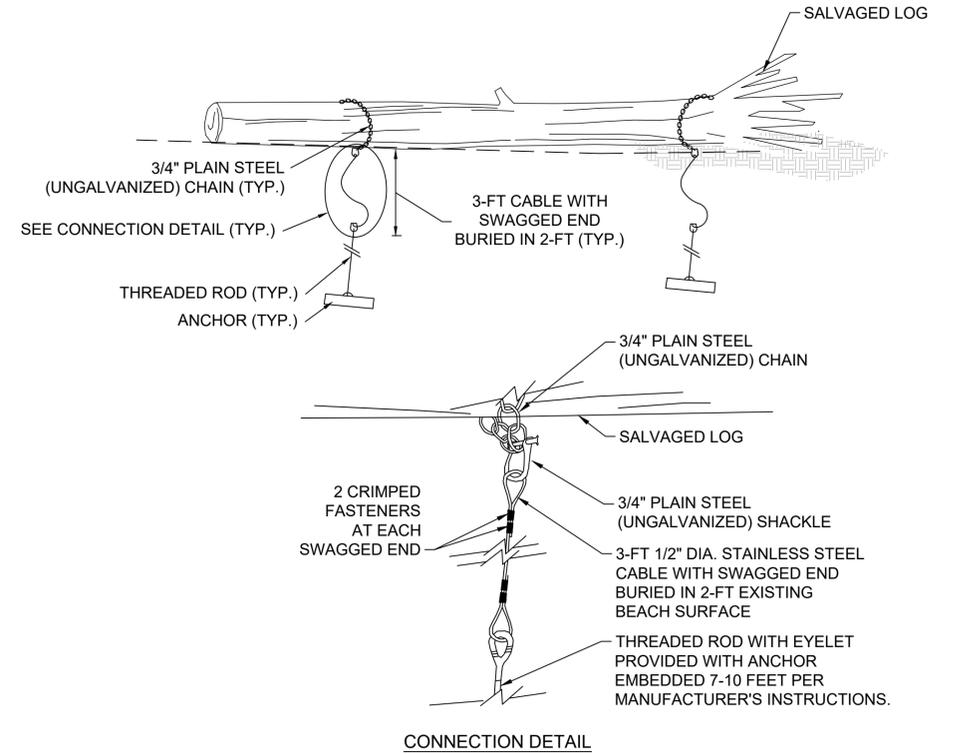

3 SALVAGED LOG
SCALE: NTS
CM-010

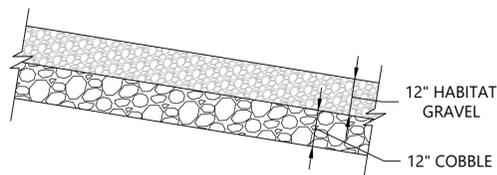

4 HABITAT GRAVEL OVER COBBLE
SCALE: NOT TO SCALE
CM-010

REFER TO WSDOT SPECIFICATION SPECIAL PROVISION 9-13.6(1) FOR HABITAT GRAVEL AND 9-13.6(2) BEACH SAND. COBBLE SHALL BE 8" STREAMBED COBBLE PER WSDOT SPECIFICATION 9-03.11(2).

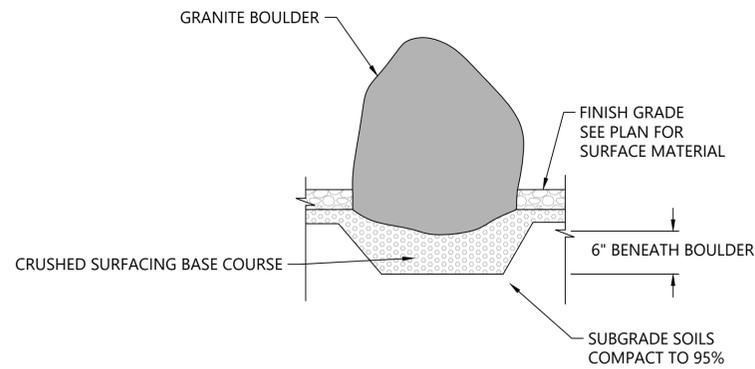

5 SALVAGED BOULDER
SCALE: NTS
CM-010

NOTE: INSTALL CRUSHED SURFACING TOP COURSE OR RECYCLED AC BASE FOR BOULDERS 4 C FEET AND LARGER. FOR BOULDERS UNDER 4 CUBIC FEET PLACE ON 95% COMPACTED SUBGRADE AND BURY IN 6-12" OF BEACH GRAVEL/RIVER ROCK.

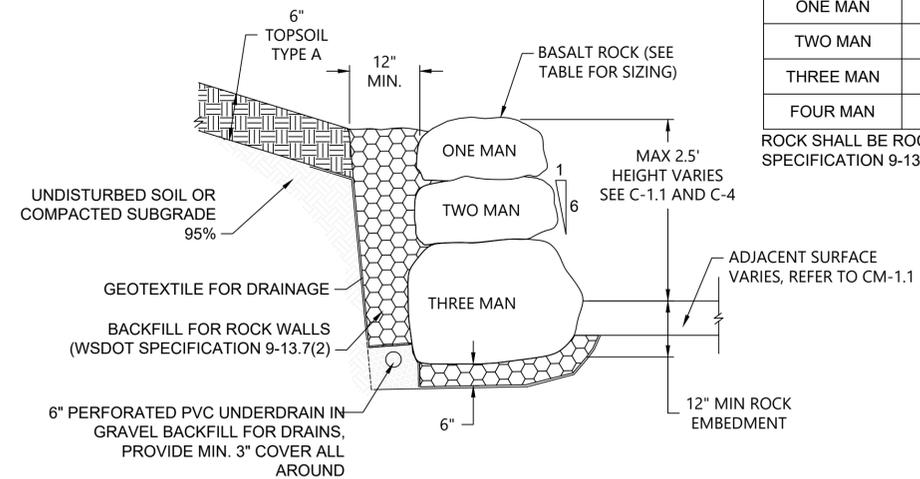

6 BASALT ROCK TERRACE
SCALE: NOT TO SCALE
CM-010

BASALT ROCK TABLE		
ROCK SIZE	ROCK WEIGHT (LBS)	AVERAGE DIMENSION (IN)
ONE MAN	50-200	12 TO 18
TWO MAN	200 TO 700	18 TO 28
THREE MAN	700 TO 2,000	28 TO 36
FOUR MAN	2,000 TO 4,000	36 TO 48

ROCK SHALL BE ROCK FOR ROCK WALL (WSDOT SPECIFICATION 9-13.7(1))

NO.	DATE	BY	REVISION
1A	4/14/2023	RA	MIFD COMMENT REVISION

BLACK BASALT STEPS
DIMENSIONAL STONE.
FINISH: THERMAL WALKING
SURFACE AND ROCKFACE
EDGES SUPPLIER:
MARENAKOS ROCK CENTER,
PH. 425-392-3313
SIZE: 6"x15"x48" TYP

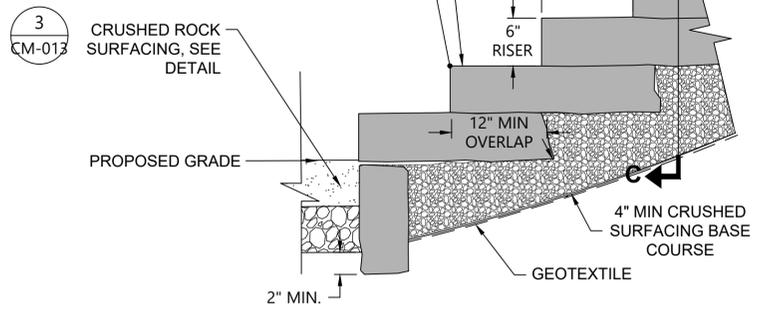

TYPICAL SECTION

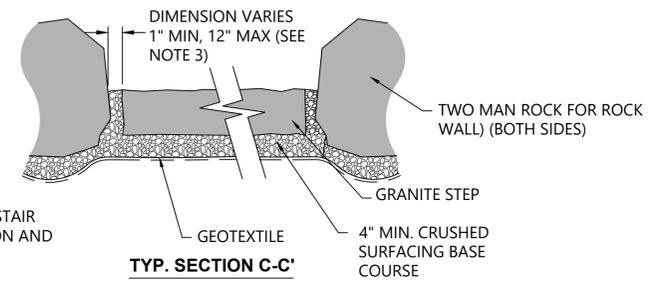

TYP. SECTION C-C'

- NOTES:
- SEE GRADING PLAN FOR TOP OF STAIR AND BOTTOM OF STAIR ELEVATION AND TREAD AND RISER COUNT
 - PLACE TWO MAN ROCK 12" MAX DISTANCE FROM GRANITE STEP TO ACCOMMODATE HANDRAIL FOOTING ONLY. PLACE TWO MAN ROCK AT 1" MIN AND 4" MAX ALONG GRANITE STEPS IN ALL OTHER AREAS.

1 STONE STAIRS
SCALE: NOT TO SCALE

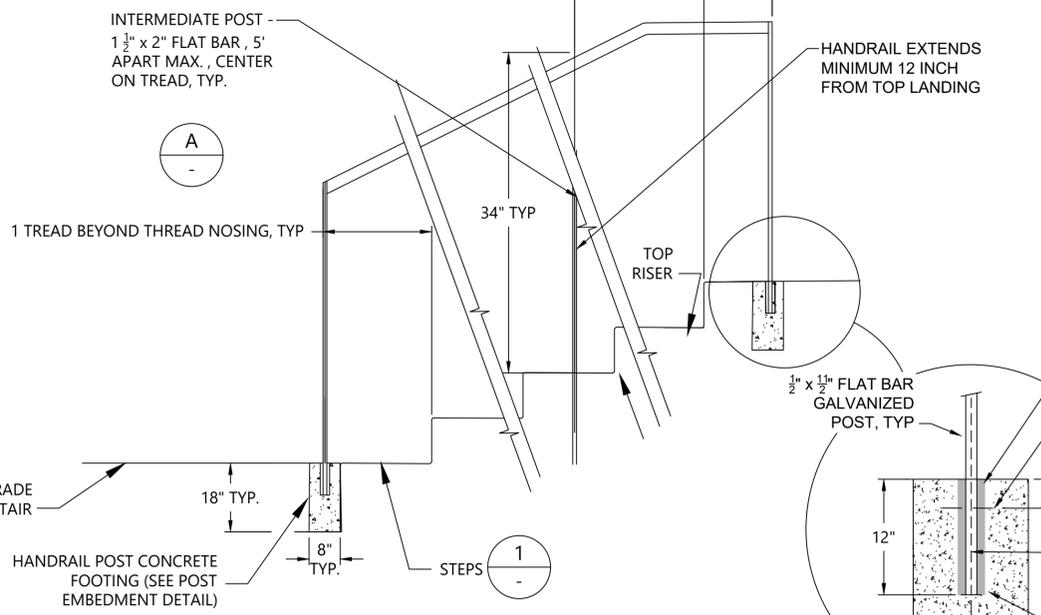

- NOTES:
- GRIND WELD JOINT SMOOTH.
 - HOT DIP GALV. AFTER FABRICATION
 - HANDRAIL TO FOLLOW ALIGNMENT SHOWN ON PLANS.
 - PROVIDE SHOP DRAWINGS.
 - FIELD MEASURE POST LOCATIONS AND FABRICATE HANDRAILING FOLLOWING STAIR INSTALLATION.
 - EMBED HANDRAIL FOOTING DIRECTLY ADJACENT TO STEP.
 - INSTALL 2 MAN BASALT EDGE STONE AFTER HANDRAIL INSTALLATION.
 - REFER TO STRUCTURAL PLANS FOR HANDRAIL AT BEACH ACCESS STEPS (SOUTH BEACH).

2 HANDRAIL AT STONE STAIRS
SCALE: NOT TO SCALE

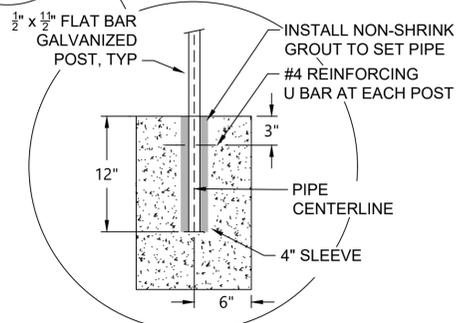

POST EMBEDMENT DETAIL
NOT TO SCALE

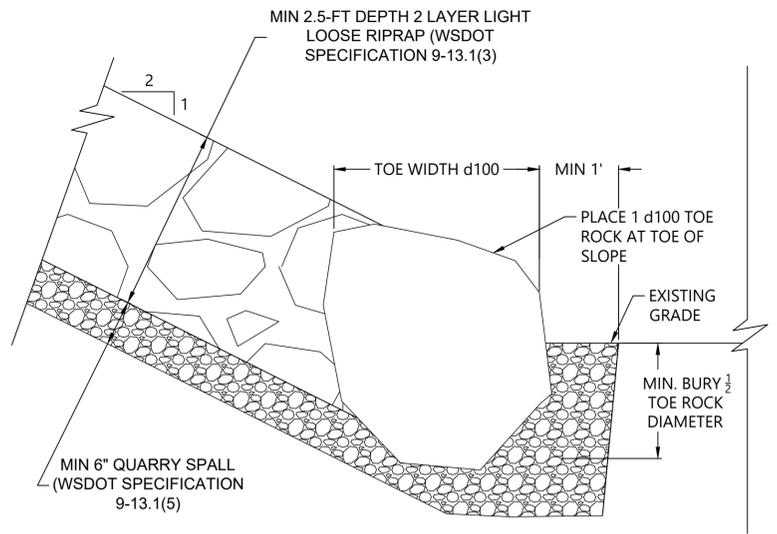

3 ROCK REVETMENT
SCALE: 1" = 1.0'

CAD USER: randers PLOT DATE: Apr 13, 2023-01:13pm
PATH: K:\Projects\0159-KPFF Consulting Engineers\Mercer Island Luther Burbank Dock Repair\Construction Plans\0159-PL-CM-Details.dwg



NO.	DATE	BY	REVISION
1A	4/14/2023	RA	MIFD COMMENT REVISION



**LUTHER BURBANK PARK
WATERFRONT IMPROVEMENTS**

**CONSTRUCTION MATERIALS DETAILS
(SHEET 3 OF 4)**

DRAWN: CW/RF	PROJECT NO.: 2200248
DESIGN: AS	SCALE: AS NOTED
CHECKED: AS/DR	DATE: 10/07/2022
DRAWING NO. CM-014	
SHEET NO. 35	OF 56

60% SUBMITTAL

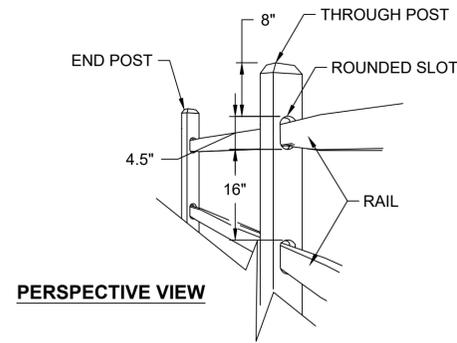

- NOTES:
1. RAIL SHALL NOT CONTINUE THROUGH END POST.
 2. STAPLE CHAINLINK FENCING TO POSTS USING 1 1/4\"/>

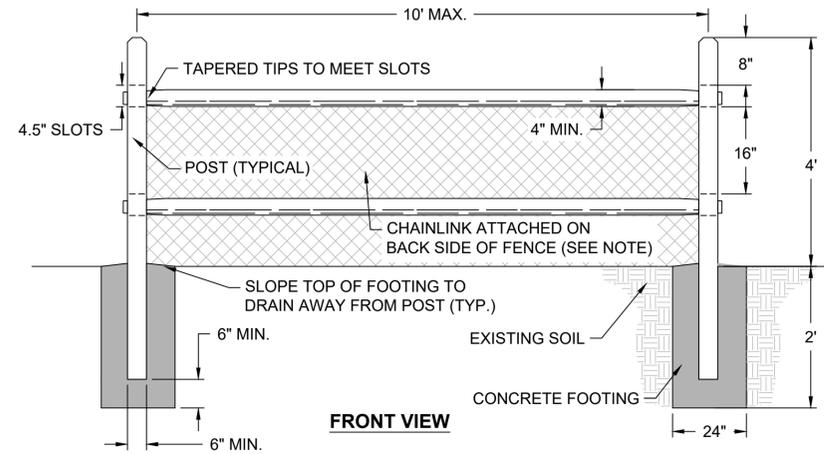

1 SPLIT RAIL FENCE
CM-010 SCALE: NTS

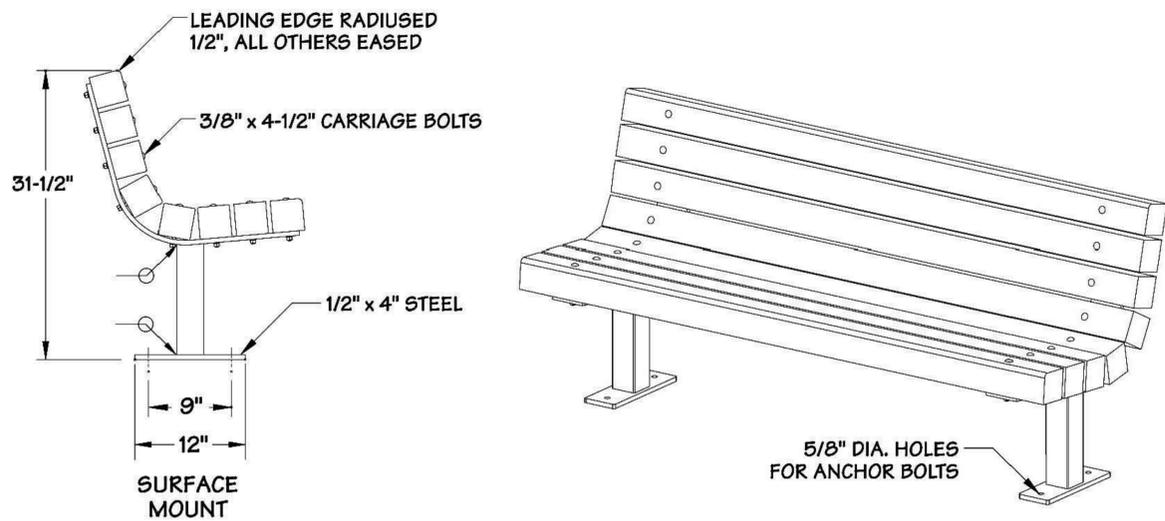

3 BENCHES
CM-010 SCALE: NTS

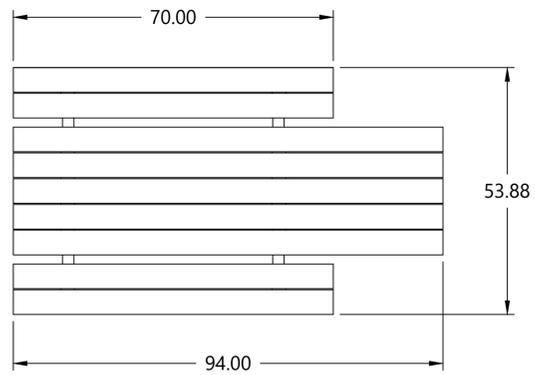

TOP VIEW

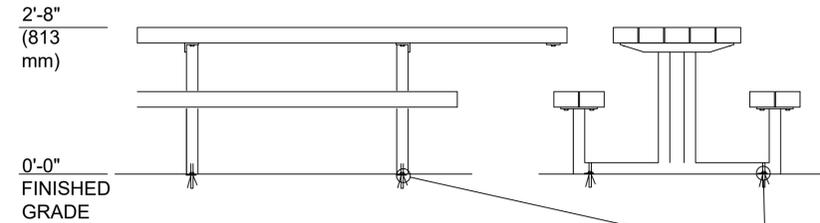

FRONT VIEW

END VIEW

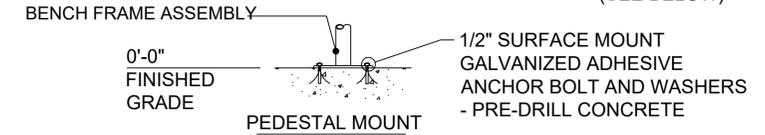

2 PICNIC TABLES
CM-010 SCALE: NTS

CAD USER: randersens PLOT DATE: Apr 13, 2023-01:13pm
PATH: K:\Projects\0159-KPFF Consulting Engineers\Mercer Island Luther Burbank Dock Repair\Construction Plans\0159-PL-CM_Details.dwg



NO.	DATE	BY	REVISION
1A	4/14/2023	RA	MIFD COMMENT REVISION



LUTHER BURBANK PARK
WATERFRONT IMPROVEMENTS

CONSTRUCTION MATERIALS DETAILS
(SHEET 4 OF 4)

DRAWN: CW/RF	PROJECT NO.: 2200248
DESIGN: AS	SCALE: AS NOTED
CHECKED: AS/DR	DATE: 10/07/2022
DRAWING NO. CM-015	
SHEET NO. 36	OF 56

60% SUBMITTAL

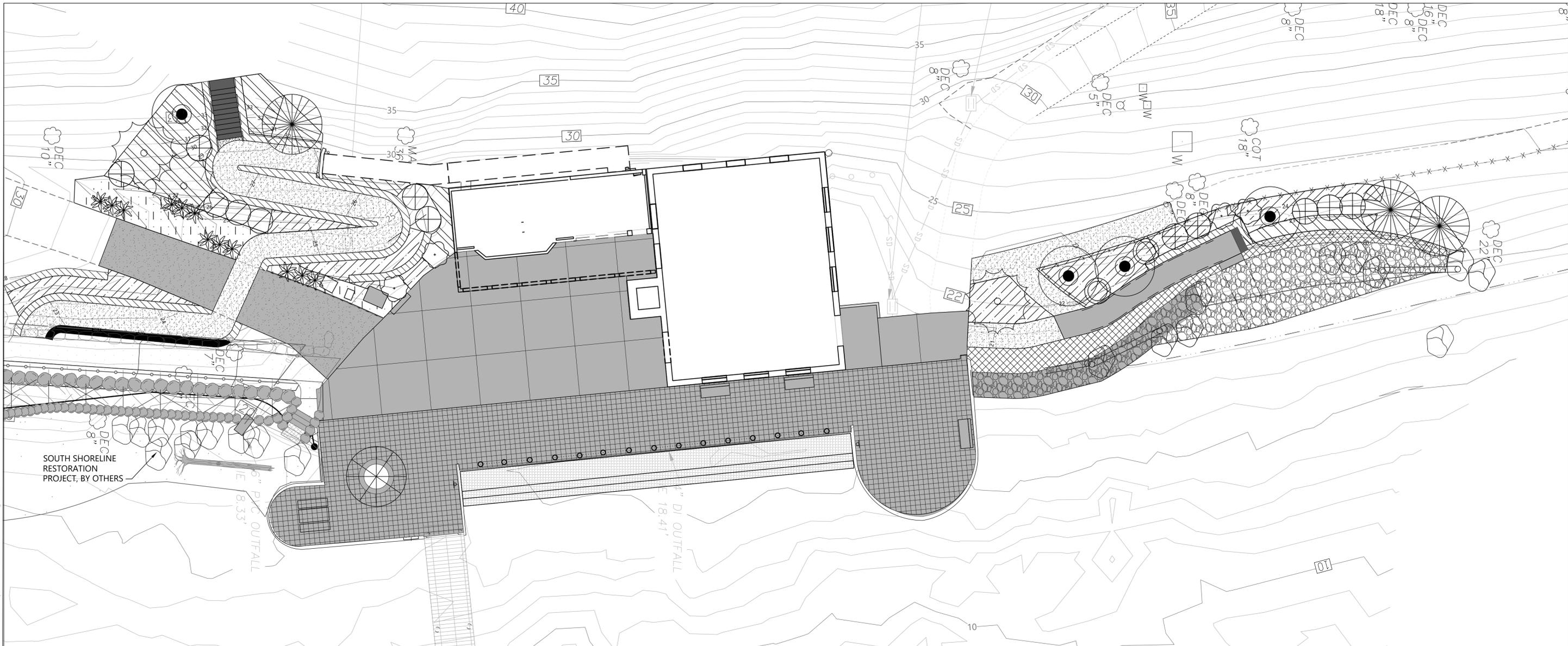

LEGEND:

- EXISTING CONTOUR
- EXISTING TREE TO RETAIN
- EXISTING LARGE WOODY DEBRIS RELOCATED
- PROPOSED TREE
- PROPOSED SHRUBS/GROUNDCOVERS
- RIPARIAN SHRUBS
- GROUNDCOVER
- STORMWATER CONVEYANCE PLANTING

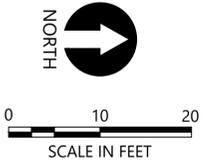

- NOTES:**
- HORIZONTAL DATUM: WASHINGTON STATE PLANE NORTH ZONE, NAD83 (2011), U.S. SURVEY FEET
 - VERTICAL DATUM: NAVD88
 - SEE SHEET L02 FOR PLANT SCHEDULE

CAD USER: randersenn PLOT DATE: Apr 13, 2023-01:14pm
 PATH: K:\Projects\0159-KPFF Consulting Engineers\Mercer Island Luther Burbank Dock Repair\Construction Plans\0159-PL-PLANTING.dwg

1601 5th Avenue, Suite 1600
 Seattle, WA 98101
 206.622.5822
 www.kpff.com

NO.	DATE	BY	REVISION
1A	4/14/2023	RA	MIFD COMMENT REVISION



**LUTHER BURBANK PARK
 WATERFRONT IMPROVEMENTS**

PLANTING PLAN

DRAWN: CW/RF	PROJECT NO.: 2200248
DESIGN: AS	SCALE: AS NOTED
CHECKED: AS/DR	DATE: 10/07/2022
DRAWING NO.	L-010
SHEET NO. 37	OF 56

60% SUBMITTAL

CAD USER: randersens PLOT DATE: Apr 13, 2023-01:14pm
 PATH: K:\Projects\0159-KPFF Consulting Engineers\Mercer Island Luther Burbank Dock Repair\Construction Plans\0159-PL-PLANTING.dwg

PLANT SCHEDULE						
COMMON NAME	SCIENTIFIC NAME	SIZE	SPACING	QUANTITY	NOTES	
TREES						
GRAND FIR	ABIES GRANDIS	5-6' HT	AS SHOWN	3		
WESTERN RED CEDAR	THUJA PLICATA	5-6' HT	AS SHOWN	3		
BIG LEAF MAPLE	ACER MACROPHYLLUM	1.5" CAL	AS SHOWN	4	1 2 3 L-012 L-012 L-012	
SWAMP OAK	QUERCUS PALUSTRIS	2" CAL	AS SHOWN	1		
VINE MAPLE	ACER CIRCINATUM	5 GAL	AS SHOWN	9		
HIGH SHRUBS						
INDIAN PLUM	OEMLERIA CERASIFORMIS	2 GAL	AS SHOWN		5 6 L-012 L-012	
MOCK ORANGE	PHILADELPHUS LEWISII	2 GAL	AS SHOWN			
SHRUBS - RIPARIAN						
SWORD FERN	POLYSTICHUM MUNITUM	1 GAL	3' O.C.			
RED FLOWERING CURRANT	RIBES SANGUINEUM	1 GAL	3' O.C.			
NOOTKA ROSE	ROSA NUTKANA	1 GAL	3' O.C.		5 6 L-012 L-012	
THIMBLEBERRY	RUBUS PARVIFLORUS	1 GAL	3' O.C.			
SNOWBERRY	SYMPHORICARPOS ALBUS	1 GAL	3' O.C.			
GROUNDCOVERS						
SWORD FERN	POLYSTICHUM MUNITUM	1 GAL	3' O.C.		4 6 L-012 L-012	
OREGON GRAPE	MAHONIA NERVOSA	1 GAL	3' O.C.			
SHRUBS/GROUNDCOVERS - STORMWATER CONVEYANCE AREA						
RED OSIER DOGWOOD	CORNUS SERICEA	1 GAL	AS SHOWN		4 5 6 L-012 L-012 L-012	
LADY FERN	ATHYRIUM FILIX FEMINA	1 GAL	AS SHOWN			
SEED MIX - STORMWATER CONVEYANCE AREA						

PLANT QUANTITIES WILL BE PROVIDED AT 90%



NO.	DATE	BY	REVISION
1A	4/14/2023	RA	MIFD COMMENT REVISION



LUTHER BURBANK PARK
WATERFRONT IMPROVEMENTS

PLANT SCHEDULE

DRAWN: CW/RF	PROJECT NO.: 2200248
DESIGN: AS	SCALE: AS NOTED
CHECKED: AS/DR	DATE: 10/07/2022
DRAWING NO.	L-011
SHEET NO. 38	OF 56

60% SUBMITTAL

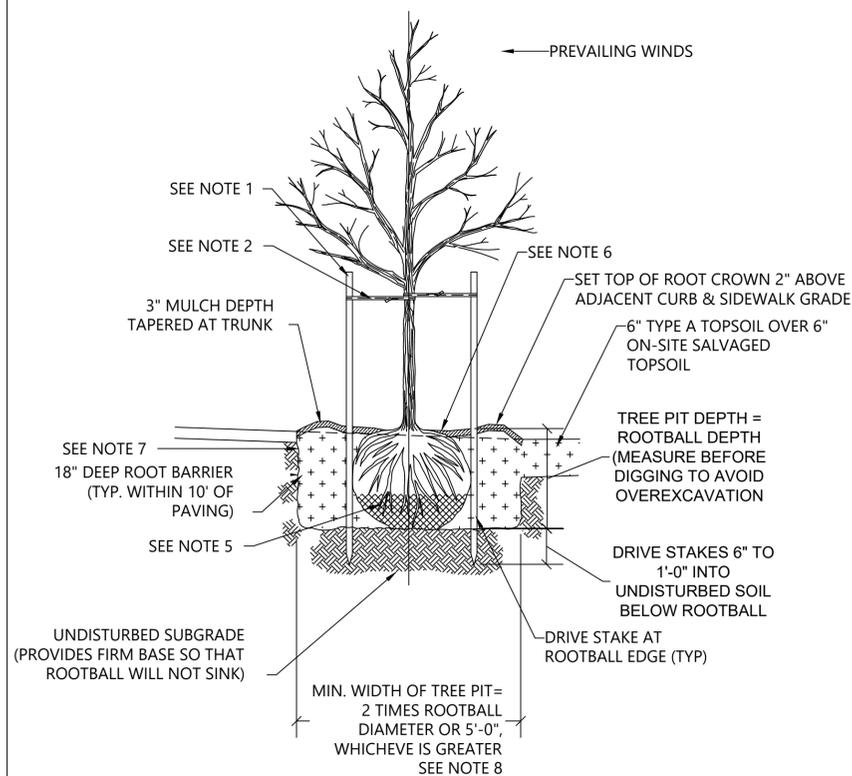

- NOTES:
1. STAKE TREES WITH (2) 2" DIAMETER (8'-0" LENGTH) LODGE POLE PINE OR DOUGLAS FIR STAKES
 2. CHAINLOCK TREE TIE. LOOP EACH TIE AROUND TREE LOOSELY TO PROVIDE 1" SLACK FOR DIAMETER GROWTH.
 3. ONE STAKE PER TREE ON WINDWARD SIDE;
 4. SECOND STAKE ON LEEWARD SIDE
 5. REMOVE ALL WIRE AND STRING. REMOVE TOP 2/3 OF BURLAP
 6. SHAPE SOIL TO PROVIDE 3' DIAMETER OR ROOTBALL DIAMETER, WHICHEVER IS GREATER, WATERING RING.
 7. ROUGHEN SIDES OF PLANTING HOLE MAXIMIZE EXCAVATED AREA WITHOUT UNDERMINING ADJACENT PAVING/CURB
 8. MULCH AREA TO BE CLEAR OF GRASS, WEEDS, ETC. TO REDUCE COMPETITION WITH TREE ROOTS

1 DECIDUOUS TREE PLANTING & STAKING
SCALE: NTS

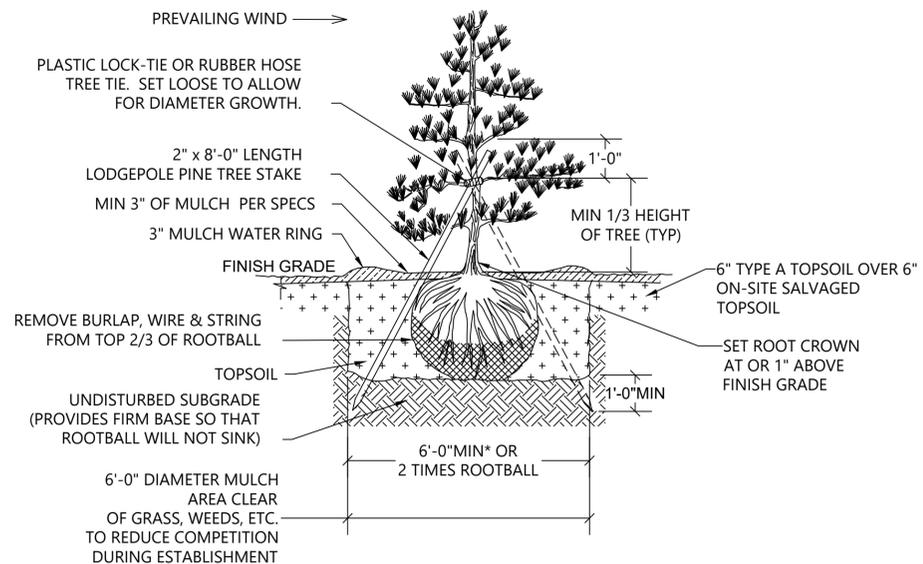

2 CONIFEROUS TREE PLANTING & STAKING
SCALE: NTS

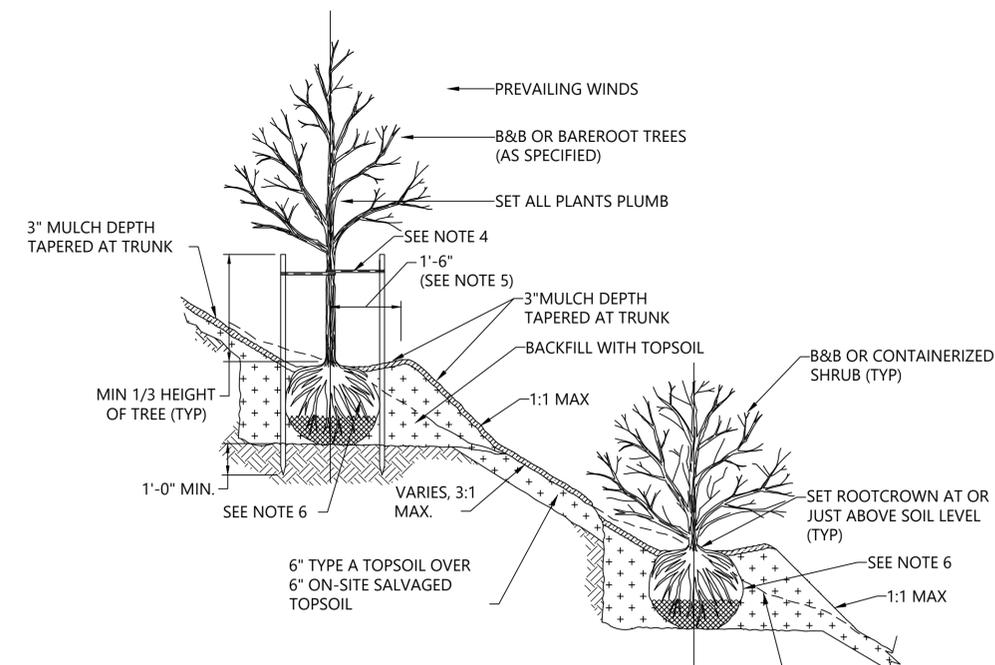

- NOTES:
1. STAKE TREES 2" DIA LODGE POLE PINE OR DOUGLAS FIR STAKES
 2. ONE STAKE PER TREE ON WINDWARD SIDE;
 3. SECOND STAKE ON LEEWARD SIDE
- SLOPES STEEPER THAN 3:1 MAY REQUIRE AN APPROVED EMBANKMENT STABILIZATION SYSTEM TO CREATE A LEVEL TREE PIT SUCH AS:
- ROCK FACING
 - PRECAST CONCRETE WALL UNITS
 - TIMBER WALL
 - MANUFACTURED SLOPE RETENTION UNITS
4. CHAINLOCK TREE TIE. LOOP EACH TIE AROUND TREE LOOSELY TO PROVIDE 1" SLACK FOR DIAMETER GROWTH.
 5. SHAPE SOIL TO PROVIDE 3' DIAMETER OR ROOTBALL DIAMETER, WHICHEVER IS GREATER, WATERING RING.
 6. REMOVE ALL WIRE AND STRING. REMOVE TOP 2/3 OF BURLAP.

3 PLANTING ON SLOPES
SCALE: NTS

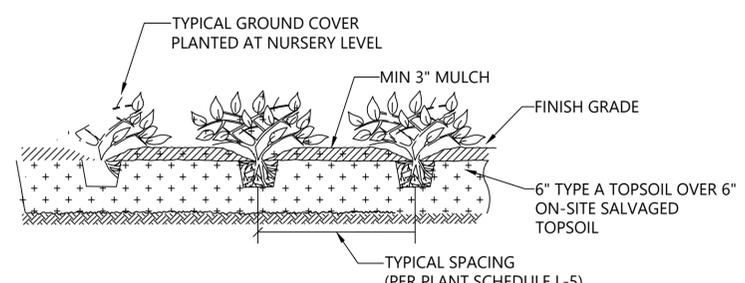

4 GROUND COVER, PERENNIAL, AND ORNAMENTAL GRASS PLANTING
SCALE: NTS

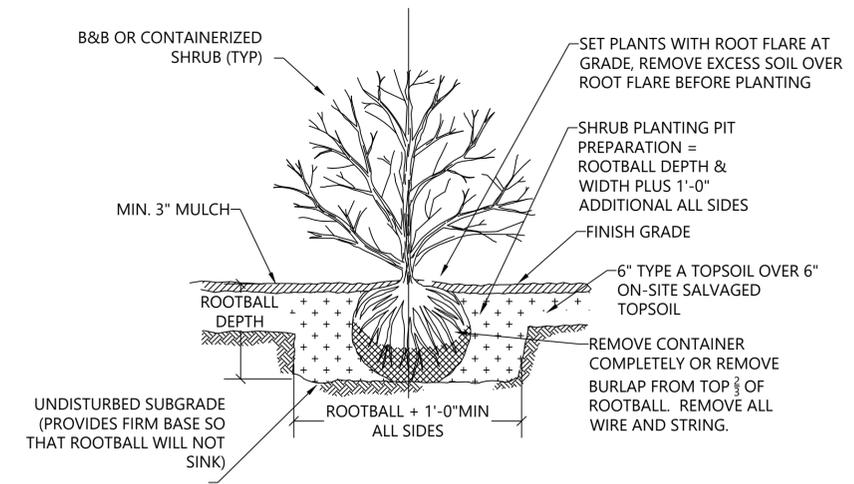

5 SHRUB PLANTING
SCALE: NTS

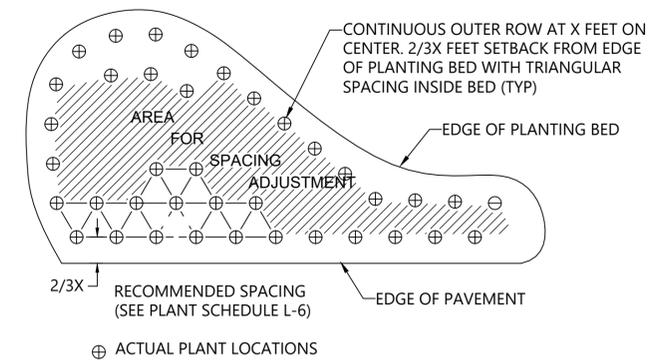

6 PLANTING PATTERN
SCALE: NTS

- NOTES: APPLY PLANTING PATTERN FOR SHRUB, GROUND COVER, GRASS, AND PERENNIAL PLANTINGS

CAD USER: randersens PLOT DATE: Apr 13, 2023-01:14pm
PATH: K:\Projects\0159-KPFF Consulting Engineers\Mercer Island Luther Burbank Dock Repair\Construction Plans\0159-PL-PLANTING.dwg



1601 5th Avenue, Suite 1600
Seattle, WA 98101
206.622.5822
www.kpff.com

NO.	DATE	BY	REVISION
1A	4/14/2023	RA	MIFD COMMENT REVISION



**LUTHER BURBANK PARK
WATERFRONT IMPROVEMENTS**

PLANTING DETAILS

DRAWN: CW/RF	PROJECT NO.: 2200248
DESIGN: AS	SCALE: AS NOTED
CHECKED: AS/DR	DATE: 10/07/2022
DRAWING NO.	L-012
SHEET NO. 39	OF 56

60% SUBMITTAL

STRUCTURAL NOTES

DESIGN LOADS

ALL DESIGN AND CONSTRUCTION SHALL CONFORM TO THE REQUIREMENTS OF THE INTERNATIONAL BUILDING CODE (IBC), 2018 EDITION, AS AMENDED BY THE CITY OF MERCER ISLAND.

DEAD LOADS (DL)

DEAD LOADS SHALL INCLUDE THE SELF WEIGHT OF MATERIALS AND COMPONENTS LISTED BELOW.

REINFORCED CONCRETE = 150 PCF
STRUCTURAL STEEL = 490 PCF
WOOD/TIMBER = 35 PCF

GANGWAY DL ASSUMED = 105 PLF (HALF SUPPORTED AT EACH END)

DESIGN FREEBOARDS UNDER DEAD LOAD: WAVE ATTENUATOR/MOORING FLOAT = 24" ±2"
FINGER FLOATS = 1'-6" ±2"
GENERAL PURPOSE FLOAT = 9" ±1"
KAYAK FINGER FLOATS = 9" ±1"
ADA KAYAK LAUNCH = 9" ±1"

FLOAT CROSS SLOPES UNDER DEAD LOAD ONLY SHALL NOT EXCEED 2% (1:50). SEE MAXIMUM SLOPES BELOW.

FLOATS CONSIST OF FLOAT CONCRETE, STRUCTURAL STEEL, WOOD/TIMBER, FLOTATION PONTOONS, FRP GRATING, FOAM, RUBRAILS, BULLRAILS, CONNECTION HARDWARE, PILE GUIDE BRACKETS, GANGWAYS AND ALL HARDWARE PERMANENTLY ATTACHED TO THE FLOATS INCLUDING STANDPIPES, ETC.

LIVE LOADS (ULL & CLL)

IN ADDITION TO THE DEAD LOADS, THE FOLLOWING LIVE LOADS SHALL BE USED FOR DESIGN. LIVE LOAD REDUCTION IS PER IBC SECTION 1607.11.

FIXED PIER = 50 PSF UNIFORM LIVE LOAD (ULL)
GANGWAYS = 100 PSF ULL (FOR DELEGATED STRUCTURAL DESIGN)
= 50 PSF ULL (FOR SUPPORT REACTIONS AT EACH END)

FLOATS = 25 PSF ULL, 400 LB CONCENTRATED LIVE LOAD (CLL)
CLL SHALL ACT OVER A 6"x6" AREA, APPLIED AT ANY POINT ON THE FLOAT
DO NOT EXCEED 12" FROM ANY EDGE.

OTHER = 100 PSF ULL, 300 LB CLL

MAXIMUM SLOPES

MAXIMUM CROSS SLOPE UNDER DL ONLY, DL + ULL, OR DL + CLL: SHALL NOT EXCEED 2% (1:50)

MAXIMUM LONGITUDINAL SLOPE UNDER DL ONLY, AND DL +ULL: 1/8 INCH PER FOOT, NOT TO EXCEED 1 INCH IN 10 FEET
UNDER DL AND CLL: 1/4 INCH PER FOOT, NOT TO EXCEED 2 INCHES IN 10 FEET

SNOW LOAD

THE SNOW LOAD IS DETERMINED USING CHAPTER 7 OF ASCE 7 IN ACCORDANCE WITH IBC SECTION 1608 AND WITH THE FOLLOWING FACTORS:

MINIMUM DESIGN LOAD 25 PSF PER MERCER ISLAND BUILDING CODE

SEISMIC LOADS

THE SEISMIC FORCE-RESISTING SYSTEM (SFRS) USED TO RESIST EARTHQUAKE AND WIND LOADS IS COMPRISED OF CANTILEVERED STEEL PILES DESIGNED TO REMAIN ELASTIC FOR CODE LEVEL EARTHQUAKE. EARTHQUAKE DESIGN IS BASED ON THE EQUIVALENT LATERAL FORCE PROCEDURE IN ASCE 7 SECTION 12.8 WITH THE FOLLOWING FACTORS:

SITE CLASS C
RISK CATEGORY II
SEISMIC DESIGN CATEGORY D
I_e = 1.00
S_s = 1.388 g
S₁ = 0.482 g
S₂ = 1.110 g
S_{0.5} = 0.483 g
T_L = ___ SECONDS
h_s = ___ FT
T = ___ SECONDS
R = 1.00
Q = ___
ρ = ___
C_s = 1.110
V = C_sW = ___ KIPS

THE SEISMIC FORCE-RESISTING SYSTEM IS COMPRISED OF THE STRUCTURAL CANTILEVERED STRUCTURAL STEEL PILES IDENTIFIED IN PLAN AND/OR ELEVATION.

WIND LOADS

WIND LOAD IS DETERMINED USING CHAPTERS 26-31 OF ASCE 7 IN ACCORDANCE WITH IBC SECTION 1609 WITH THE FOLLOWING FACTORS:

RISK CATEGORY II
EXPOSURE CATEGORY D
V = 97.5 MPH
V_{base} = 75.5 MPH
K_{zt} = 1.0
K_e = 1.0
G_{cp} = 0.0

MINIMUM WIND LOAD APPLIED TO ALL PROJECTED VERTICAL SURFACES OF DOCKS, FLOATS, AND BERTHED BOATS SHALL NOT BE LESS THAN 15 PSF, APPLIED ABOVE THE WATER SURFACE.

SOIL LOADS

ALLOWABLE SOIL-BEARING PRESSURE 4000 PSF DL + LL
5333 PSF DL + LL + SEISMIC/WIND
PILE CAPACITY 5000 PSF DOWNWARD, END BEARING
350 PSF/LF DOWNWARD, SKIN FRICTION
300 PSF/LF UPWARD, SKIN FRICTION
2000 PSF LATERAL, 0 TO 5FT
4500 PSF LATERAL, > 5FT

WAVE LOADS

	WAVE ATTENUATOR MOORING FLOAT	GENERAL PURPOSE FLOAT
50-YR WIND WAVES		
EXTREME WAVE HEIGHT	1.8 FT	1.4 FT
PERIOD	1.9 SECONDS	2.7 SECONDS
LENGTH	18.5 FT	37.2 FT
HORIZONTAL WAVE LOAD	600 PLF	200 PLF
BOAT WAKE		
EXTREME WAVE HEIGHT	1.5 FT	0.7 FT
PERIOD	1.9 SECONDS	2.7 SECONDS
LENGTH	18.5 FT	37.2 FT
HORIZONTAL WAVE LOAD	300 PLF	100 PLF

GENERAL NOTES

SUBMITTALS

SHOP DRAWINGS SHALL BE SUBMITTED TO THE ENGINEER PRIOR TO ANY FABRICATION OR CONSTRUCTION FOR ALL STRUCTURAL ITEMS, INCLUDING THE FOLLOWING: CONCRETE OR MASONRY REINFORCEMENT, EMBEDDED STEEL ITEMS, STRUCTURAL STEEL, AND GRATING.

IF THE SHOP DRAWINGS DIFFER FROM OR ADD TO THE DESIGN OF THE STRUCTURAL DRAWINGS, THEY SHALL BEAR THE SEAL AND SIGNATURE OF THE WASHINGTON STATE REGISTERED PROFESSIONAL ENGINEER WHO IS RESPONSIBLE FOR THE DESIGN.

DEFERRED SUBMITTALS

PER IBC SECTION 107.3.4.1, DRAWINGS AND CALCULATIONS FOR THE DESIGN AND FABRICATION OF ITEMS THAT ARE DESIGNED BY OTHERS SHALL BEAR THE SEAL AND SIGNATURE OF THE WASHINGTON STATE REGISTERED PROFESSIONAL ENGINEER WHO IS RESPONSIBLE FOR THE DESIGN AND SHALL BE SUBMITTED TO THE ENGINEER AND THE BUILDING DEPARTMENT FOR REVIEW PRIOR TO FABRICATION. DEFERRED SUBMITTALS INCLUDE BUT ARE NOT LIMITED TO THE FOLLOWING:

GANGWAY
WAVE ATTENUATOR/MOORING FLOAT
FINGER FLOAT
GENERAL PURPOSE FLOAT
KAYAK FINGER FLOAT
ADA KAYAK LAUNCH

NONSTRUCTURAL COMPONENTS

DESIGN, DETAILING AND ANCHORAGE OF ALL NONSTRUCTURAL COMPONENTS SHALL BE IN ACCORDANCE WITH IBC SECTION 1613, ASCE 7 CHAPTER 13, AND THE PROJECT SPECIFICATIONS. NONSTRUCTURAL COMPONENTS DESIGNED BY OTHERS SHALL NOT INDUCE TORSIONAL LOADING INTO SUPPORTING STRUCTURAL MEMBERS WITHOUT ADDITIONAL BRACING OF THOSE MEMBERS TO ELIMINATE TORSIONAL FORCES. TORSIONAL BRACING SHALL BE DESIGNED BY THE NONSTRUCTURAL COMPONENT DESIGNER AND APPROVED BY THE ENGINEER.

DESIGN, DETAILING AND CONSTRUCTION OF ALL NONSTRUCTURAL COMPONENTS WHICH ATTACH TO STRUCTURE SHALL ACCOMMODATE CONSTRUCTION TOLERANCES AS ESTABLISHED BY THE STRUCTURAL SPECIFICATIONS

INSPECTION

SPECIAL INSPECTION PER IBC CHAPTER 17 SHALL BE PERFORMED BY AN APPROVED TESTING AGENCY AS INDICATED IN THE STATEMENT OF SPECIAL INSPECTIONS AND TESTING. ALL PREPARED SOIL-BEARING SURFACES SHALL BE INSPECTED BY THE GEOTECHNICAL ENGINEER PRIOR TO PLACEMENT OF REINFORCING STEEL. SOIL COMPACTION SHALL BE SUPERVISED BY AN APPROVED TESTING AGENCY OR GEOTECHNICAL ENGINEER.

STRUCTURAL OBSERVATION

STRUCTURAL OBSERVATION OF THE SFRS WILL BE PERFORMED BY THE STRUCTURAL ENGINEER OF RECORD IN ACCORDANCE WITH IBC SECTION 1704.6. STRUCTURAL OBSERVATION CONSISTS OF VISUAL OBSERVATION OF THE STRUCTURAL SYSTEMS FOR GENERAL CONFORMANCE TO THE CONSTRUCTION DOCUMENTS AND DOES NOT INCLUDE OR WAIVE THE RESPONSIBILITY FOR THE INSPECTIONS REQUIRED BY THE IBC AND AS SHOWN IN THE SPECIAL INSPECTIONS SCHEDULE. CONTRACTOR SHALL PROVIDE A MINIMUM OF 72 HOURS NOTICE BEFORE CONCEALING THE FOLLOWING STRUCTURAL COMPONENTS FROM VIEW:

REINFORCING STEEL FOR THE FIRST PLACEMENT OF THE FOLLOWING ELEMENTS: SFRS PILE CAPS.

STRUCTURAL OBSERVATIONS IN ADDITION TO THOSE REQUIRED BY IBC SECTION 1704.6 MAY BE PERFORMED AT THE ENGINEER'S DISCRETION. TIMING OF THESE SHALL BE DISCUSSED AT THE PREINSTALLATION CONFERENCE.

SPECIAL CONDITIONS

CONTRACTOR SHALL VERIFY ALL LEVELS, DIMENSIONS, AND EXISTING CONDITIONS IN THE FIELD BEFORE PROCEEDING. CONTRACTOR SHALL NOTIFY THE ENGINEER OF ANY DISCREPANCIES OR FIELD CHANGES PRIOR TO INSTALLATION OR FABRICATION. IN CASE OF DISCREPANCIES BETWEEN THE EXISTING CONDITIONS AND THE DRAWINGS, THE CONTRACTOR SHALL OBTAIN DIRECTION FROM THE ENGINEER BEFORE PROCEEDING. DIMENSIONS NOTED AS PLUS OR MINUS (±) INDICATE UNVERIFIED DIMENSIONS AND ARE APPROXIMATE. NOTIFY ENGINEER IMMEDIATELY OF CONFLICTS OR EXCESSIVE VARIATIONS FROM INDICATED DIMENSIONS. NOTED DIMENSIONS TAKE PRECEDENCE OVER SCALED DIMENSIONS—DO NOT SCALE DRAWINGS. DIMENSIONS OF EXISTING CONDITIONS ARE BASED ON THE 1973 PIER PLANS AND 1988 FINGER PIER PLANS AND ARE TO BE FIELD-VERIFIED BY THE CONTRACTOR.

CONTRACTOR SHALL VERIFY ALL EXISTING CONDITIONS BEFORE COMMENCING ANY DEMOLITION. CONTRACTOR SHALL PROVIDE ADEQUATE SHORING AND BRACING OF ALL STRUCTURAL MEMBERS, EXISTING CONSTRUCTION AND SOIL EXCAVATIONS, AS REQUIRED, AND IN A MANNER SUITABLE TO THE WORK SEQUENCE. TEMPORARY SHORING AND BRACING SHALL NOT BE REMOVED UNTIL ALL FINAL CONNECTIONS HAVE BEEN COMPLETED IN ACCORDANCE WITH THE DRAWINGS AND MATERIALS HAVE ACHIEVED DESIGN STRENGTH.

FIELD LOCATE REINFORCING BARS, TENDONS, AND EMBEDS AND PROVIDE A MINIMUM OF 2' CLEARANCE TO ALL CONCRETE CORES AND CUTS. NO REINFORCING BARS, TENDONS, OR EMBEDS IN EXISTING CONSTRUCTION SHALL BE CUT UNLESS DIRECTED TO BY THE ENGINEER OR AS SHOWN ON THE DRAWINGS.

CONTRACTOR SHALL BE RESPONSIBLE FOR ALL SAFETY PRECAUTIONS AND THE METHODS, TECHNIQUES, SEQUENCES OR PROCEDURES REQUIRED TO PERFORM THE WORK.

SOILS

SEE THE GEOTECHNICAL REPORT BY GEOENGINEERS, INC. DATED _____ FOR MORE COMPLETE INFORMATION. EARTHWORK MATERIAL, BACKFILL AND COMPACTION SHALL BE IN ACCORDANCE WITH THE RECOMMENDATIONS OF THE GEOTECHNICAL REPORT. BACKFILL BEHIND WALLS SHALL NOT BE PLACED BEFORE THE WALLS AND SUPPORTING SLABS ACHIEVE 28 DAY CONCRETE STRENGTH OR THE WALLS ARE TEMPORARILY BRACED. ALL TOPSOIL ORGANICS AND LOOSE SURFACE SOIL SHALL BE REMOVED FROM BENEATH FILL SUPPORTING CONCRETE SLABS OR PAVING.

MEMBER SPACING

ALL FRAMING MEMBERS SHALL BE EQUALLY SPACED BETWEEN GRID LINES, COLUMNS, AND DIMENSIONED FRAMING UNLESS NOTED OTHERWISE.

CONCRETE

CONCRETE WORK SHALL CONFORM TO ALL REQUIREMENTS OF IBC CHAPTER 19.

CONCRETE MIXTURES

CONCRETE MIXTURES SHALL CONFORM TO THE FOLLOWING REQUIREMENTS:

f'c(Psi)	TEST AGE(DAYS)	EXPOSURE CLASS				USE
		F	S	W	C	
4,000	28	F_	S_	W_	C_	FOUNDATIONS, CONCRETE PILE CAPS

CONCRETE MIXTURES SHALL CONFORM TO THE MOST STRINGENT REQUIREMENTS FOR EXPOSURE CLASSES SPECIFIED IN THE TABLE ABOVE AND ACI 318 TABLE 19.3.2.1.

WATER-REDUCING ADMIXTURES MAY BE INCORPORATED IN CONCRETE MIX DESIGNS, BUT SHALL CONFORM TO ASTM C 494, AND BE USED IN STRICT ACCORDANCE WITH THE MANUFACTURER'S RECOMMENDATIONS. CaCl₂ OR OTHER WATER-SOLUBLE CHLORIDE ADMIXTURES SHALL NOT BE USED.

WATER/CEMENTITIOUS MATERIALS RATIO SHALL BE MEASURED BY WEIGHT AND SHALL BE BASED ON THE TOTAL CEMENTITIOUS MATERIAL. WATER/CEMENTITIOUS MATERIALS RATIO AND WATER CONTENT SHALL BE DETERMINED BY THE SUPPLIER BASED ON STRENGTH REQUIREMENTS AND SHALL NOT EXCEED THE MAXIMUM WATER/CEMENTITIOUS MATERIAL RATIO AND/OR WATER CONTENT IF SHOWN ABOVE OR IN ACI 318 TABLE 19.3.2.1 FOR THE EXPOSURE CLASSES LISTED.

FIELD-MEASURED SLUMP SHALL CONFORM TO THE SUBMITTED CONCRETE MIX DESIGN. TOLERANCE OF SLUMP SHALL CONFORM TO ASTM C 94.

ALL CONCRETE SUBJECT TO EXPOSURE CLASSES F1, F2 OR F3 SHALL BE AIR ENTRAINED. AIR-ENTRAINING AGENTS SHALL CONFORM TO ASTM C 260. THE AMOUNT OF ENTRAINED AIR SHALL BE ACCORDING TO ACI 318 TABLE 19.3.3.1 WITH A FIELD TOLERANCE OF ±1.5 PERCENT BY VOLUME. THE AMOUNT OF ENTRAINED AIR SHALL BE MEASURED IN THE FIELD AT THE DISCHARGE FROM THE TRUCK.

THE CONTRACTOR SHALL SUBMIT CONCRETE MIX DESIGNS FOR APPROVAL 2 WEEKS PRIOR TO PLACING ANY CONCRETE. THE MIX DESIGN SHALL BE IN CONFORMANCE WITH ACI 318, CHAPTER 19. THE SUBMITTAL SHALL INDICATE WHERE EACH CONCRETE MIX IS TO BE USED ON THE PROJECT, AS WELL AS THE MAXIMUM AGGREGATE SIZE OF EACH MIX. MAXIMUM AGGREGATE SIZE SHALL CONFORM TO THE PROJECT SPECIFICATIONS.

CURING

IF THE AIR TEMPERATURE WILL EXCEED 75 DEGREES F WITHIN 48 HOURS OF PLACING CONCRETE, A MOIST CURE SHALL BE APPLIED TO THE CONCRETE FOR A PERIOD OF 36 HOURS AFTER FINISHING CONCRETE SURFACES. REFER TO THE PROJECT SPECIFICATIONS FOR CURING REQUIREMENTS.

REINFORCING STEEL

DEFORMED BARS ASTM A 615, GRADE 60
HEADED DEFORMED BARS ASTM A 970, HEAD TYPE HA

REINFORCING SHALL BE SUPPORTED AS SPECIFIED BY THE PROJECT SPECIFICATIONS AND THE CRSI MANUAL OF STANDARD PRACTICE. REINFORCING STEEL SHALL BE DETAILED IN ACCORDANCE WITH ACI STANDARD OF PRACTICE AS OUTLINED IN ACI 315, "GUIDE TO PRESENTING REINFORCING STEEL DESIGN DETAILS".

LAP ALL REINFORCING BARS AS NOTED ON THE DRAWINGS. WHERE SPLICE LENGTH IS NOT SHOWN, USE TYPE Lb (Lb FOR TOP BARS) SPLICE PER DEVELOPMENT AND SPLICE LENGTH SCHEDULE. MECHANICAL SPLICES CALLED OUT ON THE PLANS SHALL BE TYPE 1, UNLESS OTHERWISE NOTED. TYPE 1 SPLICES SHALL DEVELOP 125 PERCENT OF THE YIELD CAPACITY OF THE SPLICED BARS IN BOTH TENSION AND COMPRESSION. TYPE 2 SPLICES SHALL DEVELOP THE SPECIFIED TENSILE STRENGTH OF THE SPLICED BARS IN TENSION IN ADDITION TO MEETING TYPE 1 SPLICE REQUIREMENTS. SUBMIT ICC-ES OR IAPMO UES REPORT VALID FOR THE 2018 IBC DEMONSTRATING COMPLIANCE OF COUPLERS WITH THESE REQUIREMENTS.

AT THE CONTRACTOR'S OPTION AND WITH THE ENGINEER'S APPROVAL, HEADED DEFORMED BARS MAY BE USED IN LIEU OF REINFORCING BARS SHOWN WITH STANDARD 90 OR 180 DEGREE HOOKS AND MECHANICAL SPLICES MAY BE USED IN LIEU OF LAP SPLICES. USE OF HEADED DEFORMED BARS IS SUBJECT TO CONFORMANCE WITH ACI 318 SECTION 25.4.4. USE OF MECHANICAL SPLICES IS SUBJECT TO CONFORMANCE WITH ACI 318 SECTION 18.2.7 AND REQUIRES SUBMITTAL OF AN ICC-ES OR IAPMO UES REPORT VALID FOR THE 2018 IBC.

REINFORCING STEEL SHALL HAVE PROTECTION AS FOLLOWS, UNLESS NOTED OTHERWISE:

USE	COVER
BEAM STIRRUPS AND COLUMN TIES	1 1/2"
NONSTRUCTURAL SLAB-ON-GRADE	PER DETAILS
STRUCTURAL SLAB-AT-GRADE BOTTOM BARS	2"
WALL BARS:	
EXPOSED TO EARTH OR WEATHER	1 1/2" (#5 AND SMALLER)
FOOTING, PILE CAP, GRADE BEAM BOTTOM BARS	2" (#6 AND LARGER)
TOP BARS	3" (CAST AGAINST EARTH)
SIDE BARS	1 1/2" (#6 AND LARGER WHERE EXPOSED TO EARTH OR WEATHER)
SIDE BARS	2"

WELDING OF REINFORCING, WHERE APPROVED BY THE ENGINEER, SHALL BE PERFORMED USING LOW HYDROGEN ELECTRODES AND PREHEATED IN ACCORDANCE WITH AWS D1.4, REINFORCING STEEL WELDING CODE. WELDERS AND WELDING PROCEDURES SHALL BE QUALIFIED IN ACCORDANCE WITH AWS D1.4. MATERIALS SHALL CONFORM TO THE FOLLOWING:

REINFORCING BARS TO BE WELDED ASTM A 706, GRADE 60, LOW ALLOY
WELDING ELECTRODES E80XX

NONSHRINK GROUT

BASE PLATE GROUT SHALL BE NONSHRINK TYPE WITH MINIMUM f'c = 8,000 PSI. ALL OTHER NONSHRINK GROUT SHALL HAVE MINIMUM f'c = 5,000 PSI.

ABBREVIATIONS LIST

±	PLUS OR MINUS, TOLERANCE, CONTRACTOR VERIFY
@	AT
ADA	AMERICANS WITH DISABILITIES ACT
APPROX	APPROXIMATE, APPROXIMATELY
BLDG	BUILDING
BTM	BOTTOM
CL, C	CENTERLINE
CLR	CLEAR
CONC	CONCRETE
CONN	CONNECTION
CONT	CONTINUOUS
DBL	DOUBLE
DIA, Ø	DIAMETER
EA	EACH
EG	EXISTING GRADE
EL, ELEV	ELEVATION
EQ	EQUAL, EQUALLY
EXIST, (E)	EXISTING
FDC	FIRE DEPARTMENT CONNECTION
FRP	FIBERGLASS REINFORCED PLASTIC
GALV	GALVANIZED
HDG	HOT DIPPED GALVANIZED
HSS	HOLLOW STRUCTURAL SECTION
IE	INVERT ELEVATION
INFO	INFORMATION
JT	JOINT
L	ANGLE
LB	POUND
MAX	MAXIMUM
MB	MALLEABLE BOLT
MIN	MINIMUM
NTS	NOT TO SCALE
OC	ON CENTER
OHWM	ORDINARY HIGH WATER MARK, ELEVATION 18.67
OLWM	ORDINARY LOW WATER MARK, ELEVATION 16.75
OPP	OPPOSITE
PCF	POUNDS PER CUBIC FOOT
PL	PLATE
PLF	POUNDS PER LINEAR FOOT
PT	PRESSURE TREATED
REINF	REINFORCEMENT
SIM	SIMILAR
SPA	SPACED, SPACING, SPACES
ST	STEEL
SYMM	SYMMETRY, SYMMETRICAL
TYP	TYPICAL
UHMMW	ULTRA HIGH MOLECULAR WEIGHT
UNO	UNLESS NOTED OTHERWISE
UV	ULTRA VIOLET
VIF	VERIFY IN FIELD
w/	WITH
WP	WORK POINT



1601 5th Avenue, Suite 1600
Seattle, WA 98101
206.622.5822
www.kpff.com

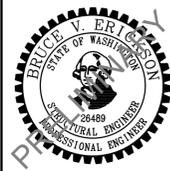

NO.	DATE	BY	REVISION
1	4/14/2023	WBC	LAND USE PERMIT REVISION
1A	4/14/2023	WBC	MIFD COMMENT REVISION



LUTHER BURBANK PARK
WATERFRONT IMPROVEMENTS

STRUCTURAL NOTES

DRAWN: RRT	PROJECT NO.: 2200248
DESIGN: WBC	SCALE: AS SHOWN
CHECKED: AKB	DATE: 10/7/2022
DRAWING NO.	S-001
SHEET NO.	40 of 56

60% SUBMITTAL

CAD USER: RICKT PLOT DATE: Apr 12, 2023-11:05am
PATH: V:\2000291 (Luther Burbank Pier Repairs)\02_Design (v2019)\LBPR_S-003.dwg



1601 5th Avenue, Suite 1600
Seattle, WA 98101
206.622.5822
www.kpff.com

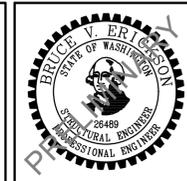

NO.	DATE	BY	REVISION
1A	4/14/2023	WBC	MIFD COMMENT REVISION



LUTHER BURBANK PARK
WATERFRONT IMPROVEMENTS

STATEMENT OF SPECIAL INSPECTIONS

DRAWN: RRT	PROJECT NO.: 2200248
DESIGN: WBC	SCALE: AS SHOWN
CHECKED: AKB	DATE: 10/7/2022
DRAWING NO.	S-003
SHEET NO.	42 OF 56



60% SUBMITTAL

Xrefs:
 xLBPR-BDR22x34
 42000291_TOPOBDM
 xLBPR-PIER
 DNR Lease No 20-A09917 12-23-2015_WBC

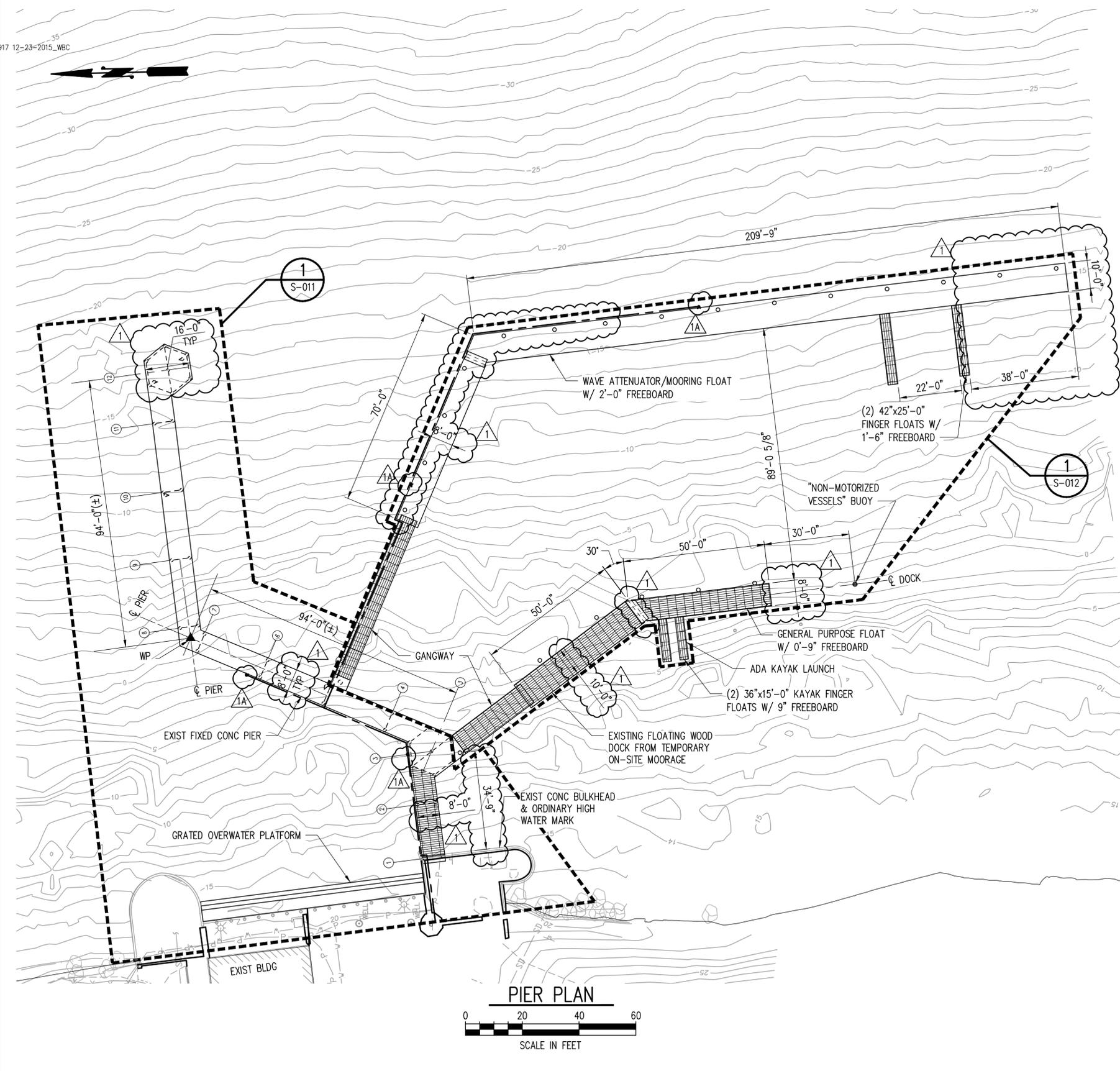

PIER PLAN
 SCALE IN FEET

NOTES:

1. PROPOSED IMPROVEMENTS OVERWATER COVERAGE: ±4425 SF.
2. EXTENDS TO EXISTING BOUNDARY CORNER AT N 217653.411, E 1297450.919.
3. EXTENDS TO EXISTING BOUNDARY CORNER AT N 220320.192, E 1296873.931.

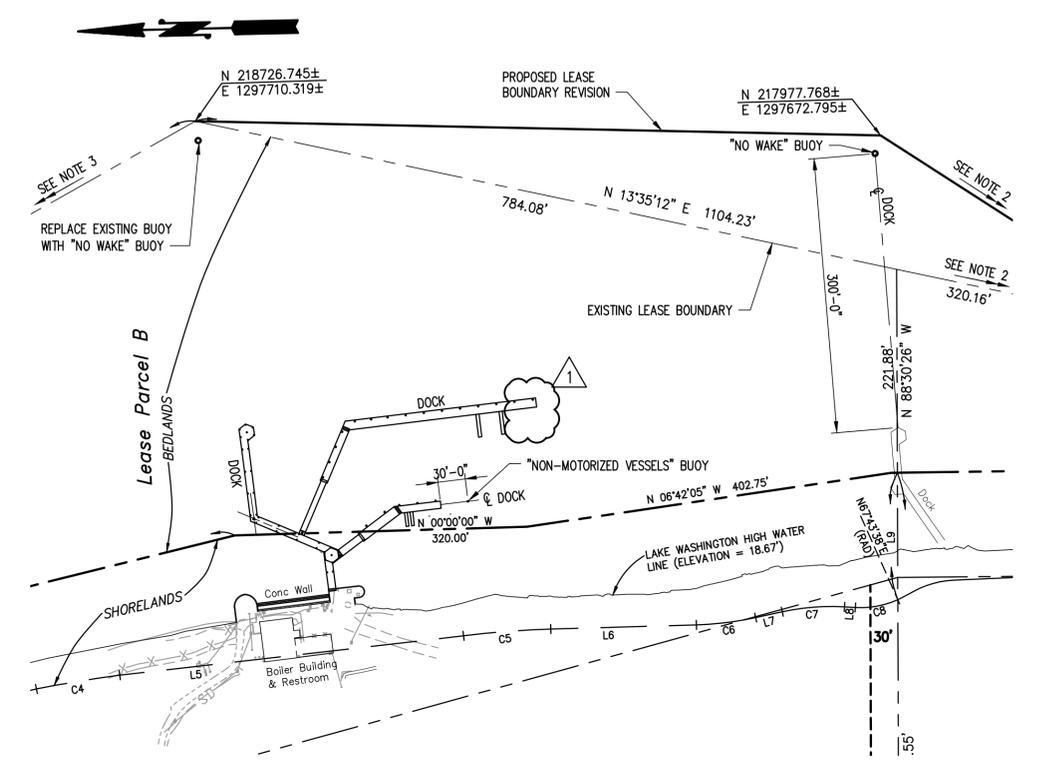

BUOY PLAN
 SCALE IN FEET

CAD USER: RICKT PLOT DATE: Apr 12, 2023-11:40am
 PATH: V:\2000291 (Luther Burbank Pier Repairs)\02_Design (v2019)\LBPR_S-010.dwg

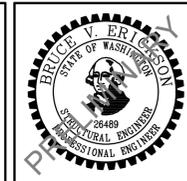

NO.	DATE	BY	REVISION
1	4/14/2023	WBC	LAND USE PERMIT REVISION
1A	4/14/2023	WBC	MIFD COMMENT REVISION



**LUTHER BURBANK PARK
 WATERFRONT IMPROVEMENTS**

PIER IMPROVEMENT PLAN

DRAWN: RRT	PROJECT NO.: 2200248
DESIGN: WBC	SCALE: AS SHOWN
CHECKED: AKB	DATE: 10/7/2022
DRAWING NO.	S-010
SHEET NO.	43 OF 56

60% SUBMITTAL

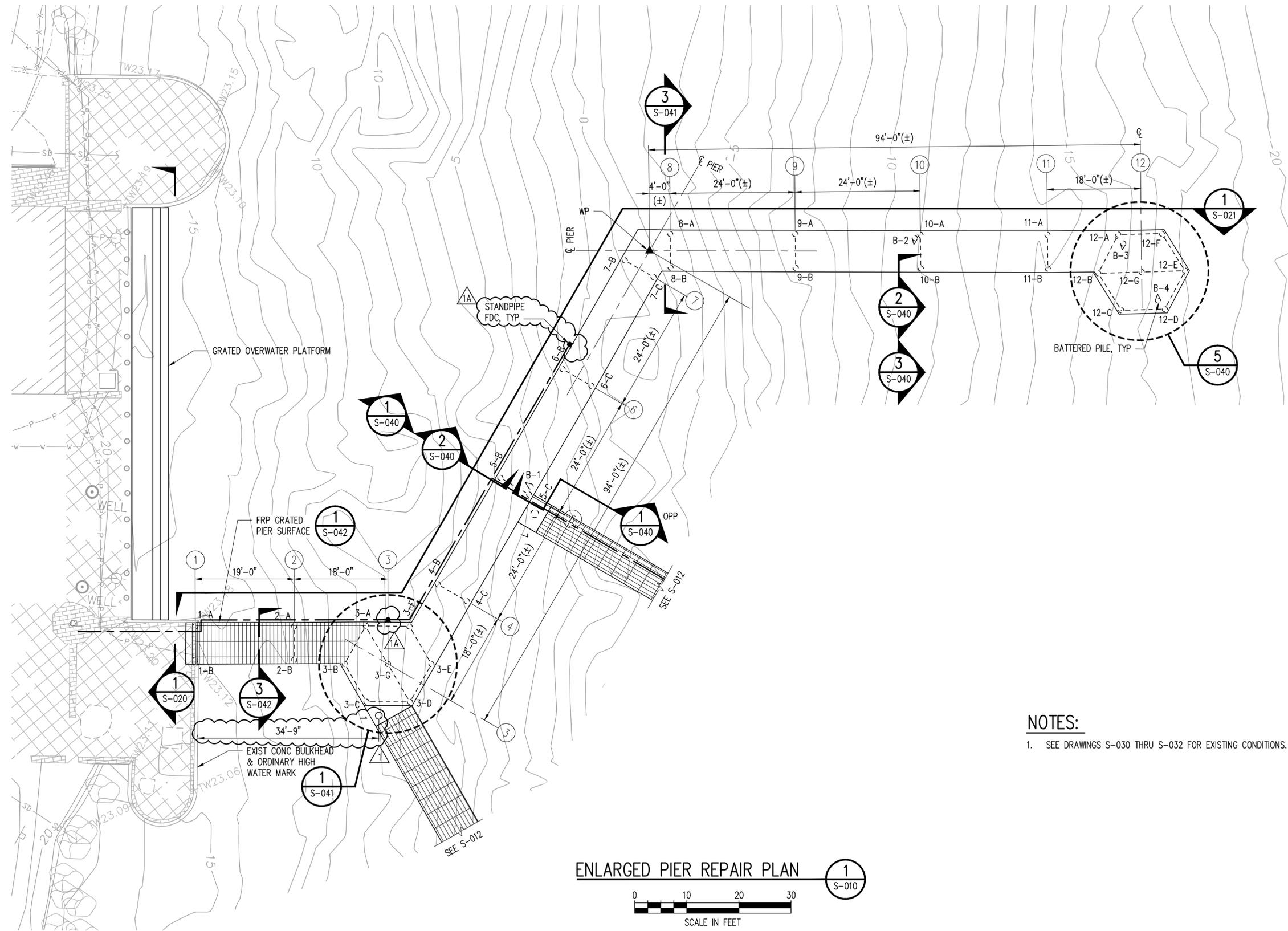

NOTES:
 1. SEE DRAWINGS S-030 THRU S-032 FOR EXISTING CONDITIONS.

ENLARGED PIER REPAIR PLAN 1
 S-010

0 10 20 30
 SCALE IN FEET

CAD USER: RICKT PLOT DATE: Apr 12, 2023-02:00pm
 PATH: V:\2000291 (Luther Burbank Pier Repairs)\02_Design (v2019)\LBPR_S-011.dwg

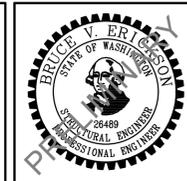

NO.	DATE	BY	REVISION
1	4/14/2023	WBC	LAND USE PERMIT REVISION
1A	4/14/2023	WBC	MIFD COMMENT REVISION



LUTHER BURBANK PARK
 WATERFRONT IMPROVEMENTS

ENLARGED PIER REPAIR PLAN

DRAWN: RRT	PROJECT NO.: 2200248
DESIGN: WBC	SCALE: AS SHOWN
CHECKED: AKB	DATE: 10/7/2022
DRAWING NO.	S-011
SHEET NO.	44 OF 56

60% SUBMITTAL

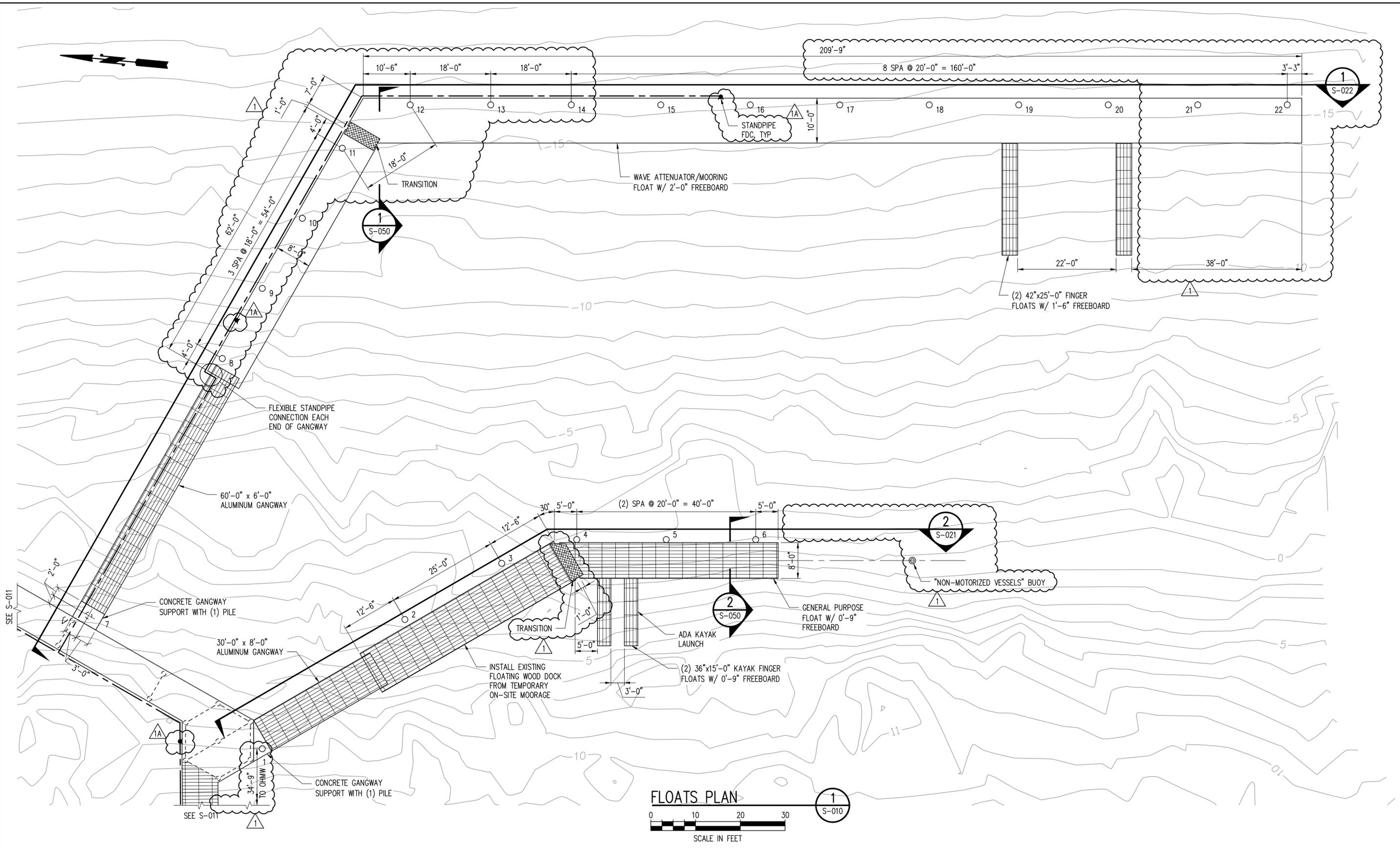

FLOATS PLAN
 0 10 20 30
 SCALE IN FEET

CAD USER: RICKT PLOT DATE: Apr 12, 2023-01:52pm
 PATH: V:\2000291 (Luther Burbank Pier Repairs)\02_Design (v2019)\LBPR_S-012.dwg

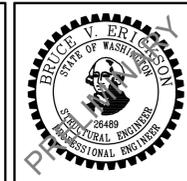

NO.	DATE	BY	REVISION
1	4/14/2023	WBC	LAND USE PERMIT REVISION
1A	4/14/2023	WBC	MIFD COMMENT REVISION



**LUTHER BURBANK PARK
 WATERFRONT IMPROVEMENTS**

FLOATS PLAN

DRAWN: RRT	PROJECT NO.: 2200248
DESIGN: WBC	SCALE: AS SHOWN
CHECKED: AKB	DATE: 10/7/2022
DRAWING NO.	S-012
SHEET NO.	45 OF 56

60% SUBMITTAL

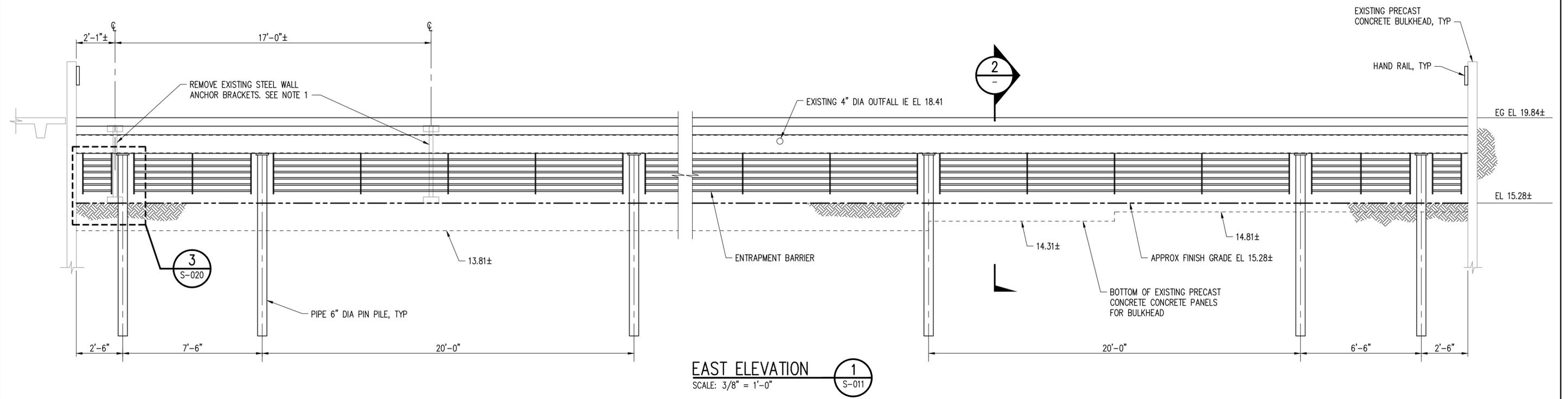

EAST ELEVATION
SCALE: 3/8" = 1'-0"
1
S-011

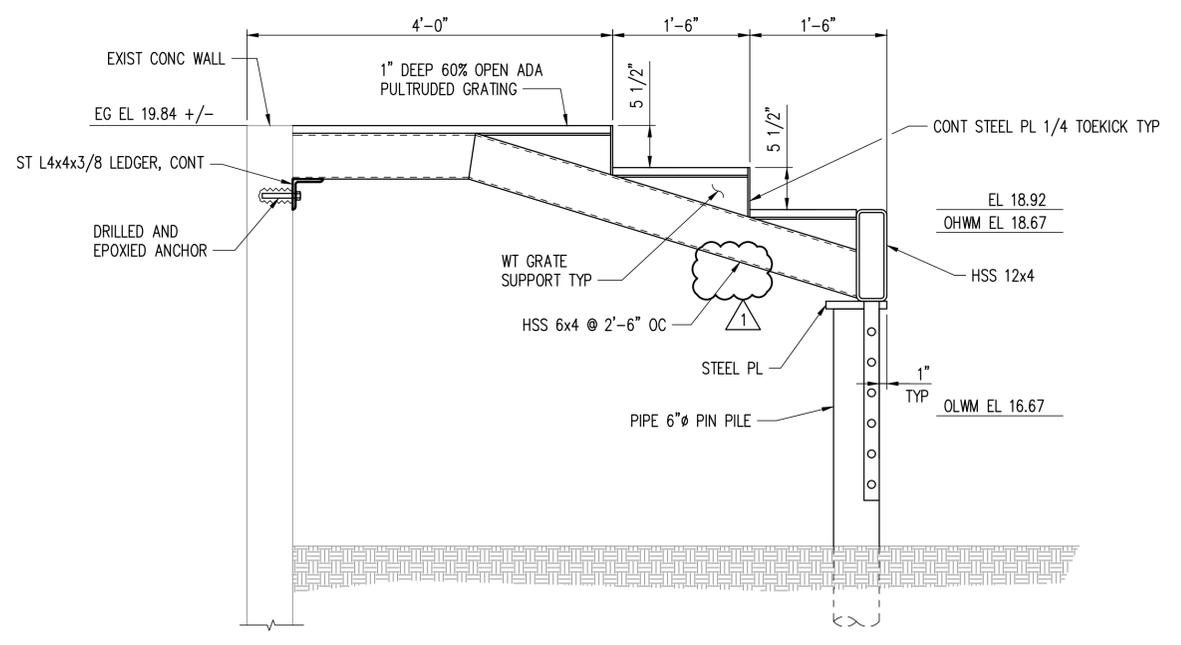

SECTION
SCALE: 1" = 1'-0"
2

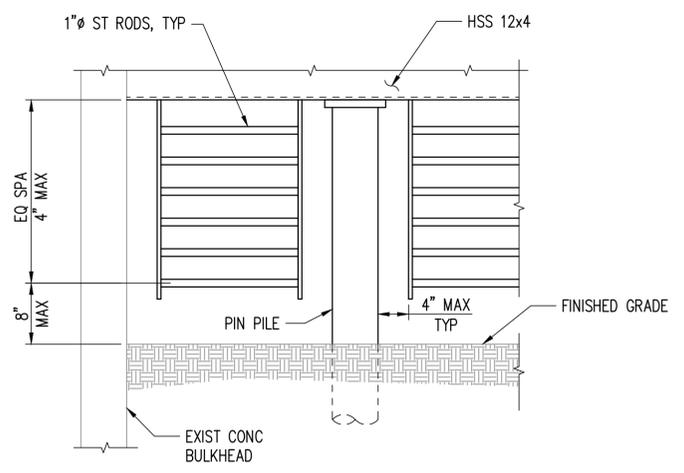

DETAIL
SCALE: 1" = 1'-0"
3

NOTES:

- EXISTING BRACKETS ARE ATTACHED TO WALL W/ (3) 5/8"Ø STEEL BOLTS. REMOVE BRACKET AND CUT AND GRIND BOLTS FLUSH TO WALL SURFACE.

CAD USER: RICKT PLOT DATE: Apr 12, 2023-01: 44pm
PATH: V:\2000291 (Luther Burbank Pier Repairs)\02_Design (v2019)\LBPR_S-020.dwg

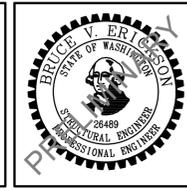

NO.	DATE	BY	REVISION
1	4/14/2023	WBC	LAND USE PERMIT REVISION
1A	4/14/2023	WBC	MIFD COMMENT REVISION



LUTHER BURBANK PARK
WATERFRONT IMPROVEMENTS

GRATED OVERWATER PLATFORM DETAILS

DRAWN: RRT	PROJECT NO.: 2200248
DESIGN: WBC	SCALE: AS SHOWN
CHECKED: AKB	DATE: 10/7/2022
DRAWING NO.	S-020
SHEET NO.	46 OF 56

60% SUBMITTAL

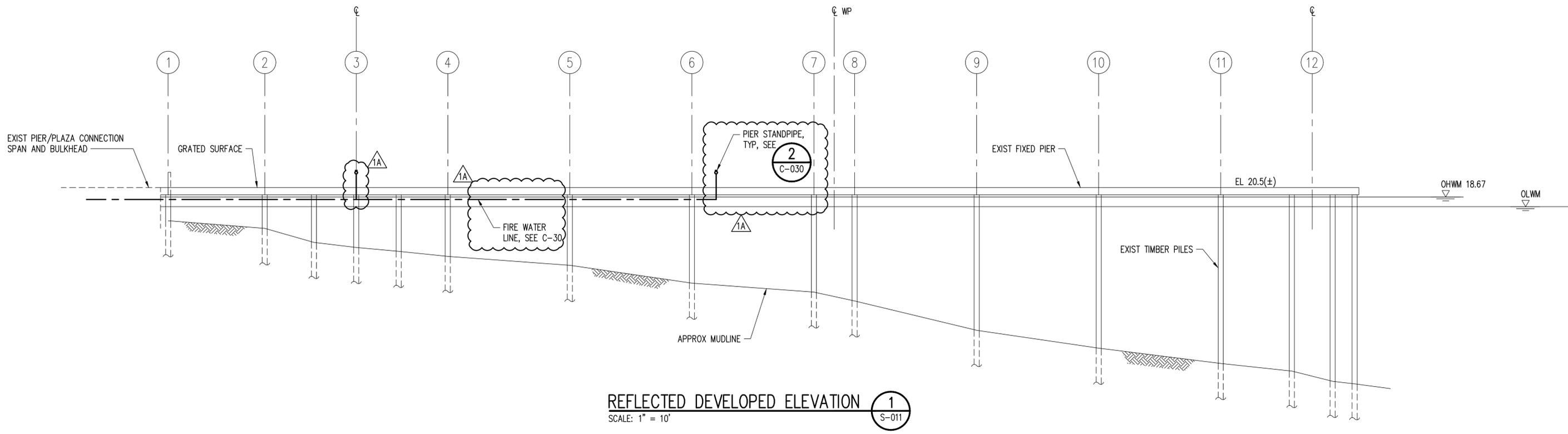

REFLECTED DEVELOPED ELEVATION **1**
SCALE: 1" = 10' S-011

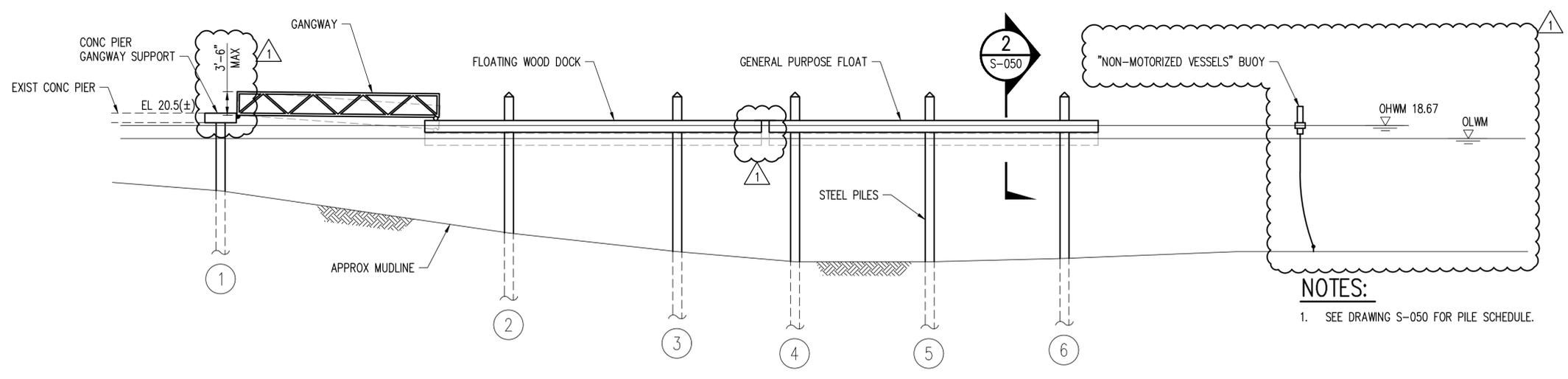

REFLECTED DEVELOPED ELEVATION **2**
SCALE: 1" = 10' S-012

NOTES:
1. SEE DRAWING S-050 FOR PILE SCHEDULE.

CAD USER: RICKT PLOT DATE: Apr 12, 2023-02:09pm
PATH: V:\2000291 (Luther Burbank Pier Repairs)\02_Design (v2019)\LBPR_S-021.dwg

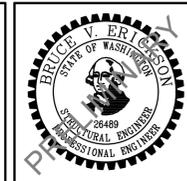

NO.	DATE	BY	REVISION
1	4/14/2023	WBC	LAND USE PERMIT REVISION
1A	4/14/2023	WBC	MIFD COMMENT REVISION



**LUTHER BURBANK PARK
WATERFRONT IMPROVEMENTS**

PIER AND FLOATS ELEVATION

DRAWN: RRT	PROJECT NO.: 2200248
DESIGN: WBC	SCALE: AS SHOWN
CHECKED: AKB	DATE: 10/7/2022
DRAWING NO.	S-021
SHEET NO.	47 OF 56

60% SUBMITTAL

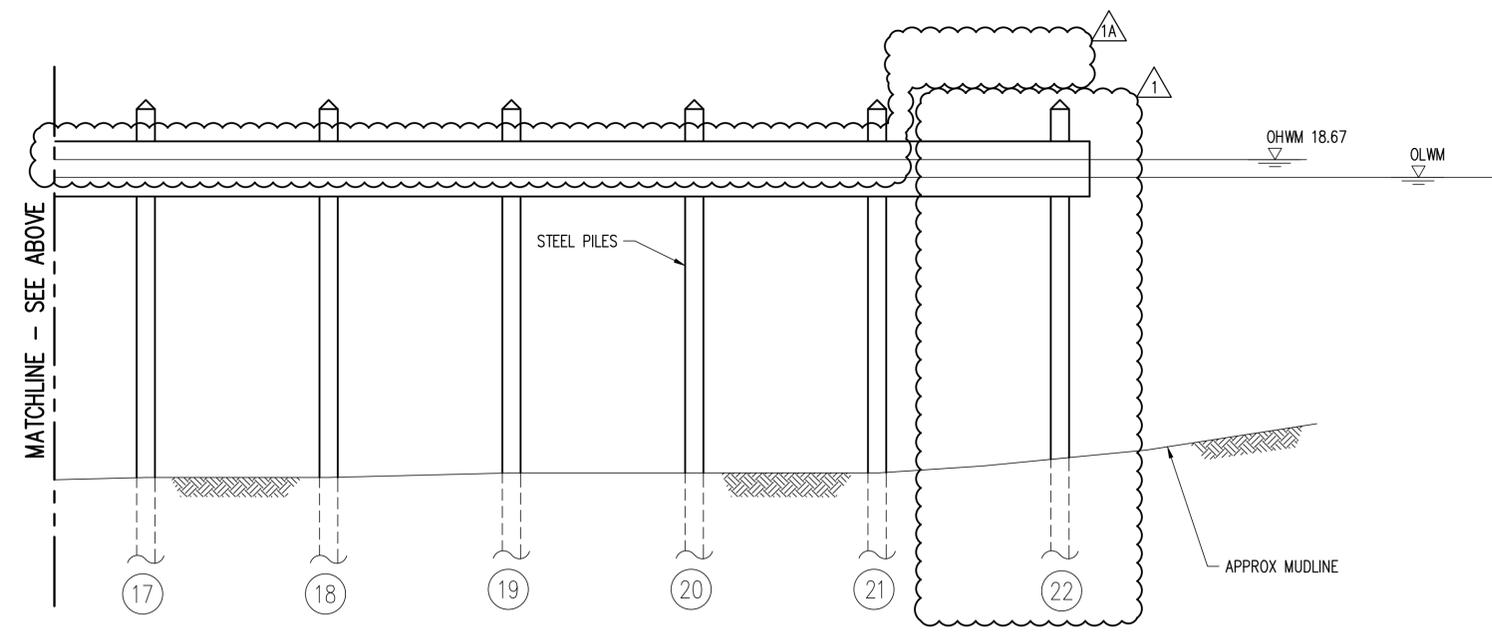
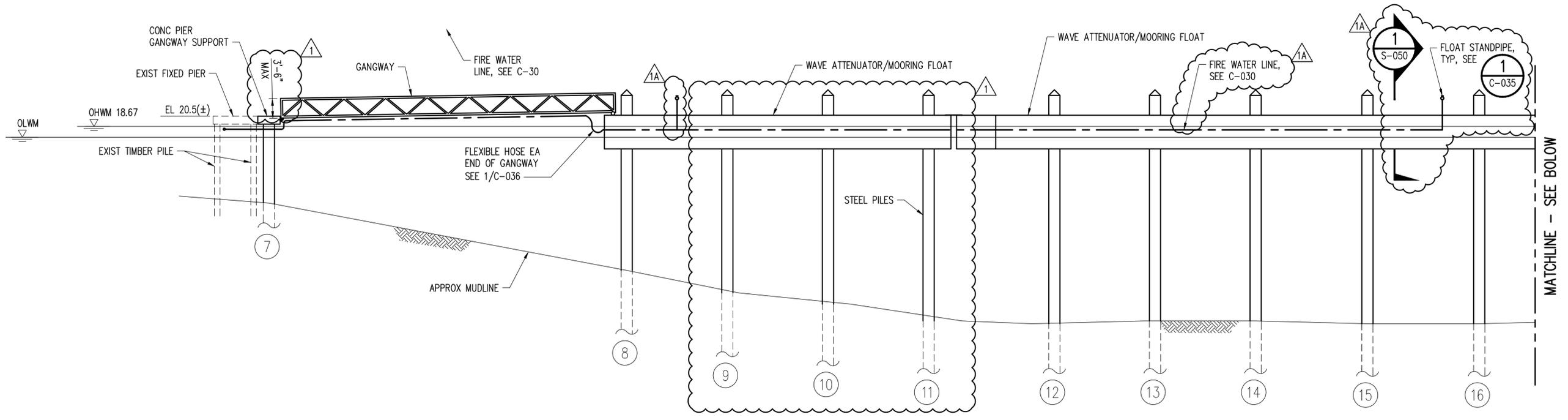

REFLECTED DEVELOPED ELEVATION 1
SCALE: 1" = 10' S-012

NOTES:
1. SEE DRAWING S-050 FOR PILE SCHEDULE.

CAD USER: RICKT PLOT DATE: Apr 12, 2023-03:03pm
PATH: V:\2000291 (Luther Burbank Pier Repairs)\02_Design (v2019)\LBPR_S-022.dwg

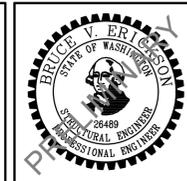

NO.	DATE	BY	REVISION
1	4/14/2023	WBC	LAND USE PERMIT REVISION
1A	4/14/2023	WBC	MIFD COMMENT REVISION



**LUTHER BURBANK PARK
WATERFRONT IMPROVEMENTS**

PIER AND FLOATS ELEVATION

DRAWN: RRT	PROJECT NO.: 2200248
DESIGN: WBC	SCALE: AS SHOWN
CHECKED: AKB	DATE: 10/7/2022
DRAWING NO.	S-022
SHEET NO.	48 OF 56

60% SUBMITTAL

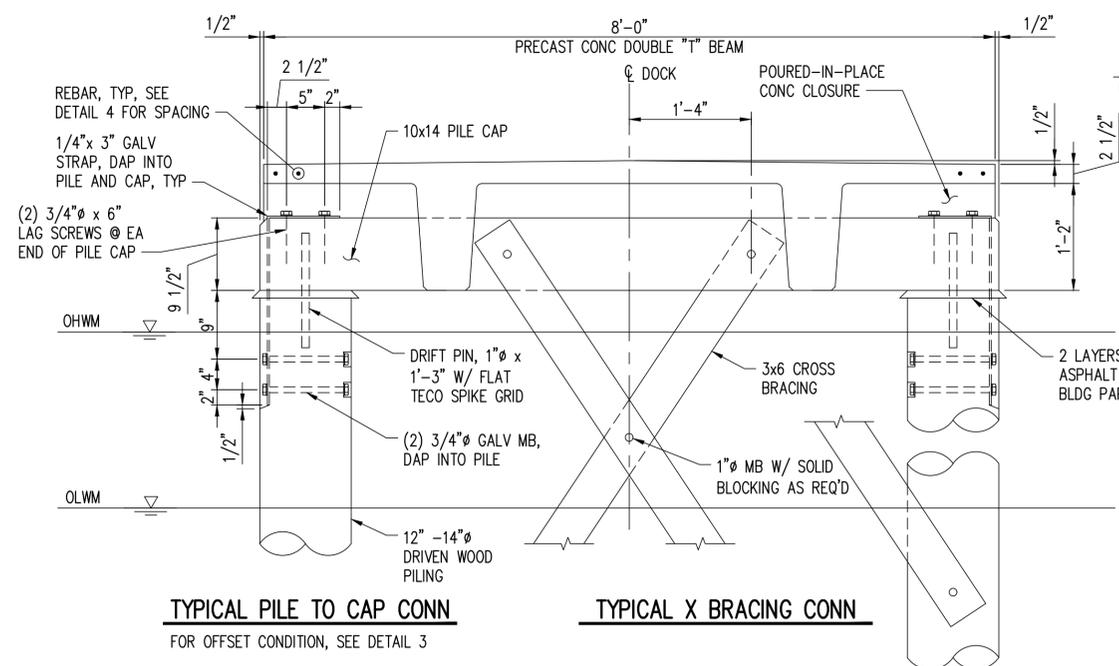

TYPICAL PILE TO CAP CONN
 FOR OFFSET CONDITION, SEE DETAIL 3

TYPICAL X BRACING CONN

TYPICAL CROSS SECTION/RIGID DOCK

SCALE: 1" = 1'-0"

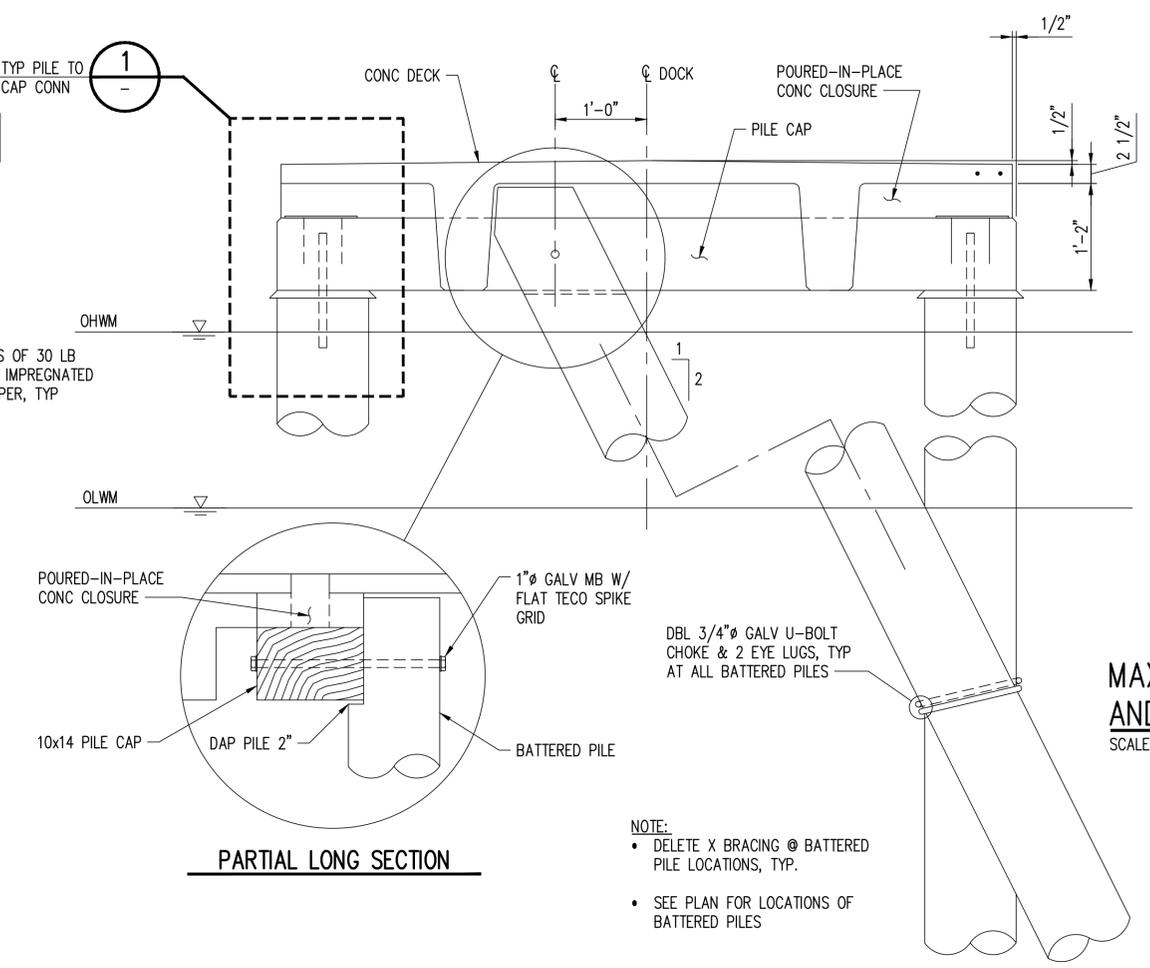

PARTIAL LONG SECTION

TYPICAL CROSS SECTION AT BATTERED PILES

SCALE: 1" = 1'-0"

- NOTE:**
- DELETE X BRACING @ BATTERED PILE LOCATIONS, TYP.
 - SEE PLAN FOR LOCATIONS OF BATTERED PILES

NOTES:

- CONTRACTOR SHALL VERIFY ALL EXISTING CONDITIONS IN THE FIELD PRIOR TO STARTING THE WORK. BRING ANY DISCREPANCIES TO THE ATTENTION OF THE ENGINEER.

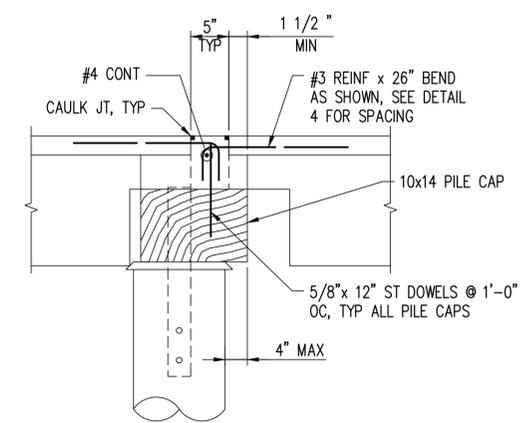

MAXIMUM PILE OFFSET, REINFORCING AND MINIMUM BEARING CRITERIA

SCALE: 1" = 1'-0"

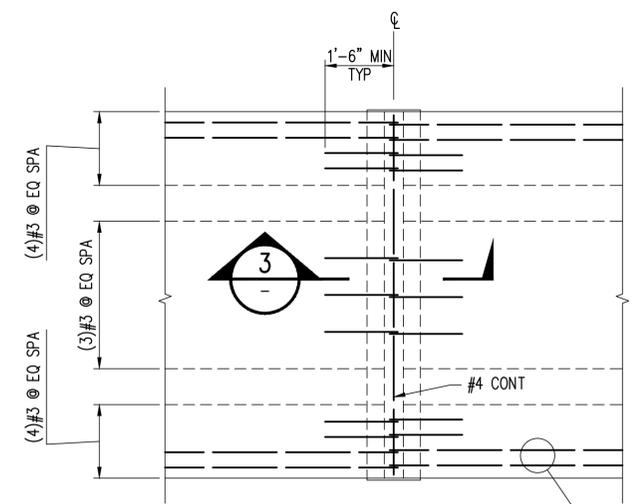

TYPICAL DOCK CONN REINFORCING PLAN

SCALE: 1/2" = 1'-0"

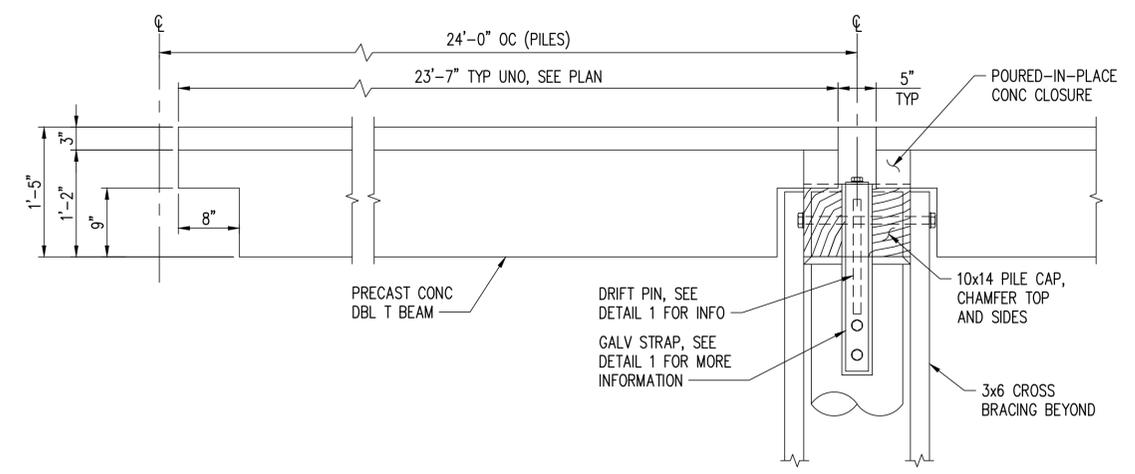

TYPICAL RIGID DOCK CONN/ELEVATION

SCALE: 1" = 1'-0"

NOTE: ALL INFORMATION ON THIS SHEET SHOWS EXISTING CONDITIONS AND WAS TAKEN FROM RECORD DRAWINGS FROM PREVIOUS PROJECTS. IT IS SHOWN FOR CONTRACTOR INFORMATION ONLY.

CAD USER: RICKT PLOT DATE: Apr 12, 2023-03:07pm
 PATH: V:\2000291 (Luther Burbank Pier Repairs)\02_Design (v2019)\LBPR_S-030.dwg

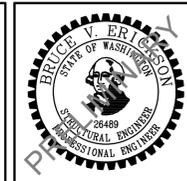

NO.	DATE	BY	REVISION
1A	4/14/2023	WBC	MIFD COMMENT REVISION



**LUTHER BURBANK PARK
 WATERFRONT IMPROVEMENTS**

FIXED PIER EXISTING CONDITIONS 1

DRAWN: RRT	PROJECT NO.: 2200248
DESIGN: WBC	SCALE: AS SHOWN
CHECKED: AKB	DATE: 10/7/2022
DRAWING NO.	S-030
SHEET NO.	49 OF 56

60% SUBMITTAL

NOTES:

- SEE DRAWING S-030 FOR ADDITIONAL NOTES.
- EXISTING CONDITION REPAIR SHOWN IN DETAIL 4, COMPLETED 2022.

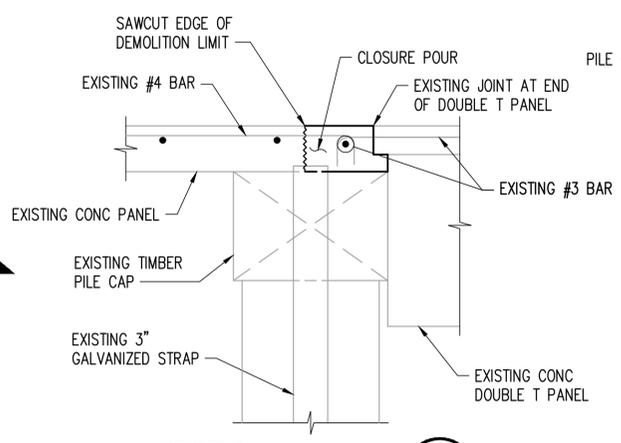
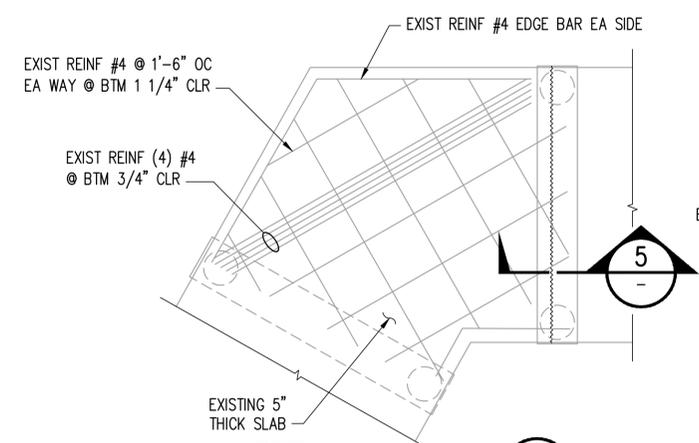
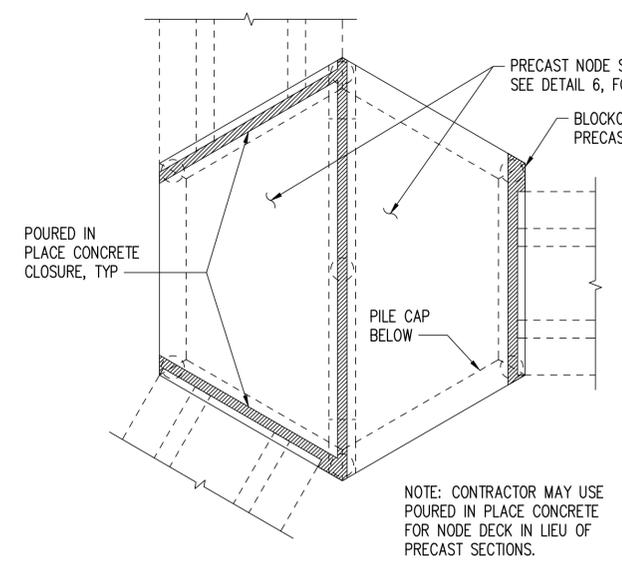
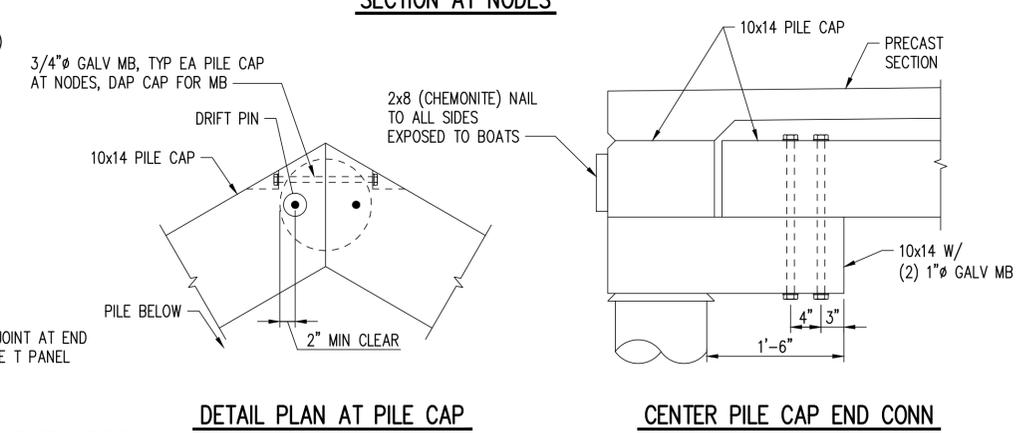
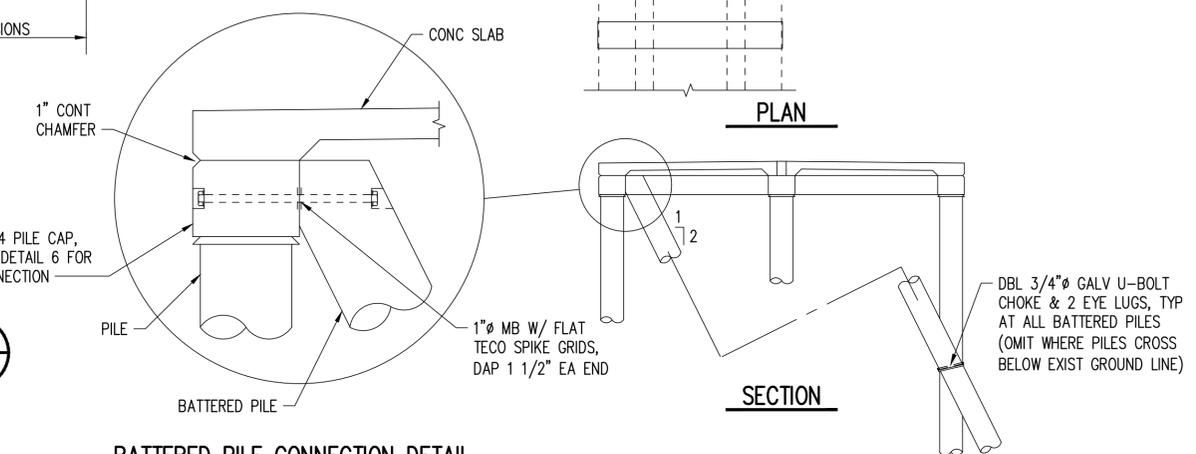
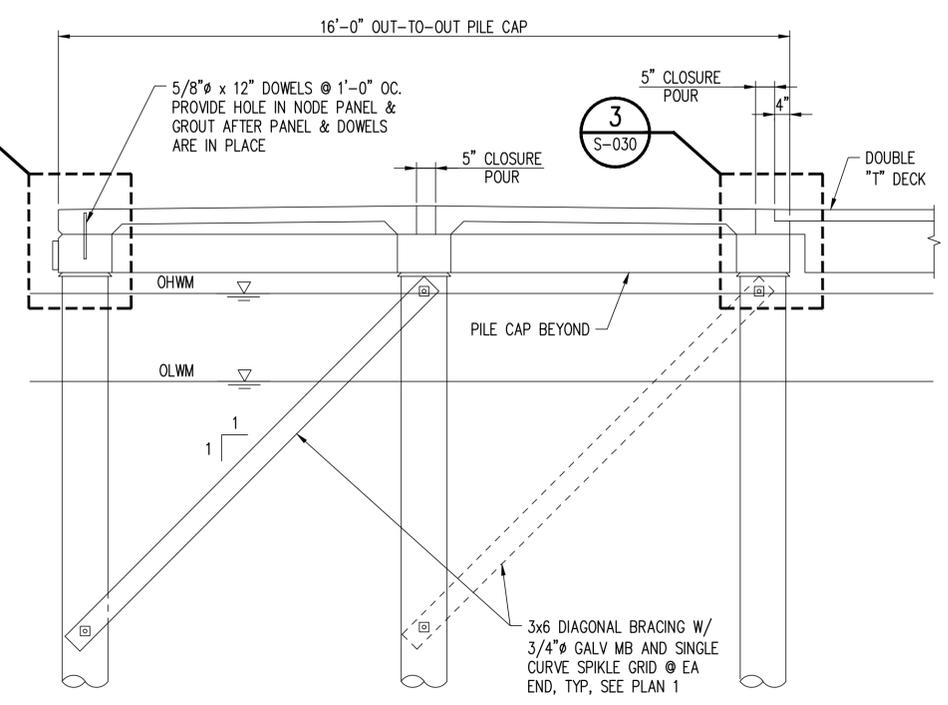
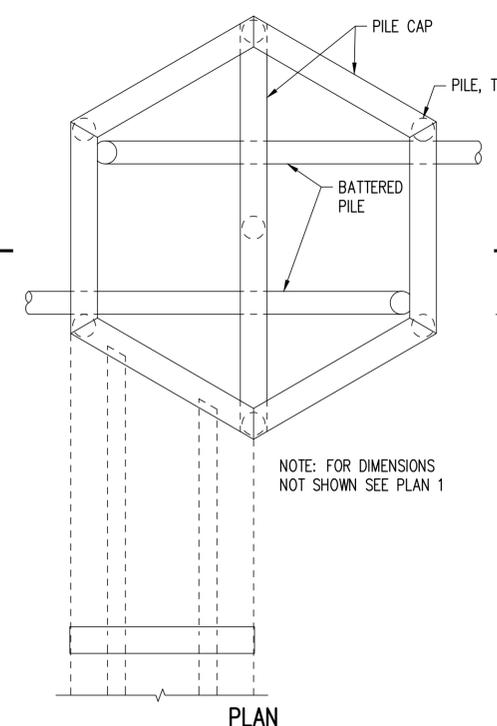
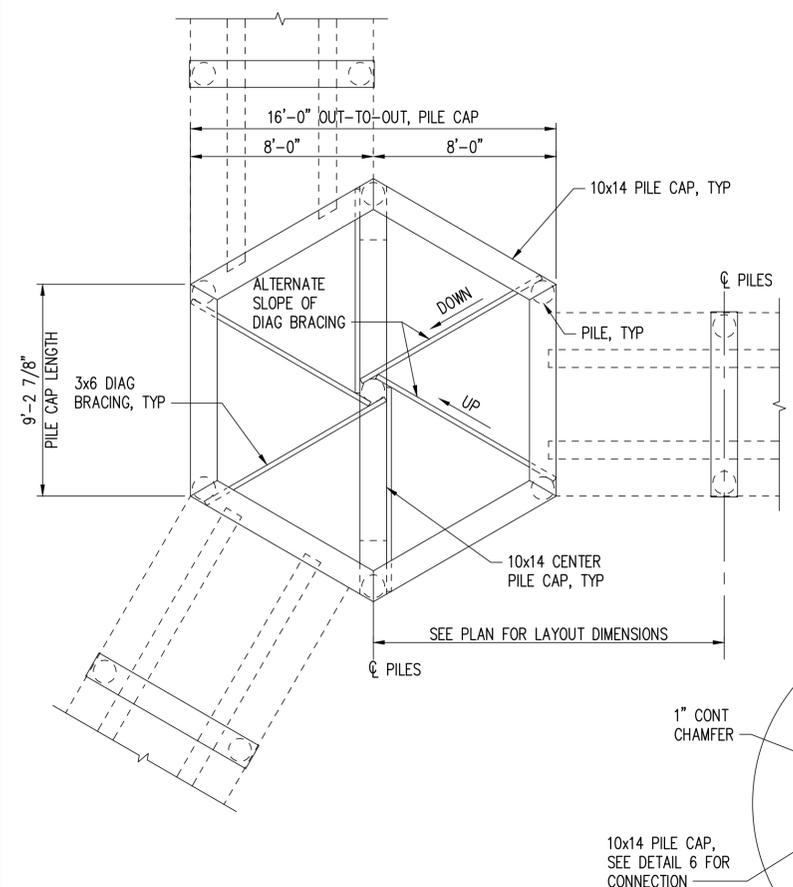

NOTE: ALL INFORMATION ON THIS SHEET SHOWS EXISTING CONDITIONS AND WAS TAKEN FROM RECORD DRAWINGS FROM PREVIOUS PROJECTS. IT IS SHOWN FOR CONTRACTOR INFORMATION ONLY.

CAD USER: RICKT PLOT DATE: Apr 12, 2023-03:08pm
PATH: V:\2000291 (Luther Burbank Pier Repairs)\02_Design (v2019)\LBPR_S-031.dwg

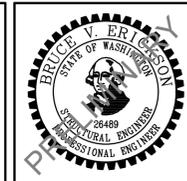

NO.	DATE	BY	REVISION
1A	4/14/2023	WBC	MIFD COMMENT REVISION



**LUTHER BURBANK PARK
WATERFRONT IMPROVEMENTS**

FIXED PIER EXISTING CONDITIONS 2

DRAWN: RRT	PROJECT NO.: 2200248
DESIGN: WBC	SCALE: AS SHOWN
CHECKED: AKB	DATE: 10/7/2022
DRAWING NO.	S-031
SHEET NO.	50 OF 56

60% SUBMITTAL

NOTES:

- SEE DRAWING S-030 FOR ADDITIONAL NOTES.
- EXISTING CONDITION TEMPORARY REPAIR SHOWN IN SECTION DETAIL 1 COMPLETED 2022.

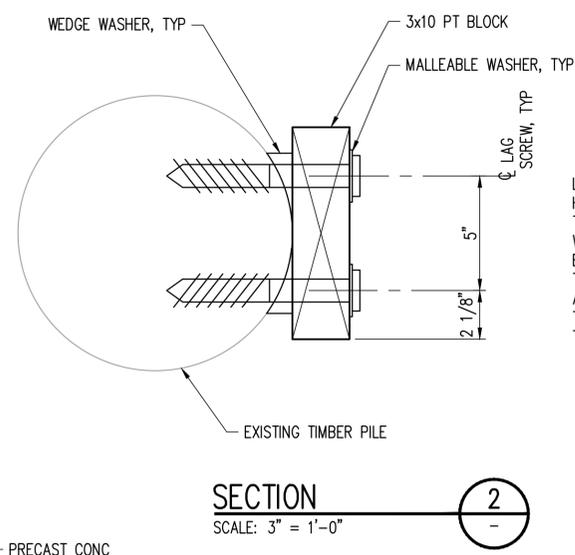
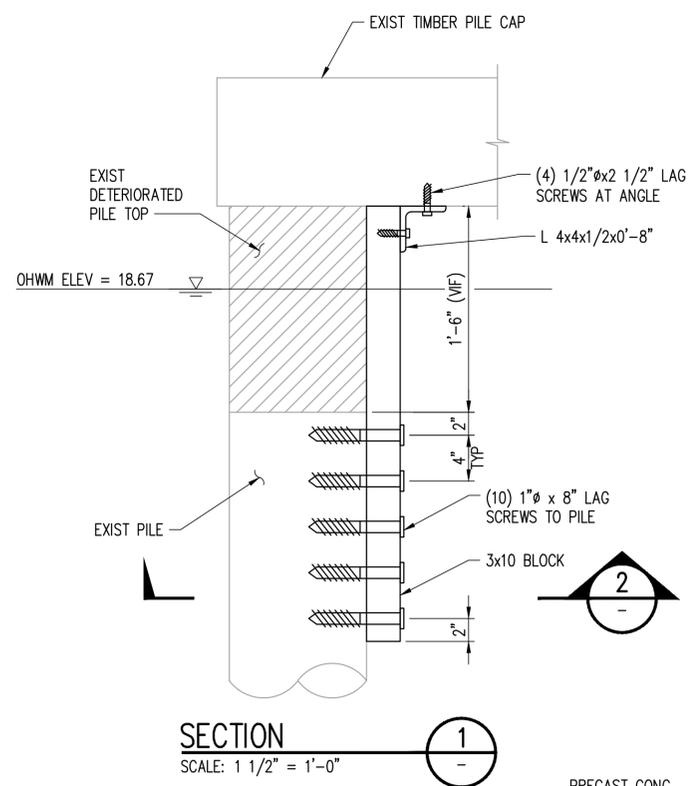

LAG SCREWS SHALL BE INSTALLED SNUG TIGHT, HOWEVER SHALL NOT INDUCE BENDING OF TIMBER BLOCKS. CONTRACTOR MAY FABRICATE WEDGE WASHERS TO ENSURE BLOCKS ARE NOT BENT. ANY BLOCK THAT IS BENT FROM OVER TIGHTENING LAG SCREWS SHALL BE REPLACED AT NO ADDITIONAL COST TO THE CITY. BLOCKS THAT ARE BENT WILL LIKELY BE SPLIT ALONG THE GRAIN OF THE BLOCKS.

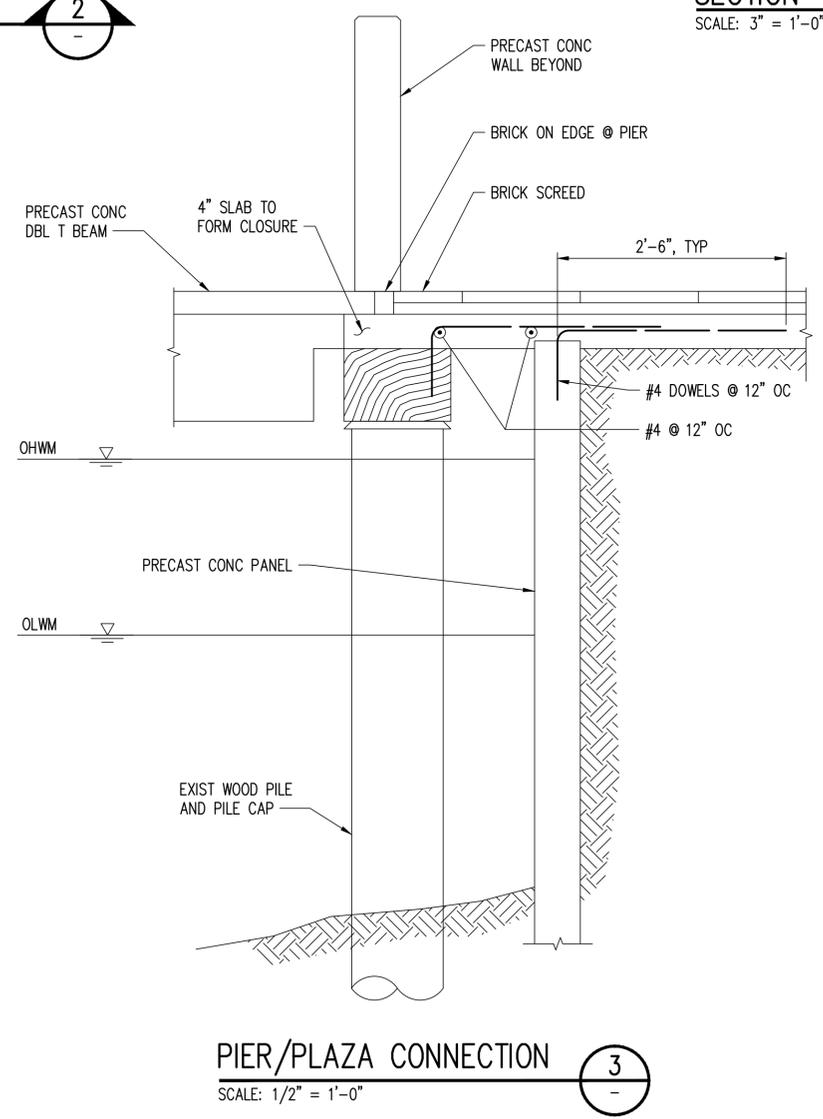

NOTE: ALL INFORMATION ON THIS SHEET SHOWS EXISTING CONDITIONS AND WAS TAKEN FROM RECORD DRAWINGS FROM PREVIOUS PROJECTS. IT IS SHOWN FOR CONTRACTOR INFORMATION ONLY.

CAD USER: RICKT PLOT DATE: Apr 12, 2023-03:10pm
 PATH: V:\2000291 (Luther Burbank Pier Repairs)\02_Design (v2019)\LBPR_S-032.dwg

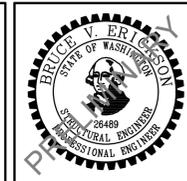

NO.	DATE	BY	REVISION
1A	4/14/2023	WBC	MIFD COMMENT REVISION



LUTHER BURBANK PARK
 WATERFRONT IMPROVEMENTS

FIXED PIER EXISTING CONDITIONS 3

DRAWN: RRT	PROJECT NO.: 2200248
DESIGN: WBC	SCALE: AS SHOWN
CHECKED: AKB	DATE: 10/7/2022
DRAWING NO.	S-032
SHEET NO.	51 OF 56

60% SUBMITTAL

NOTES:

- SEE DRAWINGS S-030 THRU S-032 FOR EXISTING CONDITIONS.
- EXTRACT DECAYED PILE CAPS FULL LENGTH WITHOUT DAMAGING EXISTING CONC DECK AND TIMBER PILES, AND REPLACE WITH TREATED 10x14 TIMBERS. REPLACE CONNECTING HARDWARE SHOWN IN EXISTING CONDITIONS UNO.

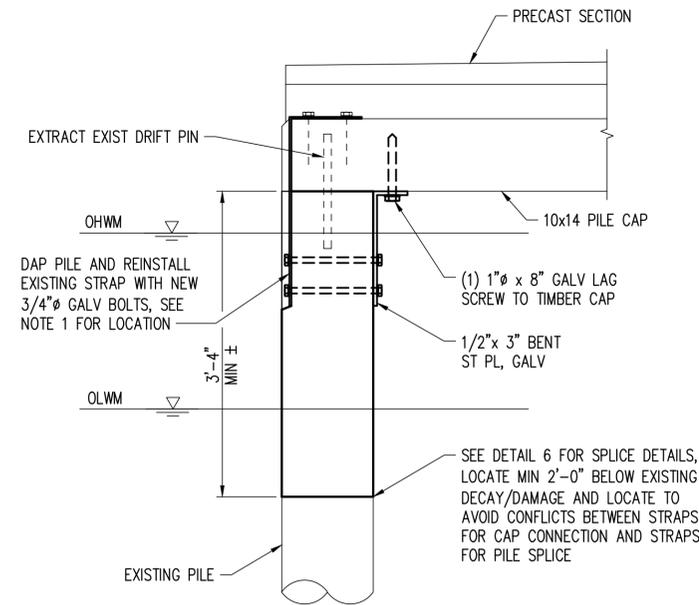

SECTION 1
SCALE: 1" = 1'-0"

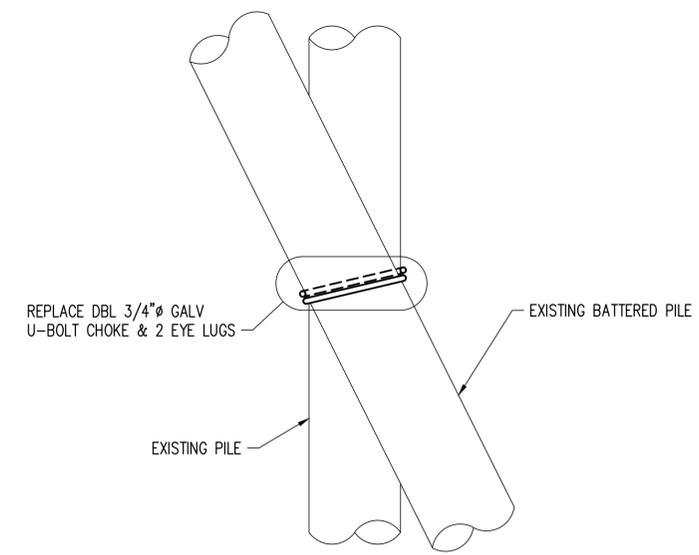

SECTION 2
SCALE: 1" = 1'-0"

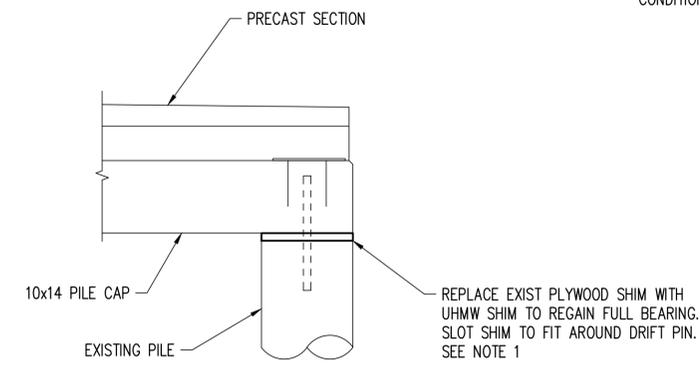

SECTION 3
SCALE: 1" = 1'-0"

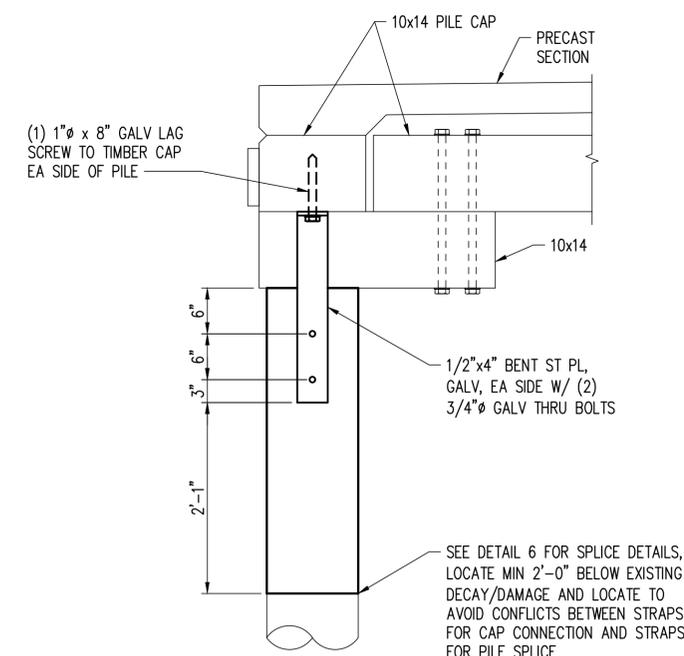

SECTION 4
SCALE: 1" = 1'-0"
S-041

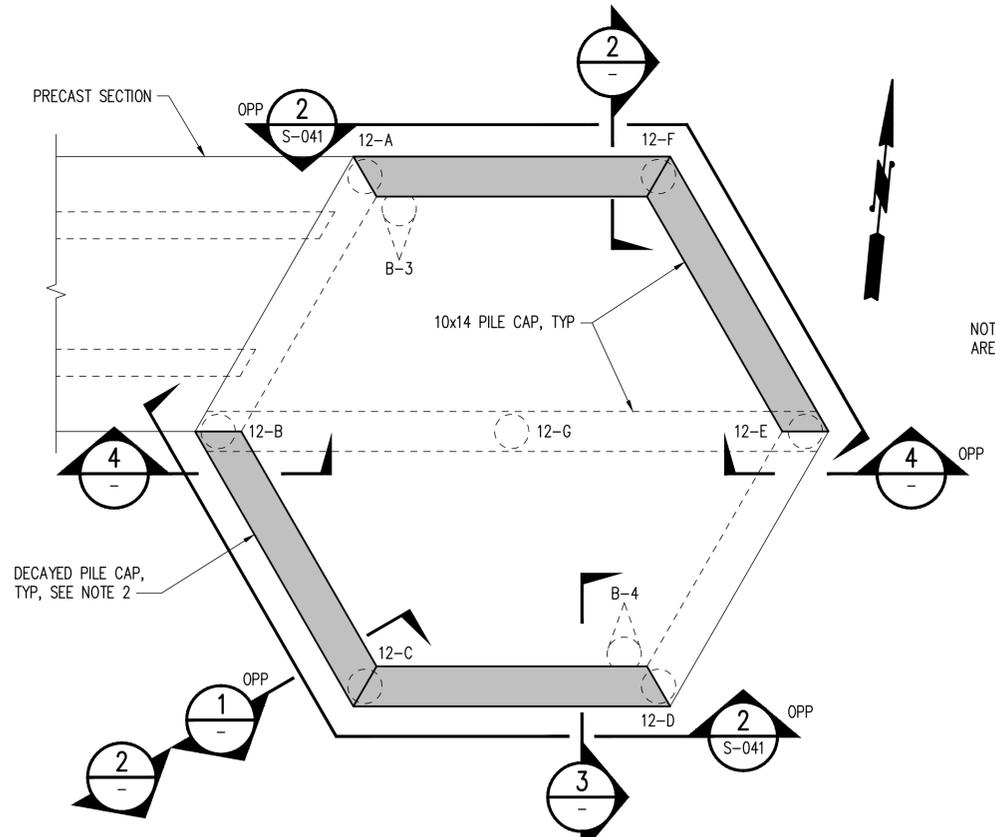

DETAIL 5
SCALE: 3/8" = 1'-0"
S-011

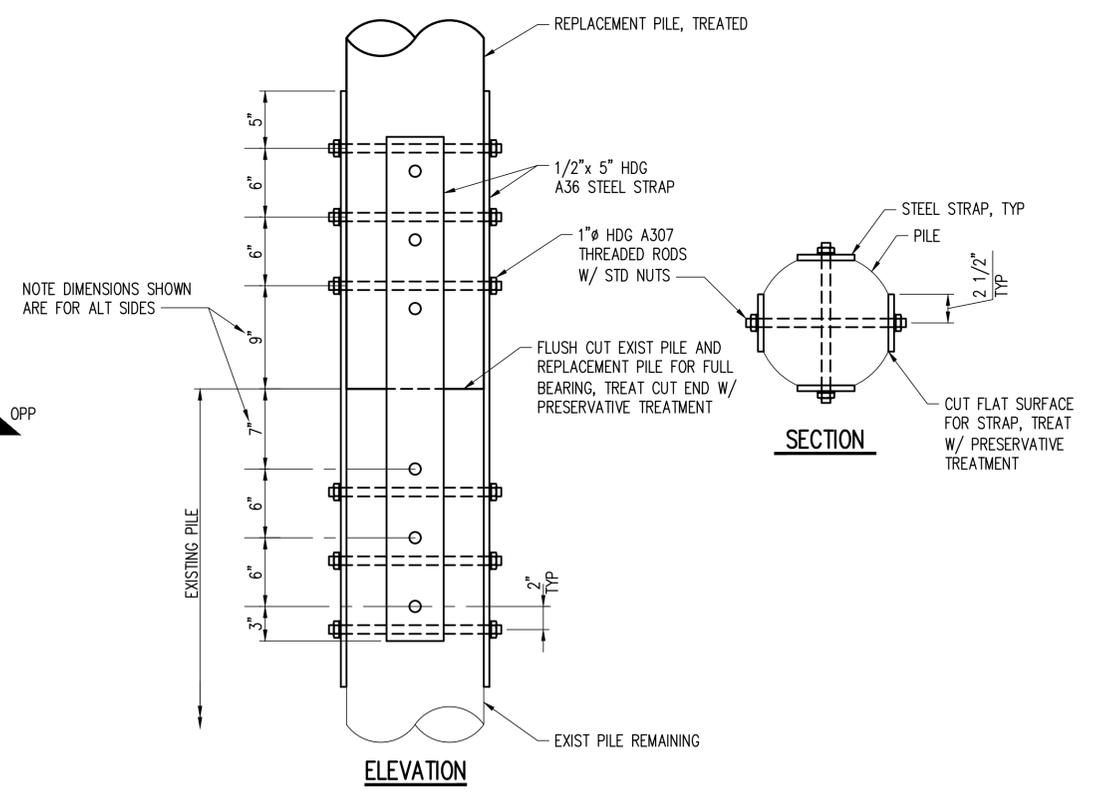

DETAIL 6
SCALE: 1 1/2" = 1'-0"

CAD USER: RICKT PLOT DATE: Apr 12, 2023-03:11pm
PATH: V:\2000291 (Luther Burbank Pier Repairs)\02_Design (v2019)\LBPR_S-040.dwg

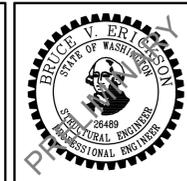

NO.	DATE	BY	REVISION
1A	4/14/2023	WBC	MIFD COMMENT REVISION



**LUTHER BURBANK PARK
WATERFRONT IMPROVEMENTS**

FIXED PIER REPAIR DETAILS

DRAWN: RRT	PROJECT NO.: 2200248
DESIGN: WBC	SCALE: AS SHOWN
CHECKED: AKB	DATE: 10/7/2022
DRAWING NO.	S-040
SHEET NO.	52 OF 56

60% SUBMITTAL

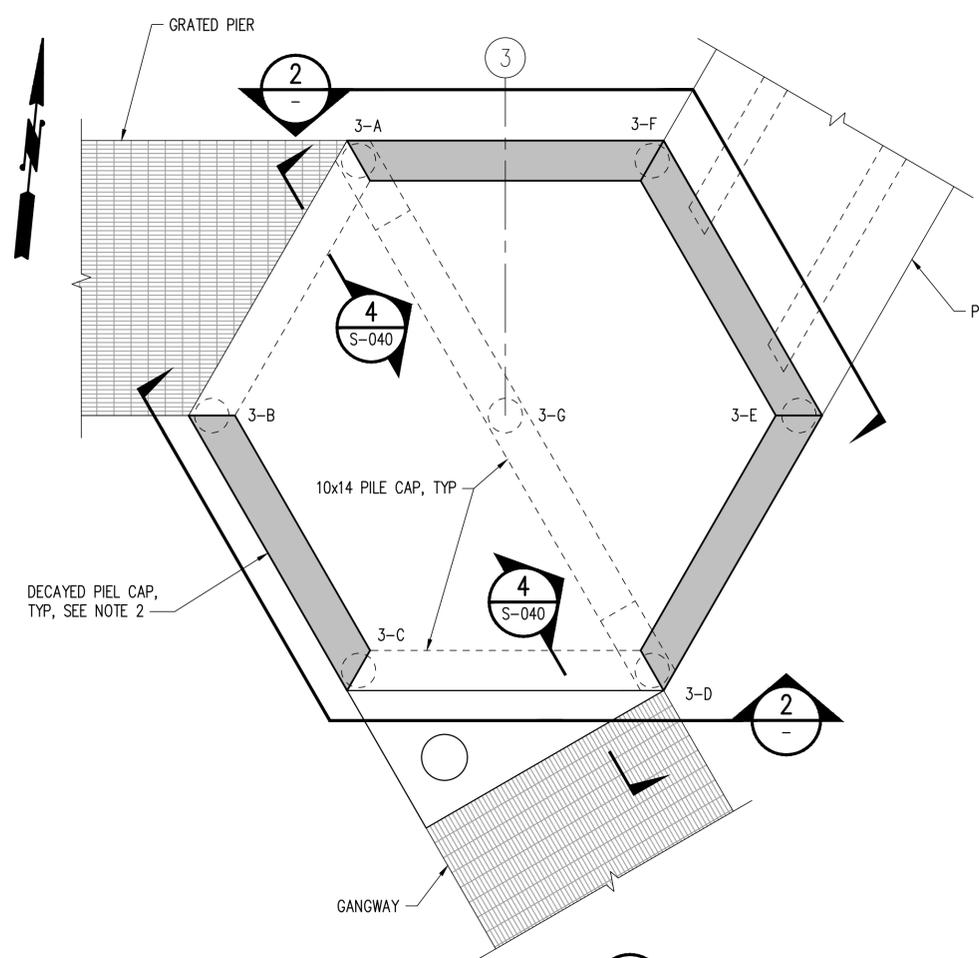

DETAIL
SCALE: 3/8" = 1'-0"
1

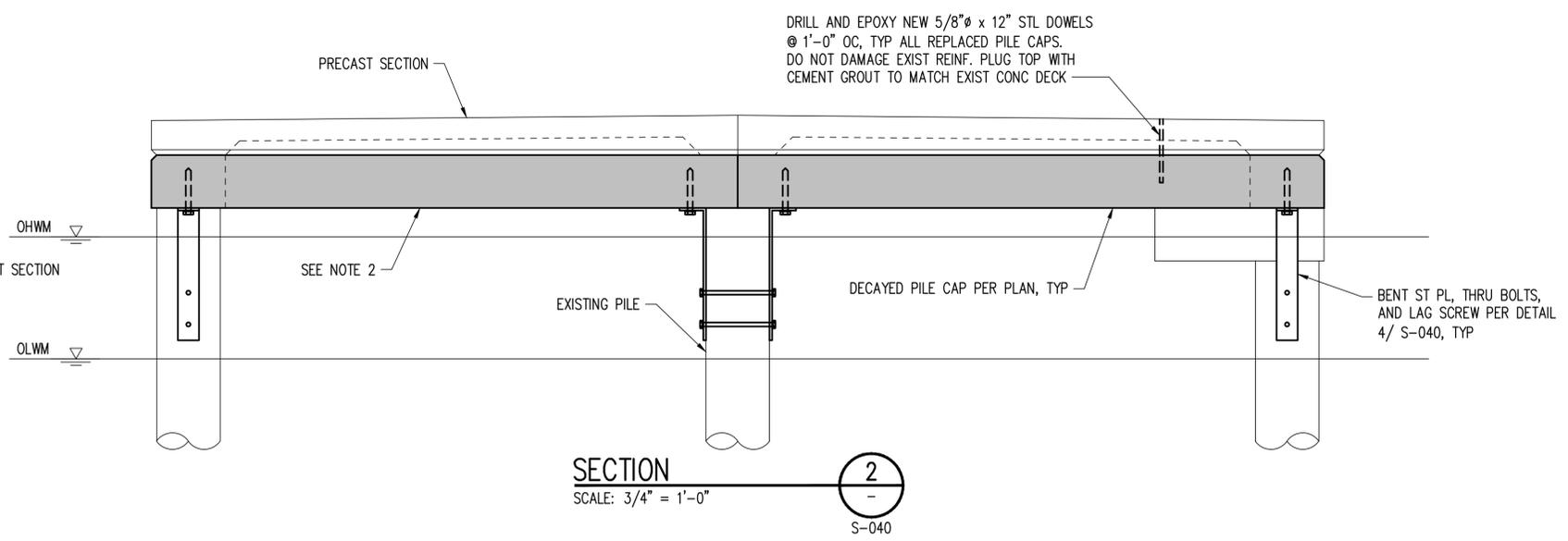

SECTION
SCALE: 3/4" = 1'-0"
2

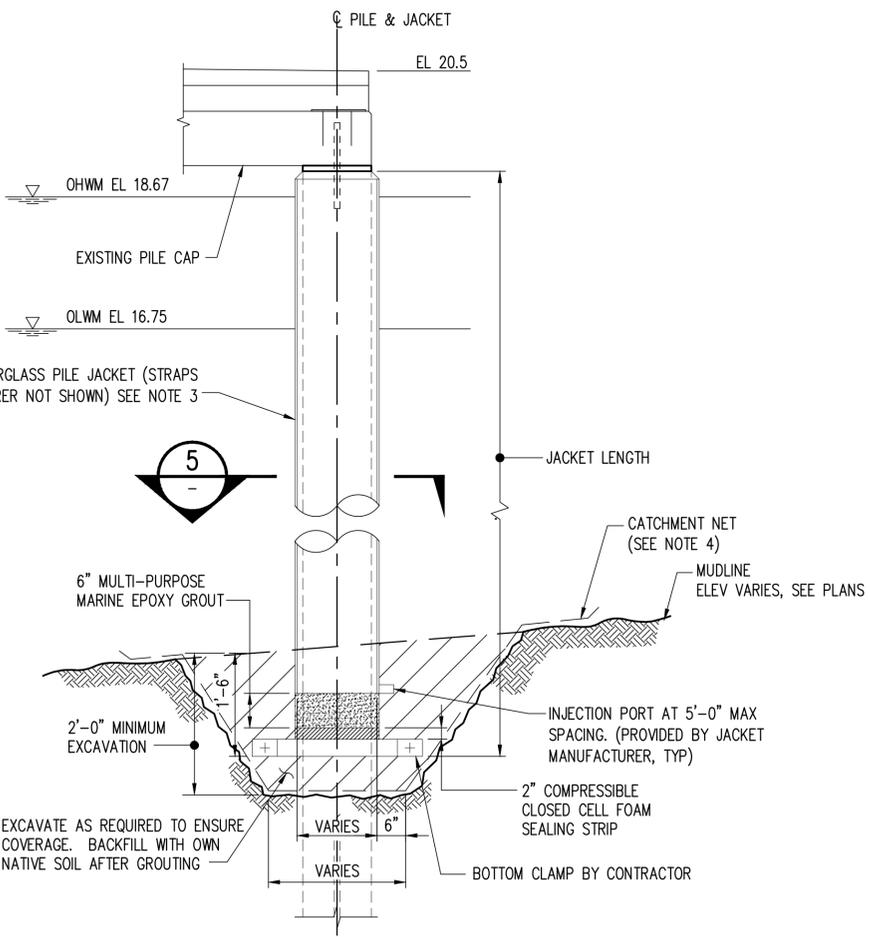

SECTION
SCALE: 3/4" = 1'-0"
4

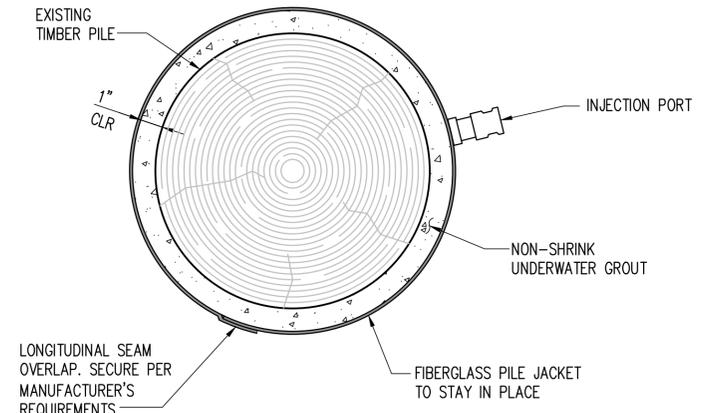

SECTION
SCALE: 3" = 1'-0"
5

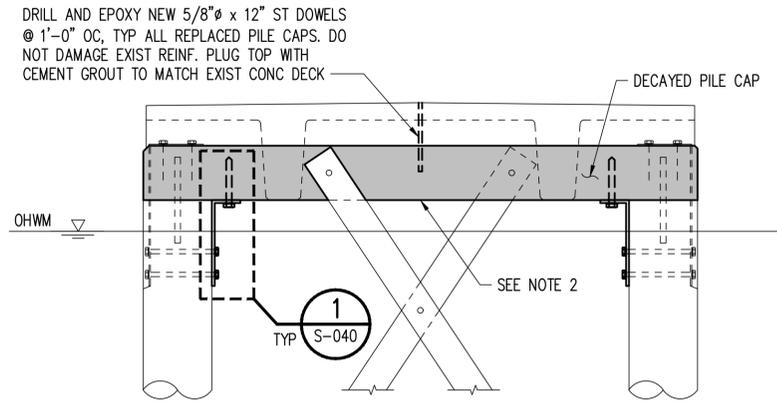

SECTION
SCALE: 3/4" = 1'-0"
3

- NOTES:**
- SEE DRAWINGS S-030 THRU S-032 FOR EXISTING CONDITIONS.
 - EXTRACT DECAYED PILE CAPS FULL LENGTH WITHOUT DAMAGING EXISTING CONC DECK AND TIMBER PILES, AND REPLACE WITH TREATED 10x14 TIMBERS. REPLACE CONNECTING HARDWARE SHOWN IN EXISTING CONDITIONS UNO.
 - PLACE JACKETS AROUND ALL (38) PILES, INCLUDING PILES REPAIRED PER DETAIL 6/S-040.

CAD USER: RICKT PLOT DATE: Apr 12, 2023-03:13pm
PATH: V:\2000291 (Luther Burbank Pier Repairs)\02_Design (v2019)\LBPR_S-041.dwg



1601 5th Avenue, Suite 1600
Seattle, WA 98101
206.622.5822
www.kpff.com

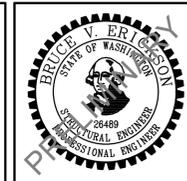

NO.	DATE	BY	REVISION
1A	4/14/2023	WBC	MIFD COMMENT REVISION



**LUTHER BURBANK PARK
WATERFRONT IMPROVEMENTS**

FIXED PIER REPAIR DETAILS

DRAWN: RRT	PROJECT NO.: 2200248
DESIGN: WBC	SCALE: AS SHOWN
CHECKED: AKB	DATE: 10/7/2022
DRAWING NO.	S-041
SHEET NO.	53 OF 56

60% SUBMITTAL

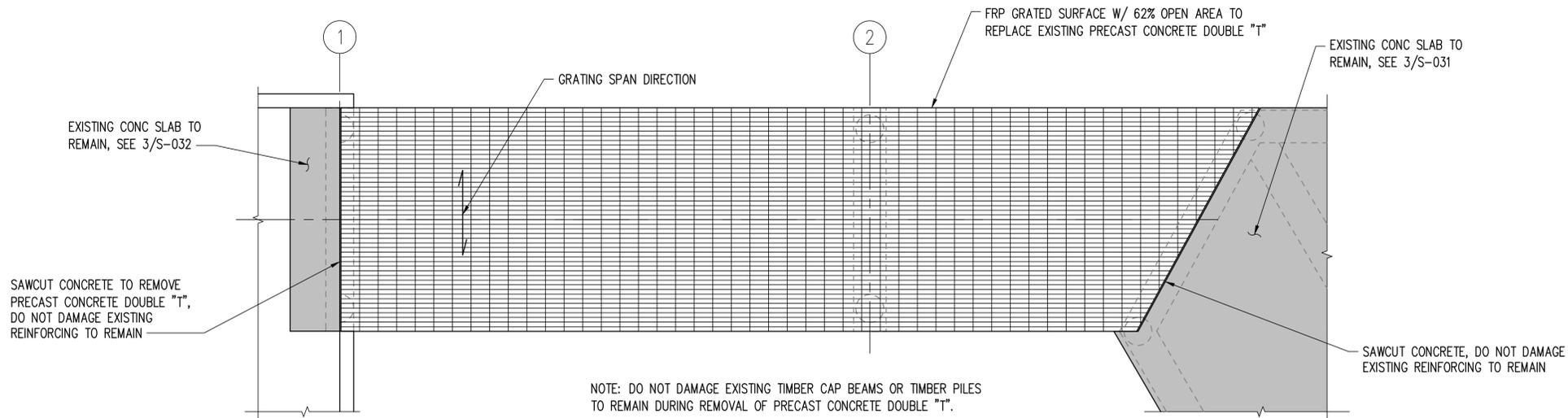

FINISH PLAN DETAIL 1
SCALE: 3/8" = 1'-0"

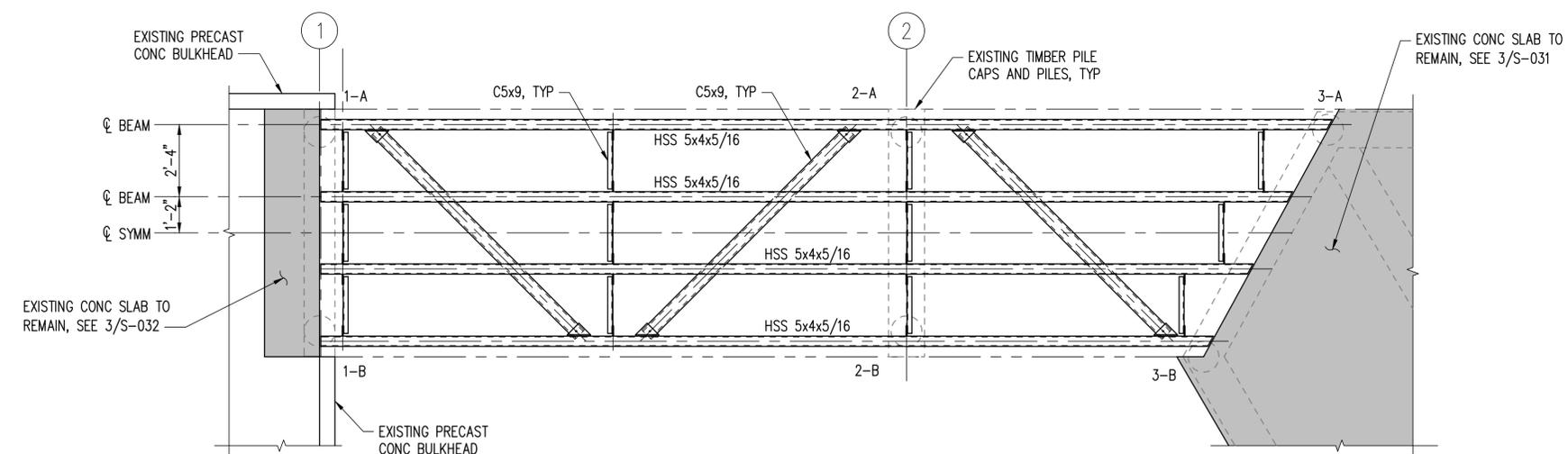

FRAMING PLAN DETAIL 2
SCALE: 3/8" = 1'-0"

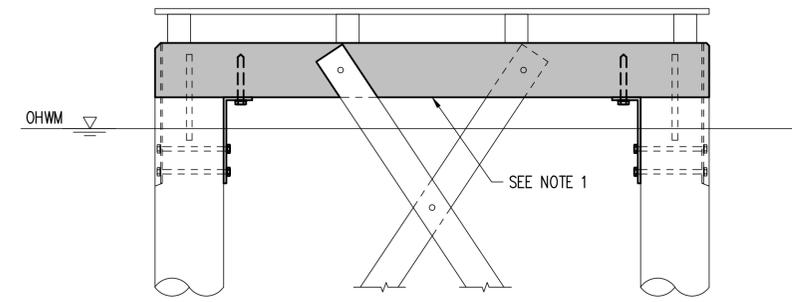

SECTION 3
SCALE: 3/4" = 1'-0"

NOTES:

1. EXTRACT DECAYED PILE CAP AT BENT 2 FULL LENGTH WITHOUT DAMAGING EXISTING TIMBER PILES. REPLACE WITH TREATED 10x14 TIMBER. REPLACE CONNECTING HARDWARE SHOWN IN EXISTING CONDITIONS UNO.

CAD USER: RICKT PLOT DATE: Apr 12, 2023-03:14pm
PATH: V:\2000291 (Luther Burbank Pier Repairs)\02_Design (v2019)\LBPR_S-042.dwg

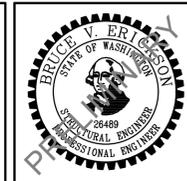

NO.	DATE	BY	REVISION
1A	4/14/2023	WBC	MIFD COMMENT REVISION



LUTHER BURBANK PARK
WATERFRONT IMPROVEMENTS

FIXED PIER GRATING DETAILS

DRAWN: RRT	PROJECT NO.: 2200248
DESIGN: WBC	SCALE: AS SHOWN
CHECKED: AKB	DATE: 10/7/2022
DRAWING NO.	S-042
SHEET NO.	54 OF 56

60% SUBMITTAL

NOTES:

- 40% MINIMUM LIGHT TRANSMISSION IS REQUIRED. SEE STRUCTURAL NOTES AND SPECIFICATIONS FOR MORE INFORMATION

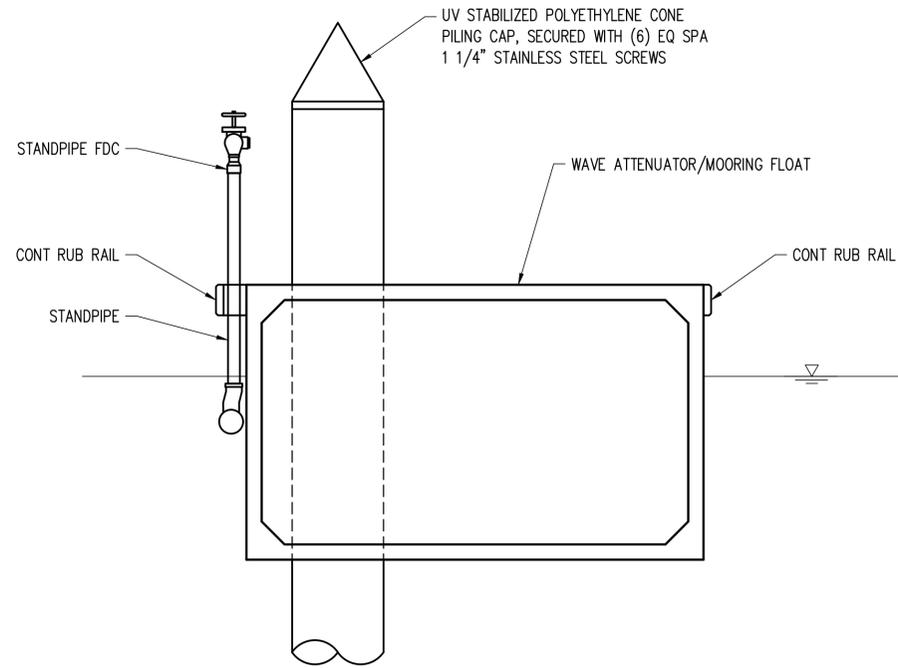

SECTION 1
SCALE: 1/2" = 1'-0"

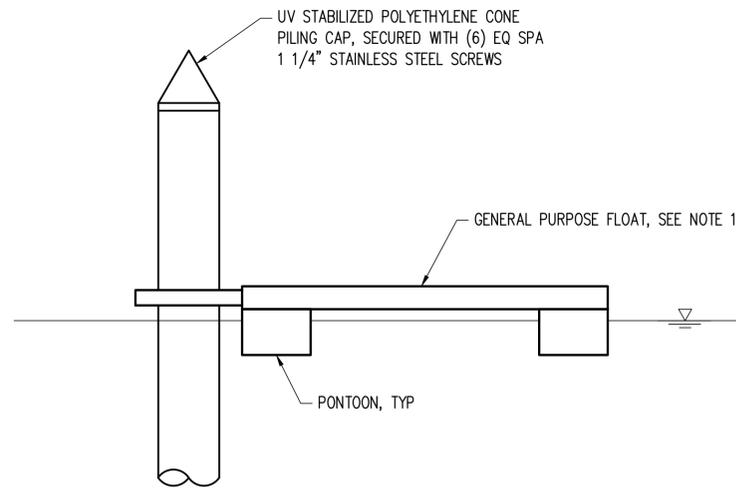

SECTION 2
SCALE: 1/2" = 1'-0"

PILE SCHEDULE						
Pile ID	Nominal Dia (in)	Wall t (in)	Cutoff Elev (ft)	Approx Mudline Elev (ft)	Embed (ft)	Tip Elev (ft)
1	16	0.625	20.00	9.00	20.00	-11.00
2	16	0.625	22.00	2.75	20.00	-17.25
3	16	0.625	22.00	-0.25	20.00	-20.25
4	16	0.625	22.00	-1.75	20.00	-21.75
5	16	0.625	22.00	-1.50	20.00	-21.50
6	16	0.625	22.00	-1.00	20.00	-21.00
7	16	0.625	20.00	5.50	20.00	-14.50
8	24	0.625	25.00	-7.50	28.00	-35.50
9	24	0.625	25.00	-10.75	28.00	-38.75
10	24	0.625	25.00	-13.00	28.00	-41.00
11	24	0.625	25.00	-16.00	28.00	-44.00
12	24	0.625	25.00	-16.50	28.00	-44.50
13	24	0.625	25.00	-16.25	28.00	-44.25
14	24	0.625	25.00	-16.25	28.00	-44.25
15	24	0.625	25.00	-16.25	28.00	-44.25
16	24	0.625	25.00	-16.25	28.00	-44.25
17	24	0.625	25.00	-16.00	28.00	-44.00
18	24	0.625	25.00	-15.75	28.00	-43.75
19	24	0.625	25.00	-15.50	28.00	-43.50
20	24	0.625	25.00	-15.50	28.00	-43.50
21	24	0.625	25.00	-15.50	28.00	-43.50
22	24	0.625	25.00	-14.75	28.00	-42.75

CAD USER: RICKT PLOT DATE: Apr 12, 2023-03:14pm
PATH: V:\2000291 (Luther Burbank Pier Repairs)\02_Design (v2019)\LBPR_S-050.dwg

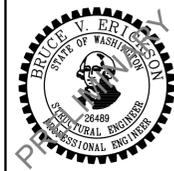

NO.	DATE	BY	REVISION
1	4/14/2023	WBC	LAND USE PERMIT REVISION
1A	4/14/2023	WBC	MIFD COMMENT REVISION



**LUTHER BURBANK PARK
WATERFRONT IMPROVEMENTS**

FLOAT DETAILS

DRAWN: RRT	PROJECT NO.: 2200248
DESIGN: WBC	SCALE: AS SHOWN
CHECKED: AKB	DATE: 10/7/2022
DRAWING NO.	S-050
SHEET NO.	55 OF 56

60% SUBMITTAL

NOTES:

- ELEVATIONS SHOWN ARE TOP OF GRATING SURFACE.
- FIBERGRATE AQUA GRATE T1210 OR APPROVED EQUAL, SPAN DIRECTION AS SHOWN.

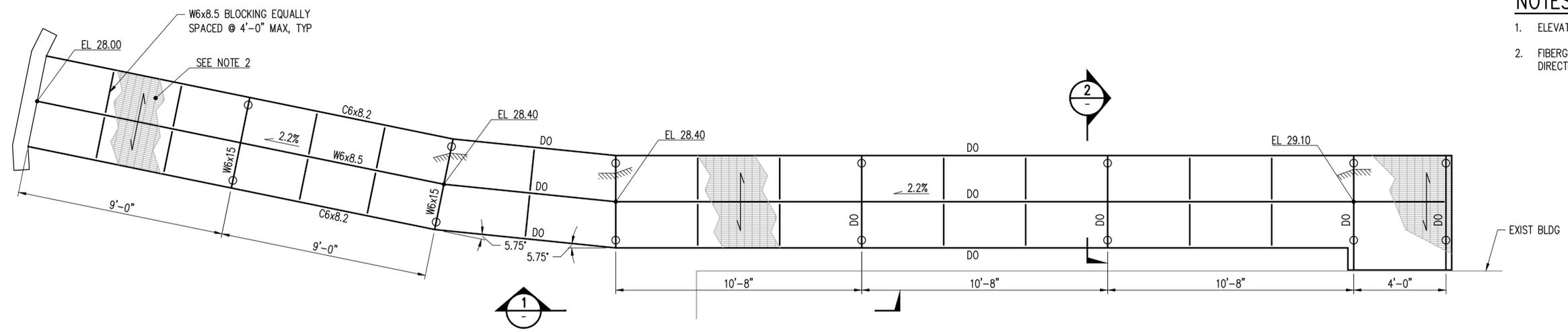

PLAN
SCALE: 3/8" = 1'-0"

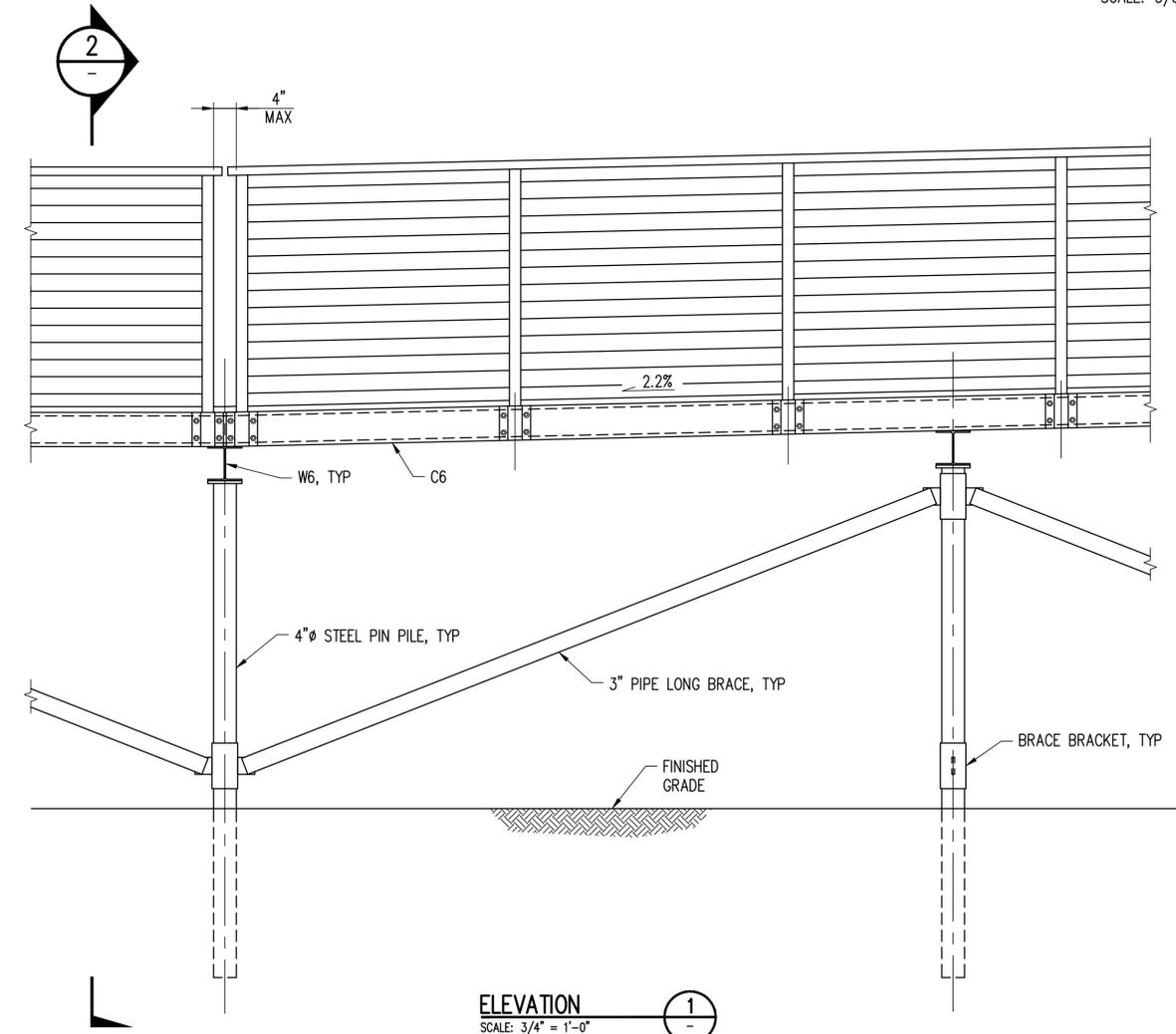

ELEVATION
SCALE: 3/4" = 1'-0"

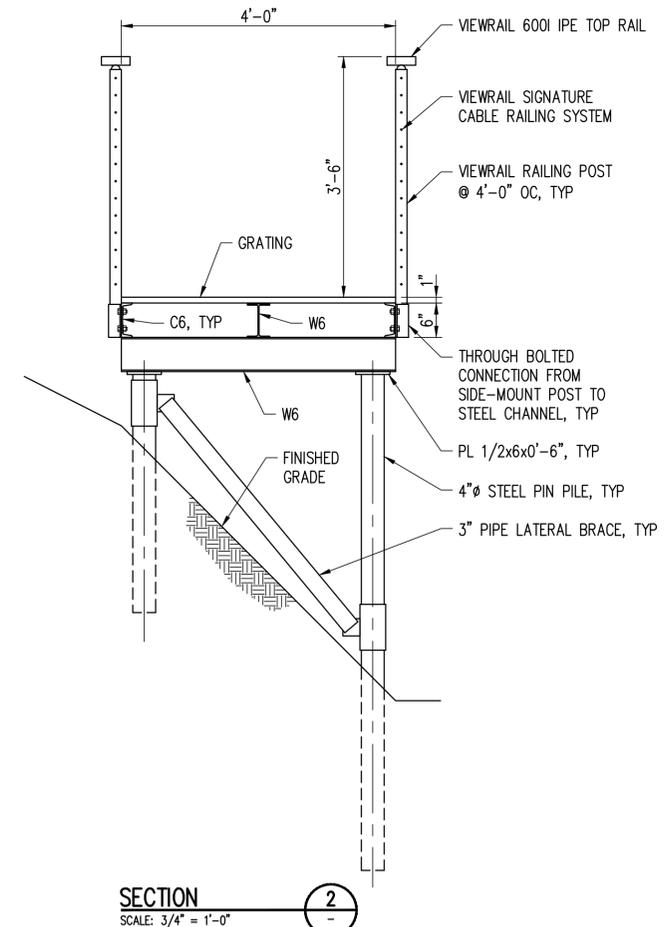

SECTION
SCALE: 3/4" = 1'-0"

CAD USER: RICKT PLOT DATE: Apr 12, 2023-03:17pm
PATH: V:\2000291 (Luther Burbank Pier Repairs)\02_Design (v2019)\LBPR_S-060.dwg

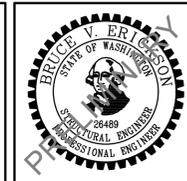

NO.	DATE	BY	REVISION
1	4/14/2023	WBC	LAND USE PERMIT REVISION
1A	4/14/2023	WBC	MIFD COMMENT REVISION



LUTHER BURBANK PARK
WATERFRONT IMPROVEMENTS

VIEWING DECK ELEVATED ACCESS PATH

DRAWN: RRT	PROJECT NO.: 2200248
DESIGN: WBC	SCALE: AS SHOWN
CHECKED: AKB	DATE: 10/7/2022
DRAWING NO.	S-060
SHEET NO.	56 OF 56

60% SUBMITTAL