

**PROJECT DESCRIPTION:**

REPLACE WORN WOODEN DECKING ON EXISTING RESIDENTIAL DOCK ON LAKE WASHINGTON WITH THRUFLOW GRATED PANELS. SOME OF THE STRUCTURAL FRAMING COMPONENTS MAY REQUIRE REPLACEMENT DURING THE DECK RESURFACING HOWEVER NO MORE THAN 50% OF THE DOCK FRAMING/SUBSTRUCTURE WILL BE REPLACED. SOME PILINGS MAY REQUIRE SLEEVING DURING THE REPAIR WORK HOWEVER NO MORE THAN 50% OF THE PILINGS WILL BE SLEEVED PER DETAIL ON PAGE 2. ALL WORK TO BE DONE IN EXISTING DOCK FOOTPRINT.

**LEGAL DESCRIPTION:**

FLOOD-DEARBORN ADD BEG AT INTSN OF E LN OF LOT 34 WITH LN 20 FT N & PLL WITH S LN OF LOT 34 TH N 00-08-31 W 70 FT TO S LN OF N 20 FT OF LOT 35 TH S 89-51-29 W ALG SD S LN 68 FT TAP S 89-51-29 W 123 FT FR ELY LN OF LOT 35 TH S 00-08-31 E 47 FT TH S 89-51-29 W 155 FT M/L TO SH LN OF LAKE WASH TH SLY ALG SD SH LN TO SW COR OF LOT 34 TH N 89-51-29 E 229 FT M/L TO SE COR OF LOT 34 TH NLY ALG ELY LN OF LOT 34 TO POB TGW 2ND CL SH LDS ADJ

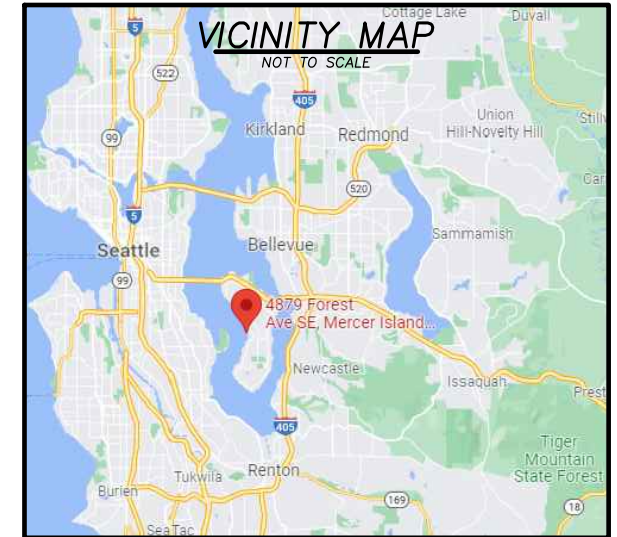
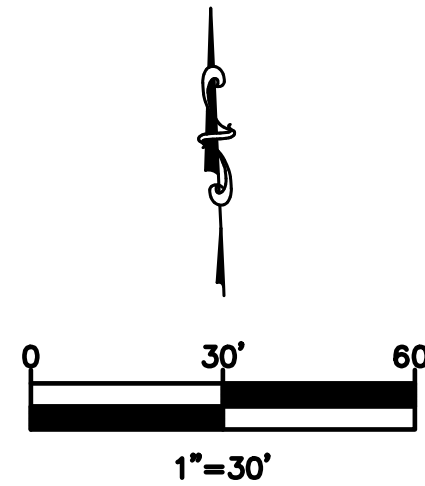

**PROPERTY OWNER:**

SCOTT ESKANAZI  
4879 FOREST AVE. SE  
MERCER ISLAND, WA 98040

**CONTACT:**

IRWIN LAND USE CONSULTING, LLC  
P.O. BOX 1715  
BELLINGHAM, WA 98227  
(360) 410-6745  
irwinlanduse@gmail.com

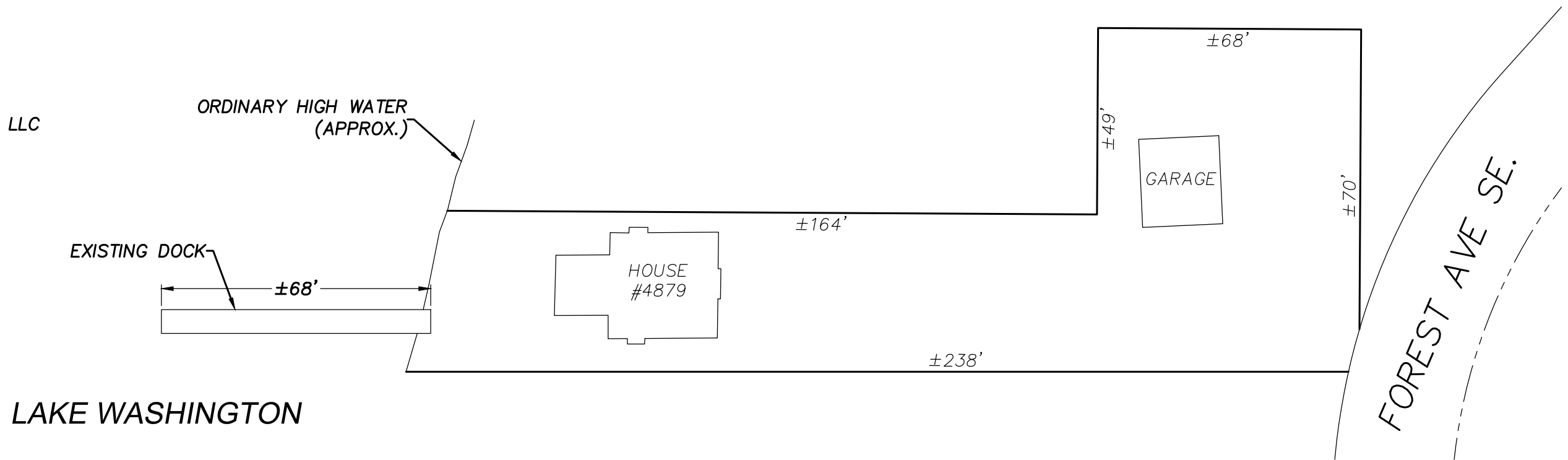

\*LOT BOUNDARIES AND BUILDING LOCATIONS PER M. W. MARSHALL SURVEY 10/93, AND KING COUNTY ASSESSOR GIS DATABASE. DOCK DIMENSIONS, PROJECT DESCRIPTION, AND WATER DEPTHS PER LAKESIDE CONSTRUCTION.



LAKESIDE CONSTRUCTION  
P.O. BOX 525  
ISSAQUAH, WA 98027  
(206) 850-0250  
sales@lakesideseattle.com

REV	DATE	BY	DESCRIPTION

**ESKANAZI**  
**DOCK REPAIR**  
4879 FOREST AVE. SE  
MERCER ISLAND, WA

PROJECT NUMBER:	2204
PARCEL NUMBER:	2574900176
ISSUE DATE:	2/2/2022

**DOCK LAYOUT**  
SCALE: 1"=10'

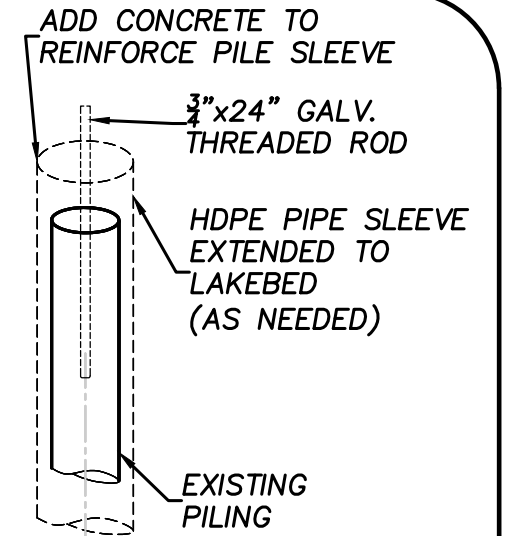
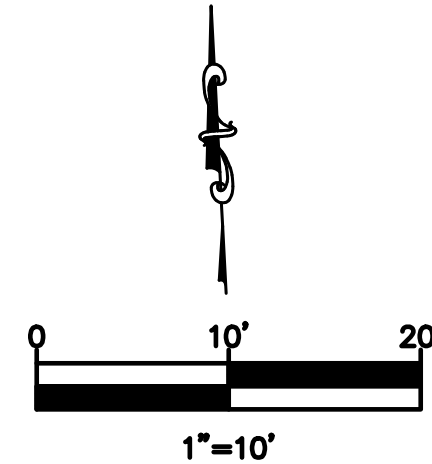
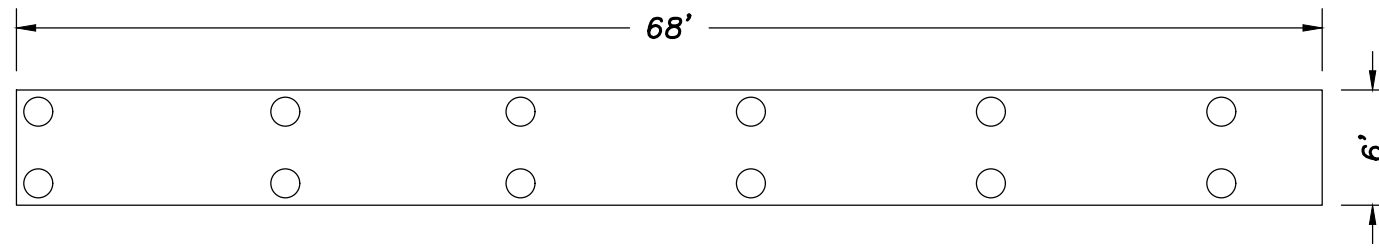

**PILE SLEEVING DETAIL**  
NTS  
SEE PIER END SECTION FOR CONNECTION DETAIL

**DOCK PROFILE**  
SCALE: 1"=10'

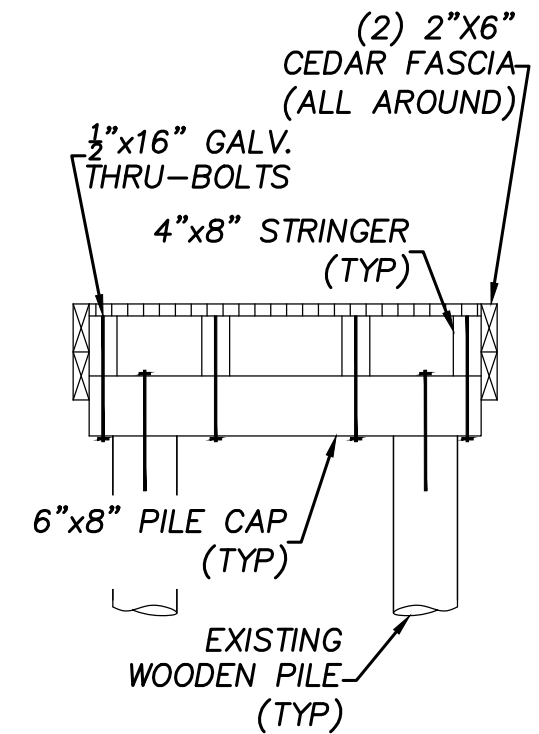
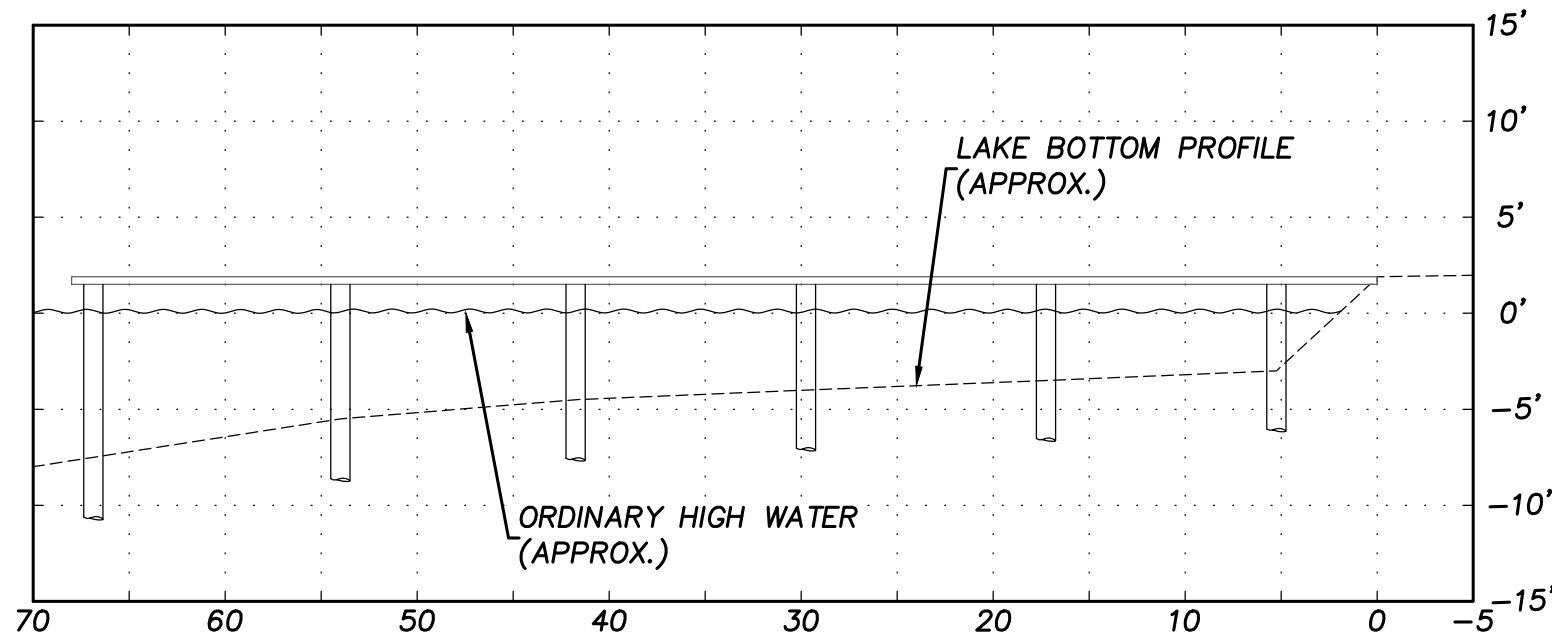

**PIER END SECTION**  
NTS



LAKESIDE CONSTRUCTION  
P.O. BOX 525  
ISSAQUAH, WA 98027  
(206) 850-0250  
sales@lakesideseattle.com

REV	DATE	BY	DESCRIPTION

**ESKANAZI**  
**DOCK REPAIR**  
4879 FOREST AVE. SE  
MERCER ISLAND, WA

PROJECT NUMBER:	2204
PARCEL NUMBER:	2574900176
ISSUE DATE:	2/2/2022