

# SITE PLAN

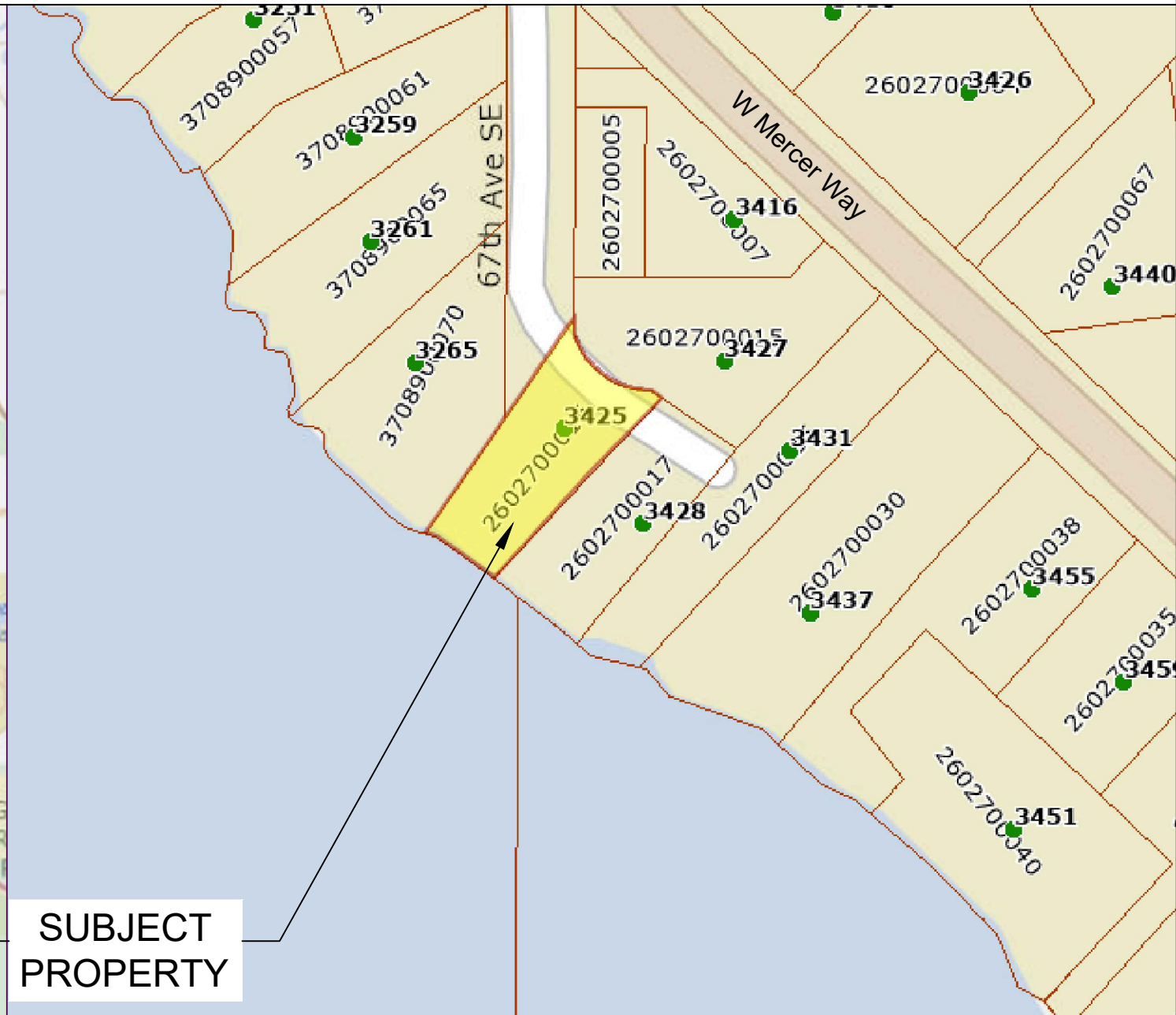
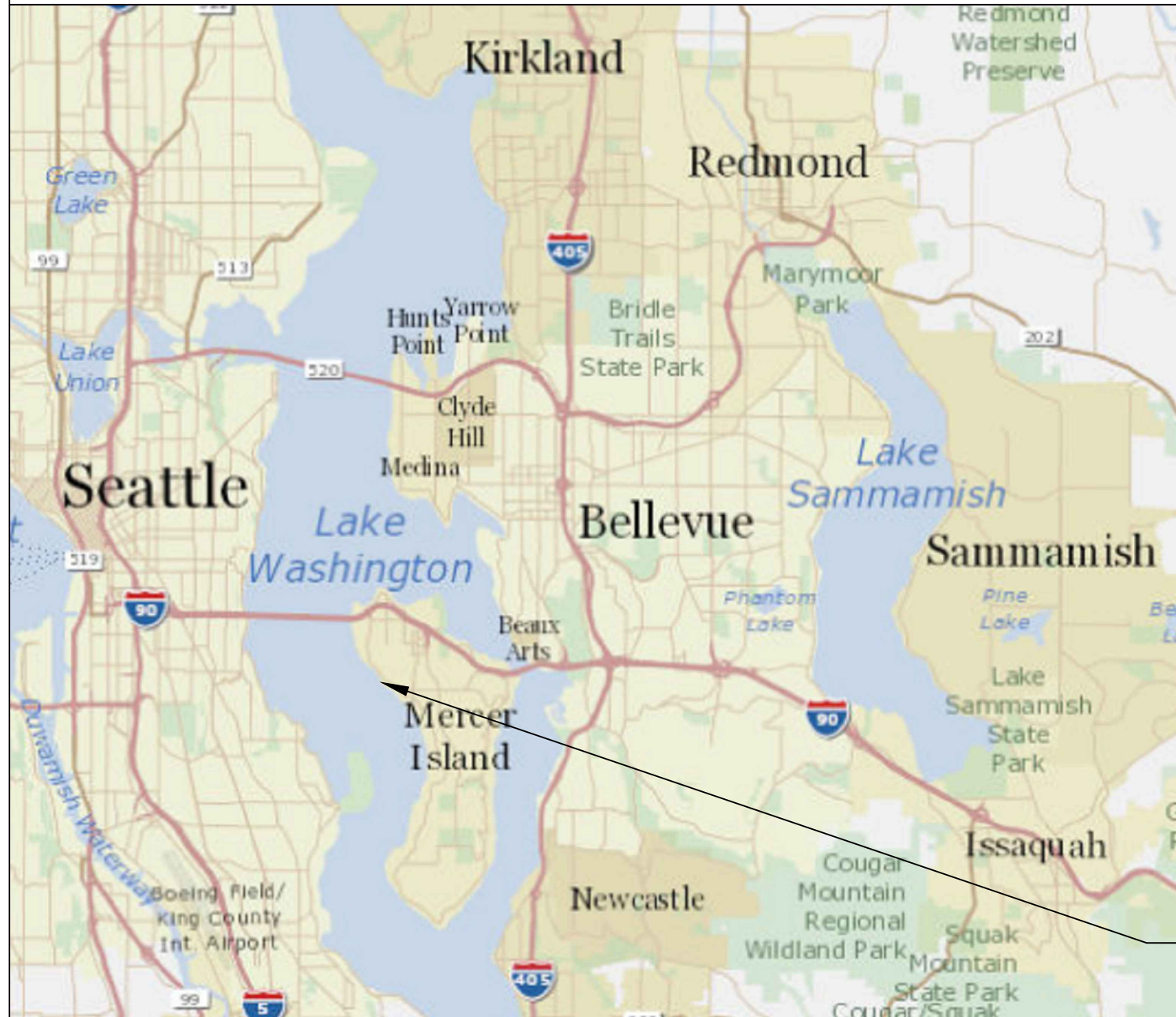

**SUBJECT  
PROPERTY**

Pin: 260270-0016  
 Legal Description: FORRESTS J T 1ST-E SEATTLE REPLAT POR 3 & NWLY 1/2 OF 4 SWLY OF LN BEG ON SELY LN OF SD NWLY 1/2 OF 4 AT PT 85.11 FT NELY FR MDR LN TH N 53 DEG 42 MIN 12 SEC W 68.90 FT TH ON CURVE TO RT 56.65 FT RAD BRG N 01 DEG 52 MIN 58 SEC W 73.09 FT TH NWLY TO PT ON W LN OF 3 AT PT 40.24 FT S OF NW COR & 2ND CL SH LDS ADJ & 2ND CL SH LDS OF SEC 11 SELY OF LN BRG S 41 DEG 33 MIN 00 SEC W FR PT ON MDR LN 16.33 FT NWLY OF SW COR OF SD 3 LESS C & M RGTS IN SEC 11 LESS POR THOF SLY OF LN BEG AT SLY TERMINUS OF SD CURVE & RNNG S 41 DEG 28 MIN 30 SEC W TO OUTER BNDRY LN OF SH LDS & POR VAC ST ADJ

Plat Block:  
 Plat Lot: 3-4

Parcel:  
 LAT: 47.57942  
 LONG: -122.24857

Dock:  
 LAT: 47.579261  
 LONG: -122.248858

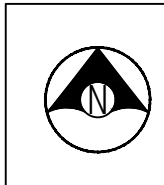

Seaborn Pile Driving  
 1080 W Ewing St  
 Seattle, WA 98119

Office: 206-236-1700 ext. 3  
[www.seabornpiledriving.com](http://www.seabornpiledriving.com)

Scope of Work: We propose to repair the existing dock and swim step with grated decking material, remove (1) existing boat lift with a canopy, and repair (11) existing piles.

Datum: CORPS OF ENGINEERS 1919  
 SW Quarter Of Section 12, Township 24, Range 04

Applicant: McMillan Residence  
 3425 67th Ave SE  
 Mercer Island, WA 98040

County: King County  
 Location: Lake Washington

Adjacent Owners:  
 AHRENS EDWARD D  
 3285 67TH AVE SE 98040

BEHAR RONALD+JAY-CO-TTEES  
 3428 67TH AVE SE 98040

Created: 04-04-23  
 Last Updated: 9/12/2023 11:36 AM Shop

**SHEET  
1.0**

NWS-2023-XXX  
 PAGE 1 OF 10

# GENERAL NOTES:

MATERIALS SPEC LIST:

**Boat Lifts:** Aluminum w/ Canopy

- \* Existing Lift - 118" x 144"
- \* 236 sqft Canopy - 118" x 288"

**Decking Material:** FRPP - Fiberglass reinforced polypropylene

Open Area percentage:

- \* Surface - 43%
- \* 18" Dock Height - 61%

**Sewer:**

- \* All sewer is field verified by probing the lake bed manually during the allowed work windows for the area.

**Piles:**

- \* Repair piles are done as a sleeve method
- \* All Pile tops exposed will have a conical cap placed on top

**WAC:**

- \* WAC 1. SEPA Compliance: WAC 197-11-800(3) Repair and Maintenance activities, SHL Exemption: 173-27-40(b) Normal Maintenance and Repair

CODE REFERENCES: Mercer Island

**We are applying for the permit to be reviewed under the:**

“Development Standards for Replacement, Repair and Maintenance of Overwater Structures, Including Moorage Facilities” per MIMC 19.13050(F)(2).

2. Development Standards for Replacement, Repair and Maintenance of Overwater Structures, Including Moorage Facilities. The maintenance, repair and complete replacement of legally existing overwater structures is permitted; provided, that:

i. All permit requirements of federal and state agencies are met;

**The project is in review by CORPs and WDFW.**

ii. The area, width, or length of the structure is not increased, but may be decreased;

**The area, width or length will not be increased.**

iii. The height of any structure is not increased, but may be decreased; provided, that the height above

the OHWM may be increased as provided in subsection (F)(2)(ix)(b) of this section;

**The height of the structure will not be increased.**

iv. The location of any structure is not changed unless the applicant demonstrates to the director’s satisfaction that the proposed change in location results in: (A) a net gain in ecological function, and (B) a higher degree of conformity with the location standards for a new overwater structure;

**The location of the structure will not change.**

v. Piles shall not be treated with pentachlorophenol, creosote, CCA or comparably toxic compounds. If ammoniacal copper zinc arsenate (ACZA) pilings are proposed, the applicant shall meet all of the best management practices, including a post-treatment procedure, as outlined in the amended Best Management Practices of the Western Wood Preservers. All piling sizes are in nominal diameter;

**Piles shall not be treated with any of these materials. Pile sizing is in nominal diameter.**

vi. Any paint, stain or preservative applied to components of the overwater structure must be leach resistant, completely dried or cured prior to installation. Materials shall not be treated with pentochlorophenol, creosote, CCA or comparably toxic compounds;

**All paints will be leach resistant and cured prior to installation.**

vii. The applicant shall abide by the work windows for listed species established by the U.S. Army Corps of Engineers and Washington Fish and Wildlife;

**Construction date will be within established work windows.**

Disturbance of bank vegetation shall be limited to the minimum amount necessary to accomplish the project. Disturbed bank vegetation shall be replaced with native, locally adapted herbaceous and/or woody vegetation. Herbaceous plantings shall occur within 48 hours of the completion of construction. Woody vegetation components shall be planted in the fall or early winter, whichever occurs first. The applicant shall take appropriate measures to ensure revegetation success; The Mercer Island City Code is current through Ordinance 20C-13, passed June 16, 2020.Ch. 19.13 Shoreline Master Program | Mercer Island City Code Page 30 of 34

**Disturbance to vegetation will be minimized and all plantings will meet requirements.**

ix. Structural Repair. The structural repair, which may include replacement of framing elements, of moorage facilities that results in the repair of more than 50 percent of the structure’s framing elements within a five-year period shall comply with subsections (F)(2)(ix)(a) through (F)(2)(ix)(c) of this section. For this section, framing elements include, but are not limited to, stringers, piles, pile caps, and attachment brackets, as shown in Figure D:

**Project will repair fewer than 50% of structural members.**

a. One hundred percent of the decking area of the pier, dock, and any platform lifts must be fully grated with materials that allow a minimum of 40 percent light transmittance;

**Project will repair fewer than 50% of structural members.**

b. The height above the OHWM for moorage facilities, except floats, shall be a minimum of one and one-half feet and a maximum of five feet; and

**Project will repair fewer than 50% of structural members.**

c. An existing moorage facility that is five feet wide or more within 30 feet waterward from the OHWM shall be replaced or repaired with a moorage facility that complies with the width of moorage facilities standards specified in Table D of this section;

**Project will repair fewer than 50% of structural members.**

x. Exterior surface repair. The exterior surface repair, which may include the replacement of exterior surface materials of moorage facilities that results in the repair of more than 50 percent of the surface area of the moorage facility's decking, fascia, and platform lifts within a five-year period (see Figure D), shall be required to utilize materials that allow a minimum of 40 percent light transmittance over 100 percent of the dock; and

**Decking material will meet light transmittance requirements.**

xi. Any decking that is removed in the course of repair shall be replaced with decking materials that allow a minimum of 40 percent light transmittance.

**Replacement decking to exceed light transmittance requirements.**

Last permit issued for property: BLDG1807-285 07-30-2019

Dock established/constructed: 69-270 06-15-1967

County: King County  
Location: Lake Washington

Applicant: McMillan Residence  
3425 67th Ave SE  
Mercer Island, WA 98040

Datum: CORPS OF ENGINEERS 1919  
SW Quarter Of Section 12, Township 24, Range 04  
Adjacent Owners:  
AHRENS EDWARD D  
3285 67TH AVE SE 98040  
BEHAR RONALD+JAY-CO-TTEES  
3428 67TH AVE SE 98040

**SHEET**  
**2.0**



Seaborn Pile Driving  
1080 W Ewing St  
Seattle, WA 98119

Office: 206-236-1700 ext. 3  
www.seabornpiledriving.com

Scope of Work: We propose to repair the existing dock and swim step with grated decking material, remove (1) existing boat lift with a canopy, and repair (11) existing piles.

# EXISTING CONDITIONS

**\*\*CLEAN UP LAKE AROUND PROJECT\*\***

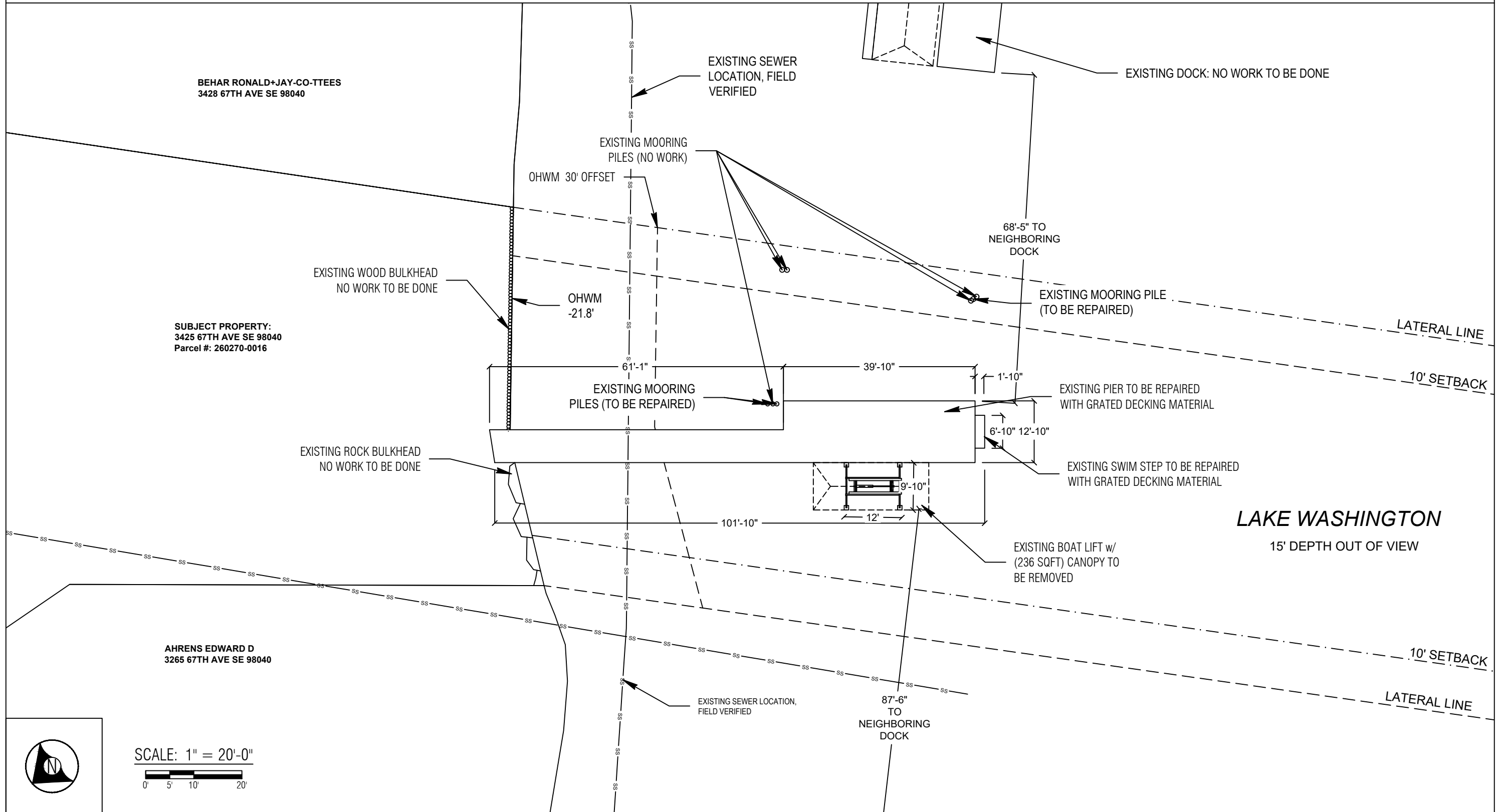

SCALE: 1" = 20'-0"  
0' 5' 10' 20'



Seaborn Pile Driving  
1080 W Ewing St  
Seattle, WA 98119

Office: 206-236-1700 ext. 3  
www.seabornpiledriving.com

Scope of Work: We propose to repair the existing dock and swim step with grated decking material, remove (1) existing boat lift with a canopy, and repair (11) existing piles.

County: King County  
Location: Lake Washington

Applicant: McMillan Residence  
3425 67th Ave SE  
Mercer Island, WA 98040

Datum: CORPS OF ENGINEERS 1919  
SW Quarter Of Section 12, Township 24, Range 04

Adjacent Owners:  
AHRENS EDWARD D  
3265 67TH AVE SE 98040  
BEHAR RONALD+JAY-CO-TTEES  
3428 67TH AVE SE 98040

**SHEET  
3.0**

# PROPOSED CONDITIONS

**\*\*CLEAN UP LAKE AROUND PROJECT\*\***

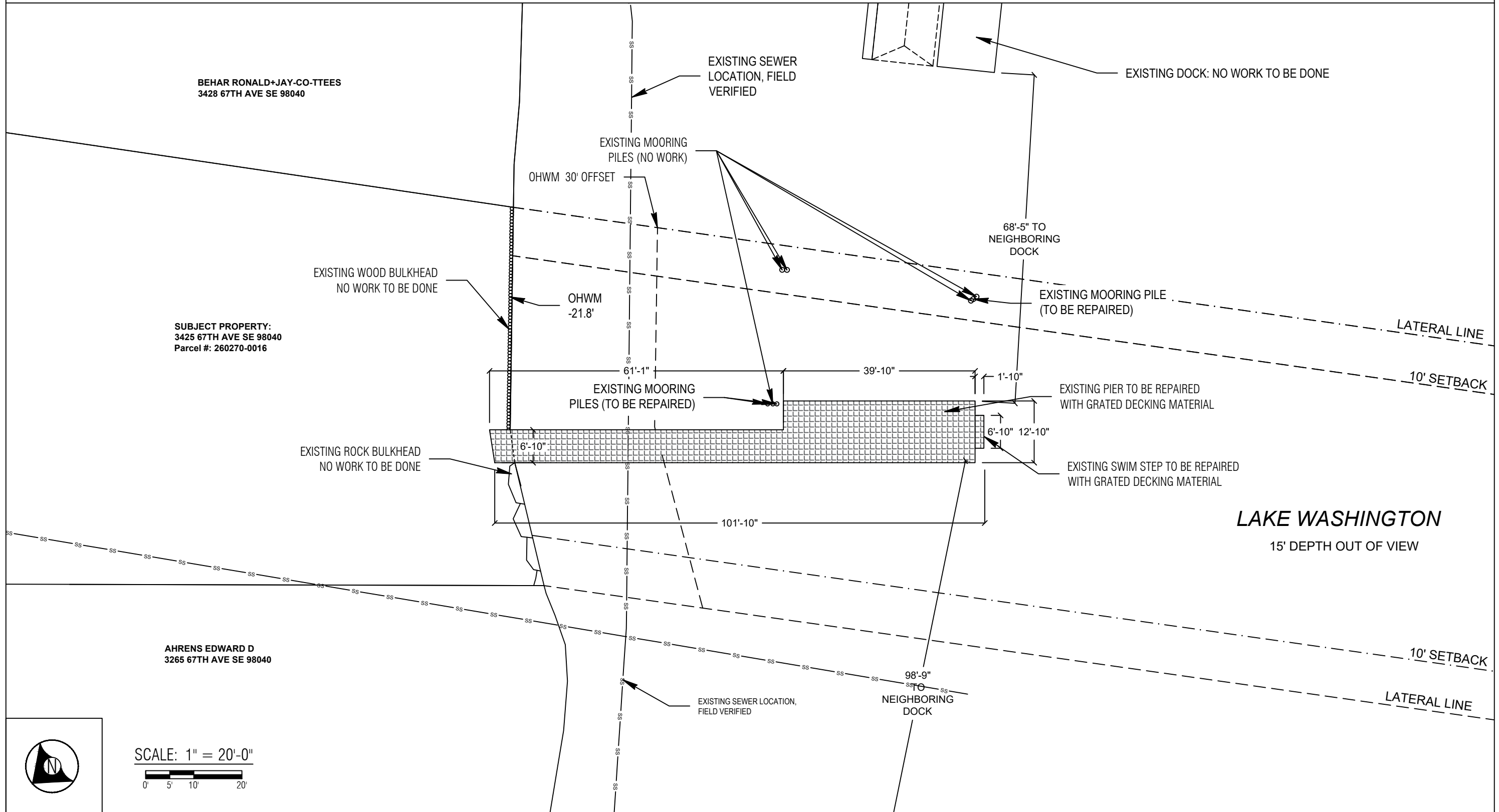

County: King County  
 Location: Lake Washington

Applicant: McMillan Residence  
 3425 67th Ave SE  
 Mercer Island, WA 98040

Datum: CORPS OF ENGINEERS 1919  
 SW Quarter Of Section 12, Township 24, Range 04

Adjacent Owners:  
 BEHAR RONALD+JAY-CO-TTEES  
 3428 67TH AVE SE 98040

AHRENS EDWARD D  
 3265 67TH AVE SE 98040

Last Updated: 9/12/2023 11:36 AM Shop  
 Created: 04-04-23

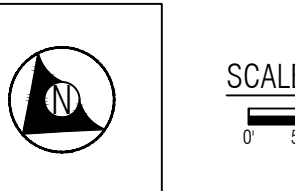

Seaborn Pile Driving  
 1080 W Ewing St  
 Seattle, WA 98119

Office: 206-236-1700 ext. 3  
[www.seabornpiledriving.com](http://www.seabornpiledriving.com)

Scope of Work: We propose to repair the existing dock and swim step with grated decking material, remove (1) existing boat lift with a canopy, and repair (11) existing piles.

**SHEET**  
**4.0**

NWS-2023-XXX  
 PAGE 4 OF 10

# PIER DETAILS - EXISTING/PROPOSED PLAN VIEW

## LEGEND

- (11) EXISTING PILES - TO BE REPAIRED
- (16) EXISTING PILES - NO WORK TO BE DONE

Existing Pier Overwater: 908 sqft  
Existing Pier total: 937 sqft

Existing Canopy: 236 sqft

New Pier Overwater: 908 sqft  
New Pier total: 937 sqft

\*\*Grated decking is 43% open area

## EXISTING

- (173 Inft) EXISTING CAPS
- (227 Inft) EXISTING PILES
- (994 Inft) EXISTING STRINGERS
- (223 Inft) EXISTING EDGE BEAMS

## TO BE REPAIRED

- (127 Inft) EXISTING CAPS TO BE REPAIRED
- (61 Inft) EXISTING PILES TO BE REPAIRED
- (414 Inft) EXISTING STRINGERS TO BE REPAIRED
- (210 Inft) EXISTING EDGE BEAM TO BE REPAIRED

(1617 Inft) TOTAL STRUCTURE ELEMENTS

(812 Inft) TOTAL STRUCTURE ELEMENTS TO BE REPAIRED

$812/1617 = 50\%$

12" 12"

\*414 Inft stringers to be replaced with steel frames\*

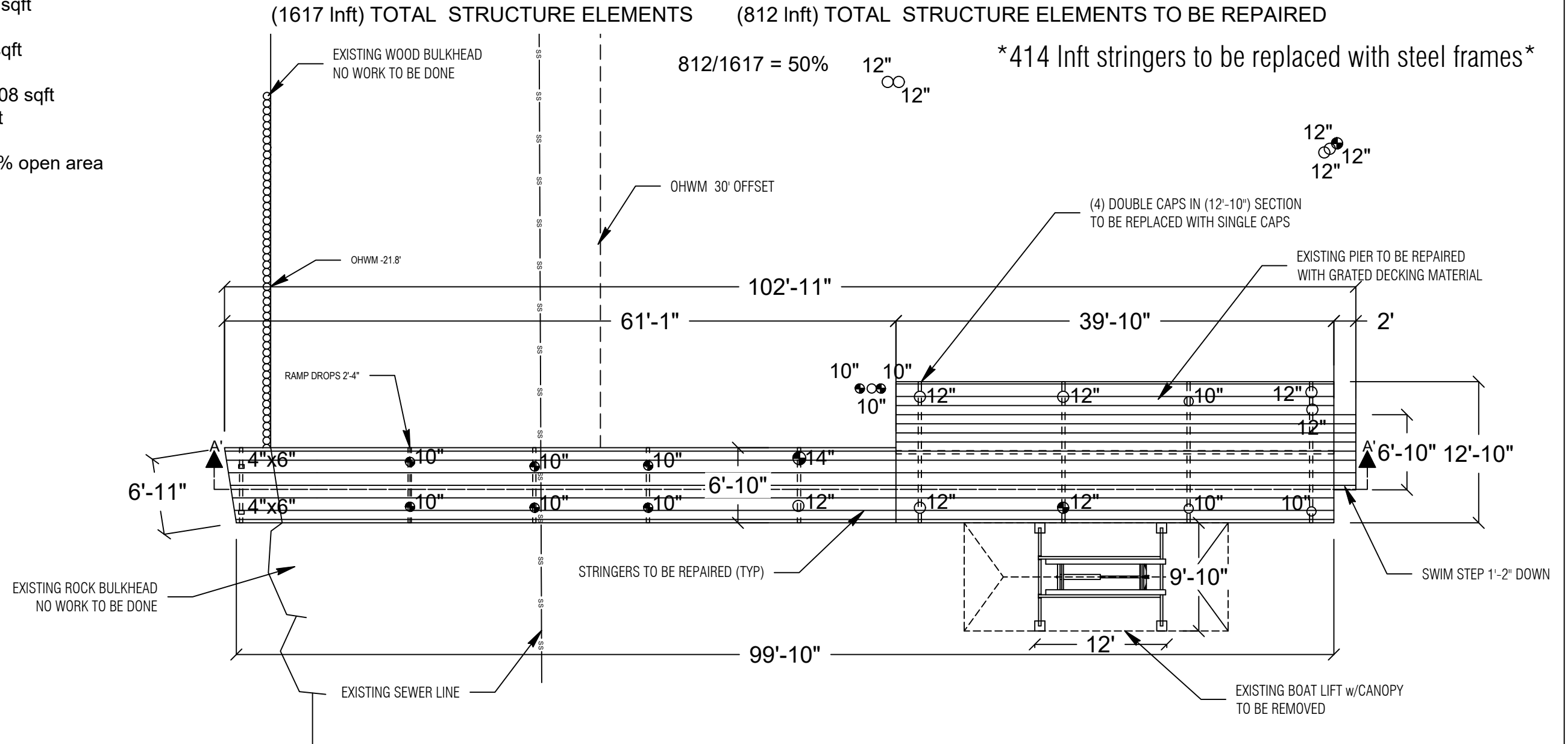

PLAN VIEW



Seaborn Pile Driving  
1080 W Ewing St  
Seattle, WA 98119

Office: 206-236-1700 ext. 3  
www.seabornpiledriving.com

Scope of Work: We propose to repair the existing dock and swim step with grated decking material, remove (1) existing boat lift with a canopy, and repair (11) existing piles.

County: King County  
Location: Lake Washington

Applicant: McMillan Residence  
3425 67th Ave SE  
Mercer Island, WA 98040

Datum: CORPS OF ENGINEERS 1919  
SW Quarter Of Section 12, Township 24, Range 04

Adjacent Owners:  
AHRENS EDWARD D  
3285 67TH AVE SE 98040

BEHAR RONALD+JAY-CO-TTEES  
3428 67TH AVE SE 98040

Created: 04-04-23

Last Updated: 9/12/2023 11:36 AM Shop

SHEET  
5.0

# PIER DETAILS EXISTING/PROPOSED - SECTION VIEW

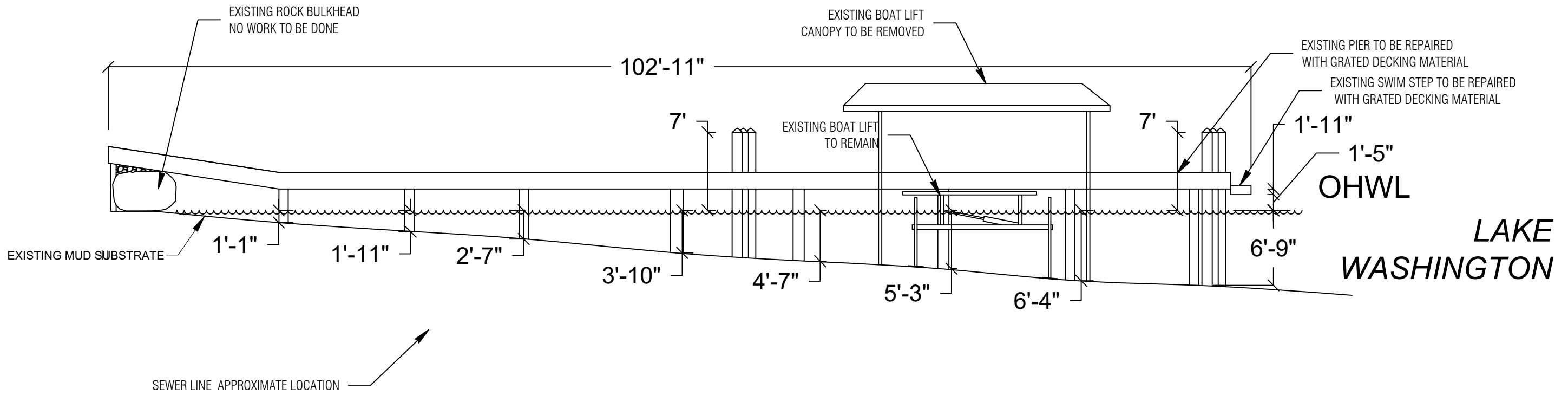

SECTION VIEW: A'-A'



Seaborn Pile Driving  
1080 W Ewing St  
Seattle, WA 98119  
Office: 206-236-1700 ext. 3  
www.seabornpiledriving.com

Scope of Work: We propose to repair the existing dock and swim step with grating decking material, remove (1) existing boat lift with a canopy, and repair (11) existing piles.

County: King County  
Location: Lake Washington

Applicant: McMillan Residence  
3425 67th Ave SE  
Mercer Island, WA 98040

Datum: CORPS OF ENGINEERS 1919  
SW Quarter Of Section 12, Township 24, Range 04

Adjacent Owners:  
AHRENS EDWARD D  
3285 67TH AVE SE 98040

BEHAR RONALD+JAY-CO-TTEES  
3428 67TH AVE SE 98040

**SHEET**  
**6.0**

NWS-2023-XXX  
PAGE 6 OF 10

Last Updated: 9/12/2023 11:36 AM Shop

Created: 04-04-23

# BMP INFORMATION

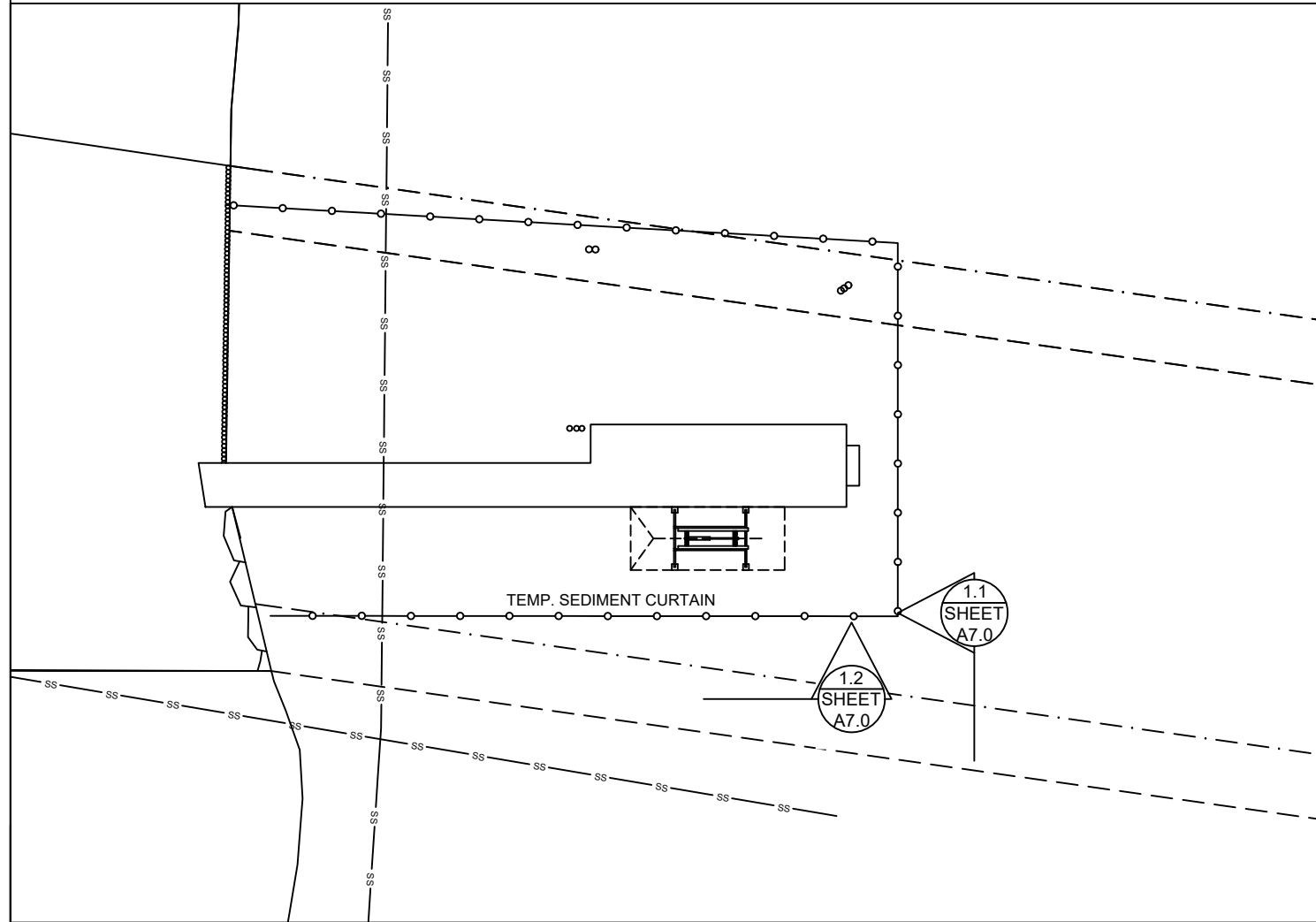

## BMP NOTES:

- A. Constant vigilance shall be kept for the presence of protected fish species during all aspects of the proposed action, particularly during in-water activities such as vessel movement, deployment of anchors & spuds, pile driving, dredging, and placement of gravels and other fill.
  1. The project manager shall designate an appropriate number of competent observers to survey the project site and adjacent areas for protected species, including the presence of fish as conditions allow.
  2. Visual surveys shall be made prior to the start of work each day, and prior to resumption of work following any break of more than an hour. Periodic additional visual surveys throughout the work day are strongly recommended.
  3. All in-water work shall be done during the in-water work window for the waterbody. Where there is a difference between the USCOE and WDFW work windows, the overlap of the two shall apply.
  4. All pile driving and extraction shall be postponed or halted when obvious aggregations or schooling of fish are observed within 50 yards of that work, and shall only begin/resume after the animals have voluntarily departed the area.
  5. When piloting vessels, vessel operators shall operate at speeds and power settings to avoid grounding vessels, and minimize substrate scour and mobilization of bottom sediments.
- B. No contamination of the marine environment shall result from project-related activities.
  1. Appropriate materials to contain and clean potential spills shall be stored and readily available at the work site and/or aboard project-related vessels.
  2. The project manager and heavy equipment operators shall perform daily pre-work equipment inspections for cleanliness and leaks. All heavy equipment operations shall be postponed or halted should a leak be detected, and shall not proceed until the leak is repaired and the equipment is cleaned.
  3. To the greatest extent practicable, utilize biodegradable oils for equipment that would be operated in or near water.
  4. Fueling of land-based vehicles and equipment shall take place at least 50 feet away from the water, preferably over an impervious surface. Fueling of vessels shall be done at approved fueling facilities.
  5. Turbidity and siltation from project-related work shall be minimized and contained through the appropriate use of erosion control practices, effective silt containment devices, and the curtailment of work during adverse weather and tidal/flow conditions.
  6. All wastes shall be collected and contained for proper disposal at approved upland disposal sites appropriate for the material(s).
  7. When removing piles and other similarly treated wood, containment curtain must fully enclose the work area. Wood debris, oils, and any other materials released into lake waters must be collected, removed, and properly disposed of at approved disposal sites.
  8. All in- and over-water wood cutting would be limited to the minimum required to remove the subject wood component, and all cutting work should be enclosed within floating containment curtain.
  9. When removing piles, no actions shall be taken that would cause adhering sediments to return to lake waters.
  10. Above-water containment shall be installed around removed piles to prevent sediment laden waters from returning to lake waters.
  11. Construction staging (including stocking of materials, etc.) will occur on the supply barge.
  12. All Exposed wood to be used on the project will be treated with a cheminite treatment.

DETAIL 1.1

DETAIL 1.2

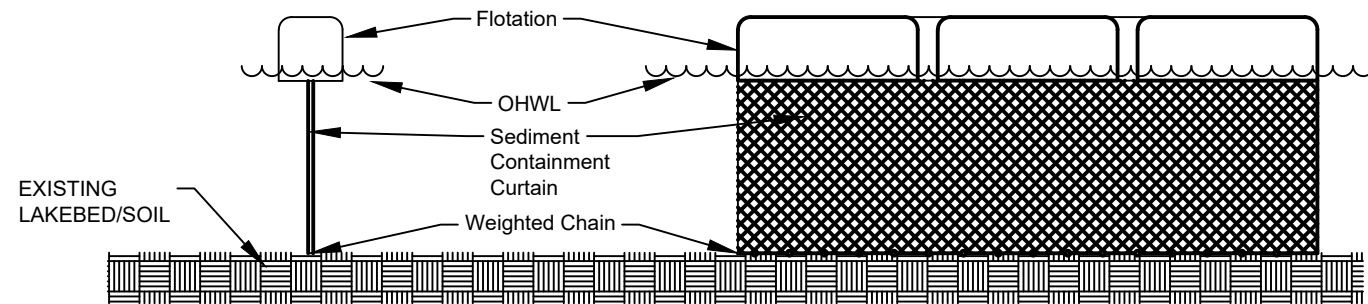

DETAIL 1.1 & 1.2



Seaborn Pile Driving  
1080 W Ewing St  
Seattle, WA 98119

Office: 206-236-1700 ext. 3  
www.seabornpiledriving.com

Scope of Work: We propose to repair the existing dock and swim step with grated decking material, remove (1) existing boat lift with a canopy, and repair (11) existing piles.

County: King County  
Location: Lake Washington

Applicant: McMillan Residence  
3425 67th Ave SE  
Mercer Island, WA 98040

Datum: CORPS OF ENGINEERS 1919  
SW Quarter Of Section 12, Township 24, Range 04

Adjacent Owners:  
AHRENS EDWARD D  
3285 67TH AVE SE 98040

BEHAR RONALD+JAY-CO-TTEES  
3428 67TH AVE SE 98040

Created: 04-04-23

Last Updated: 9/12/2023 11:36 AM Shop

**SHEET**  
**7.0**

# MITIGATION PLAN

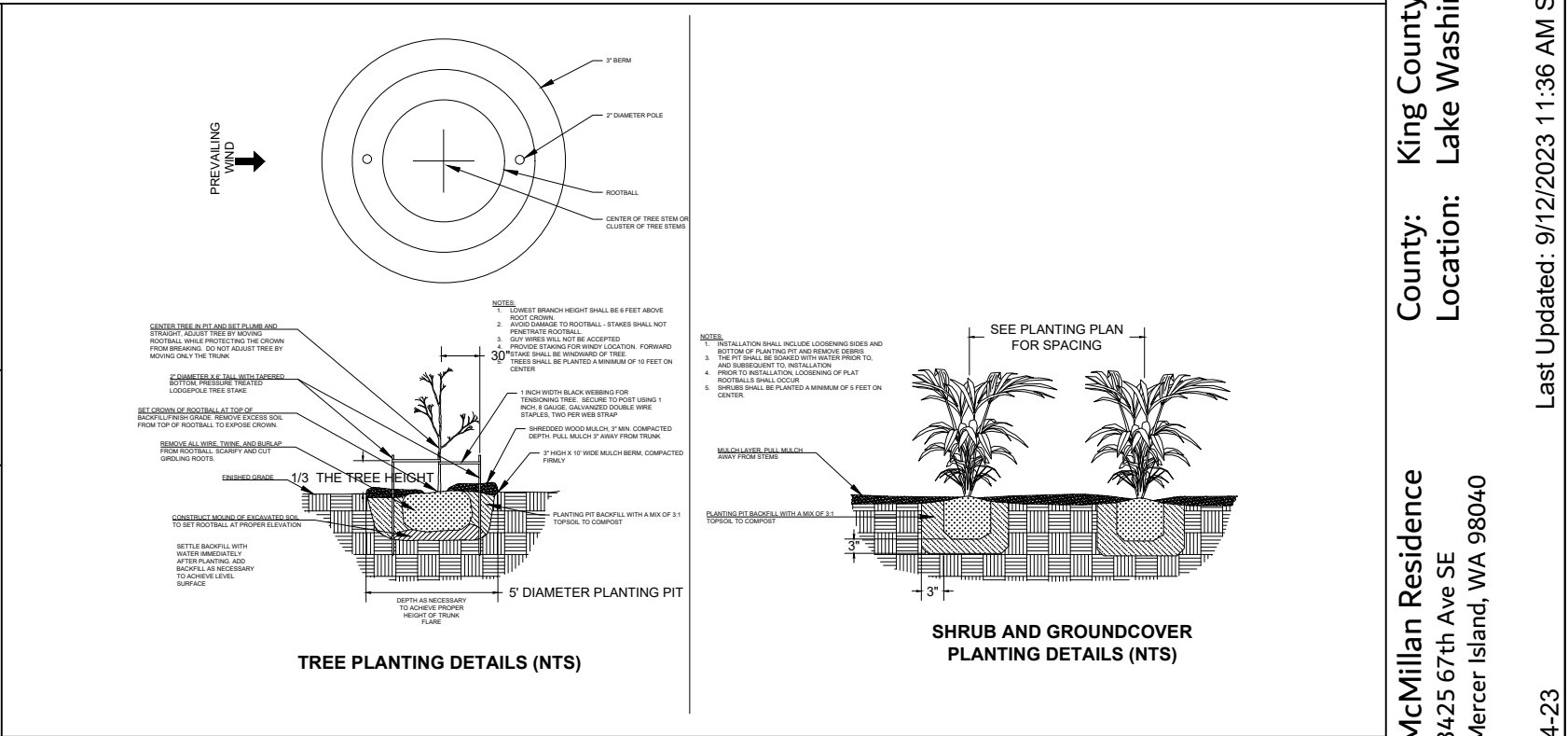

**Notes:**

1. Shrubs are shown, and shall be planted, at least five feet on center. Trees are shown, and shall be planted, at least ten feet to center.
2. The property owner will implement and abide by the shoreline planting plan. The plants shall be installed before or concurrent with the work authorized by this permit. A report, as-built drawing and photographs demonstrating the plants have been installed or a report on the status of project construction will be submitted to the U.S. Army Corps of Engineers, Seattle District, Regulatory Branch, within 12 months from the date of permit issuance. This reporting requirement may be met by completing and submitting a U.S. Army Corps of Engineers approved Report for Mitigation Work Completion form.
3. The property owner will maintain and monitor the survival of installed shoreline plantings for five years after the U.S. Army Corps of Engineers accepts the as-built report. Installed plants shall achieve 100% survival during monitoring Years 1 and 2. Installed plants shall achieve at least 80% survival during monitoring Years 3, 4 and 5. Percent survival is based on the total number of plants installed in accordance with the approved riparian planting plan. Individual plants that die will be replaced with native riparian species in order to meet the survival performance standards.
4. The property owner will provide annual monitoring reports for five years (Monitoring Years 1-5). Each annual monitoring report will include written and photographic documentation on plant mortality and replanting efforts and will document whether the performance standards are being met. Photos will be taken from established points and used repeatedly for each monitoring year. In addition to photos at designated points, photo documentation will include a panoramic view of the entire planting area. Submitted photos will be formatted on standard 8 1/2 x 11" paper, dated with the date the photo was taken, and clearly labeled with the direction from which the photo was taken. The photo location points will be identified on an appropriate drawing. Annual shoreline planting monitoring reports will be submitted to the U.S. Army Corps of Engineers, Seattle District, Regulatory Branch, by November 31 of each monitoring year. This reporting requirement may be met by completing and submitting a U.S. Army Corps of Engineers approved Mitigation Planting Monitoring Report form.

No mitigation proposed due to full shoreline.



Seaborn Pile Driving  
 1080 W Ewing St  
 Seattle, WA 98119  
 Office: 206-236-1700 ext. 3  
 www.seabornpiledriving.com

Scope of Work: We propose to repair the existing dock and swim step with grated decking material, remove (1) existing boat lift with a canopy, and repair (11) existing piles.

**County:** King County  
**Location:** Lake Washington  
**Applicant:** McMillan Residence  
 3425 67th Ave SE  
 Mercer Island, WA 98040  
**Datum:** CORPS OF ENGINEERS 1919  
 SW Quarter Of Section 12, Township 24, Range 04  
**Adjacent Owners:**  
 AHRENS EDWARD D  
 3285 67TH AVE SE 98040  
 BEHAR RONALD+JAY-CO-TTEES  
 3428 67TH AVE SE 98040  
**Created:** 04-04-23  
**Last Updated:** 9/12/2023 11:36 AM Shop  
**SHEET 8.0**  
 NWS-2023-XXX  
 PAGE 8 OF 10



# EXISTING PLANT PLAN

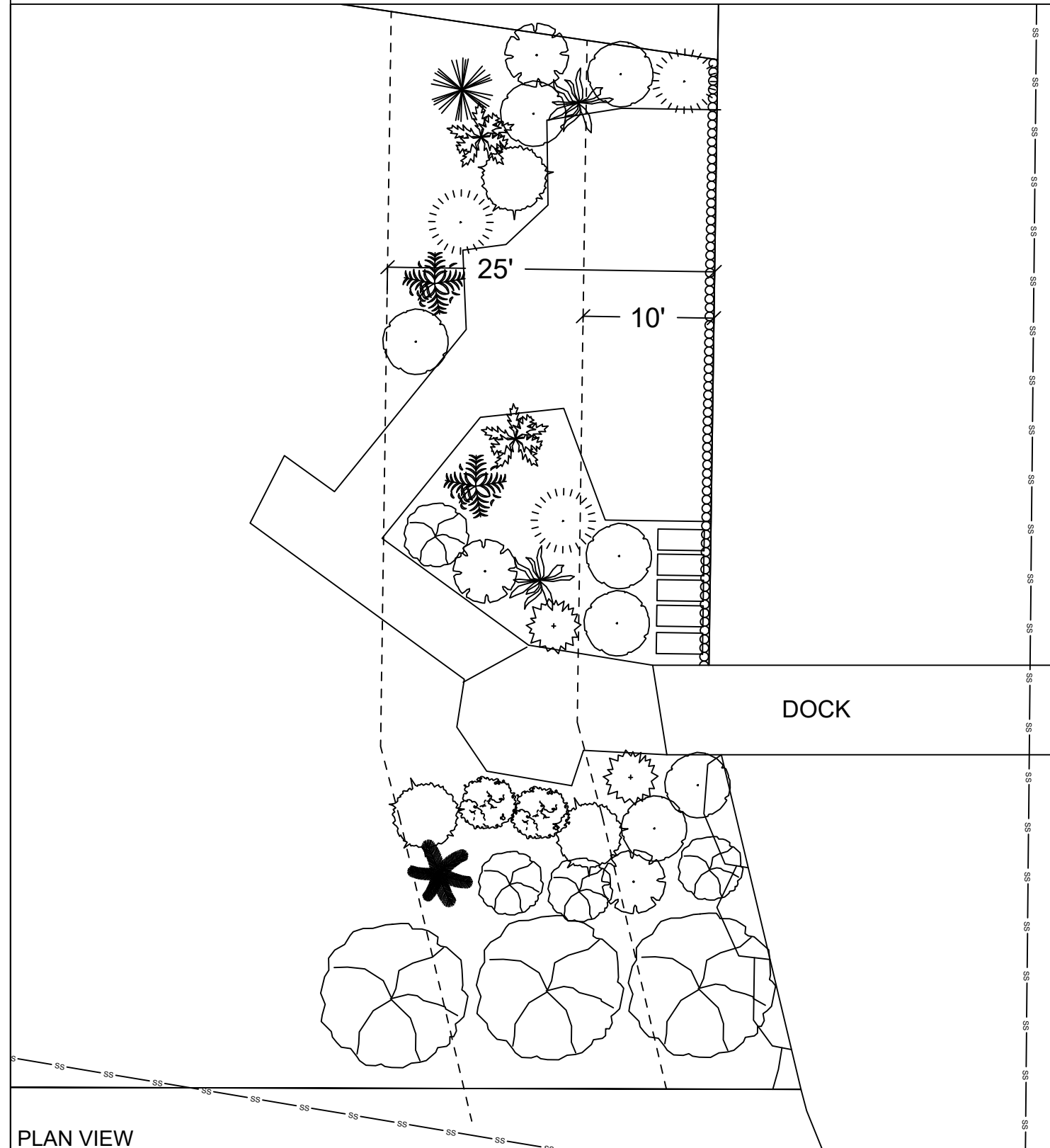

## EXISTING PLANTING SPECIES/QUANTITIES

SYMBOL	SCIENTIFIC NAME	COMMON NAME	QTY	SIZE
	<i>Acer Palmatum</i>	Japanese Maple	6	1'x1'x1'
	<i>Pieris japonica</i>	Japanese Andromeda	2	~2ft
	<i>Juniperus horizontalis</i>	Creeping Juniper	2	~ 1ft
	<i>Pinus mugo</i>	Mugo Pine	2	~3ft x 6ft
	<i>Chamaecyparis thyoides</i>	Southern White Cedar	N/A	N/A
	<i>Spiraea japonica</i>	Japanese Meadow Sweet	2	~4ftx2ftx1ft
	<i>Hydrangea macrophylla</i>	Big Leaf Hydrangea	1	~4ft
	<i>Arctostaphylos uva-ursi</i>	Kinnikinnik	2	~3ftx8ft
	<i>Rhododendron simsii</i>	Indian Azalea	3	~2ftx2ftx2ft
	<i>Euphorbia esula</i>	Leafy Spurge	2	~1ftx1ftx1ft
	<i>Iris sibirica</i>	Siberian Iris	1	N/A
	<i>Euphorbia characias</i>	Mediterranean Spurge	2	N/A

Seaborn Pile Driving  
1080 W Ewing St  
Seattle, WA 98119

Office: 206-236-1700 ext. 3  
www.seabornpiledriving.com

Scope of Work: We propose to repair the existing dock and swim step with grated decking material, remove (1) existing boat lift with a canopy, and repair (11) existing piles.



County: King County  
Location: Lake Washington

Applicant: McMillan Residence  
3425 67th Ave SE  
Mercer Island, WA 98040

Datum: CORPS OF ENGINEERS 1919  
SW Quarter Of Section 12, Township 24, Range 04  
Adjacent Owners:  
AHRENS EDWARD D  
3285 67TH AVE SE 98040  
BEHAR RONALD+JAY-CO-TTEES  
3428 67TH AVE SE 98040

**SHEET**  
**9.0**

# HARDSCAPE CALCULATION DRAWING

## Allowed Impervious Quantities

SETBACK (total sqft)	ALLOWED	Legally Non-Conforming	CURRENTLY USED	REMOVING	PROPOSED
0' - 25' SETBACK (2073.7337 sqft)	10% (207.37337 sqft)	44.9431% (932 sqft)	44.9431% (932 sqft)	0% (0 sqft)	44.9431% (932 sqft)
25' - 50' SETBACK (2134.4192 sqft)	30% (640.32576sqft)	37.8088% (807 sqft)	37.8088% (807 sqft)	0% (0 sqft)	37.8088% (807 sqft)

## LEGEND

DESCRIPTION	AREA	HATCH
DECKING 25FT SETBACK	683 sqft	
GRAVEL 25FT SETBACK	91 sqft	
CONCRETE WALKWAY 25FT SETBACK	130 sqft	
STONE WALKWAY 25FT SETBACK	28 sqft	
GRAVEL 50FT SETBACK	217 sqft	
PATIO 50FT SETBACK	513 sqft	
DECKING 50FT SETBACK	77 sqft	

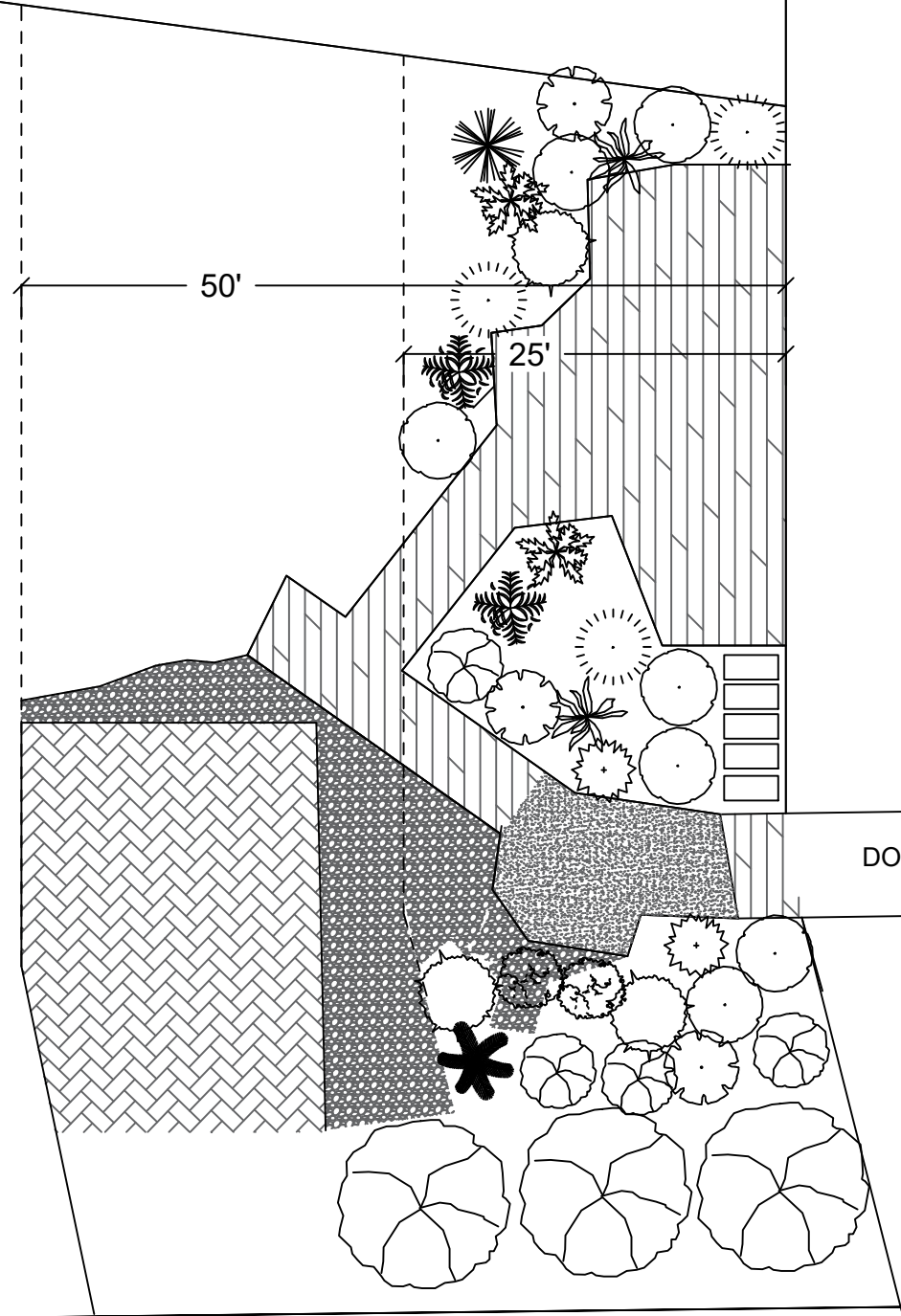

County: King County  
 Location: Lake Washington  
 Applicant: McMillan Residence  
 3425 67th Ave SE  
 Mercer Island, WA 98040  
 Datum: CORPS OF ENGINEERS 1919  
 SW Quarter Of Section 12, Township 24, Range 04  
 Adjacent Owners:  
 AHRENS EDWARD D  
 3285 67TH AVE SE 98040  
 BEHAR RONALD+JAY-CO-TTEES  
 3428 67TH AVE SE 98040  
 Created: 04-04-23  
 Last Updated: 9/12/2023 11:36 AM Shop



Seaborn Pile Driving  
 1080 W Ewing St  
 Seattle, WA 98119  
 Office: 206-236-1700 ext. 3  
[www.seabornpiledriving.com](http://www.seabornpiledriving.com)

Scope of Work: We propose to repair the existing dock and swim step with grated decking material, remove (1) existing boat lift with a canopy, and repair (11) existing piles.

**SHEET 10.0**

GENERAL CONDITIONS

1. THE CONTRACTOR SHALL VERIFY AND REVIEW ALL ITEMS WITHIN THE DRAWINGS PRIOR TO PROCEEDING WITH THE WORK. NOTIFY THE ENGINEER IMMEDIATELY WITH ANY DISCREPANCIES.
2. IF A SPECIFIC DETAIL IS NOT SHOWN FOR ANY PART OF THE WORK, THE CONSTRUCTION SHALL BE THE SAME AS FOR SIMILAR WORK.
3. DIMENSIONS ARE NOT TO BE SCALED FROM THE PLANS, SECTIONS, OR DETAILS WITHIN THE DRAWINGS.
4. THE CONTRACTOR SHALL BE SOLELY RESPONSIBLE FOR THE CONSTRUCTION MEANS, METHODS, TECHNIQUES, SEQUENCE, AND PROCEDURES.
5. ALL WORK SHALL CONFORM TO THE MINIMUM STANDARDS OF THE REFERENCED CONSTRUCTION AND ALL OTHER REGULATING AGENCIES, EXERCISING AUTHORITY OVER ANY PORTION OF THE WORK.
6. THE PROJECT SPECIFICATIONS AND SPECIFIC NOTES AND DETAILS IN THE DRAWINGS SHALL TAKE PRECEDENCE OVER GENERAL NOTES.
7. NOTIFY THE ENGINEER OF ALL CHANGES MADE IN THE FIELD PRIOR TO INSTALLATION.
8. CONSTRUCTION TOLERANCE: VERTICAL 1/8", PLUMBNESS 1", HORIZONTAL DRIFT 1".
9. COMPLY WITH PROJECT PERMITS.

DESIGN CRITERIA

DESIGN CODE: AASHTO LRFD, ASCE DESIGN OF MARINE FACILITIES

WIND DESIGN: V=83 MPH

DESIGN VESSEL: 26' STANDARD VESSEL

WAVE DESIGN: SIGNIFICANT WAVE HEIGHT 1 FT  
WAVE PERIOD 15 SEC  
WAVE LENGTH 88.5 FT

LIVE LOAD: 40 PSF

STRUCTURAL STEEL

1. ALL PLATES SHALL CONFORM TO ASTM 50.
2. ALL WF SHAPED SHALL CONFORM TO ASTM A992, FY = 50 KSI.
3. ALL PILES SHALL CONFORM TO ASTM A252 GRADE 3 FY = 45 KSI.
4. ALL BOLTS SHALL CONFORM TO ASTM A307, UNO.
5. ALL NUTS SHALL CONFORM TO ASTM A563, UNO.
6. ALL WASHERS SHALL CONFORM TO ASTM F436, UNO.
7. ALL THREADED RODS SHALL CONFORM TO ASTM F1554, GRADE 36.
8. ALL STEEL MEMBERS THAT ARE NOT EPOXY COASTED SHALL BE HOT DIP GALVANIZED IN ACCORDANCE WITH ASTM A153 AS APPLICABLE.

WELDING

1. ALL WELDING SHALL BE PERFORMED BY WELDERS QUALIFIED FOR THE WELD AND POSITION SHOWN IN ACCORDANCE WITH AWS AND HAVING CURRENT CERTIFICATION FROM WABO.
2. ALL WELDS SHALL BE PERFORMED WITH PROCEDURES PRE-QUALIFIED OR QUALIFIED IN ACCORDANCE WITH AWS D1.1.
3. THE WELDS SHOWN ARE FOR THE FINAL CONNECTIONS. FIELD WELD SYMBOLS ARE SHOWN WHERE REQUIRED BY THE STRUCTURAL DESIGN. THE CONTRACTOR IS RESPONSIBLE FOR DETERMINING IF A WELD SHOULD BE SHOP OR FIELD WELDED IN ORDER TO FACILITATE THE STRUCTURAL STEEL ERECTION.
4. WELDING ELECTRODES SHALL BE 70 KSI STRENGTH AND SHALL BE "LOW-HYDROGEN ELECTRODES"

MINIMUM OPEN AREA OF 60%

ABBREVIATIONS

@	AT
AWS	AMERICAN WELDING SOCIETY
CL	CENTER LINE
CLR	CLEAR
COL	COLUMN
CONT.	CONTINUOUS
DF	DOUF FIR
EA	EACH
EX OR (E)	EXISTING
GLB	GLULAM BEAM
LLH	LONG LEG HORIZONTAL
MIN	MINIMUM
MNFR	MANUFACTURER
OC	ON CENTER
OPP	OPPOSITE
PL	PLATE
PSI	POUND PER SQUARE INCH
PSF	POUND PER SQUARE FOOT
P.T.	PRESERVATIVE TREATED
SF	SQUARE FOOT
REF	REFERENCE
SIM	SIMILAR
SS	STAINLESS STEEL
t	THICK
TYP	TYPICAL
UNO	UNLESS NOTED OTHERWISE
VIF	VERIFY IN FIELD
WABO	WASHINGTON ASSOCIATION OF BUILDING OFFICIALS
WF	WIDE FLANGE
W/	WITH



Seaborn Pile Driving  
1080 W Ewing St  
Seattle, WA 98119

Office: 206-236-1700 ext. 3  
www.seabornpiledriving.com



9706 4th Ave NE  
Suite 300  
Seattle, WA 98115

P: 206.523.0024  
www.dcgengr.com

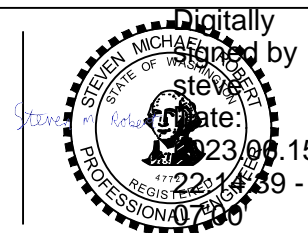

DRAWN BY: IK  
DESIGNED BY: JS  
CHECKED BY: DT

Scope of Work: We propose to repair the existing dock and swim step with grated decking material, and repair (11) existing piles.

**SHEET  
S1.01**

Datum: CORPS OF ENGINEERS 1919  
SW Quarter Of Section 12, Township 24, Range 04

Adjacent Owners:  
AHRENS EDWARD D  
3285 67TH AVE SE 98040

BEHAR RONALD+JAY-CO-TTEES  
3428 67TH AVE SE 98040

Applicant: McMillan Residence  
3425 67th Ave SE  
Mercer Island, WA 98040

County: King County  
Location: Lake Washington

Created: 04-04-23

Last Updated: 6/15/2023 12:58 PM Jimi

**STATEMENT OF SPECIAL INSPECTIONS (CONT)**

**SOILS SUPPORTING FOUNDATIONS**

- PERIODIC: VERIFY MATERIALS BELOW FOOTINGS ARE ADEQUATE TO ACHIEVE THE DESIGN BEARING CAPACITY
- PERIODIC: VERIFY EXCAVATIONS ARE EXTENDED TO PROPER DEPTH AND HAVE REACHED PROPER MATERIAL
- PERIODIC: PERFORM CLASSIFICATION AND TESTING OF CONTROLLED FILL MATERIALS
- CONT: VERIFY USE OF PROPER MATERIALS, DENSITIES AND LIFT THICKNESS DURING PLACEMENT AND COMPACTION
- PERIODIC: PRIOR TO PLACEMENT OF CONTROLLED FILL, INSPECT SUBGRADE AND VERIFY THAT SITE HAS BEEN PREPARED PROPERLY

**STRUCTURAL CONCRETE**

- PERIODIC: INSP. OF REINFORCING STEEL AND PLACEMENT
- CONT: INSPECT BOLTS TO BE INSTALLED IN CONCRETE PRIOR TO AND DURING PLACEMENT OF CONCRETE
- PERIODIC: VERIFY USE OF REQUIRED DESIGN MIX
- CONT: SAMPLING FRESH CONCRETE & PERFORMING SLUMP AND AIR CONTENT TEST & DETERMINING THE TEMPERATURE OF FRESH CONCRETE AT THE TIME OF MAKING SPECIMENS FOR STRENGTH TEST
- CONT: INSPECTION OF CONCRETE PLACEMENT FOR PROPER APPL. TECHNIQUES
- PERIODIC: INSPECTION FOR MAINTENANCE OF SPECIFIED CURING TEMPERATURE AND TECHNIQUE
- PERIODIC: VERIFICATION OF IN-SITU CONCRETE STRENGTH, PRIOR TO REMOVAL OF SHORES AND FORMS FROM BEAMS AND STRUCTURAL SLABS
- PERIODIC: INSPECT FORMWORK FOR SHAPE, LOCATION AND DIM. OF THE CONCRETE MEMBER BEING FORMED
- PERIODIC: POST-INSTALLED AND ADHESIVE ANCHORS

**STRUCTURAL STEEL**

- PERIODIC: HIGH-STRENGTH BOLTS, NUTS AND WASHERS IDENTIFICATION MARKINGS TO CONFORM TO ASTM STANDARDS SPECIFIED IN THE APPROVED CONSTRUCTION DOCUMENTS, MANUFACTURE'S CERTIFICATE OF COMPLIANCE REQUIRED
- PERIODIC: INSPECTION OF HIGH-STRENGTH BOLTING BEARING-TYPE CONNECTIONS
- PERIODIC: STRUCTION STEEL MANUFACTURER'S CERTIFIED MILL TEST REPORTS REQUIRED
- PERIODIC: INSPECTION OF STEEL FRAME BRACING & STIFFENER DETAILS FOR COMPLIANCE WITH APPROVED CONSTRUCTION DOCUMENTS
- PERIODIC: APPLICATIONS OF JOINT DETAILS AT EACH CON.
- WELDING**
- CONT: COMPLETE AND PARTIAL PENETRATION GROOVE WELDS
- CONT: FILLET WELDS > 5/16" AND MULTIPASS FILLET WELDS
- PERIODIC: FILLET WELDS < 5/16"
- PERIODIC: METAL DECK WELDS
- PERIODIC: LIGHT GAUGE METAL WELDS
- PERIODIC: WELD FILLER MATERIAL IDENTIFICATION MARKINGS TO CONFORM TO AWS STANDARDS SPECIFIED IN THE APPROVED CONSTRUCTION DOCUMENTS, MANUFACTURER'S CERTIFICATION OF COMPLIANCE REQ.
- CONT: WELDING OF REINFORCEMENT STEEL RESISTING SEISMIC FORCES, INDICATED ON PLANS AND DETAILS AS LRFS ELEMENTS AND CONNECTIONS
- PERIODIC: VERIFICATION OF WELDABILITY OF REINFORCING STEEL OTHER THAN ASTM A706
- CONT: WELDING OF STIRRUPS, HOOPS OR TIERS
- PERIODIC: ALL OTHER REINFORCEMENT WELDS, U.N.O.

**ROUGH CARPENTRY / WOOD**

- PERIODIC: NAILING OF ROOF, WALL, & FLOOR SHEATHING
- PERIODIC: NAILING BOLTING OF STRAPS, HOLDDOWNS, BRACES AND DRAG STRUTS
- PERIODIC: INSTALLATION OF TIMBER CONNECTORS

**COLD-FORMED STEEL FRAMING**

- PERIODIC: SCREW ATTACHMENT, BOLTING, AND ANCHORING OF STRAPS, HOLDDOWNS, BRACES, DRAG STRUTS, AND ROOF, WALLS, AND FLOOR

**STATEMENT OF SPECIAL INSPECTIONS**

1. THE OWNER SHALL EMPLOY ONE OR MORE SPECIAL INSPECTORS TO PROVIDE INSPECTIONS DURING CONSTRUCTION. THE SPECIAL INSPECTOR SHALL BE A QUALIFIED PERSON WHO SHALL DEMONSTRATE COMPETENCE, TO THE SATISFACTION OF THE BUILDING OFFICIAL, FOR THE INSPECTION OF THE PARTICULAR TYPE OF CONSTRUCTION OR OPERATION REQUIRING SPECIAL INSPECTION.
2. SPECIAL INSPECTIONS ARE NOT REQUIRED WHERE THE WORK IS DONE ON THE PREMISES OF A FABRICATOR REGISTERED AND APPROVED TO PERFORM SUCH WORK WITHOUT SPECIAL INSPECTION. APPROVED FABRICATORS MUST SUBMIT A CERTIFICATE OF COMPLIANCE FOR OFFSITE FABRICATIONS SUCH AS STRUCTURAL STEEL, PRECAST CONCRETE, GLUED LAMINATED TIMBER, ETC.
3. ALL INSPECTIONS SHALL BE PERFORMED BY INDEPENDENT SPECIAL INSPECTORS. JOB SITE VISITS BY THE STRUCTURAL ENGINEER OR BUILDING OFFICIAL DO NOT CONSTITUTE AND ARE NOT A SUBSTITUTE FOR INSPECTION BY A SPECIAL INSPECTOR.
4. ALL INSPECTION REPORTS SHALL BE SUBMITTED TO THE BUILDING OFFICIAL AND E.O.R. THE FINAL REPORTS BY THE SPECIAL INSPECTOR(S) MUST CERTIFY THAT THE ENTIRE STRUCTURAL SYSTEM COMPLIES WITH THE APPROVED PLANS AND SPECIFICATIONS.
5. IT IS SOLELY THE CONTRACTOR'S RESPONSIBILITY TO SEE THAT THESE INSPECTIONS ARE PERFORMED.
6. WORK REQUIRING SPECIAL INSPECTION SHALL BE INSPECTED BY THE SPECIAL INSPECTOR WHO IS PRESENT IN THE AREA WHERE THE WORK IS PERFORMED AND AT THE COMPLETION OF WORK. CONTINUOUS INSPECTION CONSIST OF FULL-TIME INSPECTION; PERIODIC INSPECTION CONSIST OF PART-TIME OR INTERMITTENT INSPECTION.
7. THE FOLLOWING SPECIAL INSPECTIONS ARE IN ADDITION TO THE INSPECTION BY THE BUILDING OFFICIAL. THIS LIST IS NOT INTENDED TO BE ALL INCLUSIVE.

**STRUCTURAL OBSERVATIONS**

1. VISUAL OBSERVATION WILL BE PERFORMED AT THE DISCRETION OF THE OWNER, ARCHITECT, E.O.R. AND AS REQUIRED BY THE BUILDING OFFICIAL IN ACCORDANCE WITH THE BUILDING CODE. VISUAL OBSERVATION SHALL NOT BE CONSIDERED AS A SUBSTITUTE FOR THE SPECIAL INSPECTION REQUIREMENTS.
2. IT IS THE RESPONSIBILITY OF HE GENERAL CONTRACTOR TO NOTIFY THE E.O.R AS TO WHEN EACH MAJOR PHASE OF CONSTRUCTION IS READY FOR OBSERVATION A MINIMUM OF FIVE(5) WORKING DAYS IN ADVANCE.
3. THE FOLLOWING MAJOR PHASES OF CONSTRUCTION REQUIRE A SITE VISIT AND STRUCTURAL OBSERVATION REPORT FROM THE S.E.O.R:
  - FOUNDATION REBAR AND ANCHORS - PRIOR TO POUR OF CONCRETE
  - STRUCTURAL FRAMING - AFTER ERECTION AND PRIOR TO CLOSING IN
  - RAISED FLOOR SLABS AND REBAR - PRIOR TO POUR OF CONCRETE
  - ROOF NAILING - PRIOR TO INSTALLATION OF ROOFING AND CRICKETS
  - COMPLETION OF STRUCTURAL SYSTEMS(S)
4. THE CONTRACTOR SHALL BE RESPONSIBLE FOR ENSURING THAT NAILING, REINFORCEMENT, WELDS, CONNECTIONS, ETC. ARE VISIBLE FOR OBSERVATION WHEN THE S.E.O.R IS ON SITE AND FOR ANY SCHEDULING DELAYS DUE TO NONCOMPLIANT ITEMS FOUND DURING OBSERVATION.
5. AT THE CONCLUSION OF WORK INCLUDED N THE PERMIT, THE STRUCTURAL OBSERVER SHALL SUBMIT TO THE BUILDING OFFICIAL A WRITTEN STATEMENT THAT THE SITE VISITS HAVE MADE AND IDENTIFY ANY REPORTED DEFICIENCIES THAT, O THE BEST OF THE STRUCTURAL OBSERVERS' KNOWLEDGE, HAVE NOT BEEN RESOLVED

**STRUCTURAL SUBMITTALS**

1. REVIEW OF SHOP DRAWINGS AND SUBMITTALS BY THE E.O.R IS FOR GENERAL COMPLIANCE WITH THE CONTRACT DOCUMENTS.
2. SHOP DRAWINGS SHALL BE SUBMITTED TO THE E.O.R FOR REVIEW PRIOR TO FABRICATION. THE CONTRACTOR WILL REMAIN RESPONSIBLE FOR ALL ERRORS OF DETAILING, FABRICATION, AND FOR CORRECT FITTING OF ALL STRUCTURAL MEMBERS INCLUDING COORDINATION WITH OTHER TRADES.
  - A. SHOP DRAWINGS SHALL BE SUBMITTED A MINIMUM OF 2 WEEK PRIOR TO SCHEDULED FABRICATION AND SHALL CONSIST OF ONLY ONE SET FOR OUR RECORDS AND ONE REPRODUCIBLE SET. ONE ELECTRONIC SET IS ACCEPTABLE.
  - B. E.O.R WILL RETURN THE REPROUCIBLE OR ELECTRONIC SET CLEARLY MARKED WITH COMMENTS. ANY REQUIRED RECORD SET COPIES SHALL BE MADE FROM THIS RETURNED SET.
  - C. REPRODUCTION OF STRUCTURAL PLANS & DETAILS FOR SHOP DRAWINGS IS PROHIBITED. SUBCONTRACTOR/FABRICATOR IS TO PROVIDE INDEPENDENTLY CREATED DRAWINGS BASED ON THE STRUCTURAL PLANS DETAIL
3. THE FOLLOWING LIST SUMMARIZES IMPORTANT STRUCTURAL SUBMITTALS FOR THIS PROJECT. REFER TO THE SPECIFICATIONS FOR A COMPLETE LIST OF ADDITIONAL REQUIREMENTS

**GENERAL**

- REQD: QUALIFICATION DATA FOR APPROVED INSTALLERS AND FABRICATORS
- REQD: CERTIFICATES OF CONFORMANCE FOR PREFABRICATED MEMBERS
- REQD: PROVIDE PRODUCT DATA FOR ALL MANUFACTURED STRUCTURAL PRODUCTS AND ACCESSORIES USED

**CONCRETE FORMWORK**

- REQD: MANUFACTURER'S PRODUCT DATA AND INSTALLATION INSTRUCTIONS FOR PROPRIETARY MATERIALS INCLUDING FORM COATINGS, MANUFACTURED FORM SYSTEMS, TIES AND ACCESSORIES
- REQD: SHOP DRAWINGS FOR FABRICATION AND ERECTION OF FORMWORK AND SHORING

**CONCRETE REINFORCEMENT**

- REQD:MANUFACTURER'S PRODUCT DATA, SPECIFICATIONS AND INSTALLATION PROCEDURES FOR PROPRIETARY MATERIALS AND REINFORCEMENT
- REQD: STEEL PRODUCERS CERTIFICATES OF MILL ANALYSIS, TENSILE AND BEND TEST
- REQD: SHOP DRAWINGS FOR FABRICATION, BENDING AND PLACEMENT

**CAST-IN-PLACE CONCRETE**

- REQD: DESIGN MIX FOR EACH CONCRETE MIX
- REQD: MATERIAL TEST REPORTS
- REQD: MATERIAL CERTIFICATES FOR CEMENT, AGGREGATES AND ADMIXTURES
- REQD: MANUFACTURER'S PRODUCT DATA FOR WATERSTOPS, BONDING AGENTS, VAPOR RETARDERS, JOINT FILLER, CURING MATERIALS AND FLOOR TREATMENTS
- REQD: SHOP DRAWINGS FOR PROPOSED LOCATIONS OF ADDITIONAL CONSTRUCTION OR CONTROL JOINTS NOT SHOWN ON THE STRUCTURAL PLANS
- REQD: MINUTES FROM PREINSTALLATION CONFERENCE

**STRUCTURAL STEEL**

- REQD: MANUFACTURES MILL CERTIFICATES
- REQD: MILL TEST REPORTS
- REQD: SHOP DRAWINGS FOR FABRICATION AND ASSEMBLY OF MEMBERS
- REQD: ERECTION PLAN SEQUENCE AND PROCEDURES
- REQD: WELDING PROCEDURE SPECIFICATIONS (WPS)
- REQD: CERTIFICATES FOR ALL WELDERS VERIFYING CURRENT AWS QUALIFICATIONS
- REQD: TEST REPORTS FOR SHOP AND FIELD WELDED AND BOLTED CONNECTIONS

**STEEL DECK**

- REQD: SHOP DRAWINGS INDICATING LAYOUT AND DETAILS

**COLD-FORMED METAL FRAMING**

- REQD: SHOP DRAWINGS INDICATING LAYOUT AND DETAILS
- REQD: ENGINEERING CALCULATIONS

**ROUGH CARPENTRY**

- REQD: PRODUCT DATA FOR TREATMENTS AND PRESERVATIVES
- REQD: MATERIAL CERTIFICATES FOR DIMENSION LUMBER

County: King County  
Location: Lake Washington

Applicant: McMillan Residence  
3425 67th Ave SE  
Mercer Island, WA 98040

Datum: CORPS OF ENGINEERS 1919  
SW Quarter Of Section 12, Township 24, Range 04

Adjacent Owners:  
AHRENS EDWARD D  
3285 67TH AVE SE 98040

Last Updated: 6/15/2023 12:58 PM Jimi

Created: 04-04-23



Seaborn Pile Driving  
1080 W Ewing St  
Seattle, WA 98119

Office: 206-236-1700 ext. 3  
www.seabornpiledriving.com



9706 4th Ave NE  
Suite 300  
Seattle, WA 98115

P: 206.523.0024  
www.dcgengr.com



DRAWN BY: IK  
DESIGNED BY: JS  
CHECKED BY: DT

Scope of Work: We propose to repair the existing dock and swim step with grated decking material, and repair (11) existing piles.

SHEET  
S1.02

**LEGEND**

- ⊕ (11) EXISTING PILES - SLEEVE REPAIR
- (16) EXISTING PILES - NO WORK TO BE DONE/CROWN CONNECTION TO DOCK
- (2) NEW PIN PILES - TO BE INSTALLED

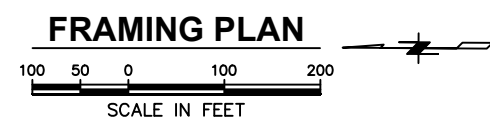
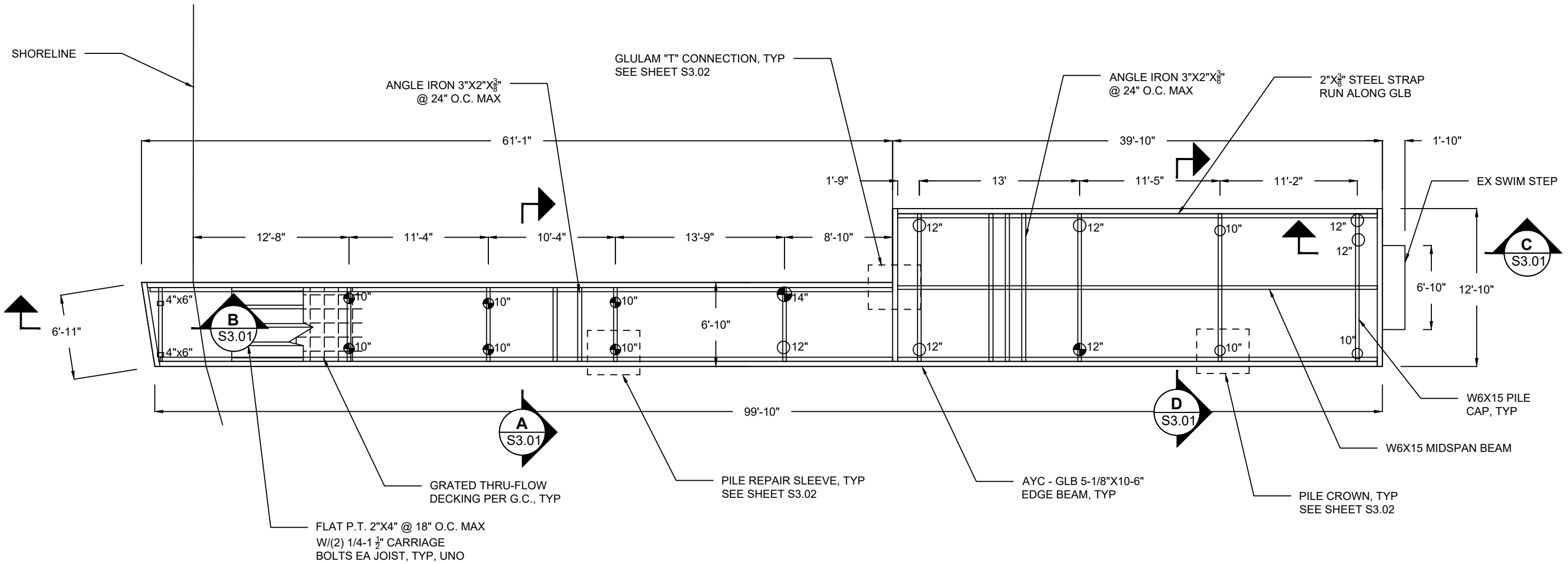

County: King County  
 Location: Lake Washington  
 Applicant: McMillan Residence  
 3425 67th Ave SE  
 Mercer Island, WA 98040  
 Datum: CORPS OF ENGINEERS 1919  
 SW Quarter Of Section 12, Township 24, Range 04  
 Adjacent Owners:  
 AHRENS EDWARD D  
 3285 67TH AVE SE 98040  
 BEHAR RONALD+JAY-CO-TTEES  
 3425 67TH AVE SE 98040  
 Created: 04-04-23  
 Last Updated: 6/15/2023 12:58 PM Jimi



Seaborn Pile Driving  
 1080 W Ewing St  
 Seattle, WA 98119  
 Office: 206-236-1700 ext. 3  
 www.seabornpiledriving.com



9706 4th Ave NE  
 Suite 300  
 Seattle, WA 98115  
 P: 206.523.0024  
 www.dcgengr.com



DRAWN BY: IK  
 DESIGNED BY: JS  
 CHECKED BY: DT

Scope of Work: We propose to repair the existing dock and swim step with grated decking material, and repair (11) existing piles.

**SHEET S2.01**

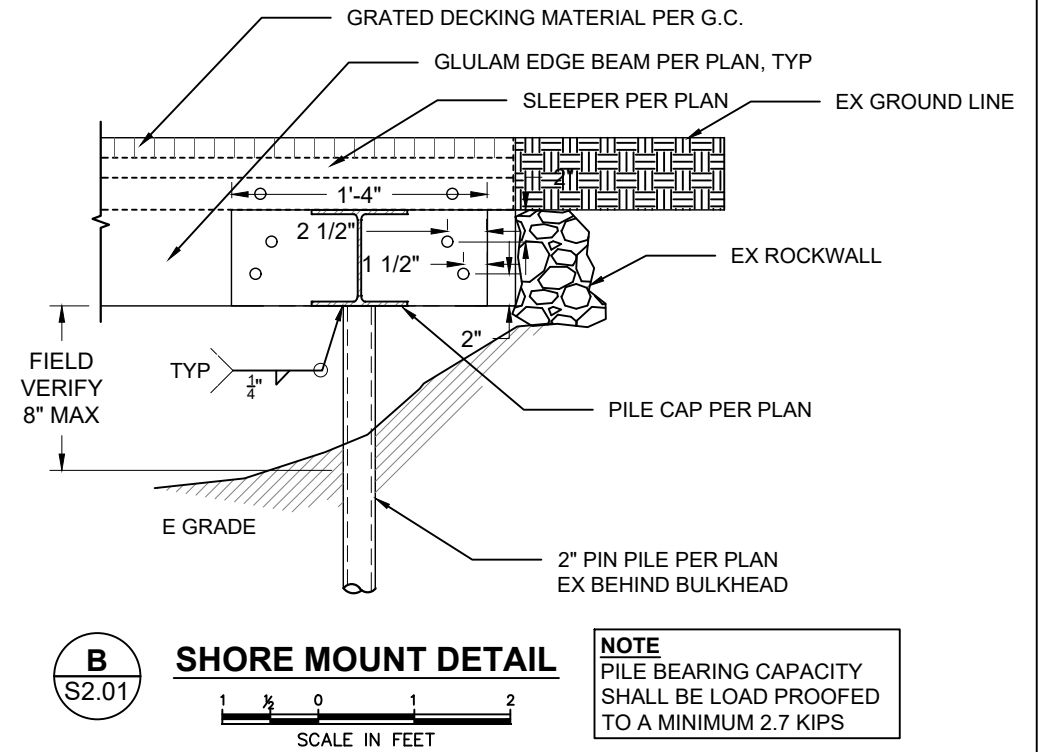
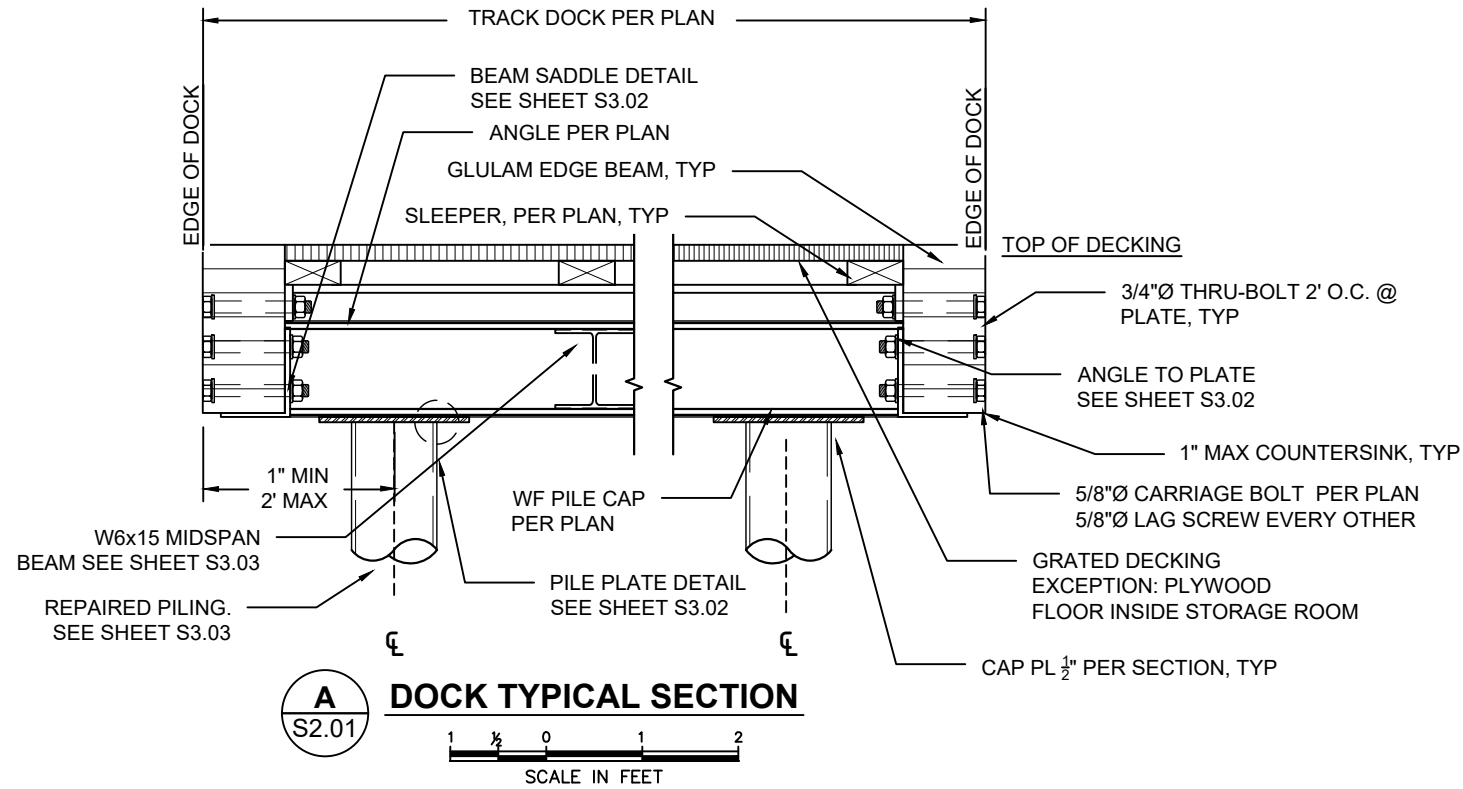

**NOTE**  
PILE BEARING CAPACITY SHALL BE LOAD PROOFED TO A MINIMUM 2.7 KIPS

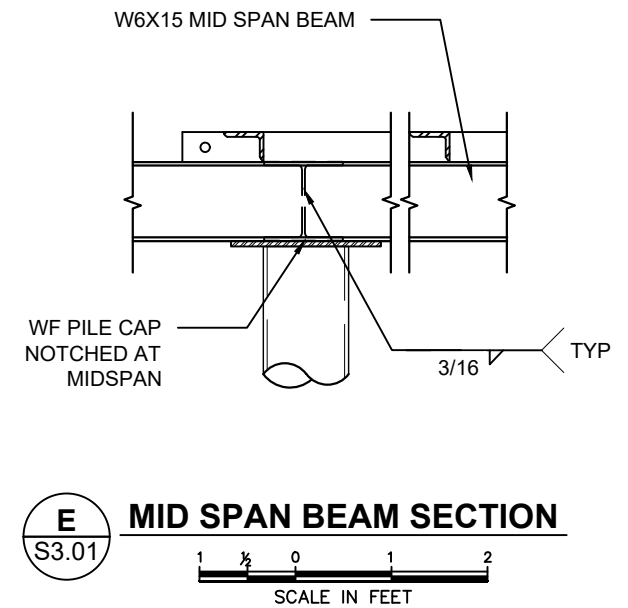
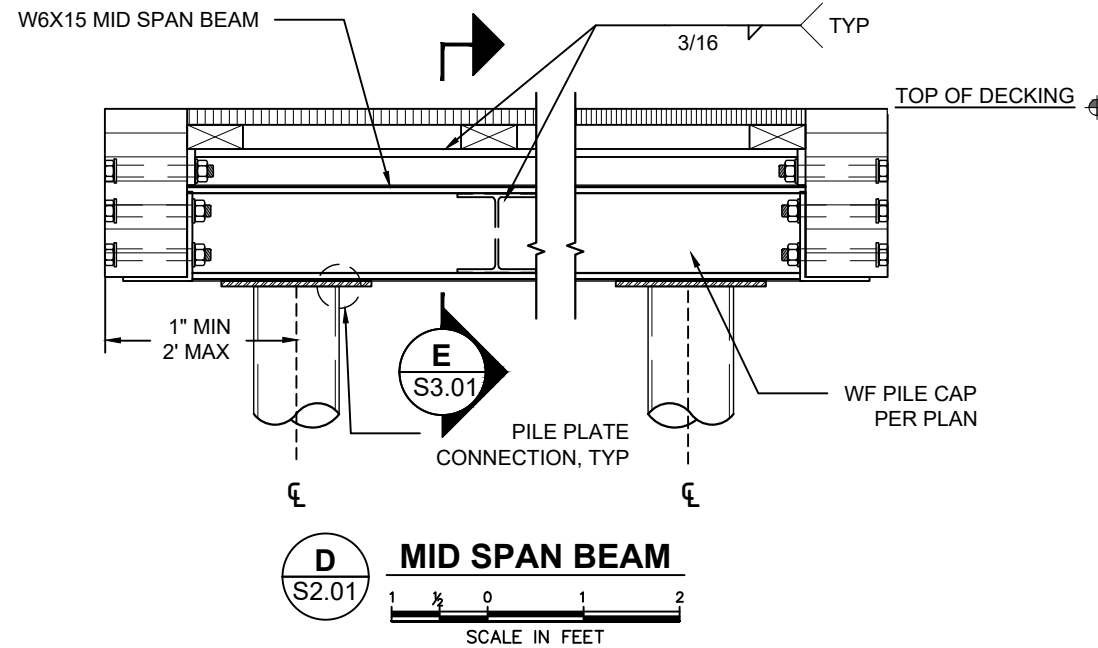
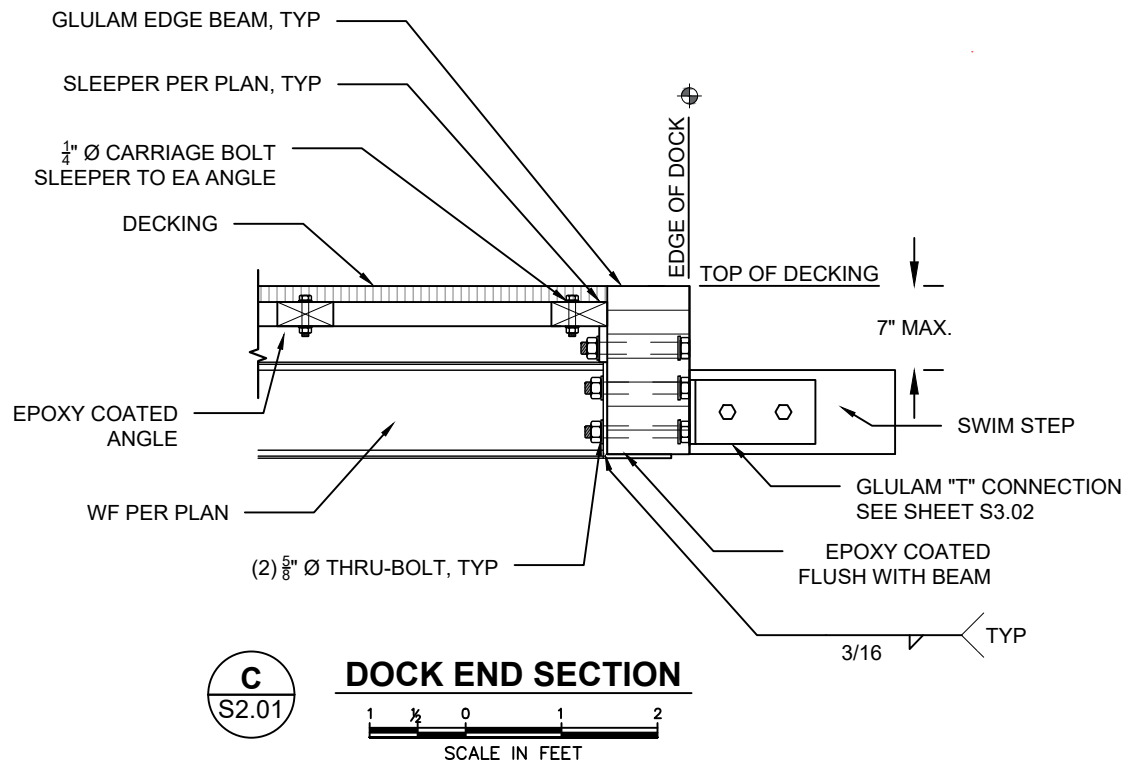

Seaborn Pile Driving  
1080 W Ewing St  
Seattle, WA 98119  
Office: 206-236-1700 ext. 3  
www.seabornpiledriving.com



9706 4th Ave NE  
Suite 300  
Seattle, WA 98115  
P: 206.523.0024  
www.dcgengr.com



DRAWN BY: IK  
DESIGNED BY: JS  
CHECKED BY: DT

Scope of Work: We propose to repair the existing dock and swim step with grated decking material, and repair (11) existing piles.

**SHEET S3.01**

County: King County  
Location: Lake Washington

Applicant: McMillan Residence  
3425 67th Ave SE  
Mercer Island, WA 98040

Datum: CORPS OF ENGINEERS 1919  
SW Quarter Of Section 12, Township 24, Range 04

Adjacent Owners:  
AHRENS EDWARD D  
3285 67TH AVE SE 98040

Last Updated: 6/15/2023 12:58 PM Jimi

Created: 04-04-23

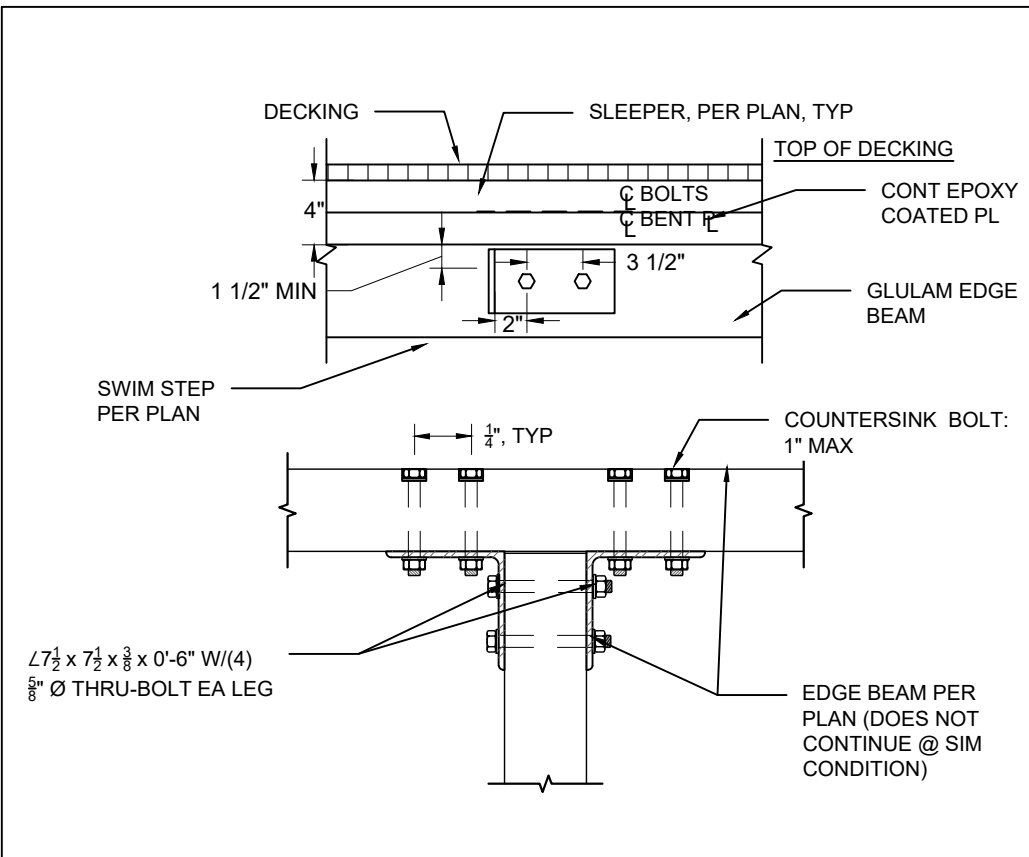

**GLULAM "T" CONNECTION PLAN**

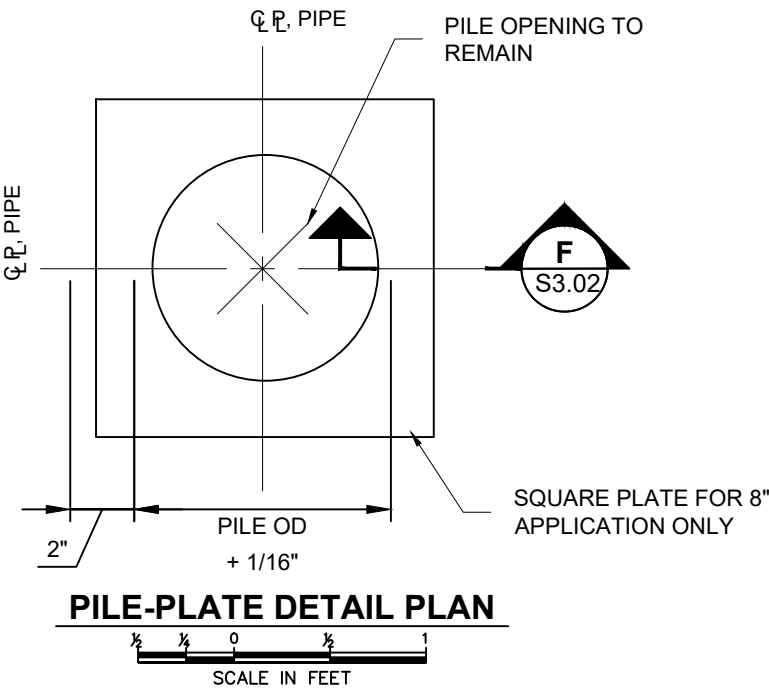

**PILE-PLATE DETAIL PLAN**

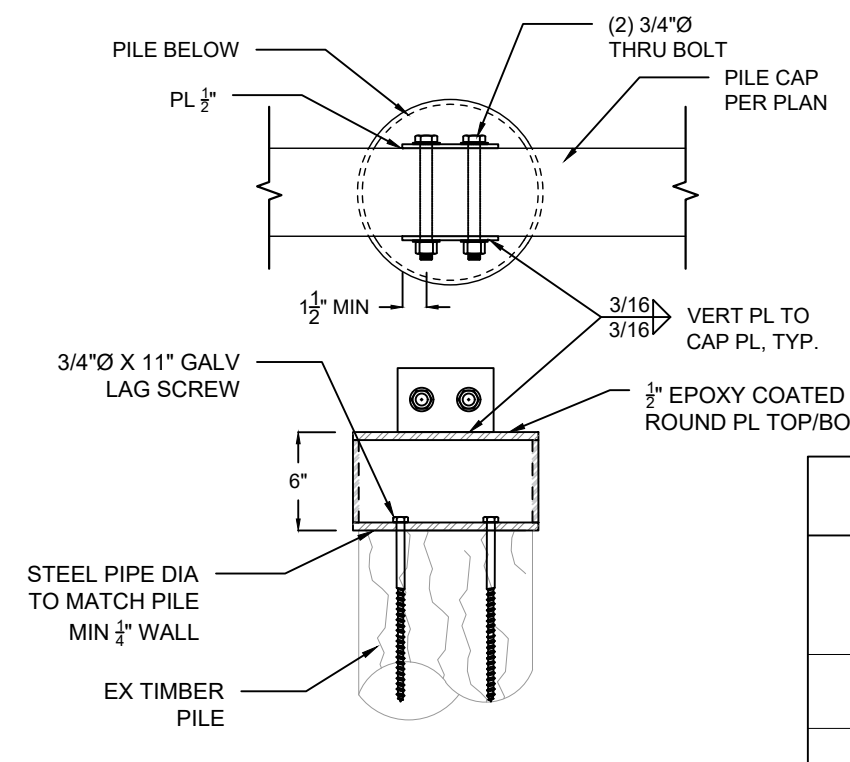

**PILE CROWN**

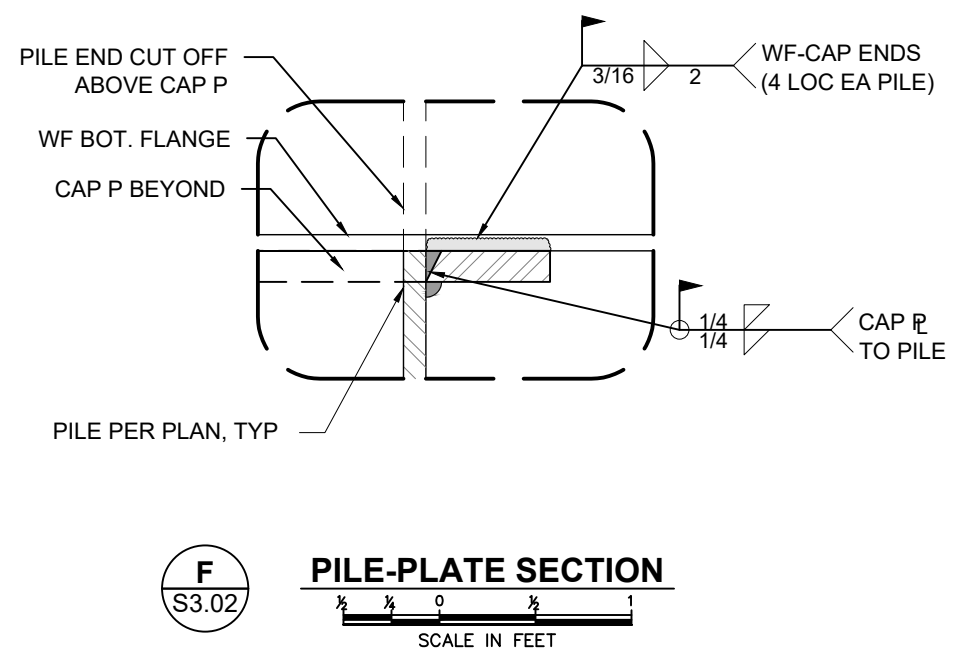

**PILE-PLATE SECTION**

F S3.02

CONTRACTOR TO VERIFY THAT THE PILE FITS SNUGLY IN THE SLEEVE SUCH THAT THERE IS UNIFORM BEARING OF THE PILE AGAINST THE SLEEVE

STEEL SLEEVE TABLE	
PILE Ø	MIN D
8"	27"
10"	30"
12"+	36"

**PILE REPAIR - SLEEVE**

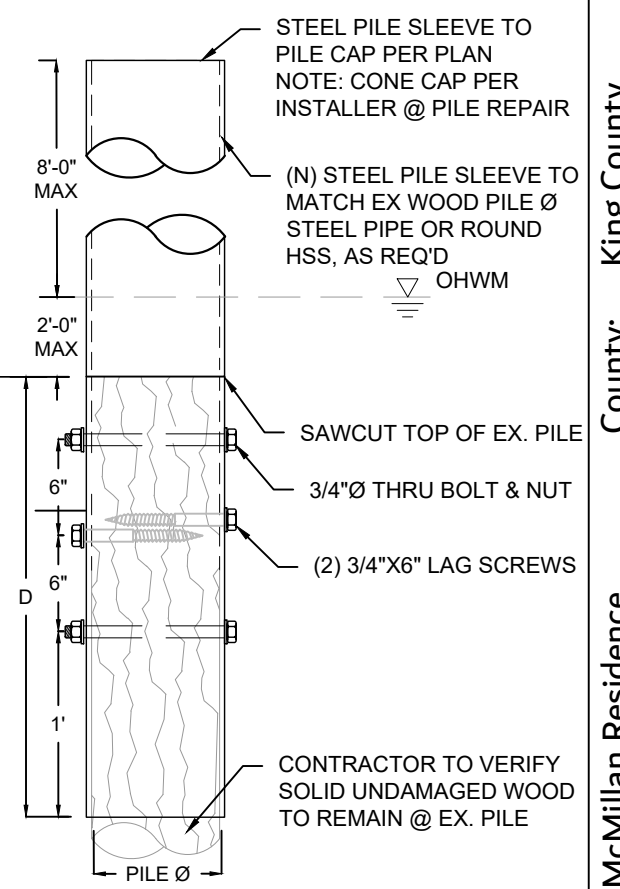

County: King County  
Location: Lake Washington  
Applicant: McMillan Residence  
3425 67th Ave SE  
Mercer Island, WA 98040  
Datum: CORPS OF ENGINEERS 1919  
SW Quarter Of Section 12, Township 24, Range 04  
Adjacent Owners:  
AHRENS EDWARD D  
3285 67TH AVE SE 98040  
BEHAR RONALD+JAY-CO-TTEES  
3428 67TH AVE SE 98040  
Created: 04-04-23  
Last Updated: 6/15/2023 12:58 PM Jimi



Seaborn Pile Driving  
1080 W Ewing St  
Seattle, WA 98119  
Office: 206-236-1700 ext. 3  
www.seabornpiledriving.com



9706 4th Ave NE  
Suite 300  
Seattle, WA 98115  
P: 206.523.0024  
www.dcgengr.com

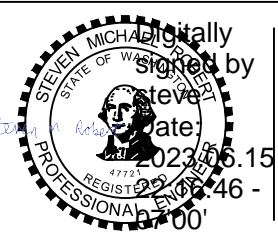

DRAWN BY: IK  
DESIGNED BY: JS  
CHECKED BY: DT

Scope of Work: We propose to repair the existing dock and swim step with grated decking material, and repair (11) existing piles.

**SHEET S3.02**